

SPECIFICATION

Preliminary Specification
 Final Specification

Description **3.5” 320xRGBx240 TFT-LCD Module**
Part Number **P0350QVF1ME00**

Customer	Industrial Product Dept, PDBU Tianma Microelectronics Co., Ltd.		
Signatures	Date	Approved By	Date
_____	_____	Xiaoxing.Ding	_____
_____	_____	Reviewed By	_____
_____	_____	Longping.Deng	_____
_____	_____	Prepared By	_____
_____	_____	Lixian.Xu	2021/12/8
Comments:			

* This cover page is for your Comments and Signatures back to TIANMA.

CONTENTS

1. SUMMARY.....	1
1.1 General Description.....	1
1.2 Features.....	1
2. GENERAL SPECIFICATIONS.....	2
3. INPUT / OUTPUT TERMINALS.....	3
3.1 CN1 Pin assignment (LCD Interface).....	3
4. ABSOLUTE MAXIMUM RATINGS.....	5
4.1 Driving TFT LCD Panel.....	5
5. ELECTRICAL CHARACTERISTICS.....	6
5.1 DC Characteristics for Panel Driving.....	6
5.2 DC Characteristics for Backlight Driving.....	6
5.3 LCD Module Block Diagram.....	7
6. INTERFACE TIMING CHARACTERISTICS.....	8
6.1 24 bit RGB mode Input timing.....	8
6.2 3-Wire SPI Interface Input timing.....	11
6.3 Power On Sequence.....	12
6.4 Power off Sequence.....	12
7. OPTICAL CHARACTERISTICS.....	13
8. RELIABILITY TEST.....	16
9. MECHANICAL DRAWING.....	17
10. PACKING INSTRUCTION.....	18
11. PRECAUTIONS FOR USE OF LCD MODULES.....	19
11.1 Handling Precautions.....	19
11.2 Storage precautions.....	20
11.3 Transportation Precautions.....	20
11.4 Screen saver Precautions.....	20
11.5 Safety Precautions.....	20

1. Summary

1.1 General Description

This is a 3.5 inch a-Si TFT-LCD module with Normal- Black technology. It is composed of a TFT-LCD panel, a driver circuit, and a LED backlight unit.

1.2 Features

- Ultra-wide viewing angle: Super Fine TFT
- Interface: RGB
- Surface treatment:HC

- Acquisition product for UL62368-1/CSA C22.2 No.62368-1-03 (File number: E170632)
- Compliant with the European RoHS Directive (2011/65/EU) and Delegated Directive (2015/863/EU, Amending Annex II of 2011/65/EU)

2. General Specifications

	Feature	Spec	Unit
Display Spec	Size	3.5 inch	
	Resolution	320(RGB)x240	
	Pixel Pitch	0.219x0.219	mm
	TFT Active Area	70.08x52.56	mm
	Technology Type	a-Si	
	Pixel Configuration	R.G.B Vertical Stripe	
	Display Mode	SFT, Normally Black	
	Surface Treatment	HC	
	Viewing Direction	All	
	Gray Scale Inversion Direction	NA	
Mechanical Characteristics	LCM (W x H x D)	76.9x63.9x3.15	mm
	Weight	Typ:31	g
Optical Characteristics	Luminance	Min:280 Typ:350	cd/m ²
	Contrast Ratio	Min:600 Typ:800	
	NTSC	Min:55 Typ:60	%
	Viewing Angle	Typ:88/88/88/88(SFT)	degree
Electrical Characteristics	Interface	RGB 24bit+SPI or RGB24bit	
	Color Depth	16.7 Million	color
	Power Consumption	LCD:70; Backlight:360	mW

Table 2.1 General TFT Specifications

Note 1: Viewing direction for best image quality is different from TFT definition, there is a 180 degree shift.

Note 2: Requirements on Environmental Protection: Q/S0002

Note 3: LCM weight tolerance: $\pm 5\%$

Note 4: The GND of the module FPC must be connected with the system board, and the bezel must be connected to the system GND.

3. Input / Output Terminals

3.1 CN1 Pin assignment (LCD Interface)

Connector Information	
Matching connector	Kyocera elco:6240 serials

Table 3.1.1 Connector information

No	Symbol	I/O/P	Description	Remarks
1	LED_Cathode	P	LED_Cathode	
2	LED_Cathode	P	LED_Cathode	
3	LED_Anode	P	LED_Anode	
4	LED_Anode	P	LED_Anode	
5	NC	-	No Connect	
6	NC	-	No Connect	
7	NC	-	No Connect	
8	RESET	I	Reset	
9	SPENA	I	Serial port data enable signal	
10	SPCK	I	SPI Serial Clock Input	
11	SPDA	I/O	SPI Serial Data Input and output	
12	D00	I	Blue data 0 (LSB)	
13	D01	I	Blue data 1	
14	D02	I	Blue data 2	
15	D03	I	Blue data 3	
16	D04	I	Blue data 4	
17	D05	I	Blue data 5	
18	D06	I	Blue data 6	
19	D07	I	Blue data 7 (MSB)	
20	D08	I	Green data 0 (LSB)	
21	D09	I	Green data 1	
22	D10	I	Green data 2	
23	D11	I	Green data 3	
24	D12	I	Green data 4	
25	D13	I	Green data 5	
26	D14	I	Green data 6	
27	D15	I	Green data 7 (MSB)	
28	D16	I	Red data 0 (LSB)	
29	D17	I	Red data 1	
30	D18	I	Red data 2	
31	D19	I	Red data 3	
32	D20	I	Red data 4	

Industrial Display Module

33	D21	I	Red data 5	
34	D22	I	Red data 6	
35	D23	I	Red data 7 (MSB)	
36	HSYNC	I	Horizontal Synchronous Signal ,Negative polarity	
37	VSYNC	I	Vertical Synchronous Signal, Negative polarity	
38	DOTCLK	I	Data Clock, Latch the data at falling edge.	
39	NC	-	No Connect	
40	NC	-	No Connect	
41	VDD	P	power supply (3.3V)	
42	VDD	P	power supply (3.3V)	
43	NC	-	No Connect	
44	NC	-	No Connect	
45	NC	-	No Connect	
46	NC	-	No Connect	
47	NC(AUTODL)	-	No Connect (Auto-refresh function control pin.)	
48	NC(DISP)	-	No Connect (Sets the display mode.)	
49	NC(ENPROG)	-	No Connect (OTP program control pin.)	
50	NC	-	No Connect	
51	NC	-	No Connect	
52	DEN	I	Data input enable. Display access is enabled when DE is "H".	
53	GND	P	Ground	
54	GND	P	Ground	

Table 3.1.2 Pin Assignment for LCD Interface

Note1: I/O definition: I---Input, O---Output, P---Power/Ground, N---No connection

4. Absolute Maximum Ratings

4.1 Driving TFT LCD Panel

GND=0V

Item	Symbol	Min	Max	Unit	Remark
Power Supply Voltage	VDD	-0.3	4.0	V	
Logic Input Signal Voltage	V _{IN}	-0.3	VDD+0.3	V	Note1
Back Light Forward Current	I _{LED}	--	20	mA	For each LED
Operating Temperature	T _{OPR}	-20	70	°C	
Storage Temperature	T _{STG}	-30	80	°C	
Relative Humidity (Note1)	RH	--	≤95	%	Ta≤40°C
		--	≤85	%	40°C < Ta ≤ 50°C
		--	≤55	%	50°C < Ta ≤ 60°C
		--	≤36	%	60°C < Ta ≤ 70°C
		--	≤24	%	70°C < Ta ≤ 80°C
Absolute Humidity	AH	--	≤70	g/m ³	Ta > 70°C

Table 4.1 Absolute Maximum Ratings

Note1: Input voltage include :RESET, SPENA, SPCK, SPDA, DOTCLK, HSYNC, VSYNC, DEN , D00~D23

Note2: Ta means the ambient temperature.

It is necessary to limit the relative humidity to the specified temperature range.
Condensation on the module is not allowed.

5. Electrical Characteristics

5.1 DC Characteristics for Panel Driving

GND=0V, Ta=25°C

Item	Symbol	Min	Typ	Max	Unit	Remark
Power Supply Voltage	VDD	3.2	3.3	3.4	V	
Input Signal Voltage	Low Level	VIL	GND	--	0.3*VDD	V
	High Level	VIH	0.7*VDD	--	VDD	V
(Panel+ LSI) Power Consumption	White Mode (60Hz)	--	70	--	mW	
	Standby Mode	--	0.5	--	mW	

Table 5.1.1 Operating Voltages

5.2 DC Characteristics for Backlight Driving

Ta=25°C

Item	Symbol	Min	Typ	Max	Unit	Remark
Forward Current	I _F	--	20	--	mA	
Forward Voltage	V _F	--	18	--	V	
Power Consumption	W _{BL}	--	360	--	mW	
Operating Life Time	--	--	30000	--	Hrs	

Table 5.2.1 LED Backlight Characteristics

Note 1: The figure below shows the connection of backlight LED.



Note 2: Each LED : I=20 mA, V =3V

Note 3: I_F is defined for one channel LED.

Optical performance should be evaluated at Ta=25°C only.

If LED is driven by high current, high ambient temperature & humidity condition, the life time of LED will be reduced.

Operating life means brightness goes down to 50% initial brightness. Typical operating life time is estimated data.

5.3 LCD Module Block Diagram

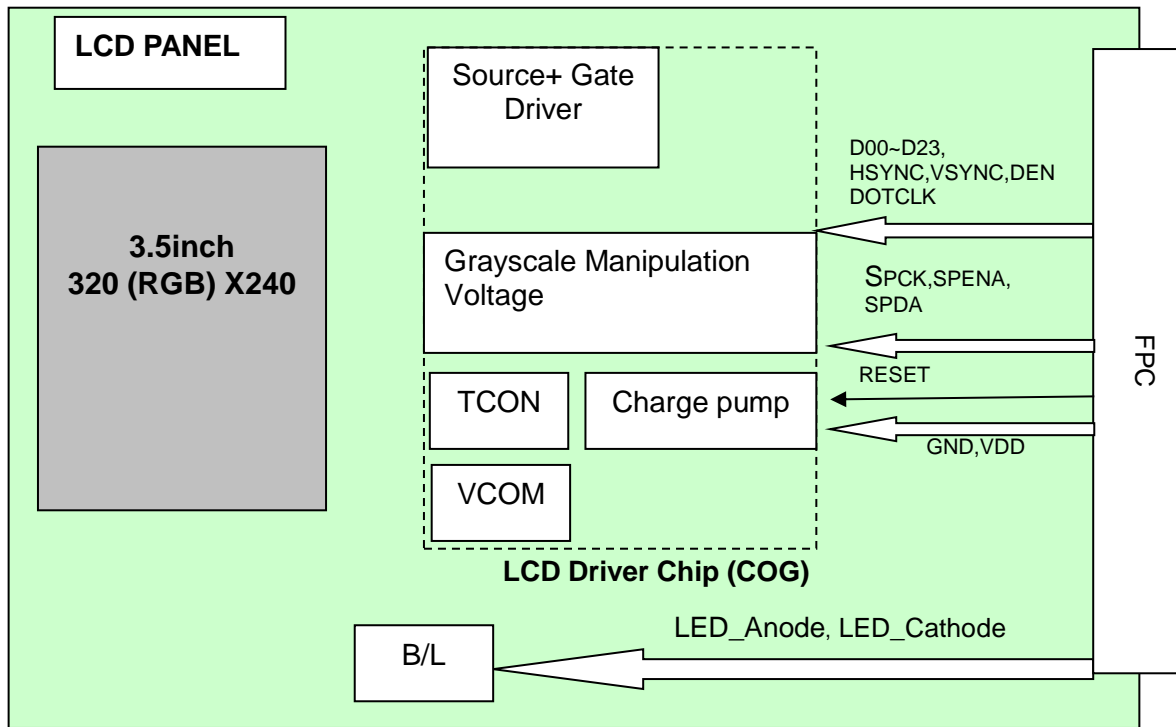

Figure 5.5.1 LCD Module Block Diagram

6. Interface Timing Characteristics

6.1 24 bit RGB mode Input timing

6.1.1 RGB interface characteristics

(VDD=3.3V, GND= 0V, Ta=25°C)

Parameter	Symbol	Min	Typ	Max	Unit	Condition
DOTCLK Pulse Duty	T_{clk}	40	50	60	%	
HSYNC Width	T_{hw}	2	--	--	DCLK	
VSYNC Setup Time	T_{vst}	12	--	--	ns	
VSYNC Hold Time	T_{vhd}	12	--	--	ns	
HSYNC Setup Time	T_{hst}	12	--	--	ns	
HSYNC Hold Time	T_{hhd}	12	--	--	ns	
Data Setup Time	T_{dsu}	12	--	--	ns	
Data Hold Time	T_{dhd}	12	--	--	ns	
DEN Setup Time	T_{dest}	12	--	--	ns	
DEN Hold Time	T_{dehd}	12	--	--	ns	

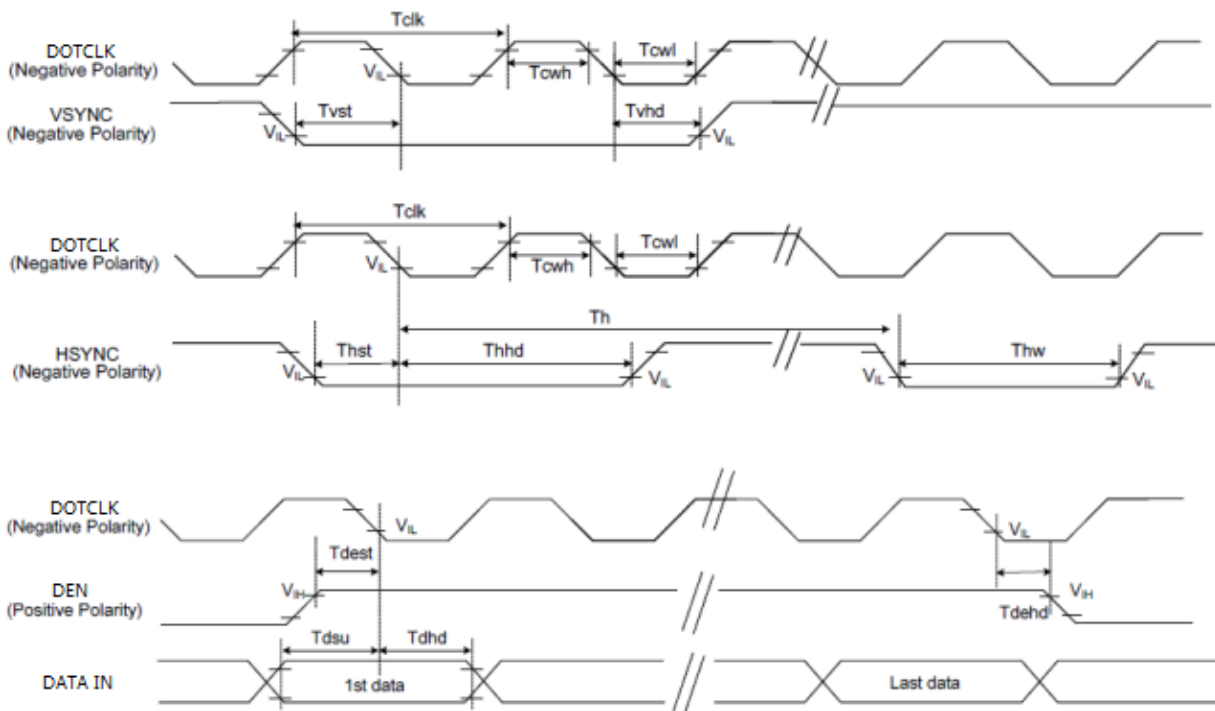

6.1.2 System Bus Timing for RGB Interface

(VDD=3.3V, GND= 0V, Ta=25°C)

Parameter		Symbol	Min	Typ	Max	Unit	Condition
DOTCLK Frequency		Fclk	5	6	8	MHz	
DOTCLK Period		Tclk	125	167	200	ns	
HSYNC	Period Time	Th	325	371	438	DOTCLK	
	Display Period	Thdisp	--	320	--	DOTCLK	
	Back Porch	Thbp	3	43	43	DOTCLK	
	Front Porch	Thfp	2	8	75	DOTCLK	
	Pulse Width	Thw	2	4	43	DOTCLK	
VSYNC	Period Time	Tv	244	260	289	HSYNC	
	Display Period	Tvdisp	--	240	--	HSYNC	
	Back Porch	Tvbp	2	12	12	HSYNC	
	Front Porch	Tvfp	2	8	37	HSYNC	
	Pulse Width	Tvw	2	4	12	HSYNC	

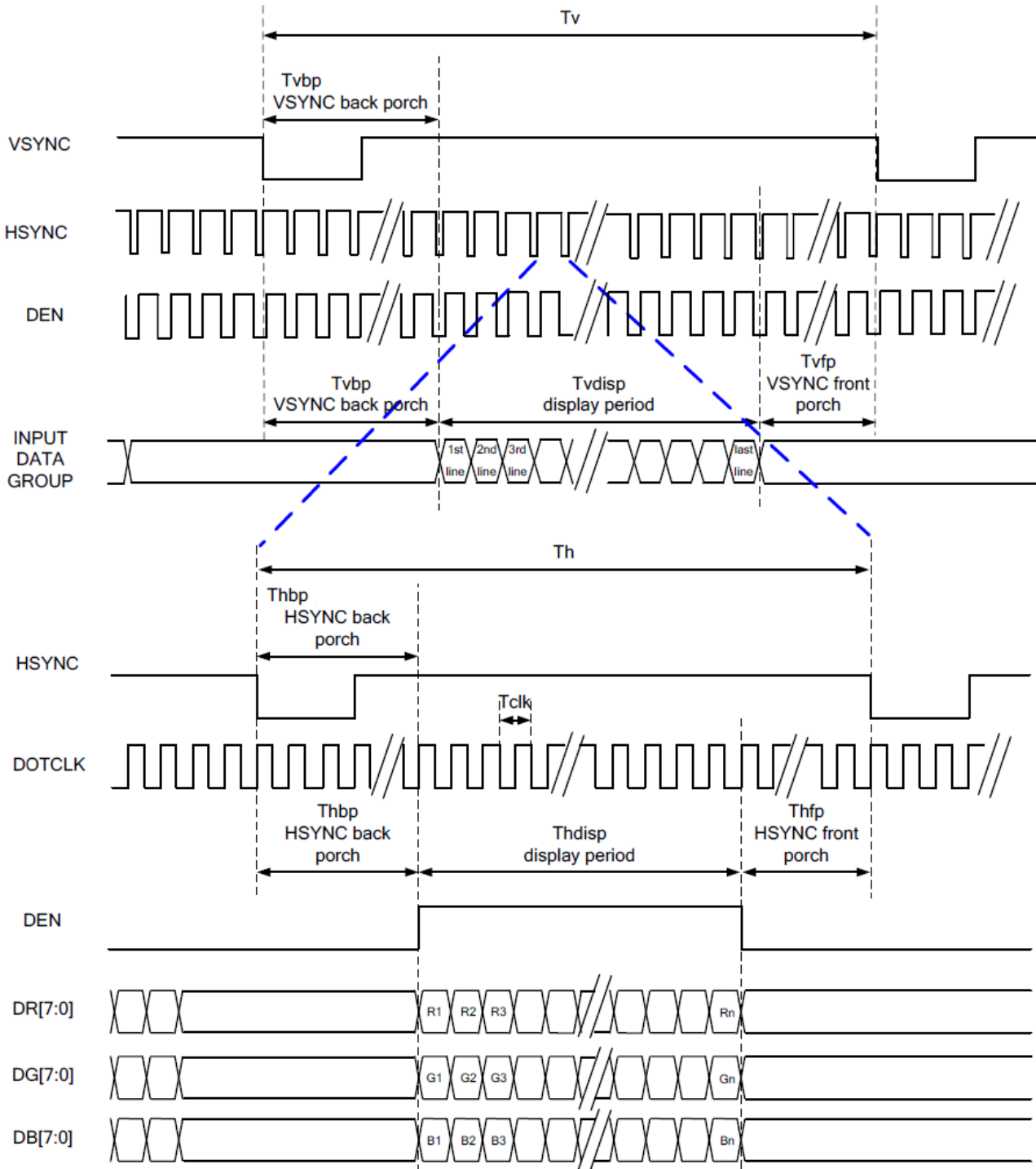

6.2 3-Wire SPI Interface Input timing

6.2.1 3-Wire SPI Interface characteristics

Parameter	Symbol	Min	Typ	Max	Unit	Remark
SPENA Input Setup Time	T_{s0}	50	--	--	ns	
Serial Data Input Setup Time	T_{s1}	50	--	--	ns	
SPENA Input Hold Time	T_{h0}	50	--	--	ns	
Serial Data Input Hold Time	T_{h1}	50	--	--	ns	
SPCK Write Pulse High Width	T_{wh1}	50	--	--	ns	
SPCK Write Pulse Low Width	T_{wl1}	50	--	--	ns	
SPCK Read Pulse High Width	T_{rh1}	300	--	--	ns	
SPCK Read Pulse Low Width	T_{rl1}	300	--	--	ns	
SPENA Pulse High Width	T_{w2}	400	--	--	ns	

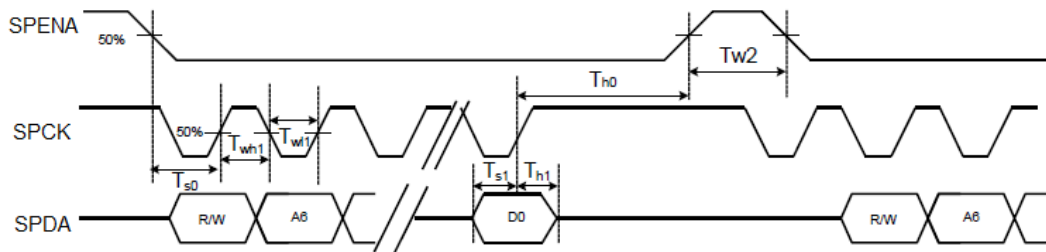

6.2.2 3-Wire SPI Interface protocol

R/W: Read/Write mode control bit.
 R/W=1: Read mode
 R/W=0: Write mode

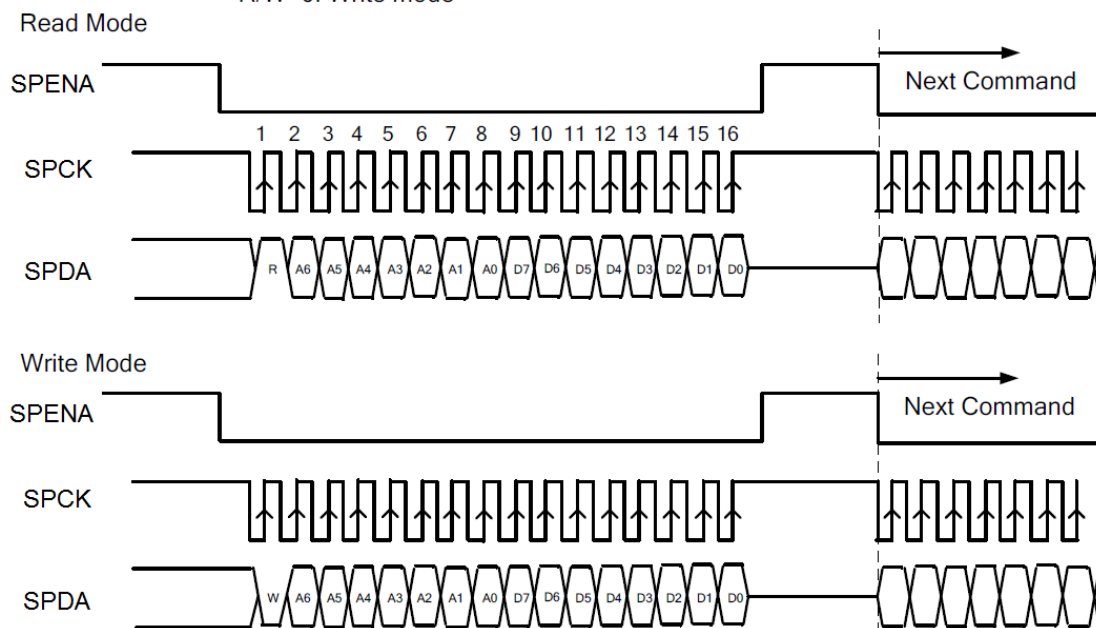

6.3 Power On Sequence

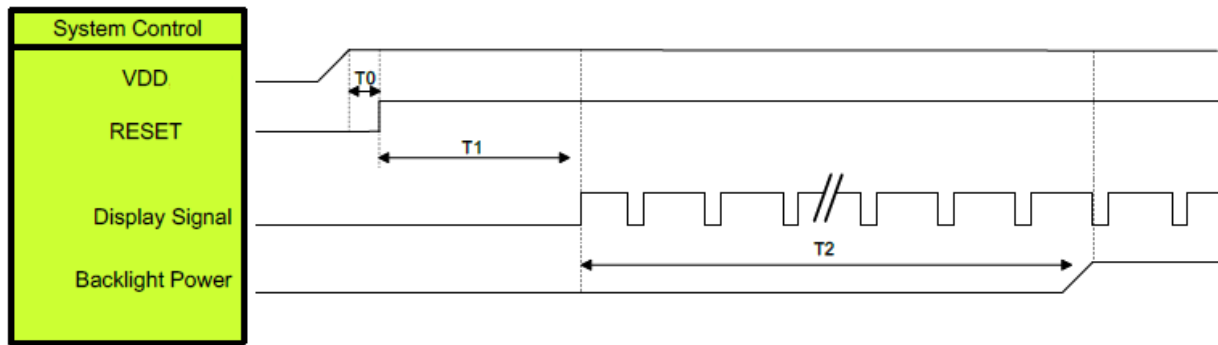

Symbol	Description	Min. Time	Unit
T0	System power stability to RESET signal	0	ms
T1	RESET= "High" to Display Signal output	10	ms
T2	Display Signal output to Backlight Power on	250	ms

Note: Display signal: DOTCLK;VSYNC;HSYNC;DEN;D[00~23]

6.4 Power off Sequence

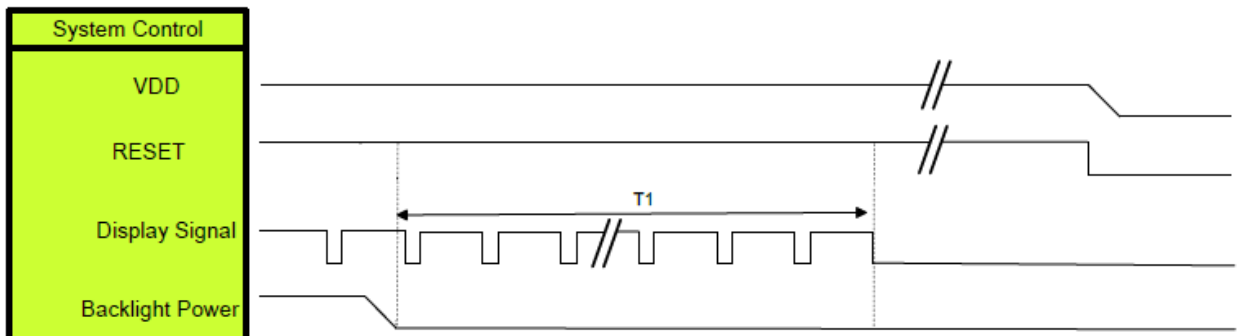

Symbol	Description	Min. Time	Unit
T1	Backlight Power off to IC internal voltage discharge complete	80	ms

Note: Display signal: DOTCLK;VSYNC;HSYNC;DEN;D[00~23]

7. Optical Characteristics

Ta=25°C

Item	Symbol	Condition	Min	Typ.	Max.	Unit	Remark
View Angles	θT	$CR \geq 10$	70	88	--	Degree	Note 2 Note 3
	θB		70	88	--		
	θL		70	88	--		
	θR		70	88	--		
Contrast Ratio	CR	$\theta=0^\circ$	600	800	--		Note3
Response Time	T_{ON}	25°C	--	25	35	ms	Note4
	T_{OFF}						
Chromaticity	White	x	0.251	0.301	0.351		Note 1 Note 5
		y	0.265	0.315	0.365		
	Red	x	0.575	0.625	0.675		
		y	0.304	0.354	0.404		
	Green	x	0.294	0.344	0.394		
		y	0.536	0.586	0.636		
	Blue	x	0.098	0.148	0.198		
		y	0.027	0.077	0.127		
Uniformity	U		75	80	--	%	Note6
NTSC			55	60	--	%	Note 5
Luminance	L		280	350	--	cd/m ²	Note7

Table 7.1 Optical Parameters

Test Conditions:

1. $V_F = 18\text{ V}$, $I_F = 20\text{ mA}$ (LED current), the ambient temperature is 25°C.
2. The test systems refer to Note1 and Note2.

Note1: Definition of optical measurement system.

The optical characteristics should be measured in dark room. After 5 Minutes operation, the optical characteristics are measured at the center point of the LCD screen.

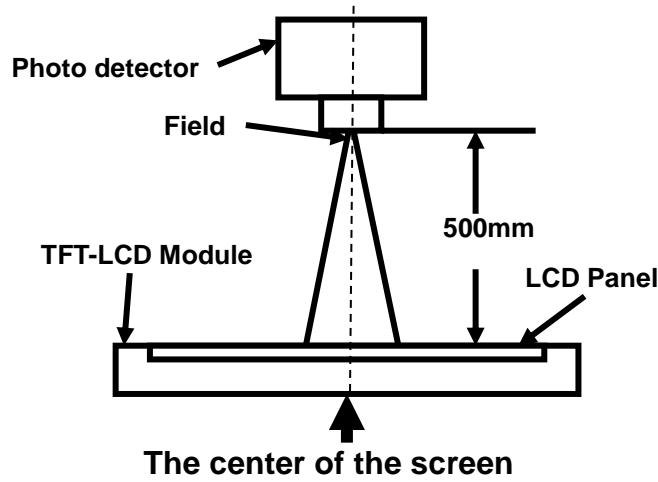

Fig1.Measurement Set Up

Note2: Definition of viewing angle range and measurement system. Viewing angle is measured at the center point of the LCD .

Viewing angle is measured at the center point of the LCD by EZ-Contrast.

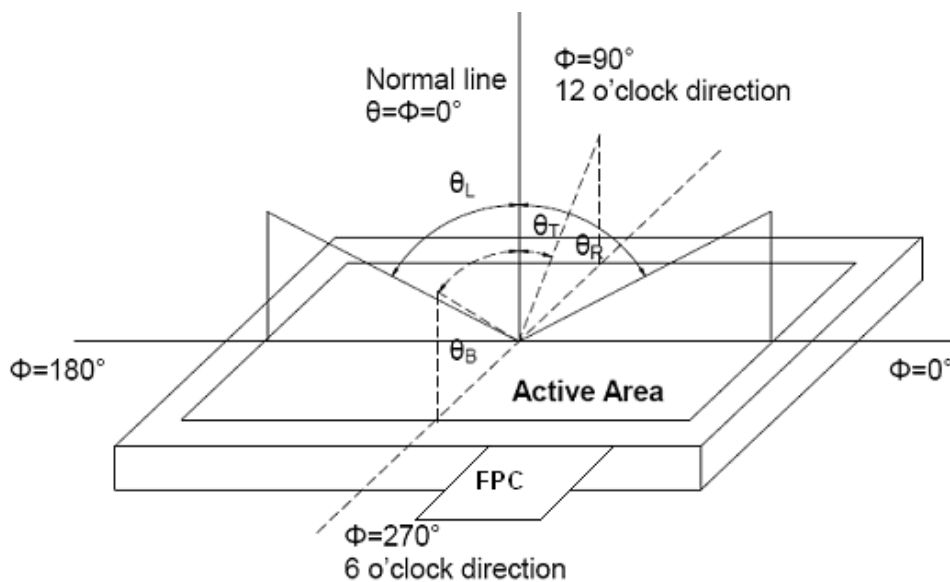

Fig2. Definition viewing angle

Note3: Definition of contrast ratio

$$\text{Contrast ratio (CR)} = \frac{\text{Luminance measured when LCD is on the "White" state}}{\text{Luminance measured when LCD is on the "Black" state}}$$

Note4: Definition of Response time

For SFT LCM, the response time is defined as the LCD optical switching time interval between “White” state and “Black” state. Rise time (T_r) is the time between photo detector output intensity changed from 10% to 90%. And fall time (T_f) is the time between photo detector output intensity changed from 90% to 10%.

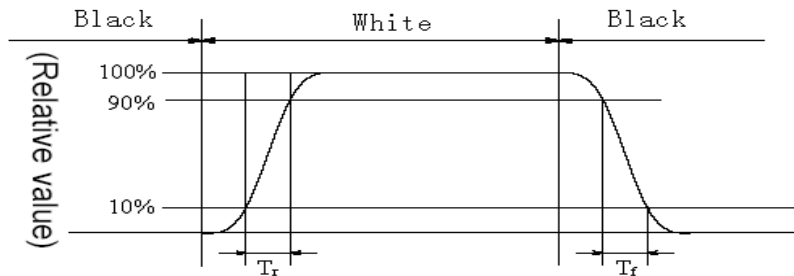

Fig4.Response Time Testing(SFT)

Note5: Definition of color chromaticity (CIE1931)

Color coordinates measured at center point of LCD.

Note6: Definition of Luminance Uniformity

Active area is divided into 9 measuring areas (Refer Fig.5). Every measuring point is placed at the center of each measuring area.

$$\text{Luminance Uniformity (U)} = L_{\min} / L_{\max}$$

L_{\max} : The measured Maximum luminance of all measurement position.

L_{\min} : The measured Minimum luminance of all measurement position.

L-----Active area length; W----- Active area width

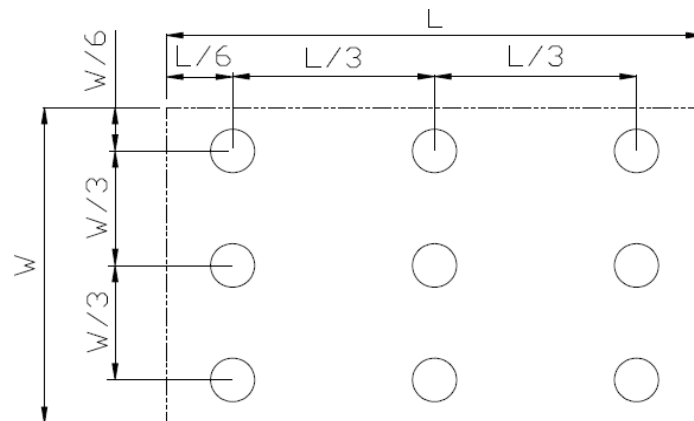

Fig5. Luminance Uniformity Measurement Locations(9 points)

Note7: Definition of Luminance:

Measure the luminance of white state at center point.

8. Reliability Test

No	Test Item	Condition	Remarks
1	High Temperature Operation	+70℃ , 240H	IEC60068-2-1:2007 GB2423.2-2008
2	Low Temperature Operation	-20℃ , 240H	IEC60068-2-1:2007 GB2423.1-2008
3	High Temperature Storage	+80℃ , 240H	IEC60068-2-1:2007 GB2423.2-2008
4	Low Temperature Storage	-30℃ , 240H	IEC60068-2-1:2007 GB2423.1-2008
5	Storage at High Temperature and Humidity(non-operation)	+60℃ , 90%RH , 240H	IEC60068-2-78 :2001 GB/T2423.3—2006
6	Thermal Shock (non-operation)	-30℃ , 30min~80℃ , 30min , change time : 5min , 100cycle	Start with cold temperature, End with high temperature, IEC60068-2-14:1984,GB2423.22-2002
7	Electro Static Discharge (Operation)	C=150pF , R=330Ω , 5point/panel Air : ±8kv , 5times ; Contact : ±4kv , 5times ; (Environment : 15℃~35℃ , 30%~60% , 86Kpa~106Kpa)	IEC61000-4-2:2001 GB/T17626.2-2006
8	Vibration (Non-operation)	Frequency range : 10~55Hz Stroke : 1.5mm Sweep : 10Hz~55Hz~10Hz 2h for x,y,z (total 6h)	IEC60068-2-6:1982 GB/T2423.10-2008
9	Shock (Non-operation)	Half Sine Wave 60G ,6ms,±X,±Y,±Z 3times for each direction	GB/T 4857.23-2012
10	Package Drop Test	Height: TBD cm, 1 corner, 3 edges, 6 surfaces	GB/T 4857.5-1992

Table 8.1 RA test condition

Note1: Temperature is the ambient temperature of sample

Note2: Before cosmetic and function test, the product must have enough recovery time, at least 2 hours at room temperature.

Note3: In the standard condition, there shall be no practical problem that may affect the display function. After the reliability test, the product's function only be guaranteed, but not for all of the cosmetic specification.

9. Mechanical Drawing

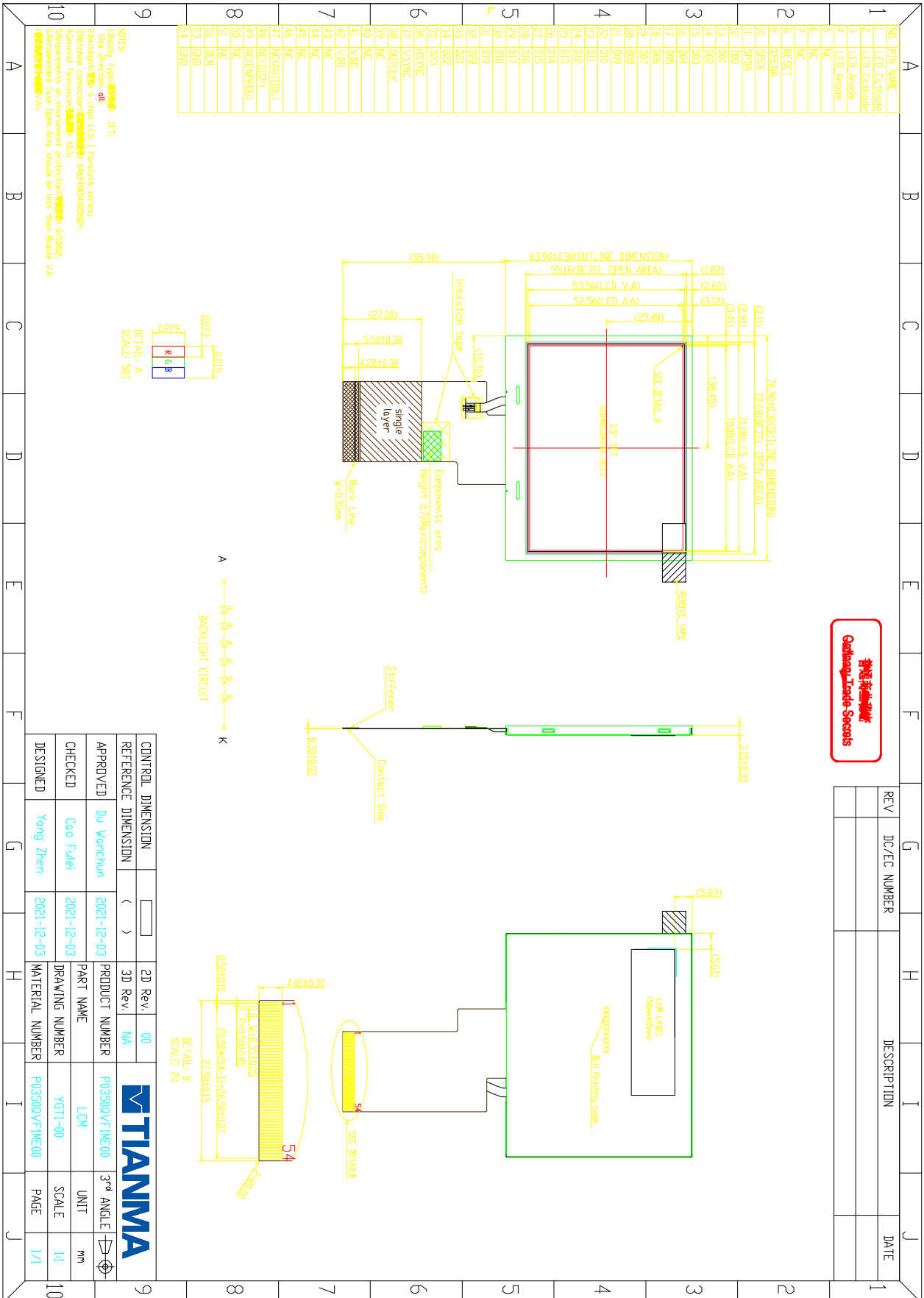

Trade Secrets

10. Packing Instruction

No	Item	Model (Material)	Dimensions (mm)	Unit Weight(Kg)	Q'ty	Remark
1	LCM module	P0350QVF1ME00	76.90×63.90×3.15	0.031	252	
2	Dust-Proof Bag	PE	235×150×0.05mm	0.03	1	
3	Tray	PET	485×330×13.8	0.16	24	
4	Carton	Corrugated Paper	544×365×250	0.76	1	
5	BOX	Corrugated Paper	520×345×74	0.35	3	
6	Label	Paper	100*52	0.001	1	
7	Total weight	13.50±5%Kg				

Total LCM quantity in Carton: quantity per tray 12 × 21 tray = 252

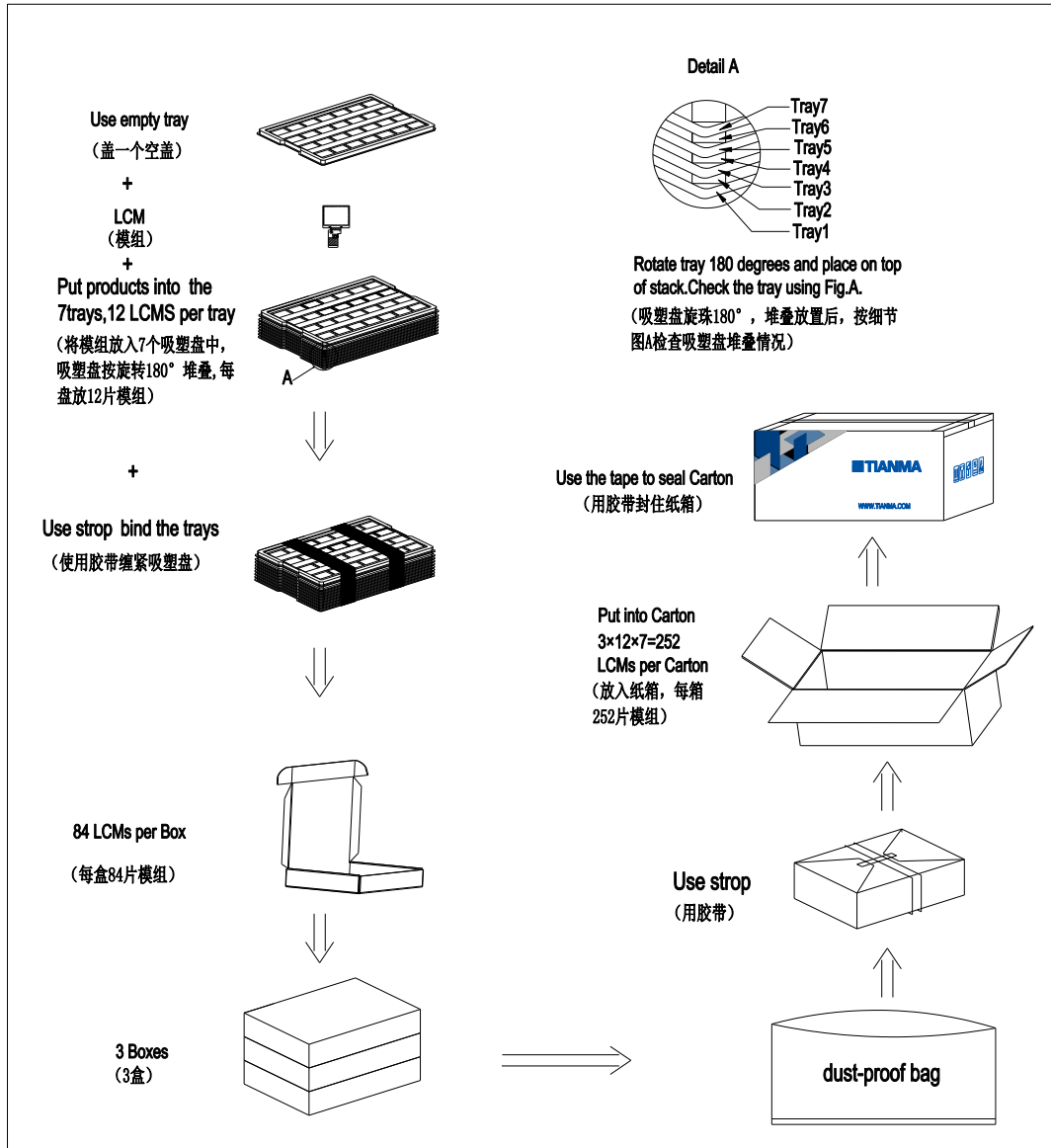

Stacking number of cartons is 2*3 each layer , altogether 5 layers.

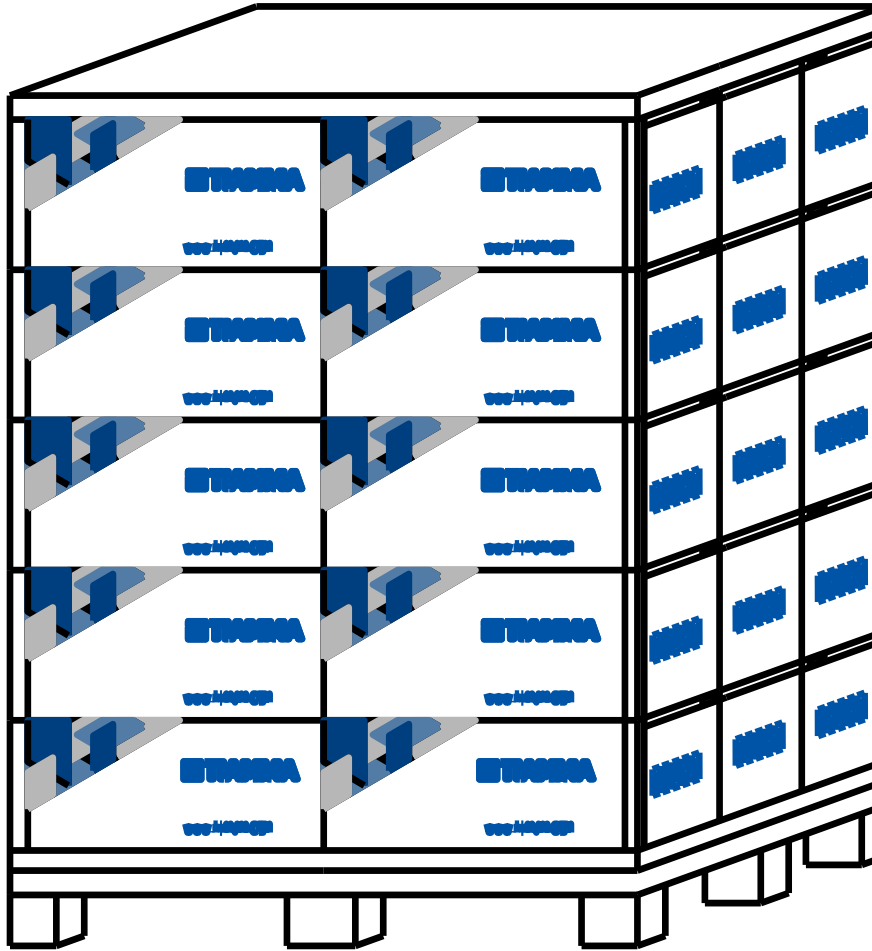

11. Precautions for Use of LCD Modules

11.1 Handling Precautions

- (1) The display panel is made of glass. Do not subject it to mechanical shock by dropping it, etc.
- (2) If the display panel is damaged and the liquid crystal fluid inside it leaks out be sure not to get any in your mouth. If the fluid comes into contact with your skin or clothes promptly wash it off using soap and water.

- (3) Do not apply excessive force to the display surface or the bezel since this may cause the color tone to vary.
- (4) The polarizer covering the display surface of the LCD module is soft and easily scratched. Handle the polarizer carefully.
- (5) If the display surface is contaminated, breathe on the surface and gently wipe it with a soft dry cloth. If it is still not completely clear use a moist cloth with one of the following solvents:
 - Isopropyl alcohol
 - Ethyl alcoholSolvents other than those mentioned above may damage the polarizer. Specifically, do not use the following:
 - Water
 - Ketone
 - Aromatic solvents
- (6) Do not disassemble the LCD Module.
- (7) If powered off, do not apply the input signals.
- (8) To prevent destruction of the module by static electricity, be careful to maintain an optimum work environment.
- (9) Be sure to ground your body when handling the LCD Modules.
- (10) Tools used for assembly, must be properly grounded.
- (11) To reduce the amount of static electricity generated, do not conduct assembly or other work under very low humidity conditions.
- (12) The LCD Module is covered with a film to protect the display surface, remove film slowly under the ionizer.

11.2 Storage precautions

- (1) When storing the LCD modules avoid exposure to direct sunlight or to the light of fluorescent lamps.
- (2) The LCD modules should be stored within the rated storage temperature range. The recommend condition is: Temperature: 0 ~ 35 °C at normal humidity.
- (3) The LCD modules should be stored in a room without acid, alkali or other harmful gas.

11.3 Transportation Precautions

The LCD modules should not be dropped or subject to violent mechanical shock during transportation. Also they should avoid excessive pressure, water, high humidity and direct sunlight.

11.4 Screen saver Precautions

Not display the fixed pattern for a long time. Use a screen saver, if the fixed pattern is displayed on the screen

11.5 Safety Precautions

- (1) When you waste damaged or unnecessary LCDs, it is recommended to crush LCDs into pieces and wash them off with solvents such as acetone and ethanol, which should later be burned
- (2) Be sure to turn off the power supply when inserting or disconnecting the LED backlight cable.
- (3) LED driver should be designed carefully to limit or stop its function when over current is detected on the LED.