

MODEL NO : TM022HDHT11**MODEL VERSION: 00****SPEC VERSION : Ver 1.1****ISSUED DATE: 2015-12-03**

- Preliminary Specification**
- Final Product Specification**

Customer : _____

Approved by	Notes

TIANMA Confirmed :

Prepared by	Checked by	Approved by
Ke Ke	Fan Jiang	Feng Qin

This technical specification is subjected to change without notice

Table of Contents

Table of Contents.....	2
Record of Revision.....	3
1.General Specifications.....	4
2.Input/Output Terminals.....	5
3.Absolute Maximum Ratings.....	6
4. Electrical Characteristics.....	6
5. Timing Chart.....	8
6 Optical Characteristics.....	12
7. Environmental / Reliability Test.....	17
8. Mechanical Drawing.....	18
9. Packing Drawing.....	19
10. Precautions for Use of LCD Modules.....	20

1. General Specifications

	Feature	Spec
Display Spec.	Size	2.2inch
	Resolution	240 (RGB) x320
	Technology Type	a-si
	Pixel Configuration	R.G.B Vertical Stripe
	Pixel pitch(mm)	0.141x0.141
	Display Mode	ECB Mode, Transflective
	Surface Treatment	Clear(3H)
	Viewing Direction	6 O'Clock
	Gray Scale Inversion Direction	12 O'Clock(IC 6 O'Clock)
Mechanical Characteristics	LCM (W x H x D) (mm)	40.6x56.6x2.7
	Active Area(mm)	33.84mm x 45.12mm
	With /Without TSP	Without TSP
	Matching Connection Type	FH23-39S-0.3SHAW
	LED Numbers	4LEDs serial
	Weight (g)	TBD
Electrical Characteristics	Interface	RGB 18 bits+3SPI
	Color Depth	262K
	Driver IC	ILI9341

Note 1: Viewing direction for best image quality is different from TFT definition. There is a 180 degree shift.

Note 2: Requirements on Environmental Protection: Q/S0002

Note 3: LCM weight tolerance: $\pm 5\%$

2. Input/Output Terminals

Matching connector of FH23-39S-0.3SHAW

No	Symbol	I/O	Description	Comment
1	VL1(LED+)	I	Power supply for LED(High voltage)	
2	VL2(LED-)	I	Power supply for LED(Low voltage)	
3	GND	P	Ground	
4	VDD	P	Power supply of IC	
5	GND	P	Ground	
6	VSYNC	I	Vertical sync. signal	
7	RESET	I	Reset Enable	
8	GND	P	Ground	
9	CS	I	SPI Chip select	
10	SDO	O	SPI serial Data output	
11	SDI	I	SPI serial Data input	
12	GND	P	Ground	
13	SCL	I	SPI serial interface clock	
14	GND	P	Ground	
15	B5	I	Blue data signal	
16	B4	I	Blue data signal	
17	B3	I	Blue data signal	
18	B2	I	Blue data signal	
19	B1	I	Blue data signal	
20	B0	I	Blue data signal	
21	ENABLE	I	Data Enable signal	
22	HSYNC	I	Horizontal sync signal	
23	GND	P	Ground	
24	DCLK	I	Data sampling clock signal	
25	GND	P	Ground	
26	G5	I	Green data signal	
27	G4	I	Green data signal	
28	G3	I	Green data signal	
29	G2	I	Green data signal	
30	G1	I	Green data signal	
31	G0	I	Green data signal	
32	GND	P	Ground	
33	R5	I	Red data signal	
34	R4	I	Red data signal	
35	R3	I	Red data signal	
36	R2	I	Red data signal	
37	R1	I	Red data signal	
38	R0	I	Red data signal	
39	GND	P	Ground	

Note1: I——Input, O——Output, P——Power/Ground

3. Absolute Maximum Ratings

GND=0V

Item	Symbol	MIN	MAX	Unit	Remark
Power Voltage	VDD	-0.3	4.6	V	
Input Voltage	VIN	-0.3	4.6	V	
Back Light Forward Current	I _{LED}		25	mA	
Operating Temperature	T _{OPR}	-20	70	°C	
Storage Temperature	T _{STG}	-30	80	°C	
Relative Humidity Note2	RH	--	≤95	%	Ta ≤ 40°C
		--	≤85	%	40°C < Ta ≤ 50°C
		--	≤55	%	50°C < Ta ≤ 60°C
		--	≤36	%	60°C < Ta ≤ 70°C
		--	≤24	%	70°C < Ta ≤ 80°C
Absolute Humidity	AH	--	≤70	g/m ³	Ta > 70°C

Note1: Input voltage include R0~R5, G0~G5, B0~B5, DCLK, HSYNC, VSYNC, ENABLE, RESET, CS, SDI, SCL

Note2: Ta means the ambient temperature.

It is necessary to limit the relative humidity to the specified temperature range.
Condensation on the module is not allowed.

4. Electrical Characteristics

4.1 LCD Module

VSS=GND, Ta=25°C

Item	Symbol	MIN	TYP	MAX	Unit	Remark
Power Voltage	VDD	2.5	2.8	3.3	V	
Logic Input Voltage	Low Level	V_{IL}	0	—	$0.3 \cdot VDD$	V
	High Level	V_{IH}	$0.7 \cdot VDD$	—	VDD	V
Logic Output Voltage	Low Level	V_{OL}	0	—	$0.2VDD$	V
	High Level	V_{OH}	$0.8VDD$	—	VDD	V

Table 4.1 LCD module electrical characteristics

4.2 Backlight Unit

Ta=25°C

Item	Symbol	MIN	TYP	MAX	Unit	Remark
Forward Current	I_F	-	20	25	mA	Note1
Forward Current Voltage	V_F	12	12.6	14.4	V(4 LEDs)	
Backlight Power Consumption	W_{BL}	-	246	-	mW	
Operating Life Time	-	10000	20000		Hrs	

Table 4.2 Backlight Unit Electrical Characteristics

Note 1: The LED driving condition is defined for total backlight consumption.

Note 2: $I_{LED} = 20 \text{ mA}$ for each LED. Forward Voltage adjusting must depend on Forward Current setting.

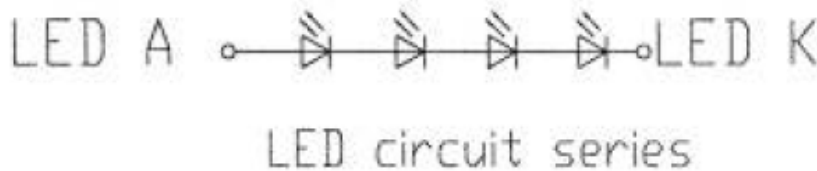
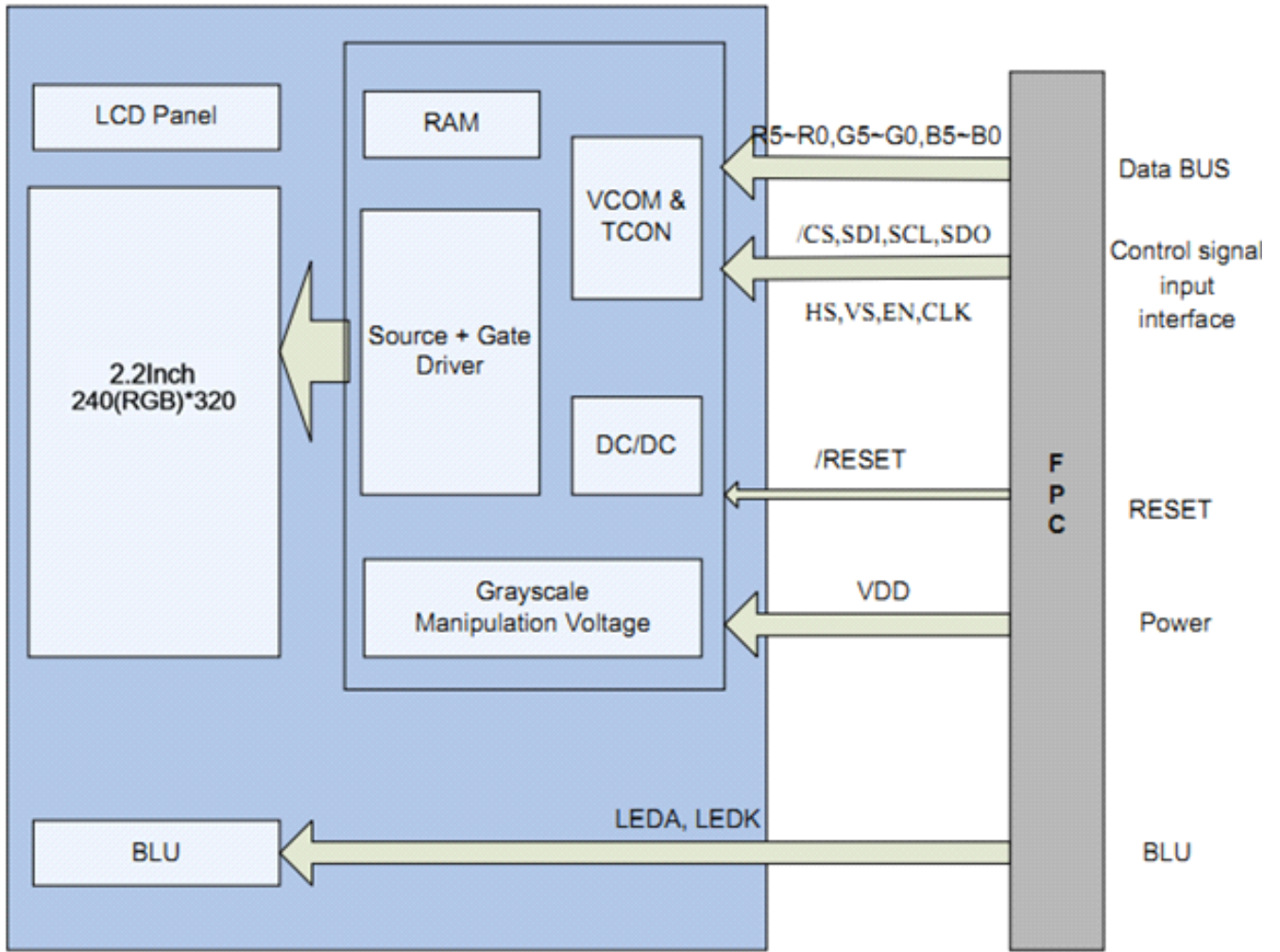

Figure 4.2.1 LED Driver Circuit

4.3 BLOCK DIAGRAM

LCD module diagram



TIANMA

5. Timing Chart

5.1 AC Characteristics

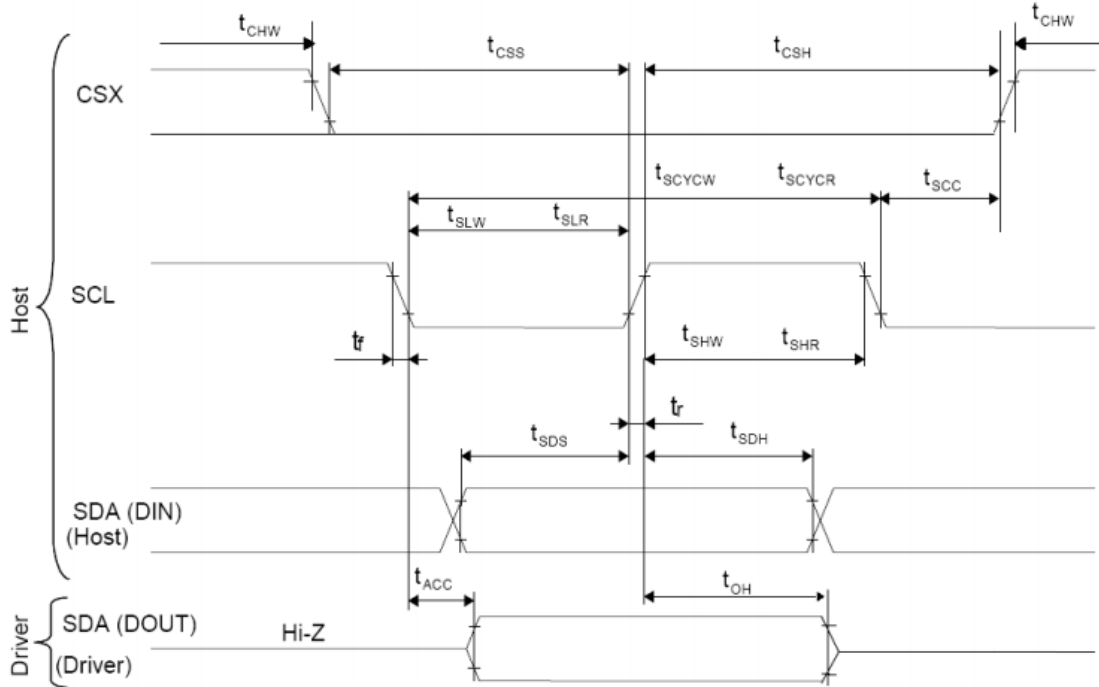

Table 5.1 AC Characteristics

5.2.3 Wire-SPI Interface Input Timing parameters

Signal	Symbol	Parameter	min	max	Unit	Description
SCL	tscycw	Serial Clock Cycle (Write)	100	-	ns	
	tshw	SCL "H" Pulse Width (Write)	40	-	ns	
	tslw	SCL "L" Pulse Width (Write)	40	-	ns	
	tscycr	Serial Clock Cycle (Read)	150	-	ns	
	tshr	SCL "H" Pulse Width (Read)	60	-	ns	
	tslr	SCL "L" Pulse Width (Read)	60	-	ns	
SDA / SDI (Input)	tsds	Data setup time (Write)	30	-	ns	
	tsdh	Data hold time (Write)	30	-	ns	
SDA / SDO (Output)	tacc	Access time (Read)	10	-	ns	
	toh	Output disable time (Read)	10	50	ns	
CSX	tscx	SCL-CSX	20	-	ns	
	tchwh	CSX "H" Pulse Width	40	-	ns	
	tcxss	CSX-SCL Time	60	-	ns	
	tcxsh		65	-	ns	

Note: $T_a = 25\text{ }^\circ\text{C}$, $V_{DDI}=1.65\text{V to }3.3\text{V}$, $V_{CI}=2.5\text{V to }3.3\text{V}$, $AGND=V_{SS}=0\text{V}$

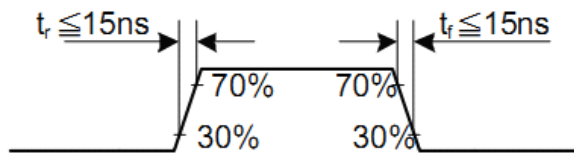

Table 5.2 CPU Input Timing Parameters

5.3 Parallel 18/16/6-bit RGB Interface Timing Characteristics

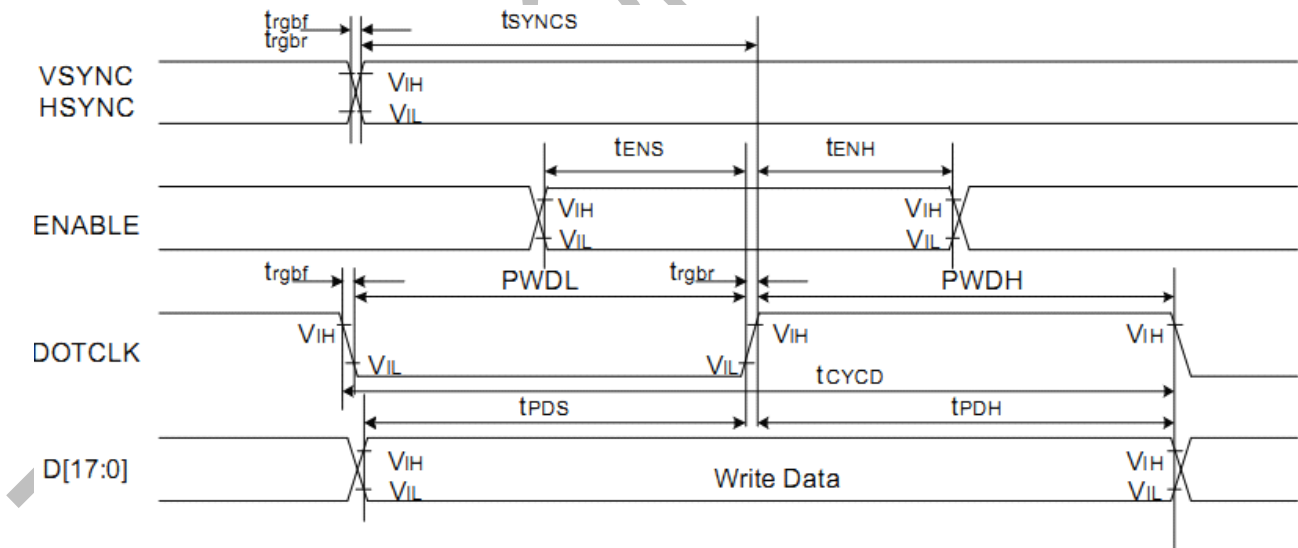
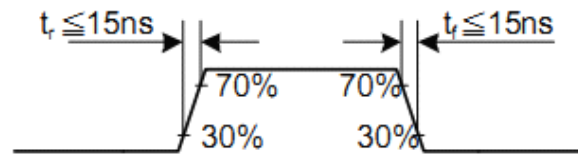

Figure 5.3 Parallel 18/16/6-bit RGB Interface Timing Characteristics

5.4 Parallel 18/16/6-bit RGB Interface Timing parameters

Signal	Symbol	Parameter	min	max	Unit	Description
VSYNC / HSYNC	t_{SYNCS}	VSYNC/HSYNC setup time	15	-	ns	18/16-bit bus RGB interface mode
	t_{SYNCH}	VSYNC/HSYNC hold time	15	-	ns	
DE	t_{ENS}	DE setup time	15	-	ns	
	t_{ENH}	DE hold time	15	-	ns	
D[17:0]	t_{POS}	Data setup time	15	-	ns	
	t_{POH}	Data hold time	15	-	ns	
DOTCLK	PWDH	DOTCLK high-level period	15	-	ns	
	PWDL	DOTCLK low-level period	15	-	ns	
	t_{CYCD}	DOTCLK cycle time	100	-	ns	
	t_{rbr}, t_{rbf}	DOTCLK,HSYNC,VSYNC rise/fall time	-	15	ns	
VSYNC / HSYNC	t_{SYNCS}	VSYNC/HSYNC setup time	15	-	ns	6-bit bus RGB interface mode
	t_{SYNCH}	VSYNC/HSYNC hold time	15	-	ns	
DE	t_{ENS}	DE setup time	15	-	ns	
	t_{ENH}	DE hold time	15	-	ns	
D[17:0]	t_{POS}	Data setup time	15	-	ns	
	t_{POH}	Data hold time	15	-	ns	
DOTCLK	PWDH	DOTCLK high-level pulse period	15	-	ns	
	PWDL	DOTCLK low-level pulse period	15	-	ns	
	t_{CYCD}	DOTCLK cycle time	100	-	ns	
	t_{rbr}, t_{rbf}	DOTCLK,HSYNC,VSYNC rise/fall time	-	15	ns	

Note: $T_a = -30$ to 70 °C, $V_{DDI}=1.65V$ to $3.3V$, $V_{CI}=2.5V$ to $3.3V$, $AGND=VSS=0V$



5.5 Reset timing

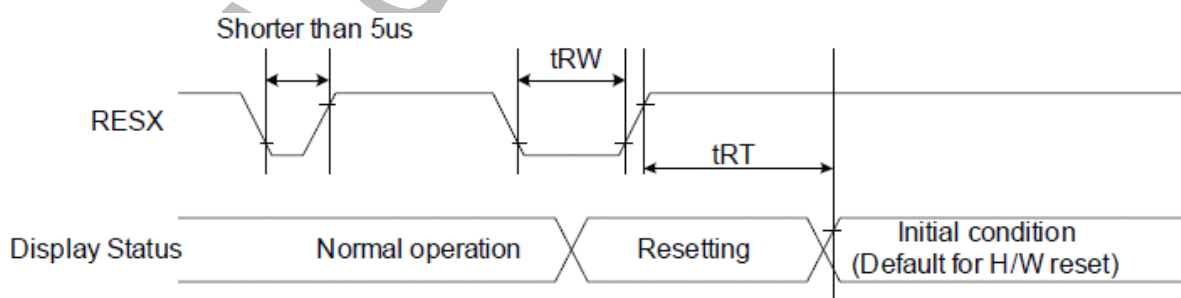

Signal	Symbol	Parameter	Min	Max	Unit
RESX	t_{RW}	Reset pulse duration	10		uS
	t_{RT}	Reset cancel		5 (note 1,5)	mS
				120 (note 1,6,7)	mS

Figure 5.4.1 Reset Timing Diagram

5.6 Power on/off sequence

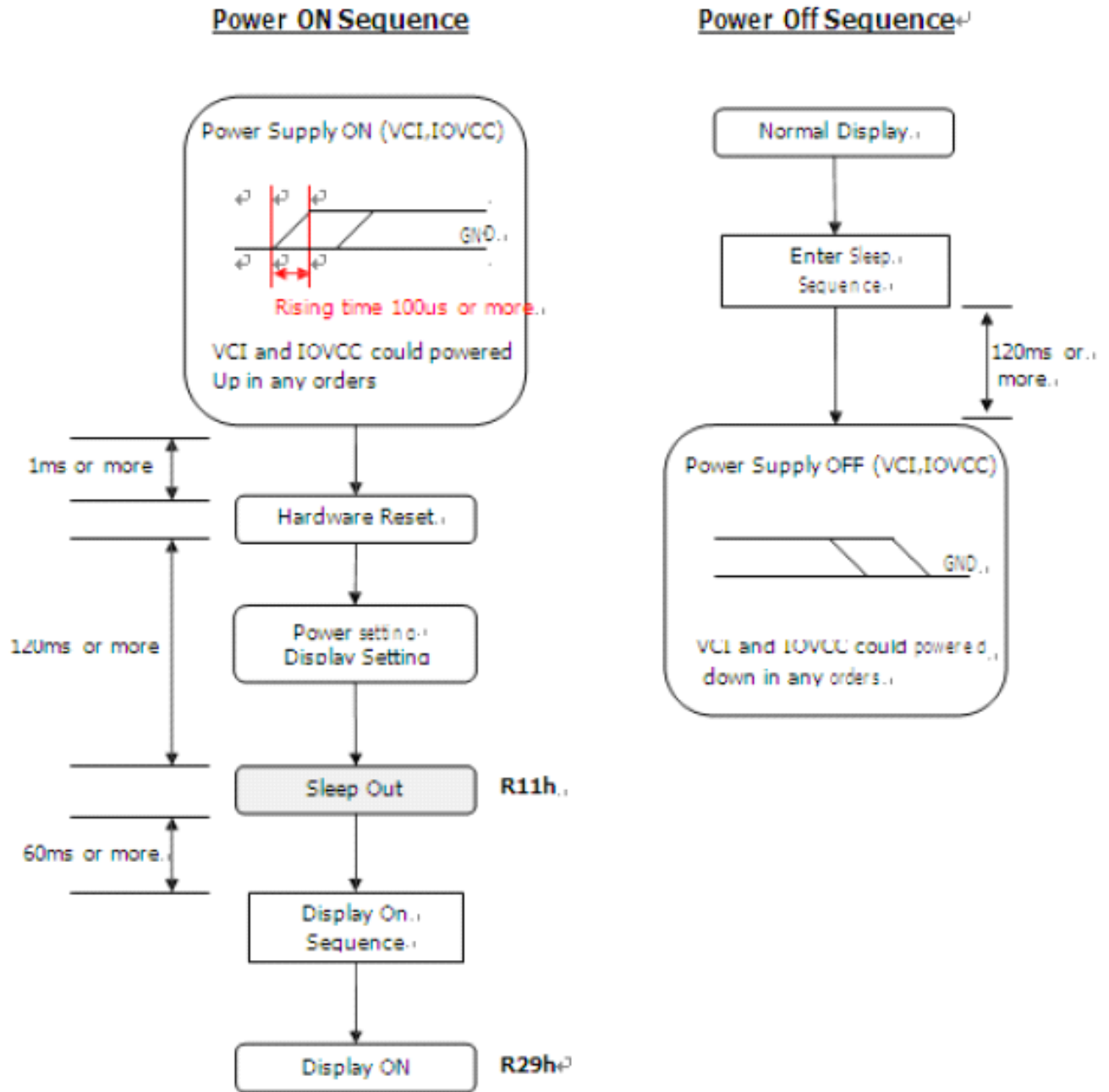

Figure 6.1 Power on/off setting up flow

TIANMA

6 Optical Characteristics

6.1 Driving the backlight condition (Transmissive mode)

Item	Symbol	Condition	Min	Typ	Max	Unit	Remark
View Angles	θT	$CR \geq 10$	38	48		Degree	Note2,3
	θB		35	45			
	θL		30	40			
	θR		40	45			
Contrast Ratio	CR	$\theta=0^\circ$	100	120			Note 3
Response Time	T_{ON}	25°C		35	50	ms	Note 4
	T_{OFF}						
Chromaticity	White	$\theta=0^\circ$	x	0.273	-		Note 1,5
			y	0.296	-		
Luminance	L		80	90		cd/m ²	
Uniformity			70%	80%			Note 7
NTSC			45%	50%			

6.2 Not Driving the backlight condition(Reflective mode)

Item	Symbol	Condition	Min	Typ	Max	Unit	Remark
View Angles	θT	$CR \geq 2$	60	70		Degree	Note1,2,3
	θB		60	70			
	θL		60	70			
	θR		60	70			
Contrast Ratio	CR	$\theta=0^\circ$	7	10			Note 3
Response Time	T_{ON}	25°C		25	40	ms	Note 4
	T_{OFF}						
Reflection ratio			4.8%	5.5%			
NTSC			5.5%	7%			Note 1

Test Conditions:

1. $I_{LED} = 20$ mA, and the ambient temperature is 25°C.
2. The test systems refer to Note 1 and Note 2.

Note 1: Definition of optical measurement system.

1. Transmissive mode: The optical characteristics should be measured in dark room. After 5 Minutes operation, the optical properties are measured at the center point of the LCD screen. All input terminals LCD panel must be ground when measuring the center area of the panel.

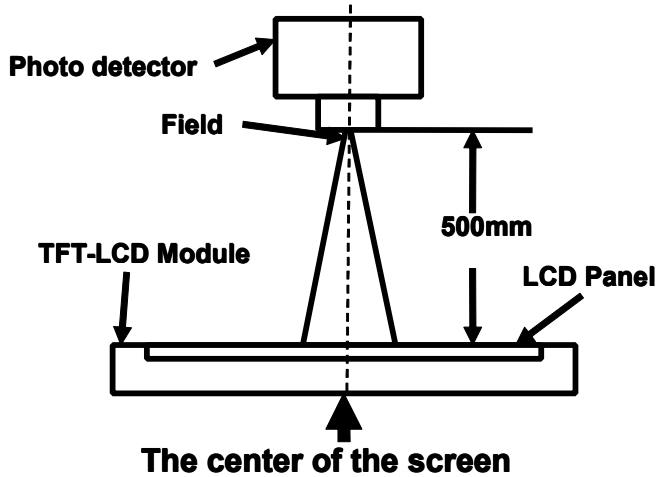

Item	Photo detector	Field
Contrast Ratio	SR-3A	1°
Luminance		
Chromaticity		
Lum Uniformity		
Response Time	BM-7A	2°
Flicker	CA-310	/

2. Reflective mode

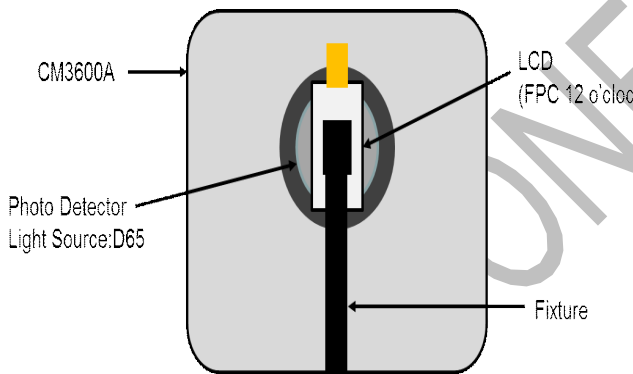

Item	Photo detector	Field
Chromaticity	CM-3600A	
Reflective Ratio		
Contrast Ratio		
Viewing angle	LCD-5200	
Flicker		

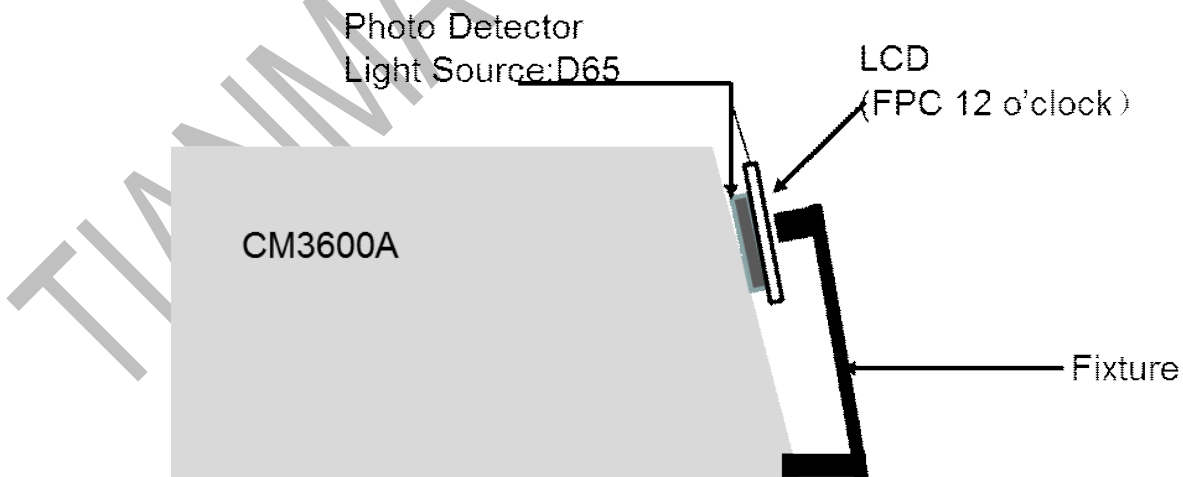

Note 2: Definition of viewing angle range and measurement system.

viewing angle is measured at the center point of the LCD by CONOSCOPE(ergo-80).

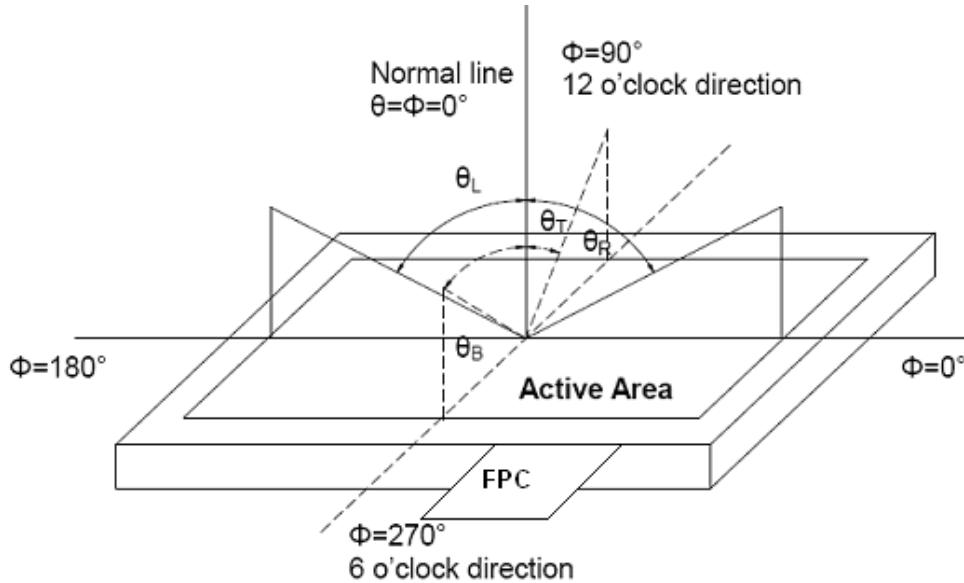

Note 3: Definition of contrast ratio

$$\text{Contrast ratio (CR)} = \frac{\text{Luminance measured when LCD is on the "White" state}}{\text{Luminance measured when LCD is on the "Black" state}}$$

“White state “: The state is that the LCD should drive by V_{white}.

“Black state”: The state is that the LCD should drive by V_{black}.

V_{white}: To be determined V_{black}: To be determined.

Note 4: Definition of Response time

The response time is defined as the LCD optical switching time interval between “White” state and “Black” state. Rise time (T_{ON}) is the time between photo detector output intensity changed from 90% to 10%. And fall time (T_{OFF}) is the time between photo detector output intensity changed from 10% to 90%.

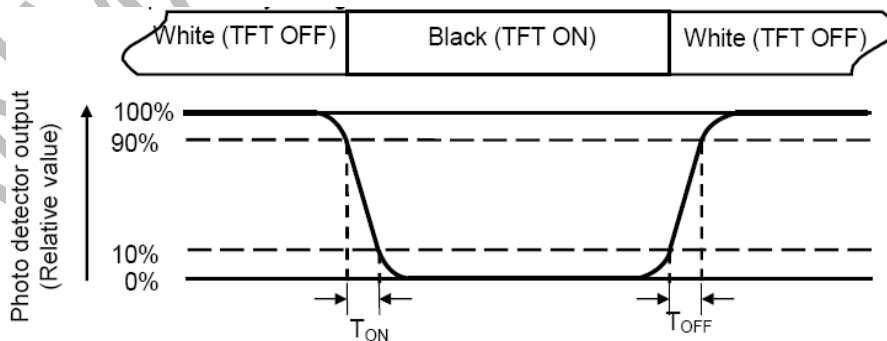

Note 5: Definition of color chromaticity (CIE1931)

- (1) Color coordinates measured at center point of LCD.
- (2) For reflective mode color chromaticity we need to test at least 3 different batches to make sure the stability of panel and it accepts reasonable change after we get the stability data.

The information contained herein is the exclusive property of TIANMA MICRO-ELECTRONICS Corporation and shall not be distributed, reproduced, or disclosed in whole or in part without prior written permission of TIANMA MICRO-ELECTRONICS Corporation.

Note 6: Definition of Luminance Uniformity

Active area is divided into 9 measuring areas (Refer Fig. 2). Every measuring point is placed at the center of each measuring area.

$$\text{Luminance Uniformity (U)} = L_{\min} / L_{\max}$$

L-----Active area length W----- Active area width

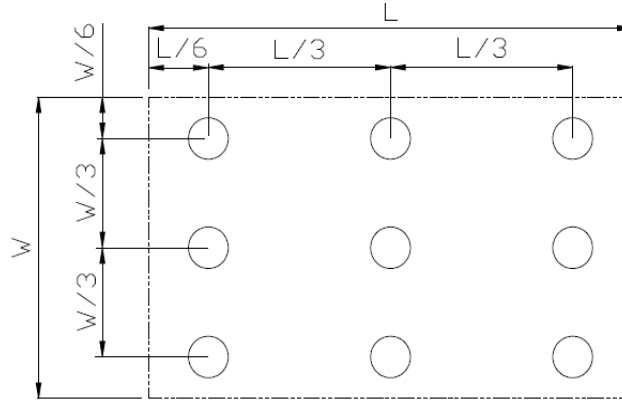

L_{\max} : The measured Maximum luminance of all measurement position.

L_{\min} : The measured Minimum luminance of all measurement position.

Note 7: Definition of Luminance:

Measure the luminance of white state at center point.

TIANMA CONFIDENTIAL

7. Environmental / Reliability Test

No	Test Item	Condition	Remarks
1	High Temperature Operation	T= +70°C, 240 hours	IEC60068-2-1:2007 GB2423.2-2008
2	Low Temperature Operation	Ta = -20°C, 240 hours	IEC60068-2-1:2007 GB2423.1-2008
3	High Temperature Storage	Ta = +80°C, 240 hours	IEC60068-2-1:2007 GB2423.2-2008
4	Low Temperature Storage	Ta = -30°C, 240 hours	IEC60068-2-1:2007 GB2423.1-2008
5	Storage at High Temperature and Humidity	Ta=+60°C, 90% RH 240 hours	IEC60068-2-78 :2001 GB/T2423.3—2006
6	Thermal Shock (non-operation)	-30°C 30 min~+80°C 30 min, Change time:5min, 20 Cycles	Start with cold temperature, End with high temperature, IEC60068-2-14:1984,GB 2423.22-2002
7	ESD	C=150pF, R=330Ω, 5points/panel Air:±8KV, 5times; Contact:±4KV, 5 times; (Environment: 15°C ~ 35°C, 30% ~ 60%, 86Kpa ~ 106Kpa)	IEC61000-4-2:2001 GB/T17626.2-2006
8	Vibration Test	Frequency range:10~55Hz, Stroke:1.5mm Sweep:10Hz~55Hz~10Hz 2 hours for each direction of X.Y.Z. (6 hours for total)(Package condition)	IEC60068-2-6:1982 GB/T2423.10—1995
9	Mechanical Shock (Non OP)	60G 6ms, ±X,±Y,±Z 3times, for each direction	IEC60068-2-27:1987 GB/T2423.5—1995
10	Package Drop Test	Height : 80cm 1corner , 3edges , 6faces	IEC60068-2-32:1990 GB/T2423.8—1995

Note1: Ts is the temperature of panel's surface.

Note2: Ta is the ambient temperature of sample.

Note3: Before cosmetic and function test, the product must have enough recovery time, at least 2 hours at room temperature.

Note 4: In the standard condition, there shall be no practical problem that may affect the display function. After the reliability test, the product only guarantees operation, but don't guarantee all of the cosmetic specification.

9. Packing Drawing

No	Item	Model (Material)	Dimensions(mm)	Unit Weight(Kg)	Quantity	Remark
1	LCM module	TM022HDHT11-00	40.6×56.6×2.7	0.01274	576	
2	Tray	PET(Transmit)	485×330×11.3	0.162	27	
3	Anti static BAG	PE	700X545×0.05	0.046	1	
4	BOX	CORRUGATED PAPER	520×345×70mm	0.227	3	
5	Desiccant	DESICCANT	45×35	0.002	6	
6	Carton	CORRUGATED PAPER	544×365×250	1.01	1	
	Total weight		14.38kg			

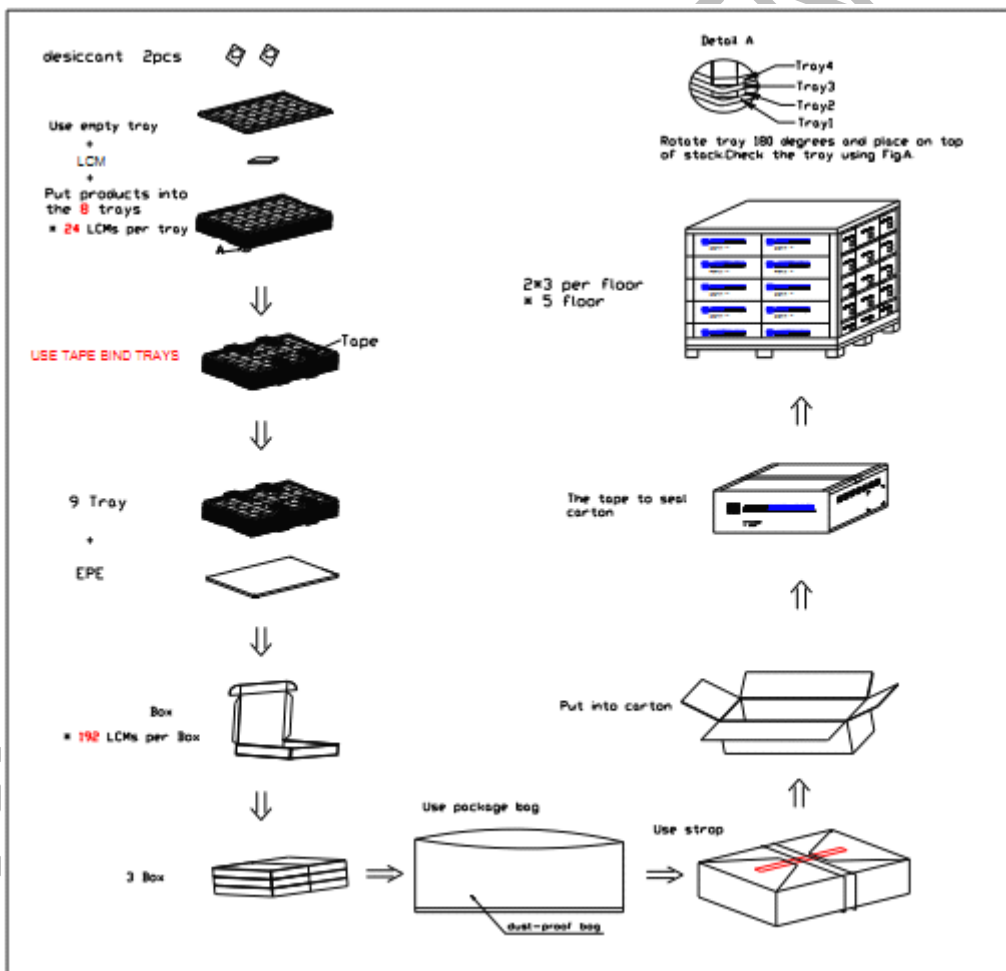

10. Precautions for Use of LCD Modules

1.1 Handling Precautions

1.1.1 The display panel is made of glass. Do not subject it to a mechanical shock by dropping it from a high place, etc.

1.1.2 If the display panel is damaged and the liquid crystal substance inside it leaks out, be sure not to get any in your mouth, if the substance comes into contact with your skin or clothes, promptly wash it off using soap and water.

1.1.3 Do not apply excessive force to the display surface or the adjoining areas since this may cause the color tone to vary.

1.1.4 The polarizer covering the display surface of the LCD module is soft and easily scratched. Handle this polarizer carefully.

1.1.5 If the display surface is contaminated, breathe on the surface and gently wipe it with a soft dry cloth. If still not completely clear, moisten cloth with one of the following solvents:

- Isopropyl alcohol
- Ethyl alcohol

Solvents other than those mentioned above may damage the polarizer. Especially, do not use the following:

- Water
- Ketone
- Aromatic solvents

1.1.6 Do not attempt to disassemble the LCD Module.

1.1.7 If the logic circuit power is off, do not apply the input signals.

1.1.8 To prevent destruction of the elements by static electricity, be careful to maintain an optimum work environment.

10.1.8.1 Be sure to ground the body when handling the LCD Modules.

10.1.8.2 Tools required for assembly, such as soldering irons, must be properly ground.

10.1.8.3 To reduce the amount of static electricity generated, do not conduct assembly and other work under dry conditions.

10.1.8.4 The LCD Module is coated with a film to protect the display surface. Be care when peeling off this protective film since static electricity may be generated.

1.2 Storage precautions

1.2.1 When storing the LCD modules, avoid exposure to direct sunlight or to the light of fluorescent lamps.

1.2.2 The LCD modules should be stored under the storage temperature range. If the LCD modules will be stored for a long time, the recommend condition is:

Temperature : 0°C ~ 40°C Relatively humidity: ≤80%

1.2.3 The LCD modules should be stored in the room without acid, alkali and harmful gas.

1.3 Transportation Precautions

1.3.1 The LCD modules should be no falling and violent shocking during transportation, and also should avoid excessive press, water, damp and sunshine.

The information contained herein is the exclusive property of TIANMA MICRO-ELECTRONICS Corporation and shall not be distributed, reproduced, or disclosed in whole or in part without prior written permission of TIANMA MICRO-ELECTRONICS Corporation.