

PRODUCT DATASHEET

S01.01.02.232 _ AMPERE-D37-1-36

1.General Information

- ✓ Material : PMMA
- ✓ Size : D37 (mm)
- ✓ FWHM : 36
- ✓ Design LED : CREE XPE 3535
- ✓ Compatible LED size : 3535/5050/3030
- ✓ Efficiency : 93%
- ✓ Fasten : Pin+Frame
- ✓ IP class : N/A
- ✓ Accessories : Conical Holder With Position Pin
- ✓ RoHS : YES
- ✓ Surface : Bead

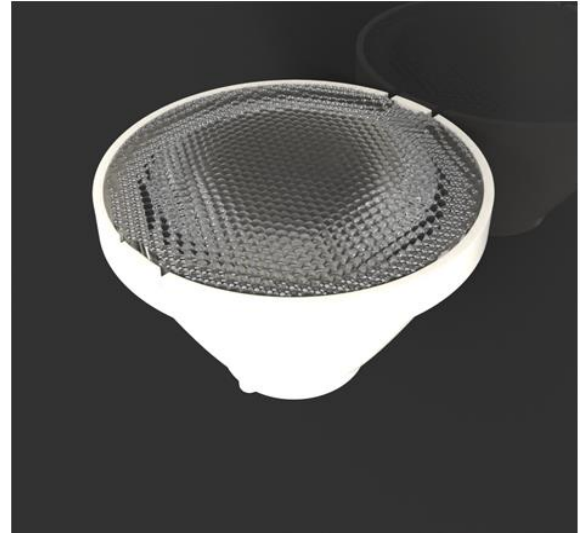

2.MECHANICAL SPECIFICATION

UNIT:MM

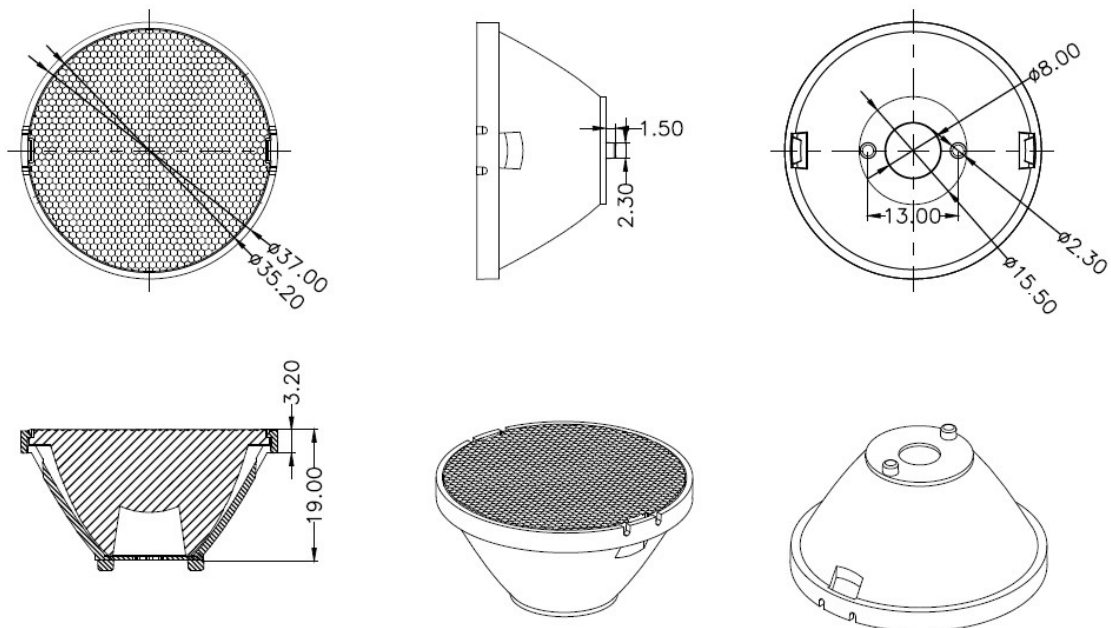

3.OPTICAL DATA

1) Simulation Data

LED model : N/A
Light colour : N/A
FWTM : N/A
FWHM : N/A

2) Test Data

LED model : CREE XPE 3535
Light colour : White
FWTM : H66.5°,V66.6°
FWHM : H33.7°,V33.7°
Remark : N/A

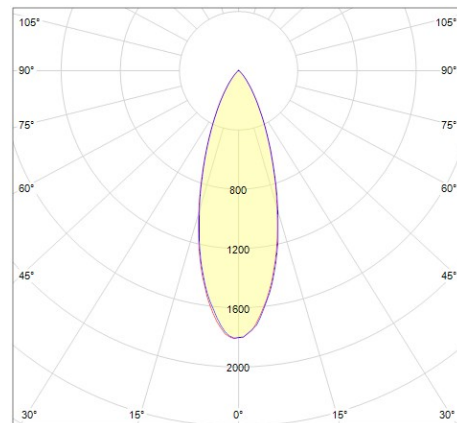

4.Usage and Maintenance

- 1) If necessary, clean lenses with mild soap, water and soft cloth.
- 2) Never use any commercial cleaning solvents on lenses, like alcohol.
- 3) Please handle lens with wearing gloves, skin oils may damage lens or its optical characteristic.

5.Note

Please test the data again before using. The chart data is for reference only.