

**TITLE : DV270FHM-P20**  
**Fianl Product Specification**  
**Rev.O**

Fuzhou BOE Optoelectronics Technology Co.,Ltd

**REVISION HISTORY**

( ) Preliminary specification

(●) Final specification

Revision No.	Page	Description of changes	Date	Prepared
P0		Initial Release	2021.11.24	Feng xin
O		Final	2022.03.11	Feng xin

## Contents

No.	Item	Page
	Revisions History	
	Contents	
1.0	General Description	4
2.0	Absolute Maximum Ratings	6
3.0	Electrical Specifications	7
4.0	Optical Specifications	9
5.0	Interface Connection	11
6.0	Signal Timing Specifications	12
7.0	Signal Timing Waveforms of Interface Signal	14
8.0	Input Signals, Display Colors & Gray Scale of Colors	16
9.0	Power Sequence	17
10.0	Mechanical Characteristics	18
11.0	Reliability Test	19
12.0	Handling & Cautions	20
13.0	Product Serial Number	25
14.0	Packing	26
15.0	Appendix	28

## 1.0 GENERAL DESCRIPTION

### 1.1 Introduction

DV270FHM-N11 is a color active matrix TFT LCD module using amorphous silicon TFT's (Thin Film Transistors) as an active switching devices. This module has a 27 inch diagonally measured active area with FHD resolutions (1920 horizontal by 1080 vertical pixel array). Each pixel is divided into RED, GREEN, BLUE dots which are arranged in vertical stripe and this module can display 16.7M colors. The TFT-LCD panel used for this module is adapted for a low reflection and higher color type.

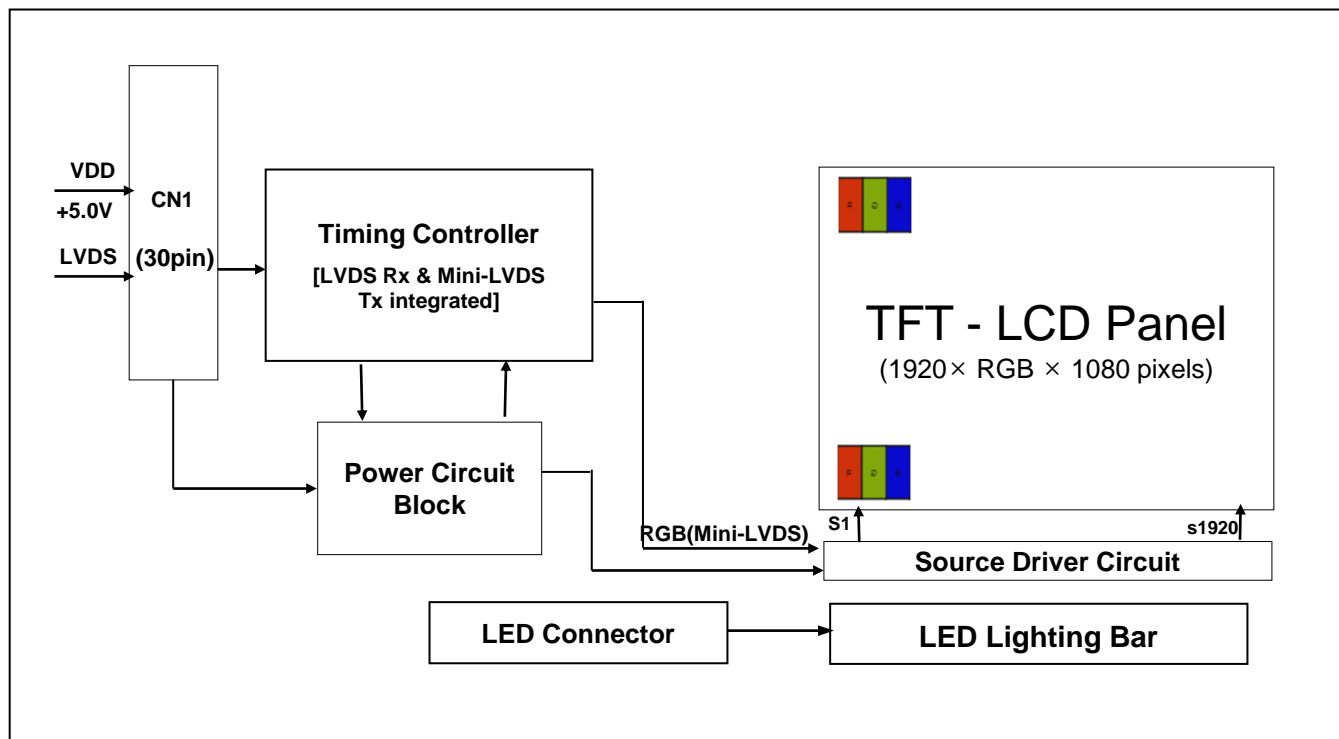

### 1.2 Features

- LVDS Interface with 2 pixel / clock
- 8-bit (6-bit+FRC) color depth, display 16.7MB colors
- Color Gamut 72%@NTSC(CIE 1931)
- ES8.0 compliant
- High luminance and contrast ratio, low reflection and wide viewing angle
- DE (Data Enable) only
- RoHS/Halogen Free
- Gamma Correction
- Reverse type

### 1.3 Application

- Desktop Type of PC & Workstation Use
- Slim-Size Display for Stand-alone Monitor
- Display Terminals for Control System
- Monitors for Process Controller

### 1.4 General Specification

The followings are general specifications at the model DV270FHM-N11.

<Table 1. General Specifications>

Parameter	Specification	Unit	Remarks
Active area	597.888(H) × 336.312(V)	mm	
Number of pixels	1920(H) × 1080 (V)	pixels	
Pixel pitch	0.3114 (H) × 0.3114(V)	mm	
Pixel arrangement	RGB Vertical stripe		
Display colors	16.7M	colors	6-bit+FRC
Display mode	Normally Black		
Dimensional outline	630×368×9.5(w/o PCB);13.5(with PCB)	mm	
Weight	3220typ,3500 max	g	
Power Consumption	16.02W(Typ), 19.03W(MAX)	Watt	
Surface Treatment	Haze 25%, 3H		
Bezel width (L/R/U/D)	14/14/14.5/13.9	mm	
Back-light	ELED		

### 2.0 ABSOLUTE MAXIMUM RATINGS

The followings are maximum values which, if exceed, may cause faulty operation or damage to the unit. The operational and non-operational maximum voltage and current values are listed in Table 2.

< Table 2. Absolute Maximum Ratings >

[VSS=GND=0V]

Parameter	Symbol	Min.	Max.	Unit	Remark
Power Supply Voltage	VDD	VSS-0.3	6	V	Ta = 25 °C
Operating Temperature	T <sub>OP</sub>	0	+50	°C	Note 1
	T <sub>SUR</sub>	-	+65	°C	
Storage Temperature	T <sub>ST</sub>	-20	+60	°C	
Operating Ambient Humidity	Hop	10	80	%RH	
Storage Humidity	Hst	10	80	%RH	

Note : 1) Temperature and relative humidity range are shown in the figure below.  
Wet bulb temperature should be 39 °C max. and no condensation of water.

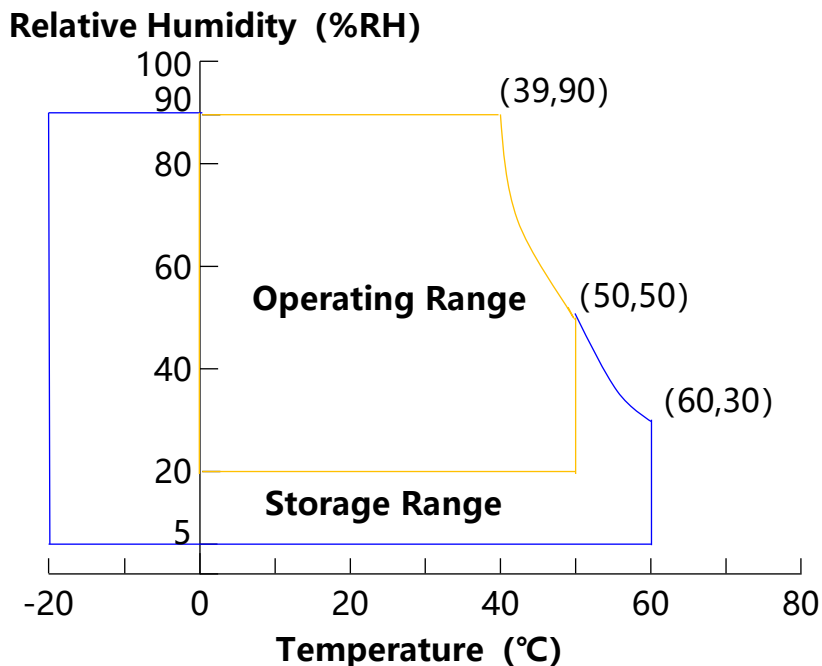

### 3.0 ELECTRICAL SPECIFICATIONS

#### 3.1 Electrical Specifications

< Table 3. Open Cell Electrical specifications >

[Ta = 25 ± 2 °C]

Parameter		Min.	Typ.	Max.	Unit	Remarks
Power Supply Voltage	VDD	4.5	5	5.5	V	Note 1
Power Supply Current	IDD	-	640	1060	mA	
In-Rush Current	IRUSH	-	2.0	3.0	A	Note 2
Permissible Input Ripple Voltage	VRF	-	-	400	mV	Note 1,3
High Level Differential Input Threshold Voltage	VIH	+100	-	+300	mV	
Low Level Differential Input Threshold Voltage	VIL	-300	-	-100	mV	
Differential input voltage	VID	200	-	600	mV	
Differential input common mode voltage	Vcm	1.0	1.2	1.5		VIH=100mV, VIL=-100mV
Power Consumption	PD	-	3.2	5.3	W	
	PBL		12.82	13.73	W	

Notes : 1. The supply voltage is measured and specified at the interface connector of LCM.  
The current draw and power consumption specified is for VDD=5.0V, Frame rate=60Hz  
Clock frequency = 74.25 MHz. Test Pattern of power supply current

- a) Typ : Color Test
- b) Max : Skip Subpixel255
- c) Flicker Pattern

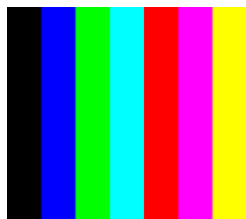

(a)

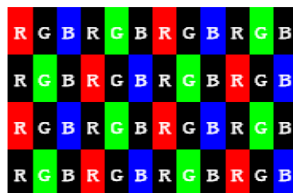

(b)

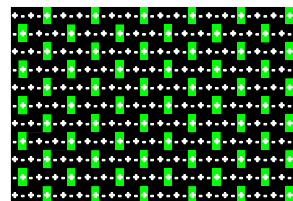

(c)

- 2. Duration of rush current is about 2 ms and rising time of VDD is 520 μs ± 20 %
- 3. Ripple Voltage should be covered by Input voltage Spec.
- 4. Calculated value for reference (Input pins\*VPIN × IPIN) excluding inverter loss.

**3.2 Backlight Unit**

&lt; Table 4. Backlight Unit Electrical Specifications &gt;

Parameter		Min.	Typ.	Max.	Unit	Remarks
LED Light Bar Input Voltage Per Input Pin	VPI N		30.8	33	V	Duty 100%
LED Light Bar Input Current Per Input Pin	IPIN		104	-	mA	Note1,2,
LED Power Consumption	PBL		12.82	13.73	W	Note 3
LED Life-Time	-	30,000	-		Hrs	Note 4

LED bar consists of 88LED packages,8 strings(parallel)\*11packages(serial)

Note1: There are one light bar ,and the specified current is input LED chip 100% duty current

Note2: The sense current of each input pin is 104mA, LED Bar ( 4 Input pins)

Note3:  $PBL=4 \text{ Input pins} \times VPI \times IPIN$

Note4: The lifetime is determined as the time at which luminance of LED become 50% of the initial brightness or not normal lighting at  $IPIN=104mA$  on condition of continuous operating at  $25 \pm 2 \text{ } ^\circ\text{C}$

**3.3 LED Light Bar**

-LED connector : A1009AWV(6)

&lt; Table 5. LED Light Bar &gt;

Pin No	Symbol	Description
1	IRLED1	LED current sense for string1
2	IRLED2	LED current sense for string2
3	VLED	LED power supply
4	VLED	LED power supply
5	IRLED3	LED current sense for string3
6	IRLED4	LED current sense for string4

## 4.0 OPTICAL SPECIFICATION

### 4.1 Overview

The test of Optical specifications shall be measured in a dark room (ambient luminance  $\leq 1$  lux and temperature =  $25 \pm 2^\circ\text{C}$ ) with the equipment of Luminance meter system (Goniometer system and TOPCONE PR730) and test unit shall be located at an approximate distance 50cm from the LCD surface at a viewing angle of  $\theta$  and  $\Phi$  equal to  $0^\circ$ . We refer to  $\theta_{\theta=0}$  ( $=\theta_3$ ) as the 3 o'clock direction (the "right"),  $\theta_{\theta=90}$  ( $=\theta_{12}$ ) as the 12 o'clock direction ("upward"),  $\theta_{\theta=180}$  ( $=\theta_9$ ) as the 9 o'clock direction ("left") and  $\theta_{\theta=270}$  ( $=\theta_6$ ) as the 6 o'clock direction ("bottom"). While scanning  $\theta$  and/or  $\Phi$ , the center of the measuring spot on the Display surface shall stay fixed. The measurement shall be executed after 30 minutes warm-up period. VDD shall be 5.0V +/-10% at  $25^\circ\text{C}$ . Optimum viewing angle direction is 6 'clock.

### 4.2 Optical Specifications

[VDD = 5.0V, Frame rate = 60Hz, Clock = 74.25MHz,  $I_{BL} = 416\text{mA}$ ,  $T_a = 25 \pm 2^\circ\text{C}$ ]

< Table 5. Module Optical >

Parameter		Symbol	Condition	Min.	Typ.	Max.	Unit	Remark
Viewing Angle range	Horizontal	$\Theta_3$	CR > 10	85	89	-	Deg.	Note 1
		$\Theta_9$		85	89	-	Deg.	
	Vertical	$\Theta_{12}$		85	89	-	Deg.	
		$\Theta_6$		85	89	-	Deg.	
Luminance Contrast ratio		CR	$\Theta = 0^\circ$ (Center) Normal Viewing Angle	700	1000			Note 2
Luminance of White		$Y_{w1}$		250	300	-		Note 3
		$Y_{w2}$		250	-	-		Note 4
Colour gamut		CG		68	72		%	NTSC
White luminance uniformity		$\Delta Y1$		75	80		%	Note 5
		$\Delta Y2$		80	85		%	Note 6
Reproduction of color	White	$W_x$		-0.03	+0.03	0.313	-	Note 7
		$W_y$				0.329	-	
	Red	$R_x$				0.648	-	
		$R_y$				0.341	-	
	Green	$G_x$	0.323			-		
		$G_y$	0.625			-		
	Blue	$B_x$	0.156			-		
		$B_y$	0.054			-		
Response Time	GTG	$T_g$		14	20	ms	Note 8	
Cross Talk		CT		-	-	2.0	%	Note 9

**Note :**

1. Viewing angle is the angle at which the contrast ratio is greater than 10. The viewing are determined for the horizontal or 3, 9 o'clock direction and the vertical or 6, 12 o'clock direction with respect to the optical axis which is normal to the LCD surface.
2. Contrast measurements shall be made at viewing angle of  $\theta = 0^\circ$  and at the center of the LCD surface. Luminance shall be measured with all pixels in the view field set first to white, then to the dark (black) state. (See FIGURE 1 shown in Appendix) Luminance Contrast Ratio (CR) is defined mathematically.

$$CR = \frac{\text{Luminance when displaying a white raster}}{\text{Luminance when displaying a black raster}}$$

3. Center Luminance of white is defined as the LCD surface. Luminance shall be measured with all pixels in the view field set first to white. This measurement shall be taken at the locations shown in FIGURE 2 for a total of the measurements per display.
4. Average (P1~P5) Luminance of white is defined as the LCD surface. Luminance shall be measured with all pixels in the view field set first to white. This measurement shall be taken at the locations shown in FIGURE 2 for a total of the measurements per display.
5. The White luminance uniformity on LCD surface is then expressed as :  
 $\Delta Y = ( \text{Minimum Luminance of P1~P13points} / \text{Maximum Luminance of P1~ P13points} ) * 100$  (See FIGURE 2 shown in Appendix).
6. The White luminance uniformity on LCD surface is then expressed as :  
 $\Delta Y = ( \text{Minimum Luminance of P1~ P5points} / \text{Maximum Luminance of P1~ P5points} ) * 100$  (See FIGURE 2 shown in Appendix).
7. The color chromaticity coordinates specified in Table 5. shall be calculated from the spectral data measured with all pixels first in red, green, blue and white. Measurements shall be made at the center of the panel.
8. Response time Tg is the average time required for display transition by switching the input signal as below table and is based on Frame rate fV =60Hz to optimize.  
 Each time in below table is defined as appendix Figure 3 and shall be measured by switching the input signal for "any level of gray(bright)"and "any level of gray(dark)"
9. Cross-Talk of one area of the LCD surface by another shall be measured by comparing the luminance ( $Y_A$ ) of a 25mm diameter area, with all display pixels set to a gray level, to the luminance ( $Y_B$ ) of that same area when any adjacent area is driven dark. (See FIGURE 4 shown in Appendix).

## 5.0 INTERFACE CONNECTION.

### 5.1 Electrical Interface Connection

- CN1 Module Side Connector : UJU IS100-L300-C23or Equivalent

Pin No	Symbol	Function	Remark
1	RXO0N	Negative LVDS differential data input	
2	RXO0P	Positive LVDS differential data input	
3	RXO1N	Negative LVDS differential data input	
4	RXO1P	Positive LVDS differential data input	
5	RXO2N	Negative LVDS differential data input	
6	RXO2P	Positive LVDS differential data input	
7	BIST	BIST	
8	RXOCN-	Negative LVDS differential clock input	
9	RXOCP	Positive LVDS differential clock input	
10	RXO3N	Negative LVDS differential data input	
11	RXO3P	Positive LVDS differential data input	
12	RXE0N	Negative LVDS differential data input	
13	RXE0P	Positive LVDS differential data input	
14	GND	Ground	
15	RXE1N	Negative LVDS differential data input	
16	RXE1P	Positive LVDS differential data input	
17	GND	Ground	
18	RXE2N	Negative LVDS differential data input	
19	RXE2P	Positive LVDS differential data input	
20	RXECN	Negative LVDS differential clock input	
21	RXECP	Positive LVDS differential clock input	
22	RXE3N	Negative LVDS differential data input	
23	RXE3P	Positive LVDS differential data input	
24	GND	Ground	
25	SCL	I2C Clock (For VCOM tuning )	
26	SDA	I2C Data (For VCOM tuning)	
27	NC	NC	
28	VIN	Power Supply 5V	
29	VIN	Power Supply 5V	
30	VIN	Power Supply 5V	

**6.0 SIGNAL TIMING SPECIFICATION**

6.1 The DV270FHM-N11 is operated by the DE only.

Item	Symbols		Min	Typ	Max	Unit	Note
DCLK	Period	tCLK	10.78	13.47	16.16	ns	
	Frequency	fCLK	61.87	74.25	92.8	MHz	
Hsync	Period	tHP	1050	1100	1120	tCLK	
	Horizontal Valid	tHV	960	960	960	tCLK	
	Horizontal Blank	tHB	90	140	160	tCLK	
	Frequency	fH	56	67.5	84.5	KHz	
Vsync	Period	tVP	1110	1125	1251	tHP	
	Vertical Valid	tVV	1080	1080	1080	tHP	
	Vertical Blank	tVB	30	45	171	tHP	
	Frequency	fV	50	60	75	Hz	
LVDS Receiver clock	Input spread spectrum ratio	SSr	-3%	-	+3%	%	

### 6.2 LVDS Rx Interface Timing Parameter

The specification of the LVDS Rx interface timing parameter is shown in Table 7.

<Table 7. LVDS Rx Interface Timing Specification>

Item	Symbol	Min	Typ	Max	Unit	Remark
CLKIN Period	tRCIP	10.78	13.47	16.16	nsec	
Input Data 0	tRIP1	-0.4	0.0	+0.4	nsec	
Input Data 1	tRIP0	tRCIP/7-0.4	tRCIP/7	tRCIP/7+0.4	nsec	
Input Data 2	tRIP6	2 × tRCIP/7-0.4	2 × tRCIP/7	2 × tRCIP/7+0.4	nsec	
Input Data 3	tRIP5	3 × tRCIP/7-0.4	3 × tRCIP/7	3 × tRCIP/7+0.4	nsec	
Input Data 4	tRIP4	4 × tRCIP/7-0.4	4 × tRCIP/7	4 × tRCIP/7+0.4	nsec	
Input Data 5	tRIP3	5 × tRCIP/7-0.4	5 × tRCIP/7	5 × tRCIP/7+0.4	nsec	
Input Data 6	tRIP2	6 × tRCIP/7-0.4	6 × tRCIP/7	6 × tRCIP/7+0.4	nsec	

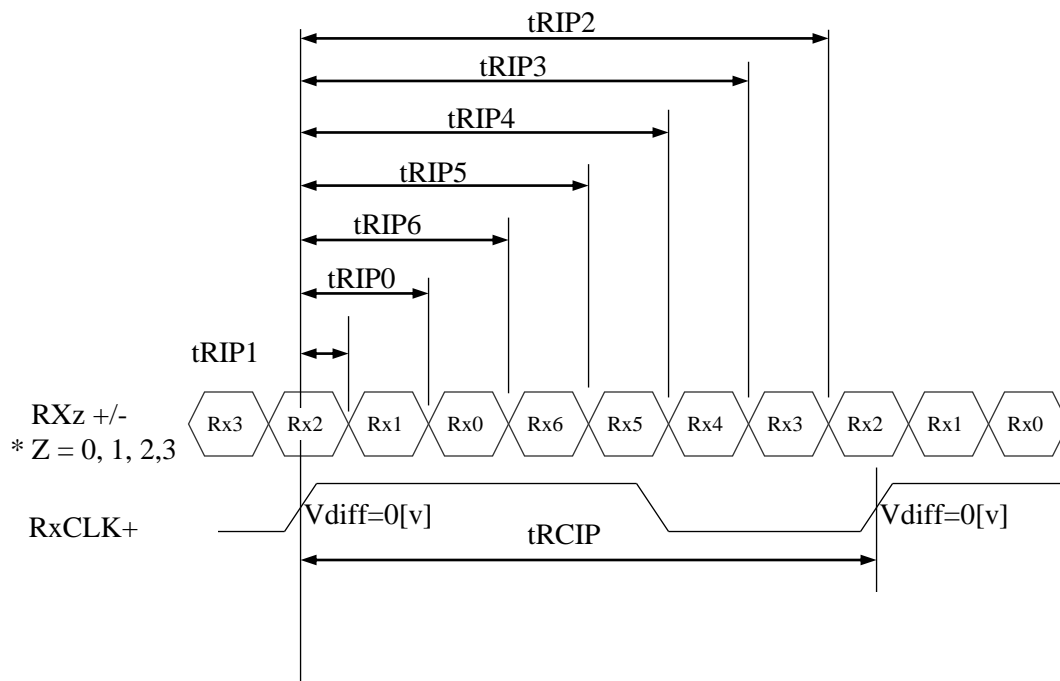

\*  $V_{diff} = (RXz+) - (RXz-), \dots, (RXCLK+) - (RXCLK-)$

## 7.0 SIGNAL TIMING WAVEFORMS OF INTERFACE SIGNAL

### 7.1 Sync Timing Waveforms

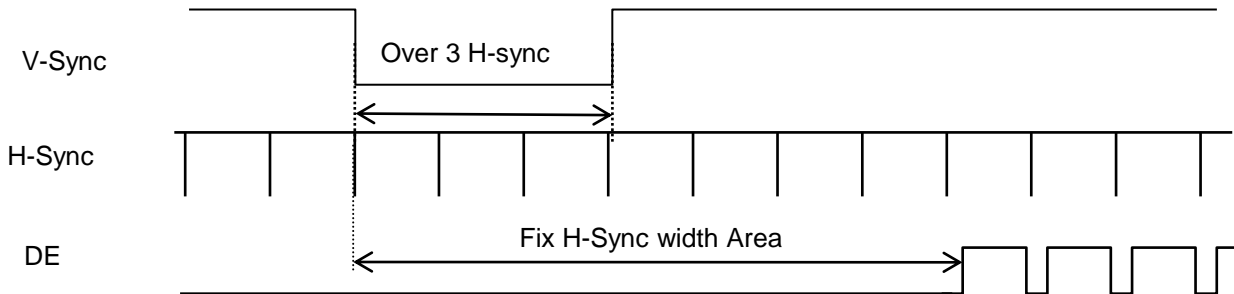

- 1) Need over 3 H-sync during V-Sync Low
- 2) Fix H-Sync width from V-Sync falling edge to first rising edge

### 7.2 Vertical Timing Waveforms

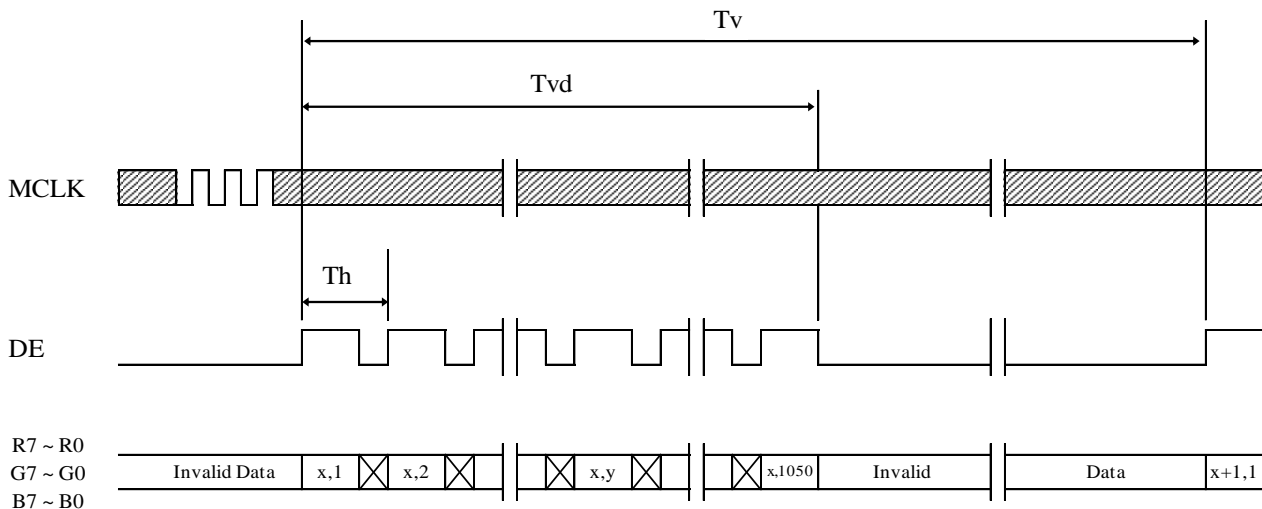

### 7.3 Horizontal Timing Waveforms

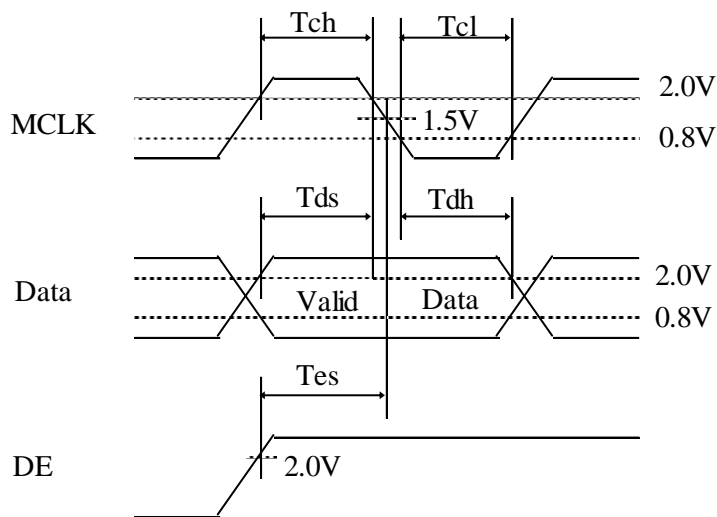
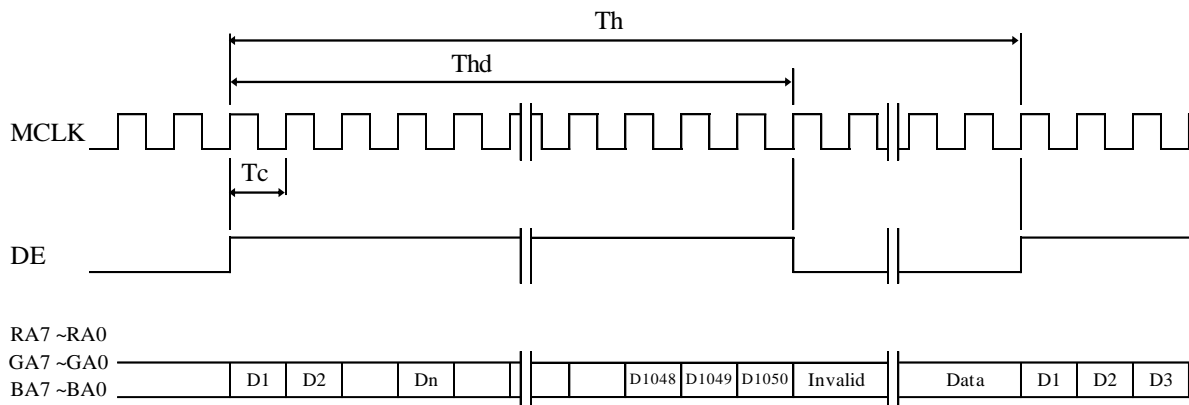

## 8.0 INPUT SIGNALS, BASIC DISPLAY COLORS & GRAY SCALE OF COLORS

Color & Gray Scale		RED DATA								GREEN DATA								BLUE DATA							
		R7	R6	R5	R4	R3	R2	R1	R0	G7	G6	G5	G4	G3	G2	G1	G0	B7	B6	B5	B4	B3	B2	B1	B0
Basic Colors	Black	0	0	0	0	0	0	0	0	0	0	0	0	0	0	0	0	0	0	0	0	0	0	0	0
	Blue	0	0	0	0	0	0	0	0	0	0	0	0	0	0	0	0	1	1	1	1	1	1	1	1
	Green	0	0	0	0	0	0	0	0	1	1	1	1	1	1	1	1	0	0	0	0	0	0	0	0
	Cyan	0	0	0	0	0	0	0	0	1	1	1	1	1	1	1	1	1	1	1	1	1	1	1	1
	Red	1	1	1	1	1	1	1	1	0	0	0	0	0	0	0	0	0	0	0	0	0	0	0	0
	Magenta	1	1	1	1	1	1	1	1	0	0	0	0	0	0	0	0	1	1	1	1	1	1	1	1
	Yellow	1	1	1	1	1	1	1	1	1	1	1	1	1	1	1	1	0	0	0	0	0	0	0	0
	White	1	1	1	1	1	1	1	1	1	1	1	1	1	1	1	1	1	1	1	1	1	1	1	1
Gray Scale of RED	Black	0	0	0	0	0	0	0	0	0	0	0	0	0	0	0	0	0	0	0	0	0	0	0	0
	△	0	0	0	0	0	0	0	1	0	0	0	0	0	0	0	0	0	0	0	0	0	0	0	0
	Darker	0	0	0	0	0	0	1	0	0	0	0	0	0	0	0	0	0	0	0	0	0	0	0	0
	△	↑								↑								↑							
	▽	↓								↓								↓							
	Brighter	1	1	1	1	1	1	0	1	0	0	0	0	0	0	0	0	0	0	0	0	0	0	0	0
	▽	1	1	1	1	1	1	1	0	0	0	0	0	0	0	0	0	0	0	0	0	0	0	0	0
	Red	1	1	1	1	1	1	1	1	0	0	0	0	0	0	0	0	0	0	0	0	0	0	0	0
Gray Scale of GREEN	Black	0	0	0	0	0	0	0	0	0	0	0	0	0	0	0	0	0	0	0	0	0	0	0	0
	△	0	0	0	0	0	0	0	0	0	0	0	0	0	0	0	1	0	0	0	0	0	0	0	0
	Darker	0	0	0	0	0	0	0	0	0	0	0	0	0	0	1	0	0	0	0	0	0	0	0	0
	△	↑								↑								↑							
	▽	↓								↓								↓							
	Brighter	0	0	0	0	0	0	0	0	1	1	1	1	1	1	0	1	0	0	0	0	0	0	0	0
	▽	0	0	0	0	0	0	0	0	1	1	1	1	1	1	1	0	0	0	0	0	0	0	0	0
	Green	0	0	0	0	0	0	0	0	1	1	1	1	1	1	1	1	0	0	0	0	0	0	0	0
Gray Scale of BLUE	Black	0	0	0	0	0	0	0	0	0	0	0	0	0	0	0	0	0	0	0	0	0	0	0	0
	△	0	0	0	0	0	0	0	0	0	0	0	0	0	0	0	0	0	0	0	0	0	0	0	1
	Darker	0	0	0	0	0	0	0	0	0	0	0	0	0	0	0	0	0	0	0	0	0	0	1	0
	△	↑								↑								↑							
	▽	↓								↓								↓							
	Brighter	0	0	0	0	0	0	0	0	0	0	0	0	0	0	0	0	1	1	1	1	1	1	0	1
	▽	0	0	0	0	0	0	0	0	0	0	0	0	0	0	0	0	1	1	1	1	1	1	1	0
	Blue	0	0	0	0	0	0	0	0	0	0	0	0	0	0	0	0	1	1	1	1	1	1	1	1
Gray Scale of WHITE	Black	0	0	0	0	0	0	0	0	0	0	0	0	0	0	0	0	0	0	0	0	0	0	0	0
	△	0	0	0	0	0	0	0	1	0	0	0	0	0	0	0	1	0	0	0	0	0	0	0	1
	Darker	0	0	0	0	0	0	1	0	0	0	0	0	0	0	1	0	0	0	0	0	0	0	1	0
	△	↑								↑								↑							
	▽	↓								↓								↓							
	Brighter	1	1	1	1	1	1	0	1	1	1	1	1	1	1	0	1	1	1	1	1	1	1	0	1
	▽	1	1	1	1	1	1	1	0	1	1	1	1	1	1	1	0	1	1	1	1	1	1	1	0
	White	1	1	1	1	1	1	1	1	1	1	1	1	1	1	1	1	1	1	1	1	1	1	1	1

## 9.0 POWER SEQUENCE

To prevent a latch-up or DC operation of the LCD module, the power on/off sequence shall be as shown in below

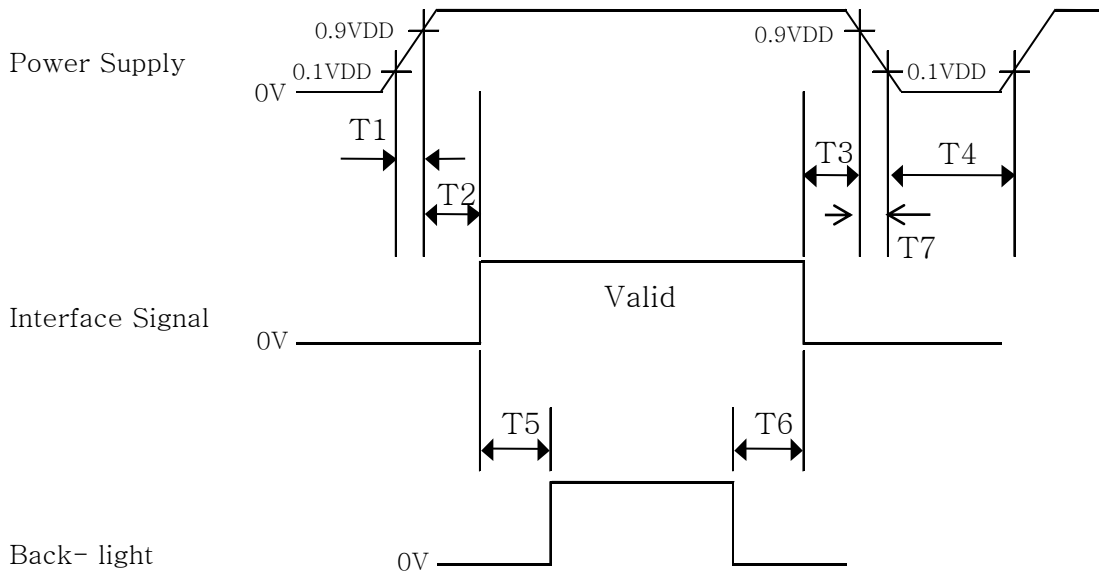

- $0.5 \text{ ms} \leq T1 \leq 10 \text{ ms}$
- $0 \leq T2 \leq 50 \text{ ms}$
- $0 \leq T3 \leq 50 \text{ ms}$
- $1 \text{ sec} \leq T4$
- $500 \text{ ms} \leq T5$
- $200 \text{ ms} \leq T6$

### Notes:

1. When the power supply VDD is 0V, keep the level of input signals on the low or keep high impedance.
2. Do not keep the interface signal high impedance when power is on.
3. Back Light must be turn on after power for logic and interface signal are valid.
4. T7 decreases smoothly, there is none re-bouncing voltage.

## 10.0 MECHANICAL CHARACTERISTICS

### 10.1 Dimensional Requirements

FIGURE 6 (located in Appendix) shows mechanical outlines for the model DV270FHM-N11. Other parameters are shown in Table 8.

<Table 8. Dimensional Parameters>

Parameter	Specification	Unit
Dimensional outline	630×368×9.5 (w/o PCB);13.5(with PCB)	mm
Weight	3220typ,3500 max	gram
Active area	597.888(H) × 336.312(V)	mm
Pixel pitch	0.3114 (H) × 0.3114(V)	mm
Number of pixels	1920(H)×1080 (V) (1 pixel = R + G + B dots)	pixels

### 10.2 Anti-Glare and Polarizer Hardness.

The surface of the LCD has an anti-glare coating to minimize reflection and a coating to reduce scratching.

### 10.3 Light Leakage

There shall not be visible light from the back-lighting system around the edges of the screen as seen from a distance 50cm from the screen with an overhead light level of 350lux.

**11.0 RELIABILITY TEST**

The Reliability test items and its conditions are shown in below.

<Table 9 Reliability Test Parameters >

No	Test Items	Conditions
1	High temperature & high humidity storage test	Ta = 60 °C, 90%RH, 240hrs
2	Low temperature storage test	Ta = -20 °C, 240 hrs
3	High temperature & high humidity operation test	Ta = 50 °C, 80%RH, 240hrs
4	High temperature operation test	Ta = 60 °C, 240hrs
5	Low temperature operation test	Ta = -5°C, 240hrs
6	Thermal shock	Ta = -20 °C ↔ 60 °C (0.5 hr), 100 cycle
7	Vibration test (non-operating)	Frequency           1 ~ 200 Hz, Gravity / AMP       1.2 Grms Period                +X, -Y, 30 min, ±Z 1Hr
8	Electro-static discharge test	Air       : 150 pF, 330Ω, ± 15 KV Contact : 150 pF, 330Ω, ± 8 KV

## 12.0 PRECAUTIONS

Please pay attention to the followings when you use this TFT LCD Module.

### 12.1 Mounting Precautions

- Use finger-stalls with soft gloves in order to keep display clean during the incoming inspection and assembly process.
- You must mount a module using specified mounting holes (Details refer to the drawings)
- You should consider the mounting structure so that uneven force (ex. Twisted stress, Concentrated stress) is not applied to the module. And the case on which a module is mounted should have sufficient strength so that external force is not transmitted directly to the module.
- Do not apply mechanical stress or static pressure on module; Abnormal display cause by pressing some parts of module during assembly process, do not belong to product failure, the press should be agreed by two sides.
- Determine the optimum mounting angle, refer to the viewing angle range in the specification for each model.
- Do not apply mechanical stress or static pressure on module, and avoid impact, vibration and falling.
- Acetic acid type and chlorine type materials for the cover case are not desirable because the former generates corrosive gas of attacking the polarizer at high temperature and the latter causes circuit break by electro-chemical reaction.
- Protection film for polarizer on the module should be slowly peeled off before display.
- Be careful to prevent water & chemicals contact the module surface.
- You should adopt radiation structure to satisfy the temperature specification.
- Do not touch, push or rub the exposed polarizers with glass, tweezers or anything harder than HB pencil lead. And please do not rub with dust clothes with chemical treatment. Do not touch the surface of polarizer for bare hand or greasy cloth. (Some cosmetics are detrimental to the polarizer.)
- When the surface becomes dusty, please wipe gently with absorbent cotton or other soft materials like chamois soaks with petroleum benzine. Normal-hexane & alcohol is recommended for cleaning the adhesives used to attach front / rear polarizers. Do not use acetone, toluene, because they cause chemical damage to the polarizer.
- Wipe off saliva or water drops as soon as possible. Their long time contact with polarizer causes deformations and color fading..

- This module has its circuitry PCB's on the rear side and Driver IC, should be handled carefully in order not to be stressed.
- Avoid impose stress on PCB and Driver IC during assembly process ,Do not drawing, bending, COF package & wire
- Do not disassemble the module.

## 12.2 Operating Precautions

- Do not connector or disconnect the cable to/from the Module at the "Power On" Condition.
- When the module is operating, do not lose CLK, ENAB signals. If any one of these signals is lost, the module would be damaged.
- Obey the supply voltage sequence. If wrong sequence is applied, the module would be damaged.
- Do not allow to adjust the adjustable resistance or switch
- The electrochemical reaction caused by DC voltage will lead to LCD module degradation, so DC drive should be avoided.
- The LCD modules use C-MOS LSI drivers, so customers are recommended that any unused input terminal would be connected to Vdd or Vss, do not input any signals before power is turn on, and ground you body, work/assembly area, assembly equipment to protect against static electricity.
- Do not exceed the absolute maximum rating value. (supply voltage variation, input voltage variation, variation in part contents and environmental temperature, and so on) Otherwise the Module may be damaged.
- Module has high frequency circuits. Sufficient suppression to the electromagnetic interference shall be done by system manufacturers. Grounding and shielding methods may be important to minimized the interference.
- Design the length of cable to connect between the connector for back-light and the converter as shorter as possible and the shorter cable shall be connected directly , The long cable between back-light and Converter may cause the Luminance of LED to lower and need a higher startup voltage
- The cables should be as short as possible between System Board and PCB interface.
- Connectors are precision devices to transmit electrical signals, and operators should plug in parallel
- Be careful for condensation at sudden temperature change. Condensation makes damage to polarizer or electrical contacted parts. And after fading condensation, smear or spot will occur.

### 12.3 Electrostatic Discharge Precautions

- Avoid the use work clothing made of synthetic fibers. We recommend cotton clothing or other conductivity-treated fibers.
- Since a module is composed of electronic circuits, it is not strong to electrostatic discharge. Make certain that treatment persons are connected to ground through wrist band etc.
- Do not close to static electricity to avoid product damage.
- Do not touch interface pin directly.

### 12.4 Precautions for Strong Light Exposure

- Do not leave the module operation or storage in Strong light . Strong light exposure causes degradation of polarizer and color filter.

### 12.5 Precautions for Storage

#### A. Atmosphere Requirement

ITEM	UNIT	MIN	MAX
Storage Temperature	(°C)	5	40
Storage Humidity	(%rH)	40	75
Storage Life	6 months		
Storage Condition	<ul style="list-style-type: none"> <li>• The storage room should be equipped with a dark and good ventilation facility.</li> <li>• Prevent products from being exposed to the direct sunlight, moisture and water.</li> <li>• The product need to keep away from organic solvent and corrosive gas.</li> <li>• Be careful for condensation at sudden temperature change.</li> <li>• Storage condition is guaranteed under packing conditions.</li> </ul>		

#### B. Package Requirement

- The product should be placed in a sealed polythene bag.
- Product Should be placed on the pallet, Which is away from the floor, Be cautions not to pile the product up.
- The polarizer surface should not come in contact with any other object. It is recommended that they be stored in the container in which they were shipped.
- As the original protective film, do not use the adhesive protective film to avoid change of Pol color and characteristic.

## 12.6 Precautions for protection film

- Remove the protective film slowly, keeping the removing direction approximate 30-degree not vertical from panel surface, If possible, under ESD control device like ion blower, and the humidity of working room should be kept over 50%RH to reduce the risk of static charge.
- People who peeled off the protection film should wear anti-static strap and grounded well.

## 12.7 Appropriate Condition for Commercial Display

-Generally large-sized LCD modules are designed for consumer applications . Accordingly, long-term display like in Commercial Display application, can cause uneven display including image sticking. To optimize module's lifetime and function, several operating usages are required.

### 1. Normal operating condition

- Temperature:  $20 \pm 15^{\circ}\text{C}$
- Operating Ambient Humidity :  $55 \pm 20\%$
- Display pattern: dynamic pattern (Real display)
- Well-ventilated place is recommended to set up Commercial Display system

### 2. Special operating condition

#### a. Ambient condition

- Well-ventilated place is recommended to set up Commercial Display system.

#### b. Power and screen save

- Periodical power-off or screen save is needed after long-term display.

c. As the low temperature, the response time is greatly delayed. As the high temperatures (higher than the operating temperature) the LCD module may turn black screen. The above phenomenon cannot explain the failure of the display. When the temperature returns to the normal operating temperature, the LCD module will return to normal display.

d. When expose to drastic fluctuation of temperature (hot to cold or cold to hot) ,the LCD module may be affected; Specifically, drastic temperature fluctuation from cold to hot ,produces dew on the LCD module 's surface which may affect the operation of the polarizer and LCD module

e. Do not exceed the absolute maximum rating value. (supply voltage variation, input voltage variation, variation in part contents and environmental temperature, and so on) Otherwise the Module may be damaged.

f. Products exposed to low temperature environment for a long time, need to carry out necessary protection , low temperature environment is usually refrigerators , vending machine Etc...

g. Long time and large angle forward use or unconventional use , It is strongly recommended to contact BOE for filed application engineering advice

h. Product reliability and functions are only guaranteed when the product is used under right operation usages. If product will be used in extreme conditions such as high temperature, high humidity, high altitude, special display images, running time, long time operation, outdoor operation, etc. It is strongly recommended to contact BOE for filed application engineering advice. Otherwise, its reliability and function may not be guaranteed. Extreme conditions are commonly found at airports, transit stations, banks, stock market and controlling systems.

3. Operating usages to protect against image sticking due to long-term static display.

a. Suitable operating time: under 20 hours a day.

b. Static information display recommended to use with moving image.

- Cycling display between 5 minutes' information(static) display and 10 seconds' moving image.

c. Background and character (image) color change

- Use different colors for background and character, respectively.

- Change colors themselves periodically.

d. Avoid combination of background and character with large different luminance.

1) Abnormal condition just means conditions except normal condition.

2) Black image or moving image is strongly recommended as a screen save

4. Lifetime in this spec. is guaranteed only when Commercial Display is used according to operating usages.

5. Module should be turned clockwise based on front view when used in portrait mode.

## 12.8 Other Precautions

### A. LC Leak

- If the liquid crystal material leaks from the panel, it is recommended to wash the LC with acetone or ethanol and then burn it.
- If the liquid crystal material leaks from the panel, it should be kept away from the eyes or mouth. In case of contact with hands, skin or clothes, it has to be washed away thoroughly with soap.
- If LC in mouth, mouth need to be washed, drink plenty of water to induce vomiting and follow medical advice.
- If LC touch eyes, eyes need to be washed with running water at least 15 minutes.

### B. Rework

- When returning the module for repair or etc., Please pack the module not to be broken. We recommend to use the original shipping packages.

### 13.0 PRODUCT SERIAL NUMBER

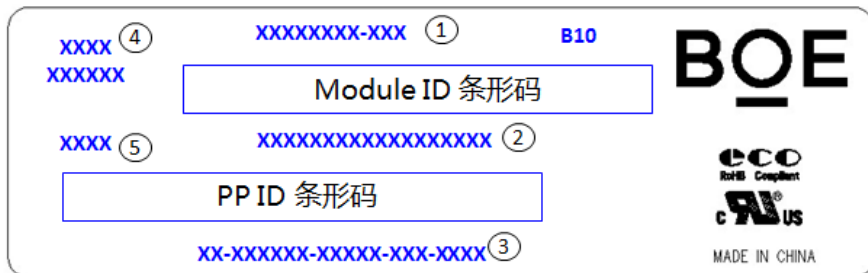

- ① FG-CODE
- ② Module ID, 最后一位为Revision Code (扫描不显示), 前17位编码规则如下
- ③ PPID (客户端ID)
- ④ D/PN码, 规格待确定
- ⑤ 生产年份+生产周别 (中间无空格)

#### MDL ID Naming Rule:

Digit	1	2	3	4	5	6	7	8	9	10	11	12	13	14	15	16	17
Code	S	L	S	A	1	0	8	5	9	4	2	0	0	0	1	D	B
Description	Product Code/GBN→FG-CODE—一对应		Grade	line	Year	Month	Model Extension Code (Last 4 Digits of FG-CODE)				Serial No. Hex-Decimal 000000-FFFFFF						

### 14.0 Packing

#### 14.1 Packing Order

#### 10.1 Packing Order

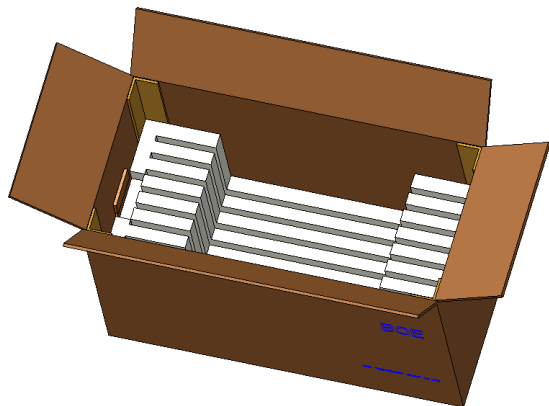

Put each module into a PE bag.  
Insert 8 Pcs MDL into each box

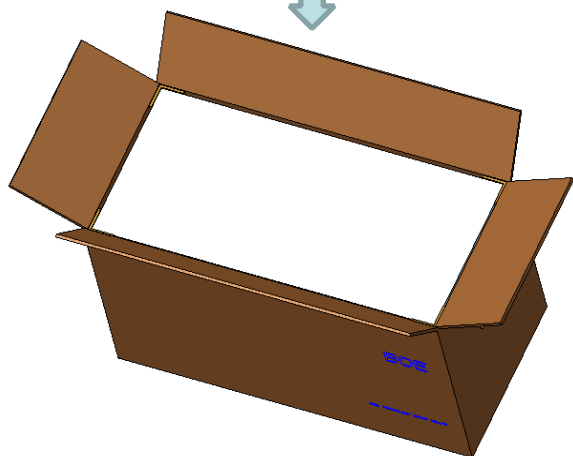
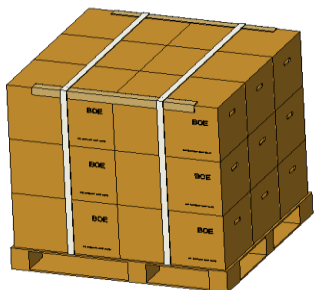
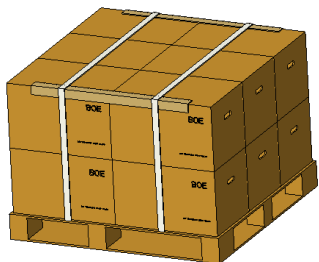
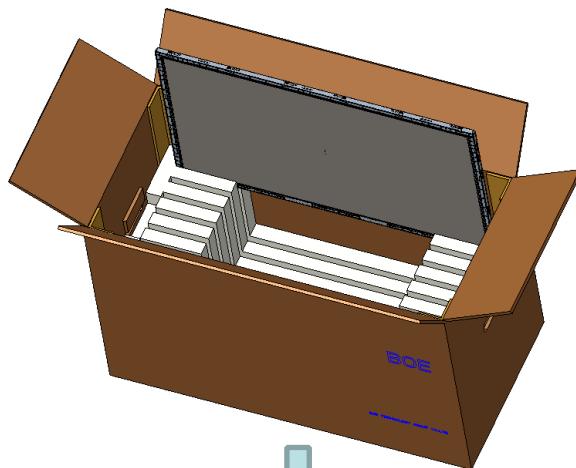

Put 1 EPE cover in and seal the box.

- Put the boxes on the Pallet
- 12boxes/Pallet:6boxes per layer, total 2 layers
- 18boxes/Pallet:6Boxes per layer, total 3 layers
- Place paper corners and wrap film around the boxes
- Pack with 2 packing belts

### 14.2 Packing Note

Box Dimension :618mm(L) 351mm(W) 394mm(H)

Package Quantity in one Box : 8pcs

### 14.3 Box label

- Label Size : 100 mm (L) 50 mm (W)

- Contents

Model : DV270FHM-N11

Q`ty : 8 Q`ty in one box

Serial No. : Box Serial No. See next page for detail description.

Date : Packing Date

FG Code : FG Code of Product

**BOE** FUZHOU BOE OPTOELECTRONICS TECHNOLOGY Co.,LTD

MODEL: XXXXXXXXX-XXX Q'TY: XXX

SERIAL NO: XXXXXXXXXXXXXXXX DATE: XXXX.XX.XX

XXXXXXXXXXXXXXXXXXXX XXXXXX

ECO RoHS Compliant

RoHS Mark

Internal CODE

Digit	1	2	3	4	5	6	7	8	9	10	11	12	13
Code													
Description	Products GBN		Grade	Line	Year		Month	Revision Code	Serial No				

## 15.0 APPENDIX

**Figure 1. Measurement Set Up**

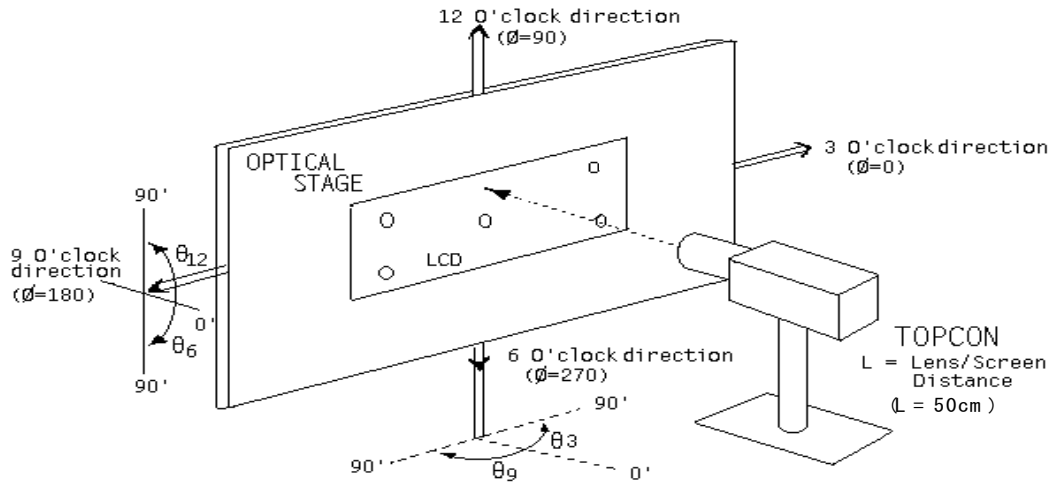

**Figure 2. White Luminance and Uniformity Measurement Locations (13 points)**

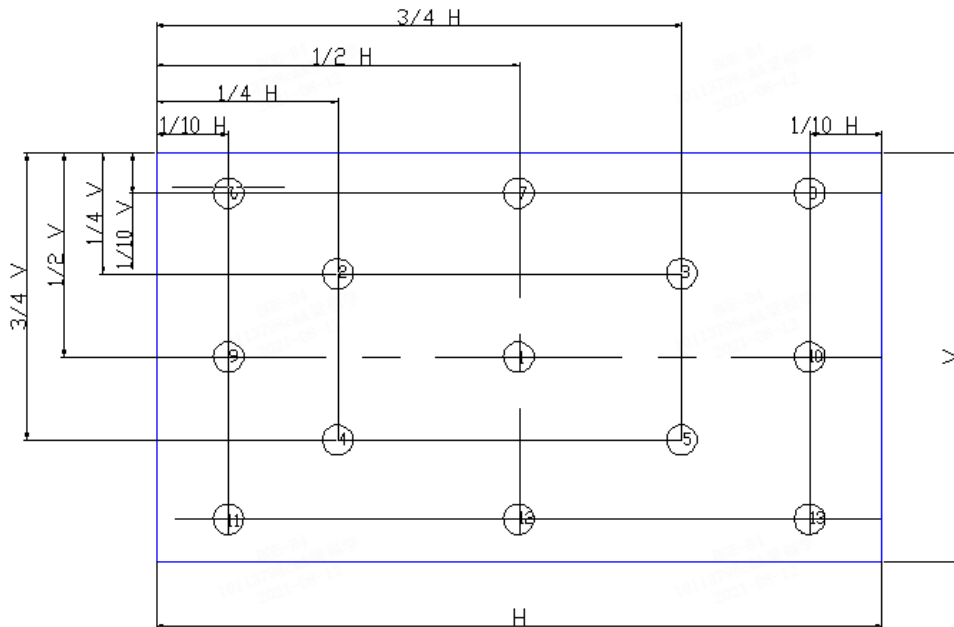

### Figure 3. Response Time Testing



### Figure 4. Cross Modulation Test Description

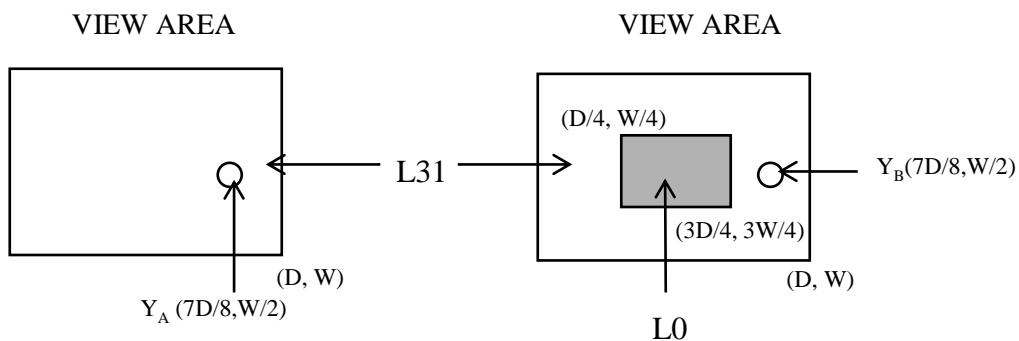

$$\text{Cross-Talk (\%)} = \left| \frac{Y_B - Y_A}{Y_A} \right| \times 100$$

Where:  $Y_A$  = Initial luminance of measured area (cd/m<sup>2</sup>)  
 $Y_B$  = Subsequent luminance of measured area (cd/m<sup>2</sup>)  
 The location measured will be exactly the same in both patterns

**Figure 5. TFT-LCD Module Outline Dimensions (Front view)**

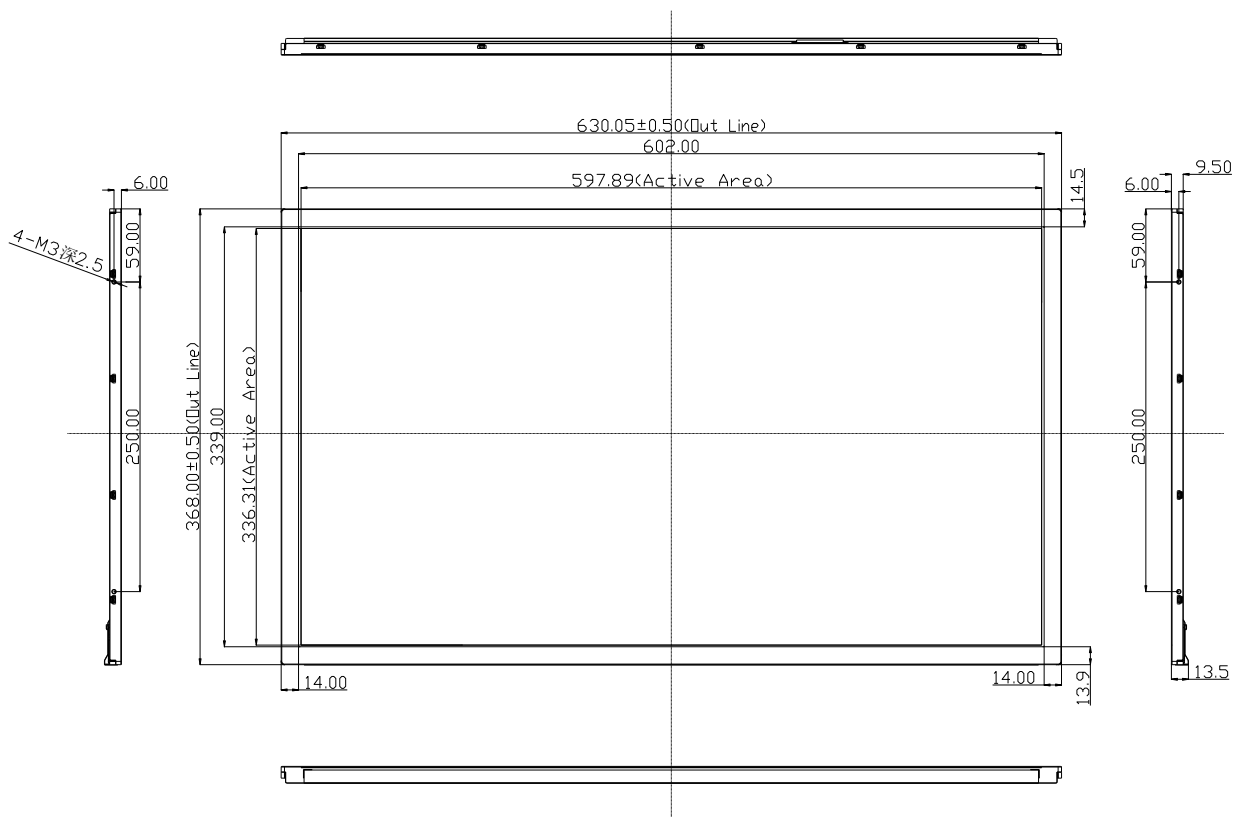

**Figure 5. TFT-LCD Module Outline Dimensions (Rear view, Horizontal placement)**

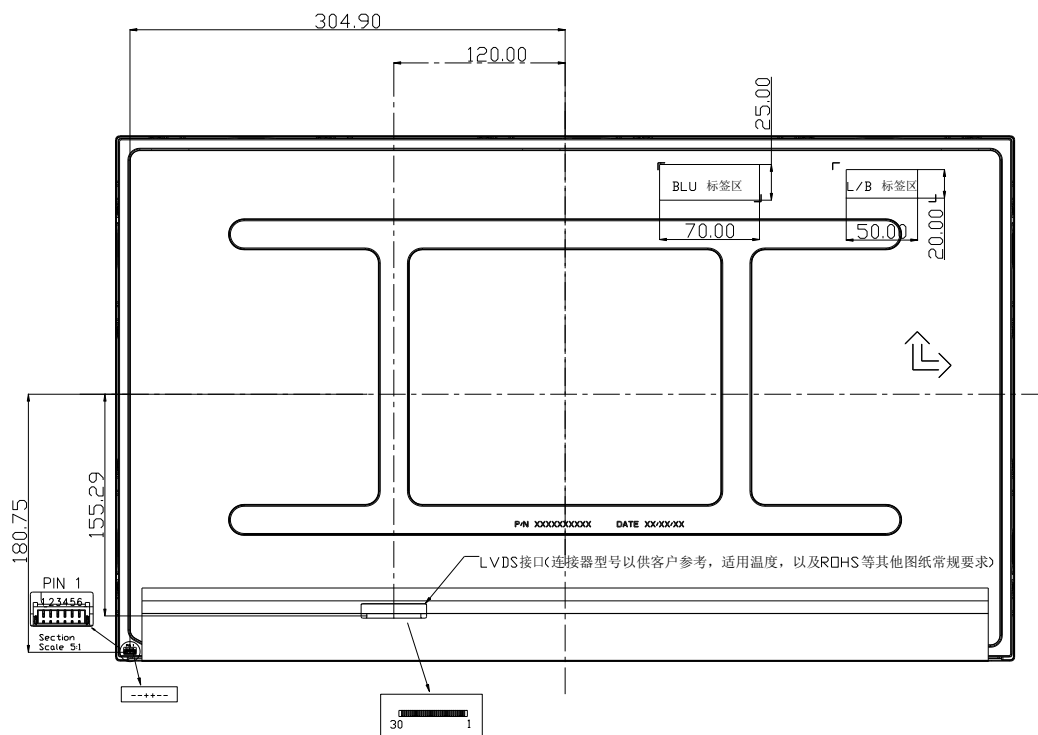

Notes:

CNT : A1009AWRR-06-H