

SPECIFICATIONS

CUSTOMER	:	
SAMPLE CODE	:	SH720128T005-ZBC
MASS PRODUCTION CODE	:	PH720128T005-ZBC
SAMPLE VERSION	:	01
SPECIFICATIONS EDITION	:	002
DRAWING NO. (Ver.)	:	LMD- PH720128T005-ZBC (Ver.002)
PACKAGING NO. (Ver.)	:	PKG- PH720128T005-ZBC (Ver.001)

Customer Approved

Date:

Approved	Checked	Designer
黃秋源 Oliver Huang	石建莊 Stone Shin	劉俊毅 Terry Liu

- Preliminary specification for design input
- Specification for sample approval

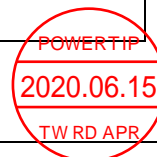

POWER TIP TECH. CORP.

Headquarters:

No.8, 6th Road, Taichung Industrial Park,
 Taichung, Taiwan
 台中市 407 工業區六路 8 號

TEL: 886-4-2355-8168
 FAX: 886-4-2355-8166

E-mail: sales@powertip.com.tw
 Http://www.powertip.com.tw



History of Version

Date <small>(mm / dd / yyyy)</small>	Ver.	Edi.	Description	Page	Design by
05/06/2019	01	001	New Drawing.	-	Terry
06/12/2020	01	002	New Sample	-	Terry
				-	

Contents

1. SPECIFICATIONS

- 1.1 Features
- 1.2 Mechanical Specifications
- 1.3 Absolute Maximum Ratings
- 1.4 DC Electrical Characteristics
- 1.5 Optical Characteristics
- 1.6 Backlight Characteristics
- 1.7 Touch Panel Characteristics

2. MODULE STRUCTURE

- 2.1 Counter Drawing
- 2.2 Interface Pin Description
- 2.3 AC Characteristics
- 2.4 Refer Initial Code

3. QUALITY ASSURANCE SYSTEM

- 3.1 Quality Assurance Flow Chart
- 3.2 Inspection Specification

4. RELIABILITY TEST

- 4.1 Reliability Test Condition

5. PRECAUTION RELATING PRODUCT HANDLING

- 5.1 Safety
- 5.2 Handling
- 5.3 Storage
- 5.4 Terms of Warranty

Appendix : LCM Drawing.
PKG Drawing

1. SPECIFICATIONS

1.1 Features

Item	Standard Value
Display Type	720 * (RGB) * 1280
LCD Type	Full Viewing Angle, Normally Black , Transmissive type
Touch panel	True Multi-Touch Capacitive Touch Panel True Multi-touch with up to 10 Points of Absolution
Screen size(Inch)	7.0 Inch
Backlight Type	LED B/L
Weight	170
Control IC	ILI9881C (TFT Unit)
Interface	MIPI Interface (TFT Unit)
ROHS	THIS PRODUCT CONFORMS THE ROHS OF PTC Detail information please refer website : http://www.powertip.com.tw/news_detail.php?Key=1&clD=1

1.2 Mechanical Specifications

Item	Standard Value	Unit
Outline Dimension	120.24 (W) * 189.32 (L) * 5.31(H)	mm
Viewing Area	87.74 (W) * 155.36 (L)	mm
Active Area	86.94 (W) * 154.56 (L)	mm

Note : For detailed information please refer to LCM drawing.

1.3 Absolute Maximum Ratings

Item	Symbol	Condition	Min.	Max.	Unit	Remark
Supply Voltage	VDD	GND=0	-0.3	+3.8	V	-
	VCI		-0.3	+7.0	V	
Operating Temperature	T _{OP}	-	-20	+70	°C	
Storage Temperature	T _{ST}	-	-30	+80	°C	

1.4 DC Electrical Characteristics

GND = 0V, Ta = 25°C

Item	Symbol	Min.	Typ.	Max.	Unit	Remark
Supply Voltage	VDD	3.0	3.3	3.6	V	Note2
	VCI	3.0	3.3	3.6		
Input signal Voltage	V _{IH}	0.7*VDD	-	VDD		
	V _{IL}	-0.3	-	0.3*VDD		
	V _{OH}	0.8*VDD	-	VDD		
	V _{OL}	0	-	0.2*VDD		
Supply Current	I _{VDD}	-	20mA	35mA		
	I _{VCI}	-	25mA	50mA		Note1

Note1: Maximum current display.

Note2 :For DSI DC level please refer to driver IC ILI9881C Specifications

1.5 Optical Characteristics

VDD= 3.3 V, Ta=25°C

Item	Symbol	Condition	Min.	Typ.	Max.	unit	
Response time	Tr +Tf	Ta = 25°C θX, θY = 0°	-	35	40	ms	Note 2
Viewing angle	Top	θY+	-	80	-	Deg.	Note 4
	Bottom	θY-	-	80	-		
	Left	θX-	-	80	-		
	Right	θX+	-	80	-		
Contrast ratio	CR		650	800	-		Note 3
Color of CIE Coordinate (With B/L & touch panel)	White	X	0.300	0.305	0.310	-	Note1
		Y	0.350	0.355	0.360		
	Red	X	0.640	0.645	0.650		
		Y	0.327	0.332	0.337		
	Green	X	0.303	0.308	0.313		
		Y	0.611	0.616	0.621		
	Blue	X	0.127	0.132	0.137		
		Y	0.050	0.055	0.060		
Average Brightness Pattern=white display (With B/L & touch panel) *2	IV	IF=90mA	430	500	-	cd/m ²	Note1
Uniformity (With B/L & touch panel) *1	△B		70	-	-	%	Note1

Note 1:

*1 : $\Delta B = B(\text{min}) / B(\text{max}) * 100\%$

*2 : Measurement Condition for Optical Characteristics:

- a : Environment: $25^{\circ}\text{C} \pm 5^{\circ}\text{C}$ / $60 \pm 20\% \text{R.H}$, no wind , dark room below 10 Lux at typical lamp current and typical operating frequency.
- b : Measurement Distance: $500 \pm 50 \text{ mm}$, ($\theta = 0^{\circ}$)
- c : Equipment: TOPCON BM-7 fast , (field 1°) , after 10 minutes operation.
- d : The uncertainty of the C.I.E coordinate measurement ± 0.01 , Average Brightness $\pm 4\%$

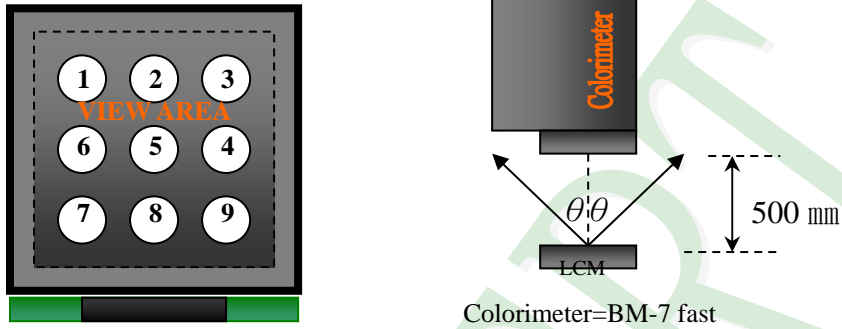

To be measured at the center area of panel with a viewing cone of 1° by Topcon luminance meter BM-7, after 10 minutes operation (module)

Note2: Definition of response time:

The output signals of photo detector are measured when the input signals are changed from "black" to "white"(falling time) and from "white" to "black"(rising time), respectively. The response time is defined as the time interval between the 10% and 90% of Amplitudes.

Refer to figure as below:

Normally White



Normally Black

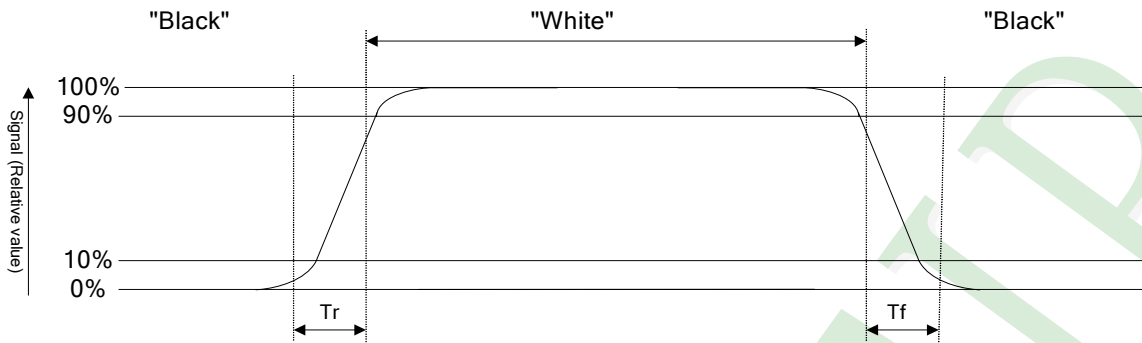

Note3: Definition of contrast ratio:

Contrast ratio is calculated with the following formula

$$\text{Contrast ratio (CR)} = \frac{\text{Photo detector output when LCD is at "White" state}}{\text{Photo detector output when LCD is at "Black" state}}$$

Note4: Definition of viewing angle:

Refer to figure as below:

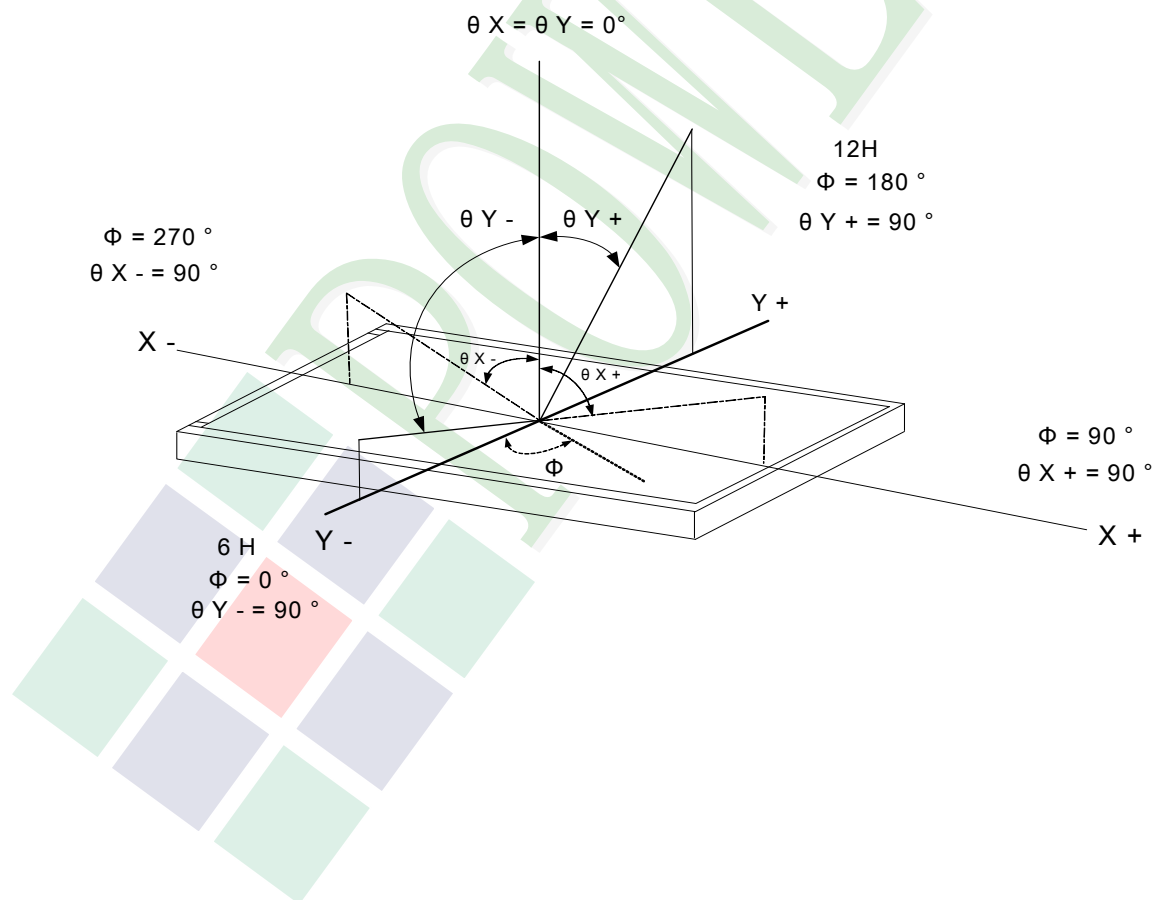

1.6 Backlight Characteristics

Electrical / Optical Characteristics

Item	Symbol	Min.	Typ.	Max.	Unit	Remark
Forward Voltage	V_f	16.2	19.2	21.0	V	Ta=25°C IF=90mA
Life time	-	20000	-	-	Hr	

LED Backlight Circuit:

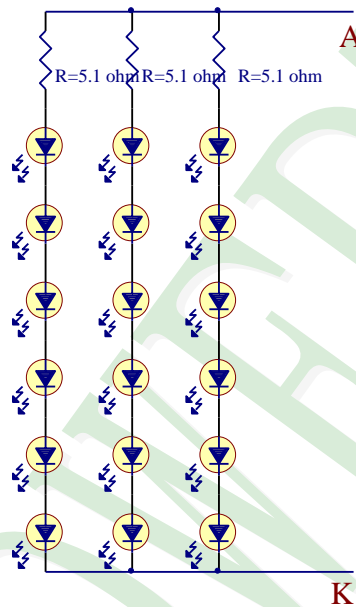

1.7 Touch Panel Characteristics

Item	Standard Value
Touch Panel Size	7"
Touch type	Projective Capacitive Touch Panel
Input Method	True Multi-touch with up to 10 Points of Absolution X and Y Coordinates
IC	FT5426
Output Interface	I2C
I2C Address	0X70

I²C Address

Bit 7	Bit 6	Bit 5	Bit 4	Bit 3	Bit 2	Bit 1	Bit 0
1	1	1	0	0	0	0	R/W

Bit 0: 0 for Write / 1 for Read

Mechanical Specifications

Item	Standard Value	Unit
Viewing Area	87.74 (W) * 155.36 (L)	mm
Number of sensing channel	25(TX) * 15 (RX)	

Absolute Maximum Ratings

Item	Symbol	Condition	Min.	Max.	Unit
Supply voltage	TPVDD	-	2.7	+3.6	V
Operating Temperature	T _{OP}	-	-20	+70	°C
Storage Temperature	T _{ST}	-	-30	+80	°C

DC Electrical Characteristics

Item	Symbol	Condition	Min.	Typ.	Max.	Unit
Power Supply Voltage	TPVDD	Ta=25°C	2.7	3.3	3.6	V
Input High Voltage	VIH		0.7 * TPVDD	-	TPVDD	V
Input Low Voltage	VIL		-0.3	-	0.3* TPVDD	V

I²C Read/Write Interface description

Write N bytes to I2C slave

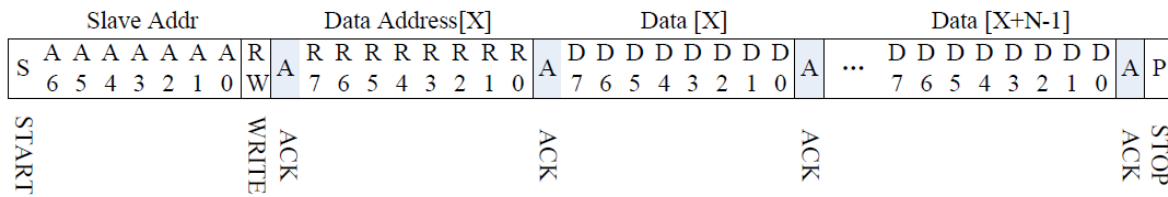

Set Data Address

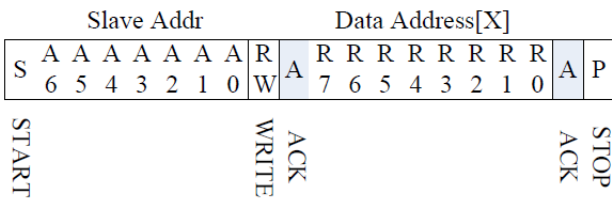

Read X bytes from I2C Slave

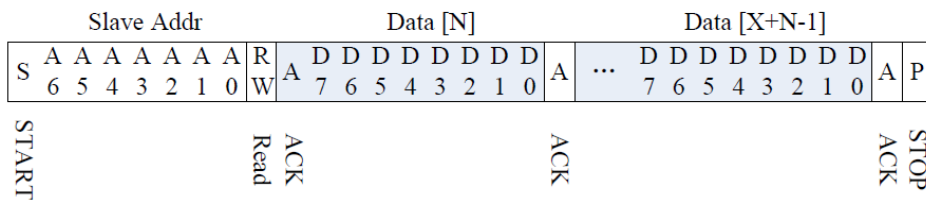

Mnemonics Description

Mnemonics	Description
S	I2C Start or I2C Restart
A[6:0]	Slave address A[6:0]:0111000b
R/ W	'1' for read, '0' for write
A(N)	ACK(NACK)
P	STOP: the indication of the end of a packet (if this bit is missing, S will indicate the end of the current packet and the beginning of the next packet)

Timing Characteristics

Parameter	Unit	Min	Max
SCL frequency	KHz	0	400
Bus free time between a STOP and START condition	us	4.7	\
Hold time (repeated) START condition	us	4.0	\
Data setup time	ns	250	\
Setup time for a repeated START condition	us	4.7	\
Setup Time for STOP condition	us	4.0	\

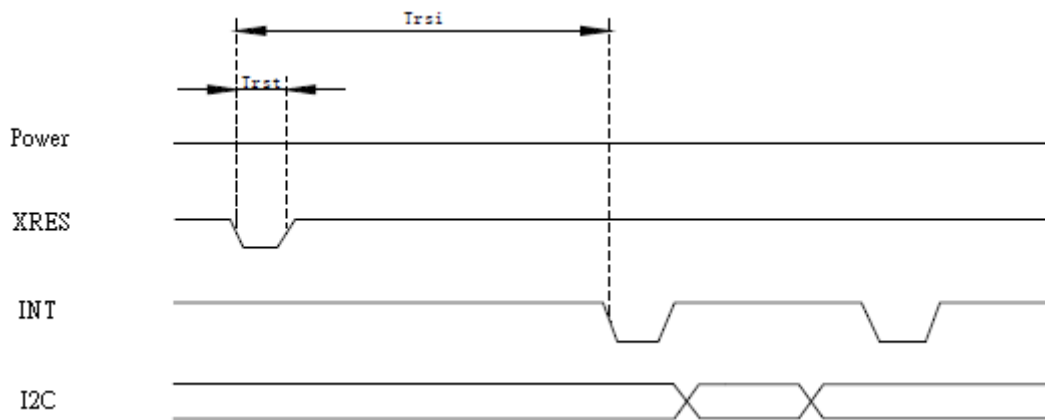
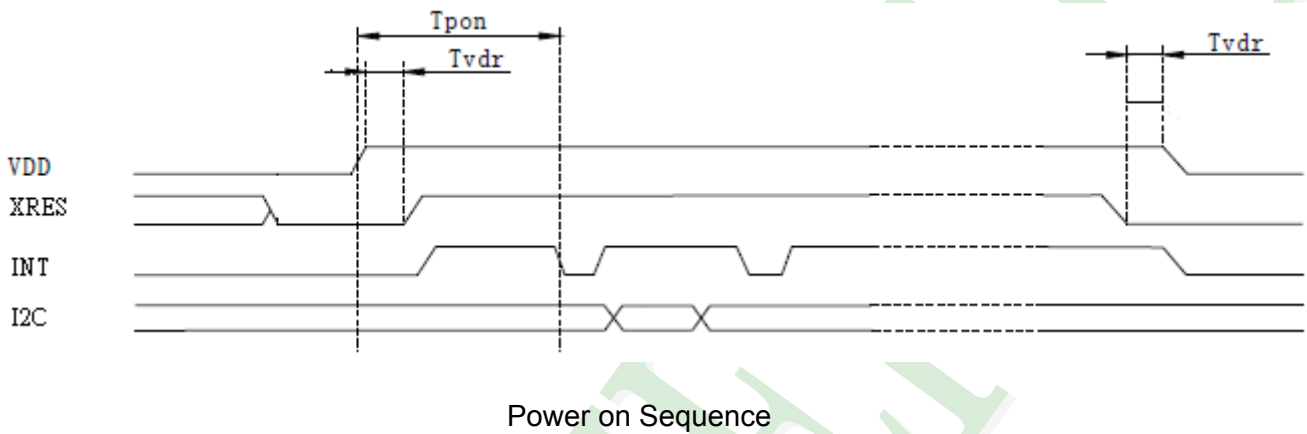
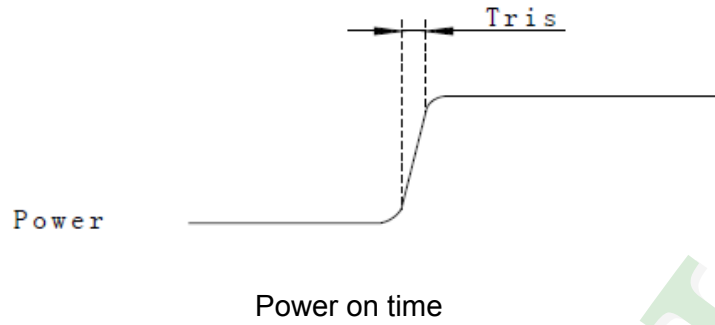

Power on / Reset Sequence Parameters

Parameter	Description	Min	Max	Units
Tris	Rise time from 0.1VDD to 0.9VDD	--	5	ms
Tpon	Time of starting to report point after powering on	200	--	ms
Tvdr	Reset time after VDD powering on	1	--	ms
Trsi	Time of starting to report point after resetting	200	--	ms
Trst	Reset time	1	--	ms

Interrupt signal from CTP to Host

As for standard CTP, host need to use both interrupt control signal and serial data interface to get the touch data. There are two kind of method to use interrupt: interrupt trigger and interrupt query.

Here is the timing to get touch data.

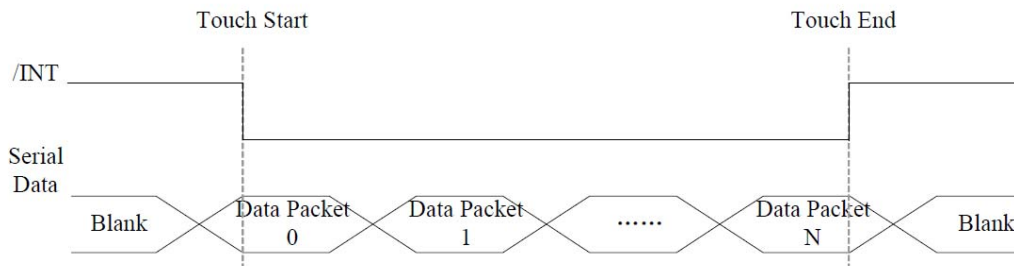

Interrupt query mode

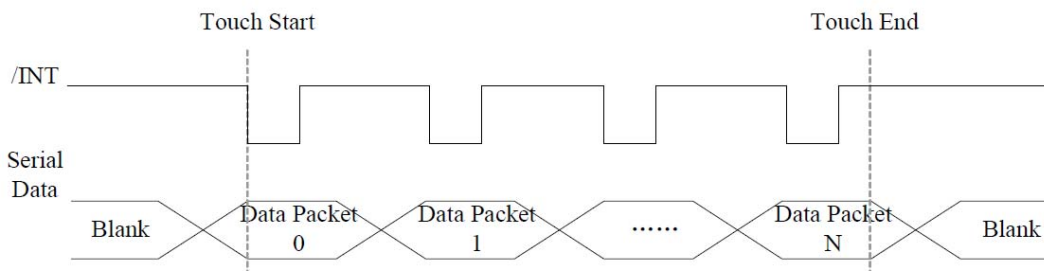

Interrupt trigger mode

Host use general I2C protocol to read the touch data or the information from CTP . CTP will send host a interrupt signal when there is a valid touch. Then host can use the serial data interface to get the touch data. If there is no valid touch detected, the $\overline{\text{INT}}$ will not be pulled up, the host do not need to read the touch data.

NOTE: “valid touch” may have different definition in various systems. For example, in some systems, the valid touch is defined as there is one more valid touch point. But in some other systems, the valid touch is defined as one more valid touch with valid gestures. In usual, $\overline{\text{INT}}$ will be pulled up when there is a valid touch point, and to be low when a touch finishes.

As for interrupt trigger mode, $\overline{\text{INT}}$ signal will be low if there is a touch detected. But for per update of valid touch data, CTP will produce a valid pulse for $\overline{\text{INT}}$ signal, host can read the touch data periodically according to the frequency of this pulse. In this mode, the pulse frequency is the touch data update frequency.

CTP Register Mapping

Address	Name	Bit7	Bit6	Bit5	Bit4	Bit3	Bit2	Bit1	Bit0	Host Access	
00h	DEVIDE_MODE	-	Device Mode[2:0]			-	-	-	-	WR	
01h	GEST_ID	Gesture ID[7:0]								R	
02h	TD_STATUS	-	-	-	-	Number of touch points[3:0]				R	
03h	TOUCH1_XH	1st Event Flag		-	-	1st Touch X Position[11:8]				R	
04h	TOUCH1_XL	1st Touch X Position[7:0]								R	
05h	TOUCH1_YH	1st Touch ID[3:0]			1st Touch Y Position[11:8]						R
06h	TOUCH1_YL	1st Touch Y Position[7:0]								R	
07h	-	-								R	
08h	-	-								R	
09h	TOUCH2_XH	2st Event Flag	-	-	2st Touch X Position[11:8]					R	
0Ah	TOUCH2_XL	2st Touch X Position[7:0]								R	
0Bh	TOUCH2_YH	2st Touch ID[3:0]			2st Touch Y Position[11:8]						R
0Ch	TOUCH2_YL	2st Touch Y Position[7:0]								R	
0Dh	-	-								R	
0Eh	-	-								R	
0Fh	TOUCH3_XH	3st Event Flag	-	-	3st Touch X Position[11:8]					R	
10h	TOUCH3_XL	3st Touch X Position[7:0]								R	
11h	TOUCH3_YH	3st Touch ID[3:0]			3st Touch Y Position[11:8]						R
12h	TOUCH3_YL	3st Touch Y Position[7:0]								R	
13h	-	-								R	
14h	-	-								R	
15h	TOUCH4_XH	4st Event Flag	-	-	4st Touch X Position[11:8]					R	
16h	TOUCH4_XL	4st Touch X Position[7:0]								R	
17h	TOUCH4_YH	4st Touch ID[3:0]			4st Touch Y Position[11:8]						R
18h	TOUCH4_YL	4st Touch Y Position[7:0]								R	
19h	-	-								R	
1Ah	-	-								R	
1Bh	TOUCH5_XH	5st Event Flag	-	-	5st Touch X Position[11:8]					R	
1Ch	TOUCH5_XL	5st Touch X Position[7:0]								R	
1Dh	TOUCH5_YH	5st Touch ID[3:0]			5st Touch Y Position[11:8]						R
1Eh	TOUCH5_YL	5st Touch Y Position[7:0]								R	
1Fh	-	-								R	
20h	-	-								R	

Address	Name	Bit7	Bit6	Bit5	Bit4	Bit3	Bit2	Bit1	Bit0	Host Access
21h	TOUCH6_XH	6st Event Flag		-	-	6st Touch X Position[11:8]				R
22h	TOUCH6_XL	6st Touch X Position[7:0]								R
23h	TOUCH6_YH	6st Touch ID[3:0]			6st Touch Y Position[11:8]					R
24h	TOUCH6_YL	6st Touch Y Position[7:0]								R
25h	-	-								R
26h	-	-								R
27h	TOUCH7_XH	7st Event Flag		-	-	7st Touch X Position[11:8]				R
28h	TOUCH7_XL	7st Touch X Position[7:0]								R
29h	TOUCH7_YH	7st Touch ID[3:0]			7st Touch Y Position[11:8]					R
2ah	TOUCH7_YL	7st Touch Y Position[7:0]								R
2bh	-	-								R
2ch	-	-								R
2dh	TOUCH8_XH	8st Event Flag		-	-	8st Touch X Position[11:8]				R
2eh	TOUCH8_XL	8st Touch X Position[7:0]								R
2fh	TOUCH8_YH	8st Touch ID[3:0]			8st Touch Y Position[11:8]					R
30h	TOUCH8_YL	8st Touch Y Position[7:0]								R
31h	-	-								R
32h	-	-								R
33h	TOUCH9_XH	9st Event Flag		-	-	9st Touch X Position[11:8]				R
34h	TOUCH9_XL	9st Touch X Position[7:0]								R
35h	TOUCH9_YH	9st Touch ID[3:0]			9st Touch Y Position[11:8]					R
36h	TOUCH9_YL	9st Touch Y Position[7:0]								R
37h	-	-								R
38h	-	-								R
39h	TOUCH10_XH	10st Event Flag		-	-	10st Touch X Position[11:8]				R
3ah	TOUCH10_XL	10st Touch X Position[7:0]								R
3bh	TOUCH10_YH	10st Touch ID[3:0]			10st Touch Y Position[11:8]					R
3ch	TOUCH10_YL	10st Touch Y Position[7:0]								R
3dh	-	-								R
3eh	-	-								R
3fh	-	-								R

DEVICE_MODE

This register is the device mode register, configure it to determine the current mode of the chip.

Address	Bit Address	Register Name	Description
00h	6 : 4	Device Mode [2:0]	000b Work Mode 100b Factory Mode – read raw data

GEST_ID

This register describes the gesture of a valid touch.

Address	Bit Address	Register Name	Description
01h	7 : 0	Gesture ID [7:0]	0x10 Move UP 0x14 Move Left 0x18 Move Down 0x1C Move Right 0x48 Zoom In 0x49 Zoom Out

TD_STATUS

This register is the Touch Data status register.

Address	Bit Address	Register Name	Description
02h	7 : 4	Reserved	
	3 : 0	Number of touch points[3:0]	How many points detected. 1-5 is valid.

TOUCHn_XH

This register describes MSB of the X coordinate of the nth touch point and the corresponding event flag.

Address	Bit Address	Register Name	Description
03h ~ 39h	7 : 6	Event Flag	00b: Put Down 01b: Put Up 10b: Contact 11b: Reserved
	5 : 4		Reserved
	3 : 0	Touch X Position [11:8]	MSB of Touch X Position in pixels

TOUCHn_XL

This register describes LSB of the X coordinate of the nth touch point

Address	Bit Address	Register Name	Description
04h ~ 3Ah	7 : 0	Touch X Position [7:0]	LSB of the Touch X Position in pixels

TOUCHn_YH

This register describes MSB of the Y coordinate of the nth touch point and corresponding touch ID.

Address	Bit Address	Register Name	Description
05h ~ 3Bh	7 : 4	Touch ID[3:0]	Touch ID of Touch Point
	3 : 0	Touch Y Position [11:8]	MSB of Touch Y Position in pixels

TOUCHn_YL

This register describes LSB of the Y coordinate of the nth touch point.

Address	Bit Address	Register Name	Description
06h ~ 3Ch	7:0	Touch Y Position[7:0]	LSB of The Touch Y Position in pixels

2. MODULE STRUCTURE

2.1 Counter Drawing

2.1.1 LCM Mechanical Diagram

* See Appendix

2.1.2 Block Diagram

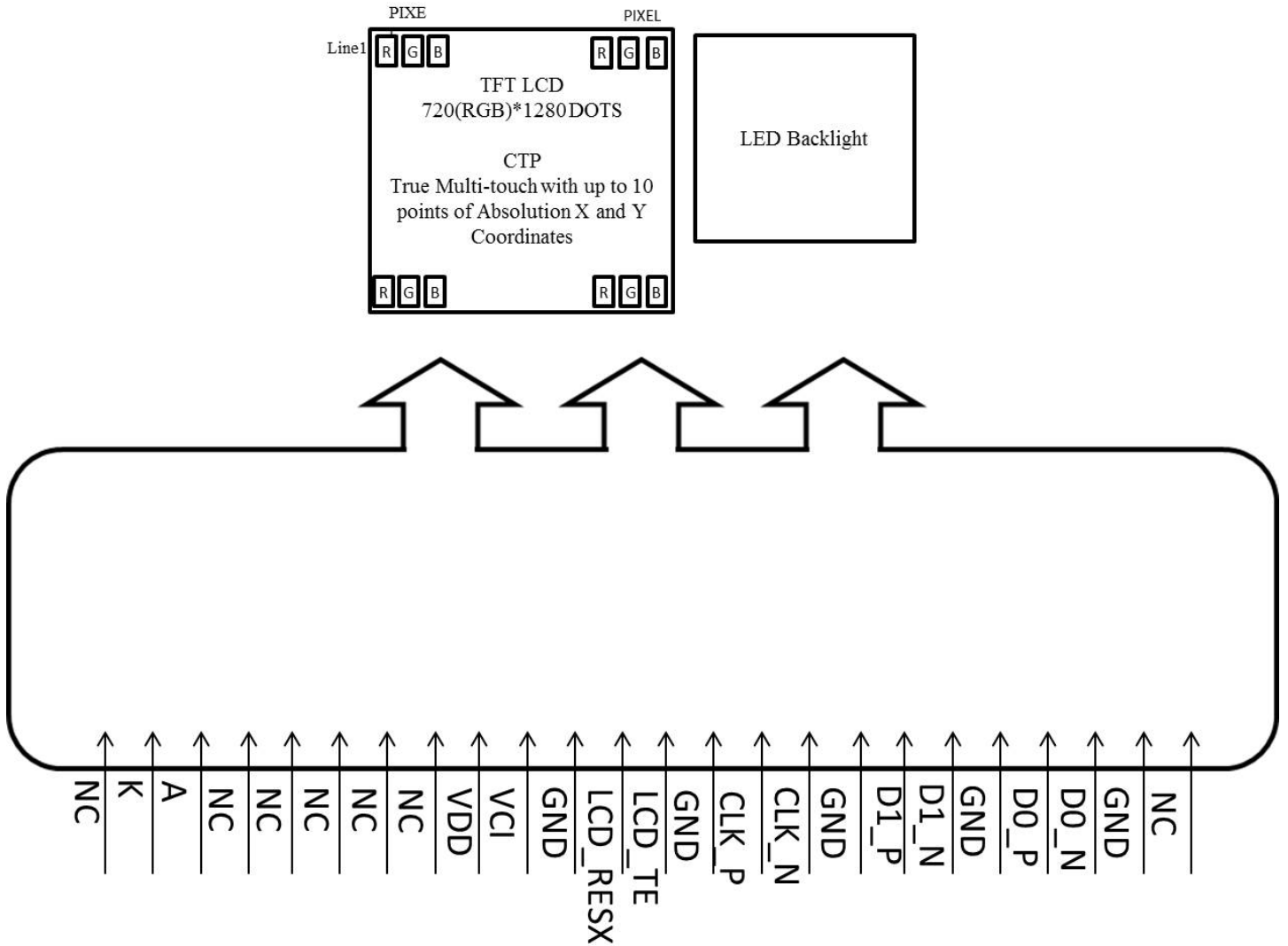

2.2 Interface Pin Description

Interface for TFT display :

Pin#	Name	DESCRIPTION
1	NC	No connection.
2	K	Power for LED backlight cathode input.
3	A	Power for LED backlight anode input.
4	NC	No connection.
5	NC	No connection.
6	GND	Ground
7	NC	No connection.
8	NC	No connection.
9	VDD	Power supply for internal logic regulator.
10	VCI	Power supply for analog circuit.
11	GND	Ground.
12	LCD_RESX	The external reset input Initializes the chip with a low input. Be sure to execute a power-on reset after supplying power.
13	LCD_TE	Tearing effect output pin.
14	GND	Ground.
15	CLK_P	MIPI DSI differential clock pair
16	CLK_N	MIPI DSI differential clock pair
17	GND	Ground.
18	D1_P	MIPI DSI differential data pair. (Data lane 1)
19	D1_N	MIPI DSI differential data pair. (Data lane 1)
20	GND	Ground.
21	D0_P	MIPI DSI differential data pair. (Data lane 0)
22	D0_N	MIPI DSI differential data pair. (Data lane 0)
23	GND	Ground.
24	NC	No connection.

Interface for CTP:

Pin#	Name	DESCRIPTION
1	RST	RESET.
2	SCL	I2C Data.
3	SDA	I2C Data.
4	INT	The interrupt from the CTP to the Host.
5	TPVDD	Power.
6	GND	Ground.

2.3 AC Electrical Characteristics

Timing for DSI video mode

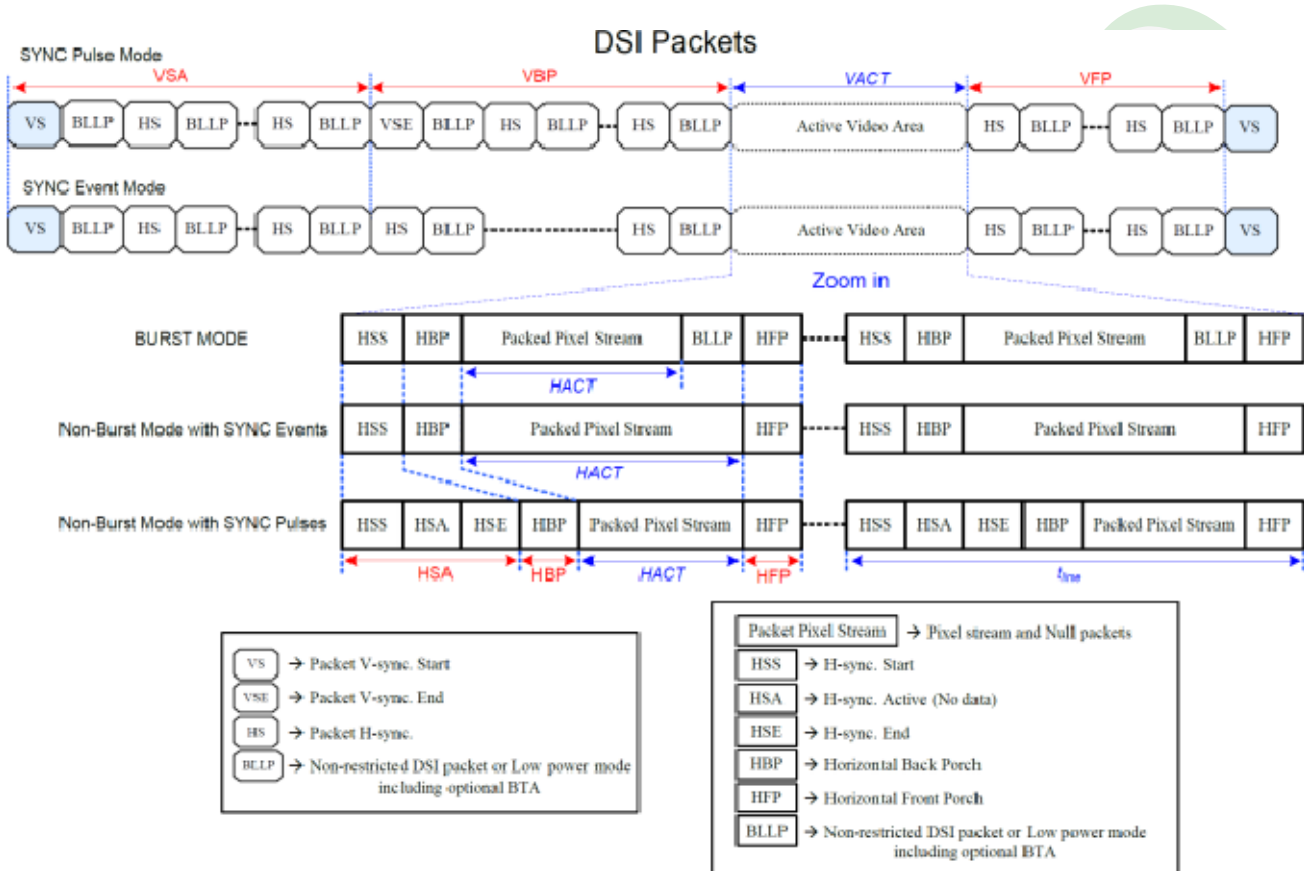

Parameters	Symbols	Min.	Typ.	Max.	Units
Vertical sync. active	VSA	2 <small>(Note 6)</small>	-	-	Line
Vertical Back Porch	VBP	14 <small>(Note 6)</small>	-	-	Line
Vertical Front Porch	VFP	8 <small>(Note 6)</small>	-	-	Line
Active lines per frame	VACT	-	1280	-	Line
Horizontal sync. active	HSA	2	-	-	Pixel
Horizontal Porch period	HSA + HBP + HFP	1.6	-	-	us
Active pixels per line	HACT	-	720	-	Pixel
Bit rate	BR _{tps}	385		Note 5	Mbps/lane

1 UI=1/Bit rate

$HSA(\text{pixel}) = (tHSA \times \text{lane number}) / (UI \times \text{pixel format})$

$HBP(\text{pixel}) = (tHBP \times \text{lane number}) / (UI \times \text{pixel format})$

$HFP(\text{pixel}) = (tHFP \times \text{lane number}) / (UI \times \text{pixel format})$

$$\text{Frame Rate} = \frac{BR_{\text{bps}} \times \text{Lane}_{\text{num}}}{(VACT+VSA+VBP+VFP) \times (HACT+HSA+HBP+HFP) \times \text{Pixel Format}}$$

Example : BR_{tps} = 457Mbps/lane, 1UI=2.1883ns, Frame rate=60Hz, VACT=1280, VSA=2, VBP=30, VFP=20, HACT=720, HSA=33, HBP=100, HFP=100, Lane_{num}=4(lane), Pixel Format=24(bit).

Note:

1. Lane_{num}: Data lane of MIPI-DSI.
2. Pixel Format: Please reference to “4.1 DSI System Interface”.
3. The formula exists slightly error because of the host-transmission way.
4. The best frame rate setting : 2 data lanes : 50~60 Hz / 3 data lanes : 50~70 Hz / 4 data lanes : 50~70 Hz.
5. Please reference to “Table 39: Limited Clock Channel Speed”.
6. The minimum values of this table mean the limitation of IC without considering the panel GIP. The actual values of VSA, VBP and VFP will be changed by different panel GIP setting.

2.4 Refer Initial Code

```
Void ILI9881C_HSD070FHW1-D_(C0700)_3H_Initial Code(Void)
```

```
{// IOVCC=1.8V //VSP=5.5 VSN=-5.5 External
```

```
//***** Reset LCD Driver *****//
```

```
LCD_nRESET = 1;
```

```
Delaysms(1); // Delay 1ms
```

```
LCD_nRESET = 0;
```

```
Delaysms(1); // Delay 1ms // This Delay time is necessary
```

```
LCD_nRESET = 1;
```

```
Delaysms(10); // Delay 120 ms
```

```
//***** Start Initial Sequence *****//
```

```
LCD_ILI9881C_CMD(0xFF);
```

```
LCD_ILI9881C_INDEX(0x98);
```

```
LCD_ILI9881C_INDEX(0x81);
```

```
LCD_ILI9881C_INDEX(0x03);
```

```
LCD_ILI9881C_CMD(0x01);
```

```
LCD_ILI9881C_INDEX(0x00);
```

```
LCD_ILI9881C_CMD(0x02);
```

```
LCD_ILI9881C_INDEX(0x00);
```

```
LCD_ILI9881C_CMD(0x03);
```

```
LCD_ILI9881C_INDEX(0x73);
```

```
LCD_ILI9881C_CMD(0x04);
```

```
LCD_ILI9881C_INDEX(0x00);
```

```
LCD_ILI9881C_CMD(0x05);
```

```
LCD_ILI9881C_INDEX(0x00);
```

```
LCD_ILI9881C_CMD(0x06);
```

```
LCD_ILI9881C_INDEX(0x0A);
```

```
LCD_ILI9881C_CMD(0x07);
```

```
LCD_ILI9881C_INDEX(0x00);
```

LCD_ILI9881C_CMD(0x08);
LCD_ILI9881C_INDEX(0x00);
LCD_ILI9881C_CMD(0x09);
LCD_ILI9881C_INDEX(0x61);
LCD_ILI9881C_CMD(0x0A);
LCD_ILI9881C_INDEX(0x00);
LCD_ILI9881C_CMD(0x0B);
LCD_ILI9881C_INDEX(0x00);
LCD_ILI9881C_CMD(0x0C);
LCD_ILI9881C_INDEX(0x01);
LCD_ILI9881C_CMD(0x0D);
LCD_ILI9881C_INDEX(0x00);
LCD_ILI9881C_CMD(0x0E);
LCD_ILI9881C_INDEX(0x00);
LCD_ILI9881C_CMD(0x0F);
LCD_ILI9881C_INDEX(0x61);
LCD_ILI9881C_CMD(0x10);
LCD_ILI9881C_INDEX(0x61);
LCD_ILI9881C_CMD(0x11);
LCD_ILI9881C_INDEX(0x00);
LCD_ILI9881C_CMD(0x12);
LCD_ILI9881C_INDEX(0x00);
LCD_ILI9881C_CMD(0x13);
LCD_ILI9881C_INDEX(0x00);
LCD_ILI9881C_CMD(0x14);
LCD_ILI9881C_INDEX(0x00);
LCD_ILI9881C_CMD(0x15);
LCD_ILI9881C_INDEX(0x00);
LCD_ILI9881C_CMD(0x16);
LCD_ILI9881C_INDEX(0x00);
LCD_ILI9881C_CMD(0x17);
LCD_ILI9881C_INDEX(0x00);
LCD_ILI9881C_CMD(0x18);
LCD_ILI9881C_INDEX(0x00);
LCD_ILI9881C_CMD(0x19);
LCD_ILI9881C_INDEX(0x00);
LCD_ILI9881C_CMD(0x1A);
LCD_ILI9881C_INDEX(0x00);
LCD_ILI9881C_CMD(0x1B);

LCD_ILI9881C_INDEX(0x00);
LCD_ILI9881C_CMD(0x1C);
LCD_ILI9881C_INDEX(0x00);
LCD_ILI9881C_CMD(0x1D);
LCD_ILI9881C_INDEX(0x00);
LCD_ILI9881C_CMD(0x1E);
LCD_ILI9881C_INDEX(0x40);
LCD_ILI9881C_CMD(0x1F);
LCD_ILI9881C_INDEX(0x80);
LCD_ILI9881C_CMD(0x20);
LCD_ILI9881C_INDEX(0x06);
LCD_ILI9881C_CMD(0x21);
LCD_ILI9881C_INDEX(0x01);
LCD_ILI9881C_CMD(0x22);
LCD_ILI9881C_INDEX(0x00);
LCD_ILI9881C_CMD(0x23);
LCD_ILI9881C_INDEX(0x00);
LCD_ILI9881C_CMD(0x24);
LCD_ILI9881C_INDEX(0x00);
LCD_ILI9881C_CMD(0x25);
LCD_ILI9881C_INDEX(0x00);
LCD_ILI9881C_CMD(0x26);
LCD_ILI9881C_INDEX(0x00);
LCD_ILI9881C_CMD(0x27);
LCD_ILI9881C_INDEX(0x00);
LCD_ILI9881C_CMD(0x28);
LCD_ILI9881C_INDEX(0x33);
LCD_ILI9881C_CMD(0x29);
LCD_ILI9881C_INDEX(0x03);
LCD_ILI9881C_CMD(0x2A);
LCD_ILI9881C_INDEX(0x00);
LCD_ILI9881C_CMD(0x2B);
LCD_ILI9881C_INDEX(0x00);
LCD_ILI9881C_CMD(0x2C);
LCD_ILI9881C_INDEX(0x00);
LCD_ILI9881C_CMD(0x2D);
LCD_ILI9881C_INDEX(0x00);
LCD_ILI9881C_CMD(0x2E);
LCD_ILI9881C_INDEX(0x00);

LCD_ILI9881C_CMD(0x2F);
LCD_ILI9881C_INDEX(0x00);
LCD_ILI9881C_CMD(0x30);
LCD_ILI9881C_INDEX(0x00);
LCD_ILI9881C_CMD(0x31);
LCD_ILI9881C_INDEX(0x00);
LCD_ILI9881C_CMD(0x32);
LCD_ILI9881C_INDEX(0x00);
LCD_ILI9881C_CMD(0x33);
LCD_ILI9881C_INDEX(0x00);
LCD_ILI9881C_CMD(0x34);
LCD_ILI9881C_INDEX(0x04);
LCD_ILI9881C_CMD(0x35);
LCD_ILI9881C_INDEX(0x00);
LCD_ILI9881C_CMD(0x36);
LCD_ILI9881C_INDEX(0x00);
LCD_ILI9881C_CMD(0x37);
LCD_ILI9881C_INDEX(0x00);
LCD_ILI9881C_CMD(0x38);
LCD_ILI9881C_INDEX(0x3C);
LCD_ILI9881C_CMD(0x39);
LCD_ILI9881C_INDEX(0x00);
LCD_ILI9881C_CMD(0x3A);
LCD_ILI9881C_INDEX(0x00);
LCD_ILI9881C_CMD(0x3B);
LCD_ILI9881C_INDEX(0x00);
LCD_ILI9881C_CMD(0x3C);
LCD_ILI9881C_INDEX(0x00);
LCD_ILI9881C_CMD(0x3D);
LCD_ILI9881C_INDEX(0x00);
LCD_ILI9881C_CMD(0x3E);
LCD_ILI9881C_INDEX(0x00);
LCD_ILI9881C_CMD(0x3F);
LCD_ILI9881C_INDEX(0x00);
LCD_ILI9881C_CMD(0x40);
LCD_ILI9881C_INDEX(0x00);
LCD_ILI9881C_CMD(0x41);
LCD_ILI9881C_INDEX(0x00);
LCD_ILI9881C_CMD(0x42);



LCD_ILI9881C_INDEX(0x00);
LCD_ILI9881C_CMD(0x43);
LCD_ILI9881C_INDEX(0x00);
LCD_ILI9881C_CMD(0x44);
LCD_ILI9881C_INDEX(0x00);
LCD_ILI9881C_CMD(0x50);
LCD_ILI9881C_INDEX(0x10);
LCD_ILI9881C_CMD(0x51);
LCD_ILI9881C_INDEX(0x32);
LCD_ILI9881C_CMD(0x52);
LCD_ILI9881C_INDEX(0x54);
LCD_ILI9881C_CMD(0x53);
LCD_ILI9881C_INDEX(0x76);
LCD_ILI9881C_CMD(0x54);
LCD_ILI9881C_INDEX(0x98);
LCD_ILI9881C_CMD(0x55);
LCD_ILI9881C_INDEX(0xBA);
LCD_ILI9881C_CMD(0x56);
LCD_ILI9881C_INDEX(0x10);
LCD_ILI9881C_CMD(0x57);
LCD_ILI9881C_INDEX(0x32);
LCD_ILI9881C_CMD(0x58);
LCD_ILI9881C_INDEX(0x54);
LCD_ILI9881C_CMD(0x59);
LCD_ILI9881C_INDEX(0x76);
LCD_ILI9881C_CMD(0x5A);
LCD_ILI9881C_INDEX(0x98);
LCD_ILI9881C_CMD(0x5B);
LCD_ILI9881C_INDEX(0xBA);
LCD_ILI9881C_CMD(0x5C);
LCD_ILI9881C_INDEX(0xDC);
LCD_ILI9881C_CMD(0x5D);
LCD_ILI9881C_INDEX(0xFE);
LCD_ILI9881C_CMD(0x5E);
LCD_ILI9881C_INDEX(0x00);
LCD_ILI9881C_CMD(0x5F);
LCD_ILI9881C_INDEX(0x0E);
LCD_ILI9881C_CMD(0x60);
LCD_ILI9881C_INDEX(0x0F);

LCD_ILI9881C_CMD(0x61);
LCD_ILI9881C_INDEX(0x0C);
LCD_ILI9881C_CMD(0x62);
LCD_ILI9881C_INDEX(0x0D);
LCD_ILI9881C_CMD(0x63);
LCD_ILI9881C_INDEX(0x06);
LCD_ILI9881C_CMD(0x64);
LCD_ILI9881C_INDEX(0x07);
LCD_ILI9881C_CMD(0x65);
LCD_ILI9881C_INDEX(0x02);
LCD_ILI9881C_CMD(0x66);
LCD_ILI9881C_INDEX(0x02);
LCD_ILI9881C_CMD(0x67);
LCD_ILI9881C_INDEX(0x02);
LCD_ILI9881C_CMD(0x68);
LCD_ILI9881C_INDEX(0x02);
LCD_ILI9881C_CMD(0x69);
LCD_ILI9881C_INDEX(0x01);
LCD_ILI9881C_CMD(0x6A);
LCD_ILI9881C_INDEX(0x00);
LCD_ILI9881C_CMD(0x6B);
LCD_ILI9881C_INDEX(0x02);
LCD_ILI9881C_CMD(0x6C);
LCD_ILI9881C_INDEX(0x15);
LCD_ILI9881C_CMD(0x6D);
LCD_ILI9881C_INDEX(0x14);
LCD_ILI9881C_CMD(0x6E);
LCD_ILI9881C_INDEX(0x02);
LCD_ILI9881C_CMD(0x6F);
LCD_ILI9881C_INDEX(0x02);
LCD_ILI9881C_CMD(0x70);
LCD_ILI9881C_INDEX(0x02);
LCD_ILI9881C_CMD(0x71);
LCD_ILI9881C_INDEX(0x02);
LCD_ILI9881C_CMD(0x72);
LCD_ILI9881C_INDEX(0x02);
LCD_ILI9881C_CMD(0x73);
LCD_ILI9881C_INDEX(0x02);
LCD_ILI9881C_CMD(0x74);

LCD_ILI9881C_INDEX(0x02);
LCD_ILI9881C_CMD(0x75);
LCD_ILI9881C_INDEX(0x0E);
LCD_ILI9881C_CMD(0x76);
LCD_ILI9881C_INDEX(0x0F);
LCD_ILI9881C_CMD(0x77);
LCD_ILI9881C_INDEX(0x0C);
LCD_ILI9881C_CMD(0x78);
LCD_ILI9881C_INDEX(0x0D);
LCD_ILI9881C_CMD(0x79);
LCD_ILI9881C_INDEX(0x06);
LCD_ILI9881C_CMD(0x7A);
LCD_ILI9881C_INDEX(0x07);
LCD_ILI9881C_CMD(0x7B);
LCD_ILI9881C_INDEX(0x02);
LCD_ILI9881C_CMD(0x7C);
LCD_ILI9881C_INDEX(0x02);
LCD_ILI9881C_CMD(0x7D);
LCD_ILI9881C_INDEX(0x02);
LCD_ILI9881C_CMD(0x7E);
LCD_ILI9881C_INDEX(0x02);
LCD_ILI9881C_CMD(0x7F);
LCD_ILI9881C_INDEX(0x01);
LCD_ILI9881C_CMD(0x80);
LCD_ILI9881C_INDEX(0x00);
LCD_ILI9881C_CMD(0x81);
LCD_ILI9881C_INDEX(0x02);
LCD_ILI9881C_CMD(0x82);
LCD_ILI9881C_INDEX(0x14);
LCD_ILI9881C_CMD(0x83);
LCD_ILI9881C_INDEX(0x15);
LCD_ILI9881C_CMD(0x84);
LCD_ILI9881C_INDEX(0x02);
LCD_ILI9881C_CMD(0x85);
LCD_ILI9881C_INDEX(0x02);
LCD_ILI9881C_CMD(0x86);
LCD_ILI9881C_INDEX(0x02);
LCD_ILI9881C_CMD(0x87);
LCD_ILI9881C_INDEX(0x02);

LCD_ILI9881C_CMD(0x88);
LCD_ILI9881C_INDEX(0x02);
LCD_ILI9881C_CMD(0x89);
LCD_ILI9881C_INDEX(0x02);
LCD_ILI9881C_CMD(0x8A);
LCD_ILI9881C_INDEX(0x02);
LCD_ILI9881C_CMD(0xFF);
LCD_ILI9881C_INDEX(0x98);
LCD_ILI9881C_INDEX(0x81);
LCD_ILI9881C_INDEX(0x04);
LCD_ILI9881C_CMD(0x6C);
LCD_ILI9881C_INDEX(0x15);
LCD_ILI9881C_CMD(0x6E);
LCD_ILI9881C_INDEX(0x2A);
LCD_ILI9881C_CMD(0x6F);
LCD_ILI9881C_INDEX(0x33);
LCD_ILI9881C_CMD(0x3A);
LCD_ILI9881C_INDEX(0x94);
LCD_ILI9881C_CMD(0x8D);
LCD_ILI9881C_INDEX(0x14);
LCD_ILI9881C_CMD(0x87);
LCD_ILI9881C_INDEX(0xBA);
LCD_ILI9881C_CMD(0x26);
LCD_ILI9881C_INDEX(0x76);
LCD_ILI9881C_CMD(0xB2);
LCD_ILI9881C_INDEX(0xD1);
LCD_ILI9881C_CMD(0xB5);
LCD_ILI9881C_INDEX(0x06);
LCD_ILI9881C_CMD(0x38);
LCD_ILI9881C_INDEX(0x01);
LCD_ILI9881C_CMD(0x39);
LCD_ILI9881C_INDEX(0x00);
LCD_ILI9881C_CMD(0xFF);
LCD_ILI9881C_INDEX(0x98);
LCD_ILI9881C_INDEX(0x81);
LCD_ILI9881C_INDEX(0x01);
LCD_ILI9881C_CMD(0x22);
LCD_ILI9881C_INDEX(0x0A);
LCD_ILI9881C_CMD(0x31);

LCD_ILI9881C_INDEX(0x00);
LCD_ILI9881C_CMD(0x53);
LCD_ILI9881C_INDEX(0x7D);
LCD_ILI9881C_CMD(0x55);
LCD_ILI9881C_INDEX(0x8F);
LCD_ILI9881C_CMD(0x40);
LCD_ILI9881C_INDEX(0x33);
LCD_ILI9881C_CMD(0x50);
LCD_ILI9881C_INDEX(0x96);
LCD_ILI9881C_CMD(0x51);
LCD_ILI9881C_INDEX(0x96);
LCD_ILI9881C_CMD(0x60);
LCD_ILI9881C_INDEX(0x23);
LCD_ILI9881C_CMD(0xA0);
LCD_ILI9881C_INDEX(0x08);
LCD_ILI9881C_CMD(0xA1);
LCD_ILI9881C_INDEX(0x1D);
LCD_ILI9881C_CMD(0xA2);
LCD_ILI9881C_INDEX(0x2A);
LCD_ILI9881C_CMD(0xA3);
LCD_ILI9881C_INDEX(0x10);
LCD_ILI9881C_CMD(0xA4);
LCD_ILI9881C_INDEX(0x15);
LCD_ILI9881C_CMD(0xA5);
LCD_ILI9881C_INDEX(0x28);
LCD_ILI9881C_CMD(0xA6);
LCD_ILI9881C_INDEX(0x1C);
LCD_ILI9881C_CMD(0xA7);
LCD_ILI9881C_INDEX(0x1D);
LCD_ILI9881C_CMD(0xA8);
LCD_ILI9881C_INDEX(0x7E);
LCD_ILI9881C_CMD(0xA9);
LCD_ILI9881C_INDEX(0x1D);
LCD_ILI9881C_CMD(0xAA);
LCD_ILI9881C_INDEX(0x29);
LCD_ILI9881C_CMD(0xAB);
LCD_ILI9881C_INDEX(0x6B);
LCD_ILI9881C_CMD(0xAC);
LCD_ILI9881C_INDEX(0x1A);

LCD_ILI9881C_CMD(0xAD);
LCD_ILI9881C_INDEX(0x18);
LCD_ILI9881C_CMD(0xAE);
LCD_ILI9881C_INDEX(0x4B);
LCD_ILI9881C_CMD(0xAF);
LCD_ILI9881C_INDEX(0x20);
LCD_ILI9881C_CMD(0xB0);
LCD_ILI9881C_INDEX(0x27);
LCD_ILI9881C_CMD(0xB1);
LCD_ILI9881C_INDEX(0x50);
LCD_ILI9881C_CMD(0xB2);
LCD_ILI9881C_INDEX(0x64);
LCD_ILI9881C_CMD(0xB3);
LCD_ILI9881C_INDEX(0x39);
LCD_ILI9881C_CMD(0xC0);
LCD_ILI9881C_INDEX(0x08);
LCD_ILI9881C_CMD(0xC1);
LCD_ILI9881C_INDEX(0x1D);
LCD_ILI9881C_CMD(0xC2);
LCD_ILI9881C_INDEX(0x2A);
LCD_ILI9881C_CMD(0xC3);
LCD_ILI9881C_INDEX(0x10);
LCD_ILI9881C_CMD(0xC4);
LCD_ILI9881C_INDEX(0x15);
LCD_ILI9881C_CMD(0xC5);
LCD_ILI9881C_INDEX(0x28);
LCD_ILI9881C_CMD(0xC6);
LCD_ILI9881C_INDEX(0x1C);
LCD_ILI9881C_CMD(0xC7);
LCD_ILI9881C_INDEX(0x1D);
LCD_ILI9881C_CMD(0xC8);
LCD_ILI9881C_INDEX(0x7E);
LCD_ILI9881C_CMD(0xC9);
LCD_ILI9881C_INDEX(0x1D);
LCD_ILI9881C_CMD(0xCA);
LCD_ILI9881C_INDEX(0x29);
LCD_ILI9881C_CMD(0xCB);
LCD_ILI9881C_INDEX(0x6B);
LCD_ILI9881C_CMD(0xCC);



```
LCD_ILI9881C_INDEX(0x1A);
LCD_ILI9881C_CMD(0xCD);
LCD_ILI9881C_INDEX(0x18);
LCD_ILI9881C_CMD(0xCE);
LCD_ILI9881C_INDEX(0x4B);
LCD_ILI9881C_CMD(0xCF);
LCD_ILI9881C_INDEX(0x20);
LCD_ILI9881C_CMD(0xD0);
LCD_ILI9881C_INDEX(0x27);
LCD_ILI9881C_CMD(0xD1);
LCD_ILI9881C_INDEX(0x50);
LCD_ILI9881C_CMD(0xD2);
LCD_ILI9881C_INDEX(0x64);
LCD_ILI9881C_CMD(0xD3);
LCD_ILI9881C_INDEX(0x39);
LCD_ILI9881C_CMD(0xFF);
LCD_ILI9881C_INDEX(0x98);
LCD_ILI9881C_INDEX(0x81);
LCD_ILI9881C_INDEX(0x00);
LCD_ILI9881C_CMD(0x35);
LCD_ILI9881C_INDEX(0x00);
Void ILI9881C_ExitSleep_Code(Void)
{
LCD_ILI9881C_CMD(0x11); // Sleep Out
Delays(120);
LCD_ILI9881C_CMD(0x29) //Display on
Delays(20);
}
```

3. QUALITY ASSURANCE SYSTEM

3.1 Quality Assurance Flow Chart

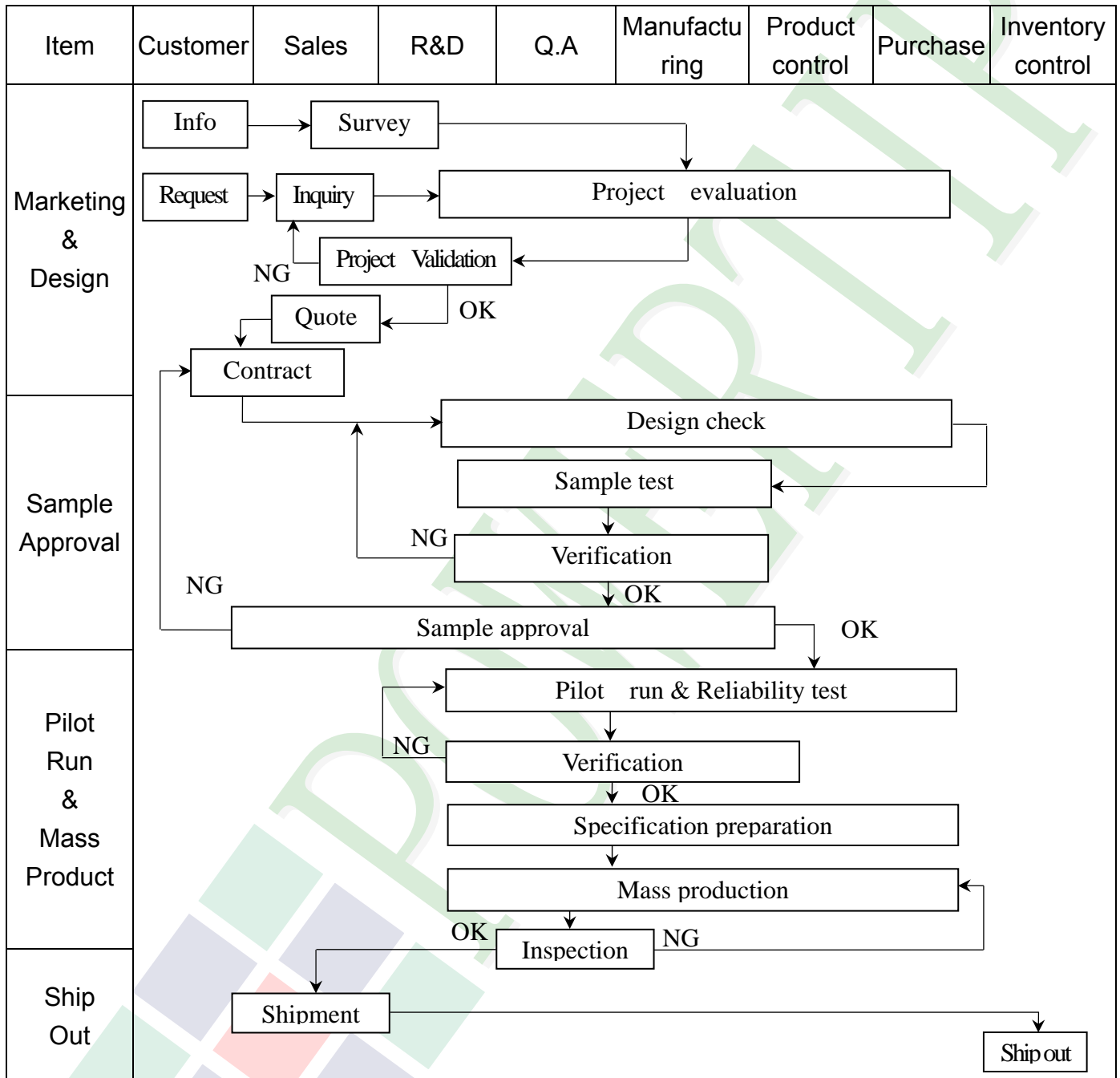

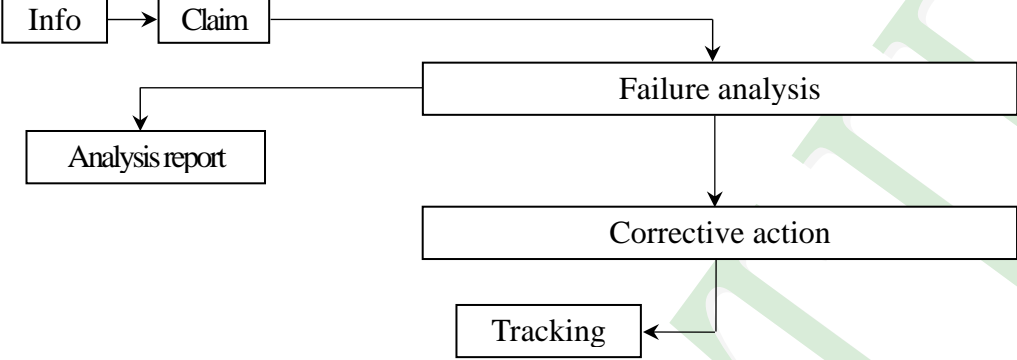
Item	Customer	Sales	R&D	Q.A	Manufacturing	Product control	Purchase	Inventory control
Sales Service	 <pre> graph TD Info[Info] --> Claim[Claim] Claim --> Failure[Failure analysis] Failure --> Report[Analysis report] Failure --> Action[Corrective action] Action --> Tracking[Tracking] </pre>							
Q.A Activity	1. ISO 9001 Maintenance Activities 3. Equipment calibration 5. Standardization Management				2. Process improvement proposal 4. Education And Training Activities			

3.2. Inspection Specification

- ◆Scope: The document shall be applied to TFT-LCD Module for 3.5" -15" (Ver.B01).
- ◆Inspection Standard: MIL-STD-105E Table Normal Inspection Single Sampling Level II.
- ◆Equipment: Gauge, MIL-STD, Powertip Tester, Sample
- ◆Defect Level: Major Defect AQL: 0.4; Minor Defect AQL: 1.5
- ◆OUT Going Defect Level: Sampling.
- ◆Standard of the product appearance test:

a. Manner of appearance test:

- (1). The test best be under 20W×2 fluorescent light(about 300lux ~500lux), and distance of view must be at 30~40 cm.
- (2). The test direction is base on about around 45° of vertical line.

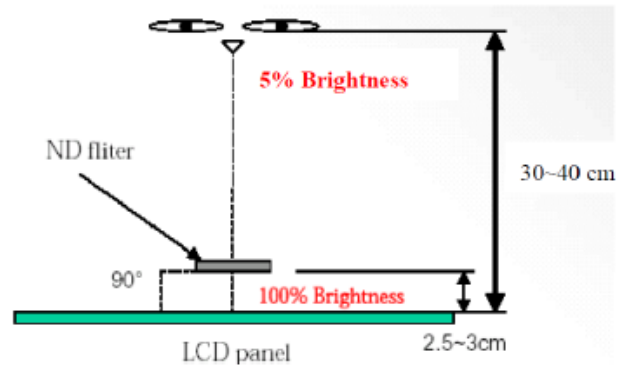
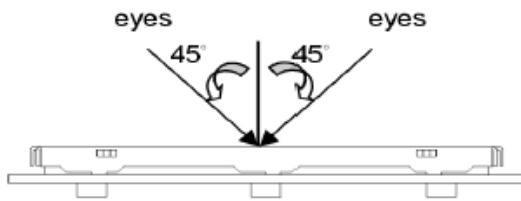

(3). Definition of area.

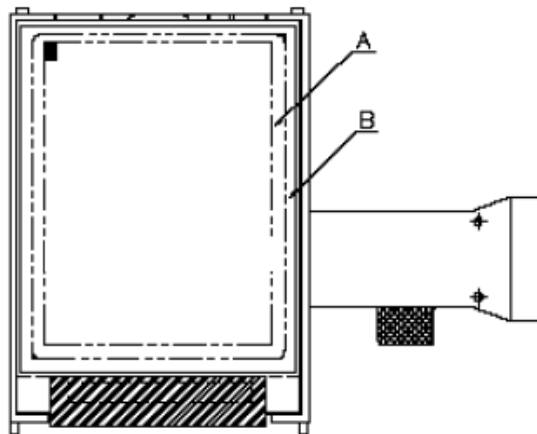

A area: viewing area

B area: Outside of viewing area

(4). Standard of inspection : (Unit : mm)

◆ Specification For TFT-LCD Module 3.5" ~15" :

(Ver.B01)

NO	Item	Criterion	Level												
01	Product condition	1. 1 The part number is inconsistent with work order of production.	Major												
		1. 2 Mixed product types.	Major												
		1. 3 Assembled in inverse direction.	Major												
02	Quantity	2. 1 The quantity is inconsistent with work order of production.	Major												
03	Outline dimension	3. 1 Product dimension and structure must conform to structure diagram.	Major												
04	Electrical Testing	4. 1 Missing line character and icon.	Major												
		4. 2 No function or no display.	Major												
		4. 3 Display malfunction.	Major												
		4. 4 LCD viewing angle defect.	Major												
		4. 5 Current consumption exceeds product specifications.	Major												
		4. 6 Mura cannot be seen through 5% ND filter at 50% Gray, should be judged by the viewing angle of 90 degree.	Minor												
05	Dot defect (Bright dot, Dark dot) On -display	<table border="1" style="margin-left: auto; margin-right: auto;"> <thead> <tr> <th colspan="2">Item</th> <th>Acceptance (Q'ty)</th> </tr> </thead> <tbody> <tr> <td rowspan="4" style="text-align: center; vertical-align: middle;">Dot Defect</td> <td style="text-align: center;">Bright Dot</td> <td style="text-align: center;">≤ 4</td> </tr> <tr> <td style="text-align: center;">Dark Dot</td> <td style="text-align: center;">≤ 5</td> </tr> <tr> <td style="text-align: center;">Joint Dot</td> <td style="text-align: center;">≤ 3</td> </tr> <tr> <td style="text-align: center;">Total</td> <td style="text-align: center;">≤ 7</td> </tr> </tbody> </table>	Item		Acceptance (Q'ty)	Dot Defect	Bright Dot	≤ 4	Dark Dot	≤ 5	Joint Dot	≤ 3	Total	≤ 7	Minor
		Item		Acceptance (Q'ty)											
Dot Defect	Bright Dot	≤ 4													
	Dark Dot	≤ 5													
	Joint Dot	≤ 3													
	Total	≤ 7													
5. 1 Inspection pattern: full white, full black, Red, Green and blue screens. 5. 2 It is defined as dot defect if defect area $> 1/2$ dot. 5. 3 The distance between two dot defect ≥ 5 mm. 5. 4 Bright dot that can not be seen through 5% ND filter.															

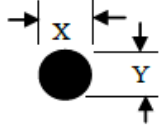
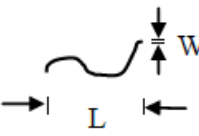

◆ Specification For TFT-LCD Module 3.5" ~15" :

(Ver.B01)

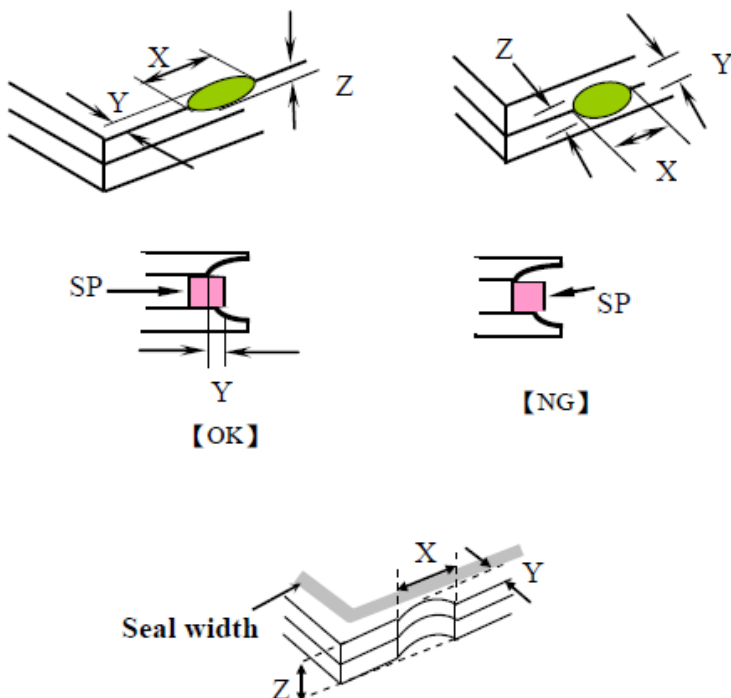
NO	Item	Criterion	Level																																																							
06	Black or white Dot, scratch, contamination Round type  $\Phi = (x + y) / 2$ Line type 	6.1 Round type (Non-display or display): <table border="1"> <thead> <tr> <th rowspan="2">Dimension (diameter : Φ)</th> <th colspan="2">Acceptance (Q'ty)</th> </tr> <tr> <th>A area</th> <th>B area</th> </tr> </thead> <tbody> <tr> <td>$\Phi \leq 0.25$</td> <td colspan="2">Ignore</td> </tr> <tr> <td>$0.25 < \Phi \leq 0.50$</td> <td>5</td> <td rowspan="3">Ignore</td> </tr> <tr> <td>$\Phi > 0.50$</td> <td>0</td> </tr> <tr> <td>Total</td> <td>5</td> </tr> </tbody> </table> 6.2 Line type(Non-display or display): <table border="1"> <thead> <tr> <th rowspan="2">module size</th> <th rowspan="2">Length (L)</th> <th rowspan="2">Width (W)</th> <th colspan="2">Acceptance (Q'ty)</th> </tr> <tr> <th>A area</th> <th>B area</th> </tr> </thead> <tbody> <tr> <td rowspan="5">3.5" to less 9"</td> <td>---</td> <td>$W \leq 0.03$</td> <td>Ignore</td> <td rowspan="5">Ignore</td> </tr> <tr> <td>$L \leq 10.0$</td> <td>$0.03 < W \leq 0.05$</td> <td>4</td> </tr> <tr> <td>$L \leq 5.0$</td> <td>$0.05 < W \leq 0.10$</td> <td>2</td> </tr> <tr> <td>---</td> <td>$W > 0.10$</td> <td>As round type</td> </tr> <tr> <td colspan="3">Total</td> <td>5</td> </tr> <tr> <td rowspan="5">9" to 15"</td> <td>---</td> <td>$W \leq 0.05$</td> <td>Ignore</td> <td rowspan="5">Ignore</td> </tr> <tr> <td>$L \leq 10.0$</td> <td>$0.05 < W \leq 0.10$</td> <td>5</td> </tr> <tr> <td>---</td> <td>$W > 0.10$</td> <td>As round type</td> </tr> <tr> <td colspan="3">Total</td> <td>5</td> </tr> </tbody> </table>	Dimension (diameter : Φ)	Acceptance (Q'ty)		A area	B area	$\Phi \leq 0.25$	Ignore		$0.25 < \Phi \leq 0.50$	5	Ignore	$\Phi > 0.50$	0	Total	5	module size	Length (L)	Width (W)	Acceptance (Q'ty)		A area	B area	3.5" to less 9"	---	$W \leq 0.03$	Ignore	Ignore	$L \leq 10.0$	$0.03 < W \leq 0.05$	4	$L \leq 5.0$	$0.05 < W \leq 0.10$	2	---	$W > 0.10$	As round type	Total			5	9" to 15"	---	$W \leq 0.05$	Ignore	Ignore	$L \leq 10.0$	$0.05 < W \leq 0.10$	5	---	$W > 0.10$	As round type	Total			5	Minor
Dimension (diameter : Φ)	Acceptance (Q'ty)																																																									
	A area	B area																																																								
$\Phi \leq 0.25$	Ignore																																																									
$0.25 < \Phi \leq 0.50$	5	Ignore																																																								
$\Phi > 0.50$	0																																																									
Total	5																																																									
module size	Length (L)	Width (W)	Acceptance (Q'ty)																																																							
			A area	B area																																																						
3.5" to less 9"	---	$W \leq 0.03$	Ignore	Ignore																																																						
	$L \leq 10.0$	$0.03 < W \leq 0.05$	4																																																							
	$L \leq 5.0$	$0.05 < W \leq 0.10$	2																																																							
	---	$W > 0.10$	As round type																																																							
	Total				5																																																					
9" to 15"	---	$W \leq 0.05$	Ignore	Ignore																																																						
	$L \leq 10.0$	$0.05 < W \leq 0.10$	5																																																							
	---	$W > 0.10$	As round type																																																							
	Total				5																																																					
	07	Polarizer Bubble	<table border="1"> <thead> <tr> <th rowspan="2">Dimension (diameter: Φ)</th> <th colspan="2">Acceptance (Q'ty)</th> </tr> <tr> <th>A area</th> <th>B area</th> </tr> </thead> <tbody> <tr> <td>$\Phi \leq 0.25$</td> <td colspan="2">Ignore</td> </tr> <tr> <td>$0.25 < \Phi \leq 0.50$</td> <td>4</td> <td rowspan="4">Ignore</td> </tr> <tr> <td>$0.50 < \Phi \leq 0.80$</td> <td>1</td> </tr> <tr> <td>$\Phi > 0.80$</td> <td>0</td> </tr> <tr> <td>Total</td> <td>5</td> </tr> </tbody> </table>		Dimension (diameter: Φ)	Acceptance (Q'ty)		A area	B area	$\Phi \leq 0.25$	Ignore		$0.25 < \Phi \leq 0.50$	4	Ignore	$0.50 < \Phi \leq 0.80$	1	$\Phi > 0.80$	0	Total	5	Minor																																				
Dimension (diameter: Φ)	Acceptance (Q'ty)																																																									
	A area	B area																																																								
$\Phi \leq 0.25$	Ignore																																																									
$0.25 < \Phi \leq 0.50$	4	Ignore																																																								
$0.50 < \Phi \leq 0.80$	1																																																									
$\Phi > 0.80$	0																																																									
Total	5																																																									

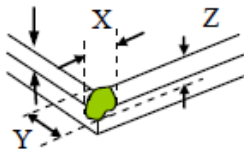
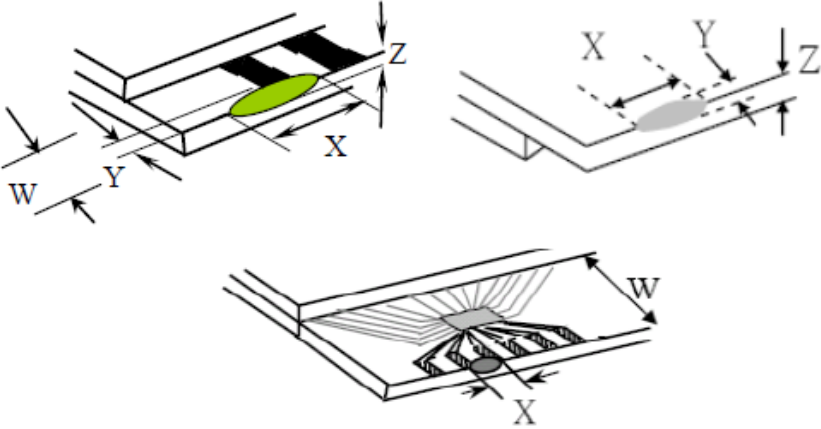
NO	Item	Criterion	Level						
08	The crack of glass	<p>Symbols :</p> <p>X: The length of crack Y: The width of crack. Z: The thickness of crack W: terminal length t: The thickness of glass a: LCD side length</p>	Minor						
		<p>8.1 General glass chip: 8.1.1 Chip on panel surface and crack between panels:</p>  <table border="1" data-bbox="542 1523 1324 1803"> <thead> <tr> <th>X</th> <th>Y</th> <th>Z</th> </tr> </thead> <tbody> <tr> <td>$\leq a$</td> <td>Crack can't enter viewing area</td> <td>$\leq 1/2 t$</td> </tr> <tr> <td>$\leq a$</td> <td>Crack can't exceed the half of SP width.</td> <td>$1/2 t < Z \leq 2 t$</td> </tr> </tbody> </table>		X	Y	Z	$\leq a$	Crack can't enter viewing area	$\leq 1/2 t$
X	Y	Z							
$\leq a$	Crack can't enter viewing area	$\leq 1/2 t$							
$\leq a$	Crack can't exceed the half of SP width.	$1/2 t < Z \leq 2 t$							

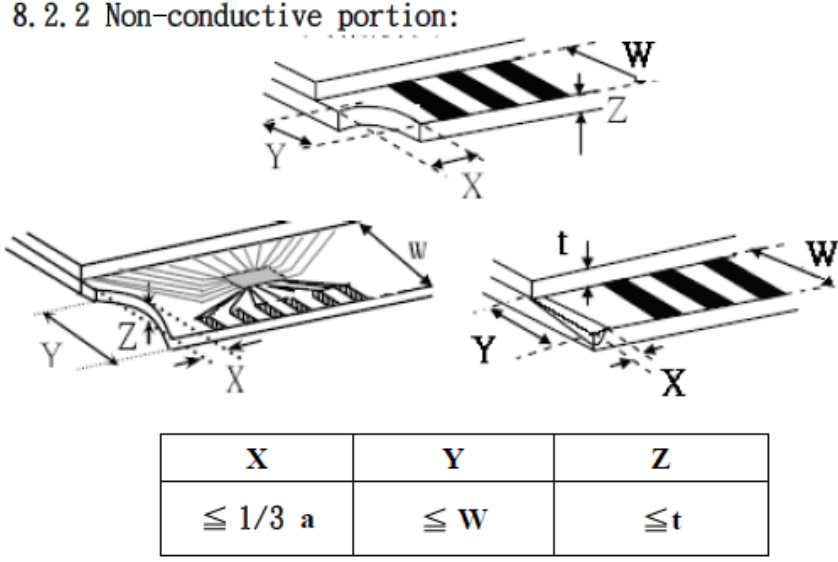
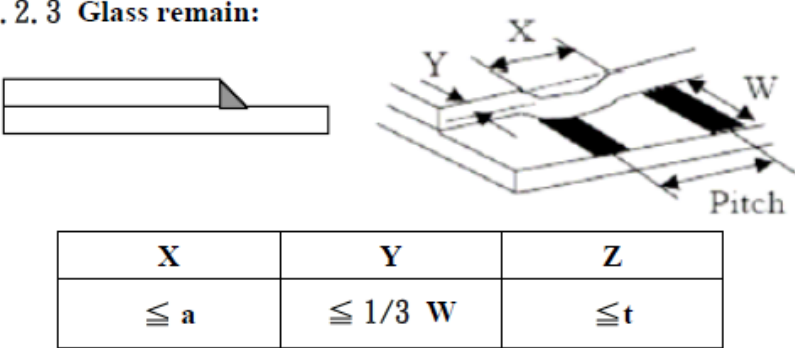
NO	Item	Criterion	Level												
08	The crack of glass	<p>Symbols :</p> <p>X: The length of crack Z: The thickness of crack t: The thickness of glass</p> <p>Y: The width of crack. W: terminal length a: LCD side length</p>	Minor												
		<p>8.1.2 Corner crack:</p>  <table border="1" data-bbox="528 757 1326 1048"> <thead> <tr> <th>X</th> <th>Y</th> <th>Z</th> </tr> </thead> <tbody> <tr> <td>$\leq 1/5 a$</td> <td>Crack can't enter viewing area</td> <td>$Z \leq 1/2 t$</td> </tr> <tr> <td>$\leq 1/5 a$</td> <td>Crack can't exceed the half of SP width.</td> <td>$1/2 t < Z \leq 2 t$</td> </tr> </tbody> </table>		X	Y	Z	$\leq 1/5 a$	Crack can't enter viewing area	$Z \leq 1/2 t$	$\leq 1/5 a$	Crack can't exceed the half of SP width.	$1/2 t < Z \leq 2 t$			
X	Y	Z													
$\leq 1/5 a$	Crack can't enter viewing area	$Z \leq 1/2 t$													
$\leq 1/5 a$	Crack can't exceed the half of SP width.	$1/2 t < Z \leq 2 t$													
		<p>8.2 Protrusion over terminal:</p> <p>8.2.1 Chip on electrode pad:</p>  <table border="1" data-bbox="563 1675 1337 1843"> <thead> <tr> <th></th> <th>X</th> <th>Y</th> <th>Z</th> </tr> </thead> <tbody> <tr> <td>Front</td> <td>$\leq a$</td> <td>$\leq 1/2 W$</td> <td>$\leq t$</td> </tr> <tr> <td>Back</td> <td>$\leq a$</td> <td>$\leq W$</td> <td>$\leq 1/2 t$</td> </tr> </tbody> </table>		X	Y	Z	Front	$\leq a$	$\leq 1/2 W$	$\leq t$	Back	$\leq a$	$\leq W$	$\leq 1/2 t$	
	X	Y	Z												
Front	$\leq a$	$\leq 1/2 W$	$\leq t$												
Back	$\leq a$	$\leq W$	$\leq 1/2 t$												

NO	Item	Criterion	Level												
08	The crack of glass	<p>Symbols:</p> <p>X: The length of crack Y: The width of crack. Z: The thickness of crack W: terminal length t: The thickness of glass a: LCD side length</p> <p>8.2.2 Non-conductive portion:</p>  <table border="1" style="margin-left: auto; margin-right: auto;"> <thead> <tr> <th style="text-align: center;">X</th> <th style="text-align: center;">Y</th> <th style="text-align: center;">Z</th> </tr> </thead> <tbody> <tr> <td style="text-align: center;">$\leq 1/3 a$</td> <td style="text-align: center;">$\leq W$</td> <td style="text-align: center;">$\leq t$</td> </tr> </tbody> </table> <p>⊙ If the chipped area touches the ITO terminal, over 2/3 of the ITO must remain and be inspected according to electrode terminal specifications.</p> <p>8.2.3 Glass remain:</p>  <table border="1" style="margin-left: auto; margin-right: auto;"> <thead> <tr> <th style="text-align: center;">X</th> <th style="text-align: center;">Y</th> <th style="text-align: center;">Z</th> </tr> </thead> <tbody> <tr> <td style="text-align: center;">$\leq a$</td> <td style="text-align: center;">$\leq 1/3 W$</td> <td style="text-align: center;">$\leq t$</td> </tr> </tbody> </table> <p>8.2.4 Cracking:</p>  <p style="text-align: center;">Not Allowed</p>	X	Y	Z	$\leq 1/3 a$	$\leq W$	$\leq t$	X	Y	Z	$\leq a$	$\leq 1/3 W$	$\leq t$	Minor
X	Y	Z													
$\leq 1/3 a$	$\leq W$	$\leq t$													
X	Y	Z													
$\leq a$	$\leq 1/3 W$	$\leq t$													

◆ Specification For TFT-LCD Module 3. 5" ~15" :

(Ver.B01)

NO	Item	Criterion	Level
09	Backlight elements	9. 1 Backlight can't work normally.	Major
		9. 2 Backlight doesn't light or color is wrong.	Major
		9. 3 Illumination source flickers when lit.	Major
10	General appearance	10. 1 Pin type 、 quantity 、 dimension must match type in structure diagram.	Major
		10. 2 No short circuits in components on PCB or FPC.	Major
		10. 3 Parts on PCB or FPC must be: no wrong parts, missing parts or excess parts.	Major
		10. 4 Product packaging must the same as specified on packaging specification sheet.	Minor
		10. 5 The folding and peeled off in polarizer are not acceptable.	Minor
		10. 6 The PCB or FPC between B/L assembled distance(PCB or FPC) is ≤ 1.5 mm.	Minor

4. RELIABILITY TEST

4.1 Reliability Test Condition

(Ver.B01)

NO.	TEST ITEM	TEST CONDITION											
1	High Temperature Storage Test	Keep in $80 \pm 5^{\circ}\text{C}$ 240 hrs											
2	Low Temperature Storage Test	Keep in $-30 \pm 5^{\circ}\text{C}$ 240 hrs											
3	High Temperature / High Humidity Storage Test	Keep in 60°C / 90% R.H duration for 96 hrs (Excluding the polarizer)											
4	Temperature Cycling Storage Test	$\begin{array}{ccccccc} -30^{\circ}\text{C} & \rightarrow & +25^{\circ}\text{C} & \rightarrow & 80^{\circ}\text{C} & \rightarrow & +25^{\circ}\text{C} \\ (30\text{mins}) & & (5\text{mins}) & & (30\text{mins}) & & (5\text{mins}) \\ \leftarrow & & & & & & \rightarrow \\ & & & & 20 \text{ Cycle} & & \end{array}$											
5	ESD Test	Air Discharge: Apply 2 KV with 5 times Discharge for each polarity +/-	Contact Discharge: Apply 250 V with 5 times discharge for each polarity +/-										
		1. Temperature ambience : $15^{\circ}\text{C} \sim 35^{\circ}\text{C}$ 2. Humidity relative : 30%~60% 3. Energy Storage Capacitance(Cs+Cd) : $150\text{pF} \pm 10\%$ 4. Discharge Resistance(Rd) : $330\Omega \pm 10\%$ 5. Discharge, mode of operation : Single Discharge (time between successive discharges at least 1 sec) (Tolerance if the output voltage indication : $\pm 5\%$)											
6	Vibration Test (Packaged)	1. Sine wave $10 \sim 55$ Hz frequency (1 min/sweep) 2. The amplitude of vibration : 1.5 mm 3. Each direction (X、Y、Z) duration for 2 Hrs											
7	Drop Test (Packaged)	<table border="1" style="width: 100%; border-collapse: collapse; text-align: center;"> <thead> <tr> <th>Packing Weight (Kg)</th> <th>Drop Height (cm)</th> </tr> </thead> <tbody> <tr> <td>0 ~ 45.4</td> <td>122</td> </tr> <tr> <td>45.4 ~ 90.8</td> <td>76</td> </tr> <tr> <td>90.8 ~ 454</td> <td>61</td> </tr> <tr> <td>Over 454</td> <td>46</td> </tr> </tbody> </table>		Packing Weight (Kg)	Drop Height (cm)	0 ~ 45.4	122	45.4 ~ 90.8	76	90.8 ~ 454	61	Over 454	46
		Packing Weight (Kg)	Drop Height (cm)										
		0 ~ 45.4	122										
		45.4 ~ 90.8	76										
		90.8 ~ 454	61										
Over 454	46												
Drop Direction : ※1 corner / 3 edges / 6 sides each 1time													

◎Result Evaluation Criteria :

Under the display quality test conditions with normal operations with normal operation state.
 Do not change these conditions as such changes may affect practical display function.
 (Normal operation state)

Temperature : $+20 \sim 30^{\circ}\text{C}$

Humidity : 50~70%

Atmospheric pressure : 86~106Kpa

5. PRECAUTION RELATING PRODUCT HANDLING

5.1 SAFETY

- 5.1.1 If the LCD panel breaks, be careful not to get the liquid crystal to touch your skin.
- 5.1.2 If the liquid crystal touches your skin or clothes, please wash it off immediately by using soap and water.

5.2 HANDLING

- 5.2.1 Avoid any strong mechanical shock which can break the glass.
- 5.2.2 Avoid static electricity which can damage the CMOS LSI—When working with the module, be sure to ground your body and any electrical equipment you may be using.
- 5.2.3 Do not remove the panel or frame from the module.
- 5.2.4 The polarizing plate of the display is very fragile. So, please handle it very carefully, do not touch, push or rub the exposed polarizing with anything harder than an HB pencil lead (glass, tweezers, etc.)
- 5.2.5 Do not wipe the polarizing plate with a dry cloth, as it may easily scratch the surface of plate.
- 5.2.6 Do not touch the display area with bare hands, this will stain the display area.
- 5.2.7 Do not use ketonics solvent & aromatic solvent. Use with a soft cloth soaked with a cleaning naphtha solvent.
- 5.2.8 To control temperature and time of soldering is $320 \pm 10^{\circ}\text{C}$ and 3-5 sec.
- 5.2.9 To avoid liquid (include organic solvent) stained on LCM
- 5.2.10 Caution!(LCM products with Capacitive Touch Panel)
Strong EMI-sources such as switch-mode power supplies (SMPS) can lead to touch malfunction (e.g. ghost-touches).
Therefore, the touch needs to be thoroughly tested inside the target application.
- 5.2.11 CAUTION: Continuously displaying same static image will result in high possibility of image sticking/image burn-in effect due to TFT panel characteristic.

5.3 STORAGE

- 5.3.1 Store the panel or module in a dark place where the temperature is $25^{\circ}\text{C} \pm 5^{\circ}\text{C}$ and the humidity is below 65% RH.
- 5.3.2 Do not place the module near organics solvents or corrosive gases.
- 5.3.3 Do not crush, shake, or jolt the module.

5.4 TERMS OF WARRANTY

- 5.4.1 Applicable warrant period The period is within thirteen months since the date of shipping out under normal using and storage conditions.
- 5.4.2 Unaccepted responsibility
This product has been manufactured to your company's specification as a part for use in your company's general electronic products. It is guaranteed to perform according to delivery specifications. For any other use apart from general electronic equipment, we cannot take responsibility if the product is used in nuclear power control equipment, aerospace equipment, fire and security systems or any other applications in which there is a direct risk to human life and where extremely high levels of reliability are required.

A B C D E F G H

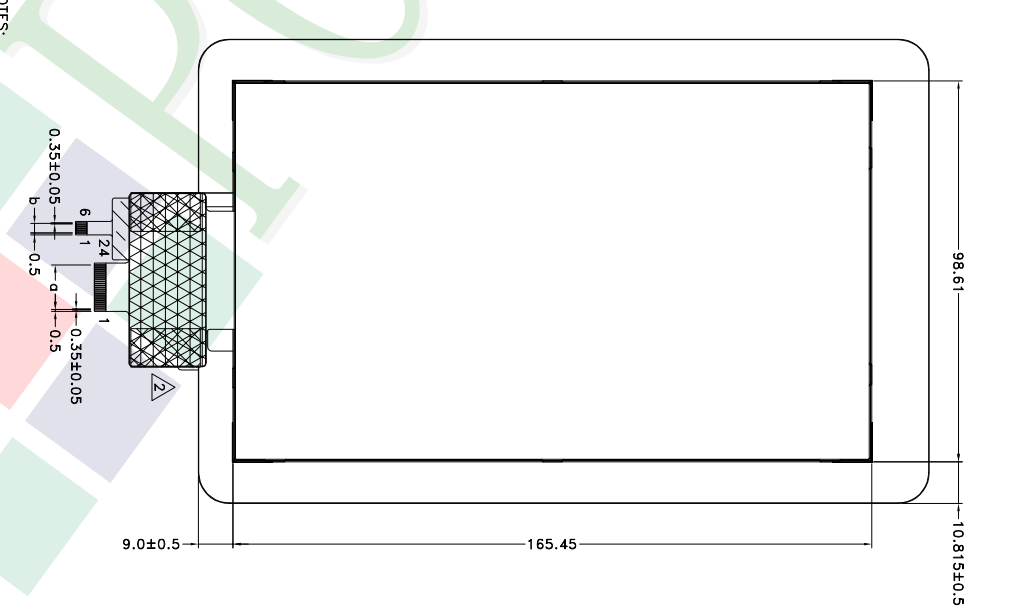
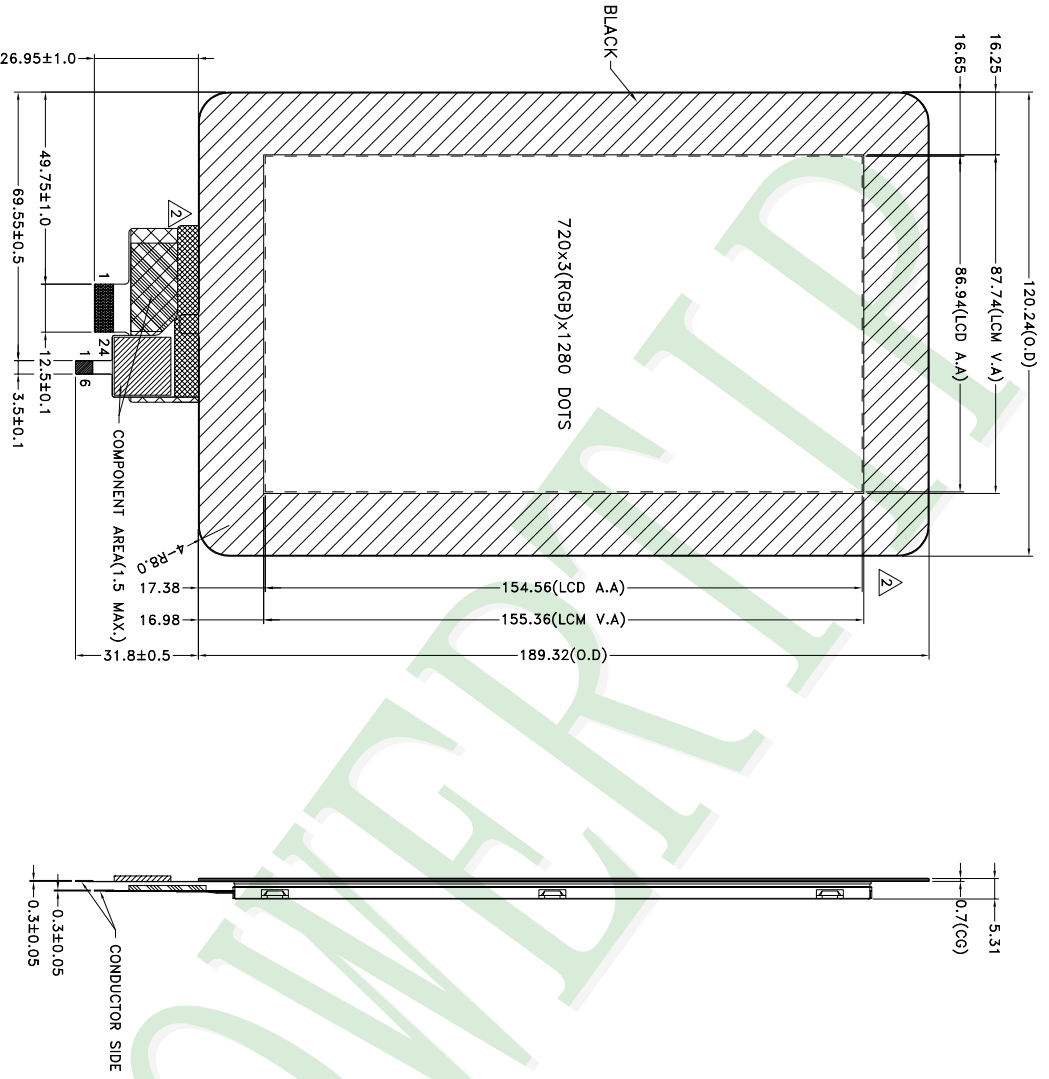

- NOTES:
- 1.LCD TYPE: TFT LCD
 - 2.LCD DISPLAY: Normally Black
 - 3.The tolerance unless classified $\pm 0.3\text{mm}$
 - 4.I/T/P suggested connector: "Cvilux" CF31061D0R2-05-NH OR EQUIVALENT
 - 5.I/FTI suggested connector: "CHIYAO SHUINN" JS-1191DR1-24 OR EQUIVALENT
 - 6.a:P0.5X23=11.5±0.05
 - 7.b:P0.5X5=2.5±0.05

007			
006			
005			
004			
003			
002	MODIFY DRAWING	Stone	2020/03/17
001	NEW DRAWING	Stone	2019/05/03
REV		REV BY	DATE

PART NO:	PH720128T005-ZBC
DRAWING NAME:	LMD-PH720128T005-ZBC
TITLE:	LCD MODULE DRAWING

Design	Stone	Surface	Precision Level
	Check		
Approve	Oliver	Scale	Quantity
	Oliver	1:1	1/1
		Page	250 ~ 1000

久正光电股份有限公司
POWER TIP TECHNOLOGY CORPORATION

Unit	MM	Material	Thickness
1	~ 4	-	-
4	~ 16	-	-
16	~ 63	-	-
63	~ 250	-	-
250	~ 1000	-	-

Ver.001

Documents NO. PKG-PH720128T005-ZBC

LCM包裝規格書

LCM Packaging Specifications

Approve	Check	Contact
Oliver	Oliver	Stone

1. 包裝材料規格表 (Packaging Material) : (per carton)

No.	Item	Model	Dimensions (mm)	1Pcs Weight	Quantity	Total Weight
1	成品 (LCM)	PH720128T005-ZBC	120.24 X 189.32	0.17	28	4.76
2	氣泡袋(1)Bubble Bag	BAG200160BRABA	200 X 160	0.0096	28	0.2688
3	A6隔板(2)A6 Partition	BX33800012BZBA	338 X 125 X 3	0.038	16	0.608
4	B6隔板(3)B6 Partition	BX29800012BZBA	298 X 125 X 3	0.023	4	0.092
5	海綿墊(4)Foam Rubber Cushion	OTFOAM00005ABA	330 X 290 X 10	0.025	4	0.1
6	舒美墊(5)EPE	OTFOAMT0006ABA	218 X 125 X 20	0.012	4	0.048
7	C4內盒(6)Product Box	BX36031014AABA	360 X 310 X 142	0.406	2	0.812
8	外紙箱(7)Carton	BX39432432CCBA	394 X 324 X 321	0.884	1	0.884
9						

2. 一整箱總重量 (Total LCD Weight in carton) : 7.58 Kg±10%

3. 單箱數量規格表 (Packaging Specifications and Quantity) :

(1)Quantity Of Spacer : A6隔板 X 8 , B6隔板 X 2

(2)Total LCM quantity in carton : quantity per box 14 x no of boxes 2 = 28

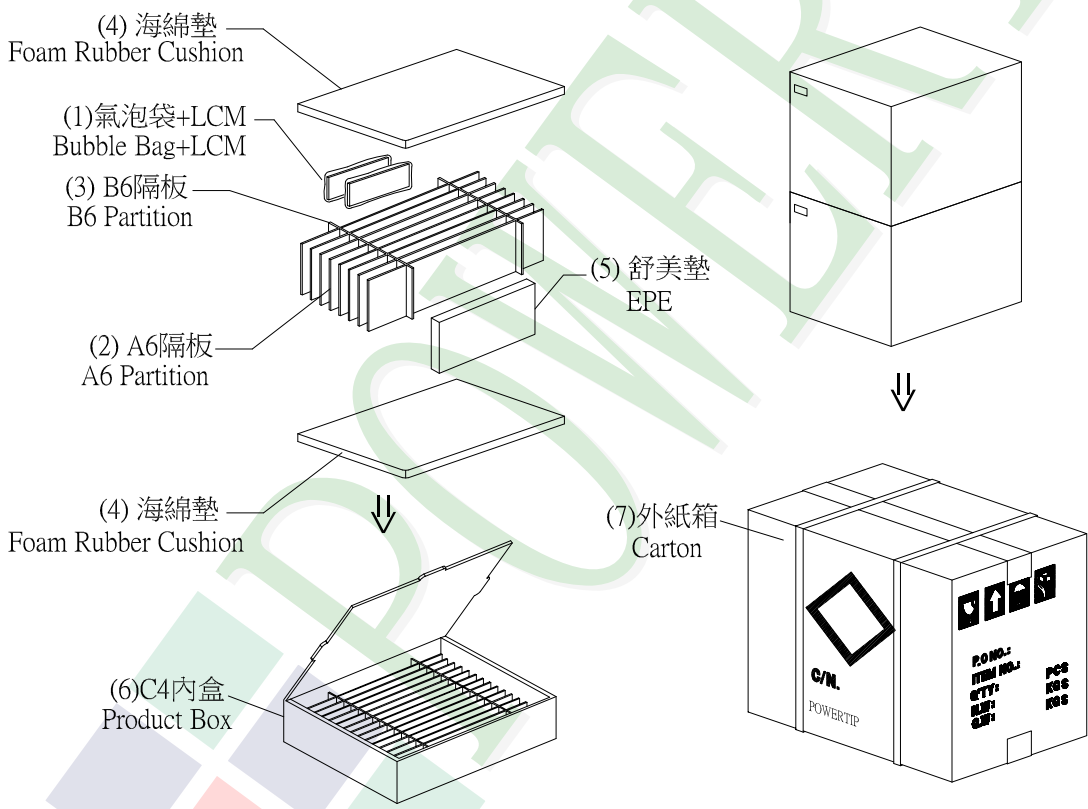

特記事項 (REMARK)

4. 每個間隔放2片模組，前後間隔不放置模組。(如示意圖)
 4. 2 LCM are placed on every other slot of the divider.
 Note: First and last slot should be empty.
 (See remarks 5 on packaging specifications)

5. 放置格示意圖:
 5. Each divider is placed inside a product Box

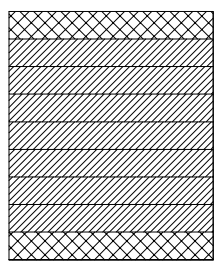

▨ 模組(LCM) X 2pcs.
 ▩ 舒美墊(EPE)