



深圳市福瑞达显示技术有限公司
SHENZHEN FRIDA LCD CO.,LTD

Doc.No.:FRD350H45041-D

REV : A

PAGE : 1/16

SPEC TITLE
DOCUMENT CONTROL SPECIFICATION

EFFECTIVE DATE : 2018-09-20

PRODUCT SPECIFICATION

TFT-LCD MODULE

Model No: FRD350H45041-D

For Customer's Acceptance	
Approved by	Comment

	Signature	Date
Prepared by	梁媛斌	2018.9.20
Checked by		2018.9.20
Approved by	胡凯	2018.9.20

深圳市福瑞达显示技术有限公司

地址: 深圳市光明新区公明田寮第二工业区田荣路68号

Add:The 68th,Tianrong Road,Tianliao Community,Gongming Town,Guangming new district, shenzhen.

电话(Tel):(0755)33563741 (0755)33563743

传真(Fax):(0755)29351371

网址(Web):www.fridalcd.com



Contents

No.	ITEM
1	Document Revision History
2	General Description
3	Outline Dimension
4	Interface Specification
5	Absolute Maximum Ratings
6	Electrical Specifications
7	Timing Characteristics
8	Power Supply Configuration
9	Optical Specification
10	Reliability Test Items
11	Precautions



1. Document Revision History :

DOCUMENT REVISION	DATE	DESCRIPTION	PREPARED BY
A	2018-09-20	First Release.	



2. General Description

No	Item	Specification	Remark
1	Screen Size	3.5 inch	
2	Display Mode	Normally White	
3	Resolution	320 × RGB × 480	
4	Active Area	48.96*73.44	mm
5	Outline Dimension	54.66*82.94*3.45	mm
6	Viewing Direction	12 o' clock	
7	Driver IC	HX8357D	
8	Interface	RGB	
9	Back Light	White Led*6	
10	Touch Panel	With RTP	

3. Outline Dimension

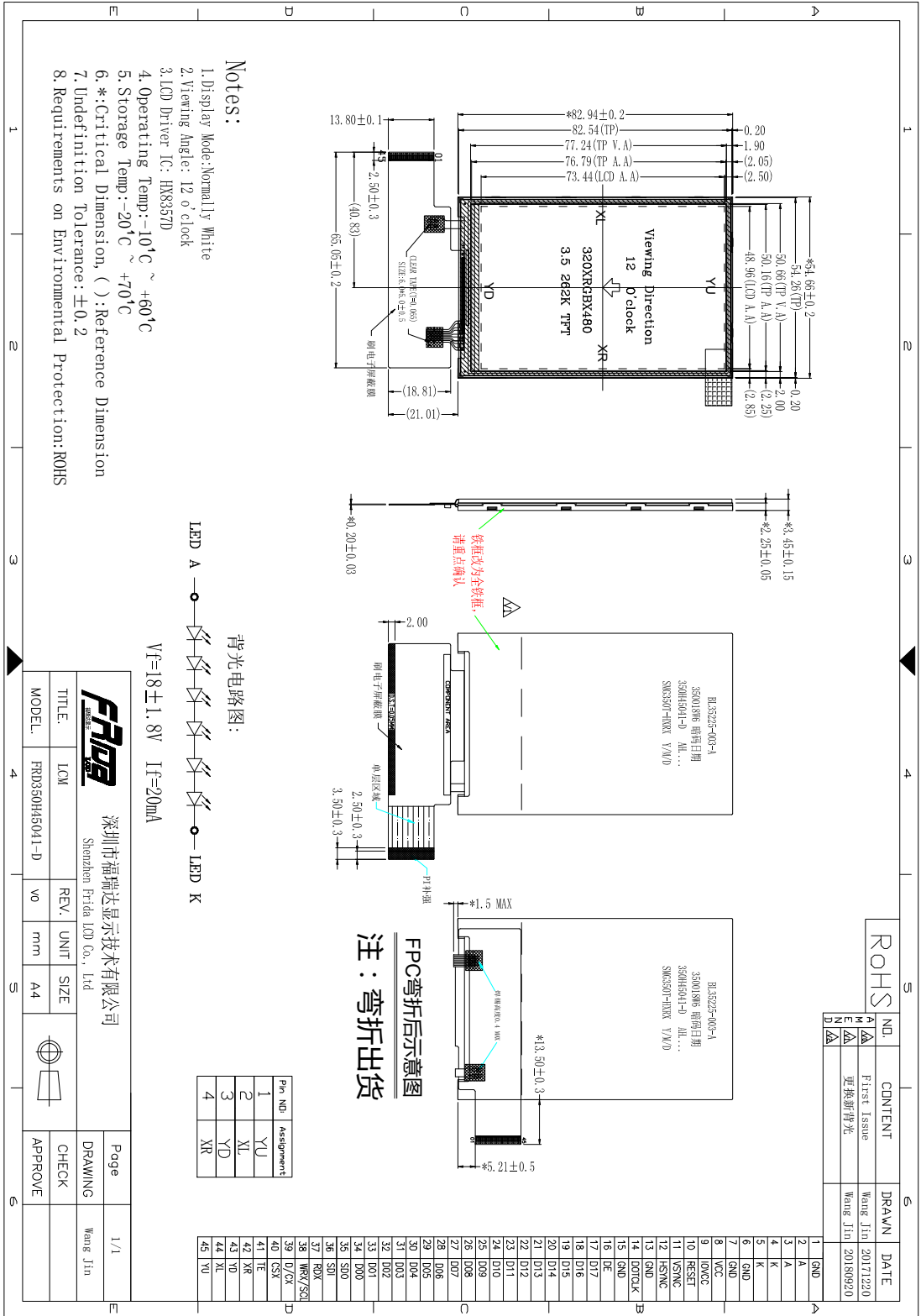



4. Interface Specification

Pin No	Symbol	Description	Note
1	GND	Ground	
2~3	A	Power Supply For LED Backlight Anode Input.	
4~5	K	Power Supply For LED Backlight Cathode Input.	
6~7	GND	Ground	
8	VCC	Power Supply For LCD.	
9	IOVCC	Power Supply For I/O.	
10	RESET	Reset Signal input pin.	
11	VSYNC	Frame synchronous signal for RGB interface operation.	
12	HSYNC	Line synchronous signal for RGB interface operation.	
13	GND	Ground	
14	DOTCLK	Dot clock signal for RGB interface operation.	
15	GND	Ground	
16	DE	Data enable signal for RGB interface operation.	
17-22	DB17-DB12	Red data (DB12-LSB;DB17-MSB)	
23-28	DB11-DB6	Green data (DB6-LSB; DB11-MSB)	
29-34	DB5-DB0	Blue data (DB0-LSB;DB5-MSB)	
35	SDO	Serial data input pin..	
36	SDI	Serial data output pin.	
37	RDX	Read strobe signal.	
38	WRX/SCL	Serial clock signal pin.	
39	D/CX	In 4SPI : Data / Command Selection pin.	Note1
40	CSX	Chip selection signal pin.	
41	TE	Frame head pulse for tearing effect.	
42	XR	touch panel. RIGHT.	
43	YD	touch panel. DOWN.	
44	XL	touch panel. Left.	
45	YU	touch panel. UP.	



Note1

R2	R1	Interface	Using function pins	NOTE
open	贴片0 OHM	3SPI+RGB18	RESET, DB17~DB0, WRX/SCL, SDI, SDO, CSX, VSYNC, HSYNC, DOTCLK, DE	default
贴片0 OHM	open	4SPI+RGB18	RESET, DB17~DB0, WRX/SCL, SDI, SDO, CSX, D/CX, VSYNC, HSYNC, DOTCLK, DE	

5. Absolute Maximum Ratings

Electrical Maximum Ratings – for IC Only

Parameter	Symbol	Min.	Max.	Unit	Note
Power supply voltage (VCC)	VCC	-0.3	+4.6	V	1
Power supply voltage (IOVCC)	IOVCC	-0.3	+4.6	V	1

Note:

1. IOVCC, VCC, GND must be maintained.
2. The modules may be destroyed if they are used beyond the absolute maximum ratings.

6. Electrical Specifications

At Ta = 25 °C, VCC = 2.5V to 3.3V, IOVCC= 1.65V to 3.3V GND=0V.

Parameter	Symbol	Conditions	Min.	Typ.	Max.	Unit
Supply voltage (analog)	VCC-GND		2.5	2.8	3.3	V
Supply voltage (logic)	IOVCC-GND		1.65	1.8	3.3	V
Supply current (Logic & LCD)	ICC	-	-	-	TBD	mA
Supply voltage of white LED backlight	VLED	Forward current =20mA Number of LED = 6	17.2	18.0	19.8	V

7. Timing Characteristics

7.1 DBI Type C Option 1 (3-Line SPI System) Timing Characteristics

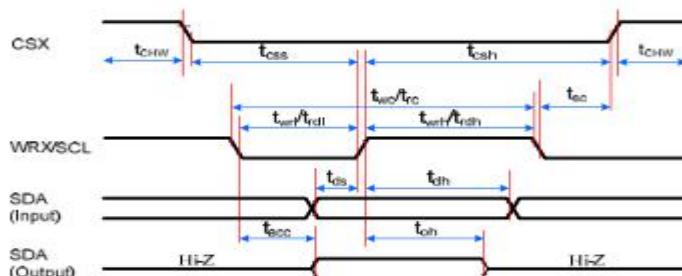

Signal	Symbol	Parameter	min	max	Unit	Description
CSX	tsc	SCL-CSX	15	-	ns	
	tchwh	CSX H Pulse Width	40	-	ns	
	tcss	Chip select time (Write)	60	-	ns	
	tcsh	Chip select hold time (Read)	65	-	ns	
SCL	twc	Serial Clock Cycle (Write)	66	-	ns	
	twrh	SCL H Pulse Width (Write)	15	-	ns	
	twrL	SCL L Pulse Width (Write)	15	-	ns	
	trc	Serial Clock Cycle (Read)	150	-	ns	
	trdh	SCL H Pulse Width (Read)	60	-	ns	
	trdL	SCL L Pulse Width (Read)	60	-	ns	
SDA (Input)	tds	Data setup time (Write)	10	-	ns	
	tdh	Data hold time (Write)	10	-	ns	
SDA/SDO (Output)	taoc	Access time (Read)	10	50	ns	For maximum CL=30pF
	tsh	Output disable time (Read)	15	50	ns	For minimum CL=8pF

Note: Ta = -30 to 70 °C, IOVCC = 1.65V to 3.6V, VCI = 2.5V to 3.6V, AGND = DGND = 0V, T = 10+/-0.5ns

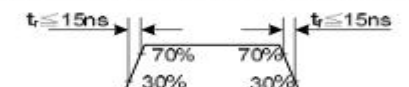

7.2 DPI (Display Parallel 16-/18-/24-bit interface) Timing Characteristics

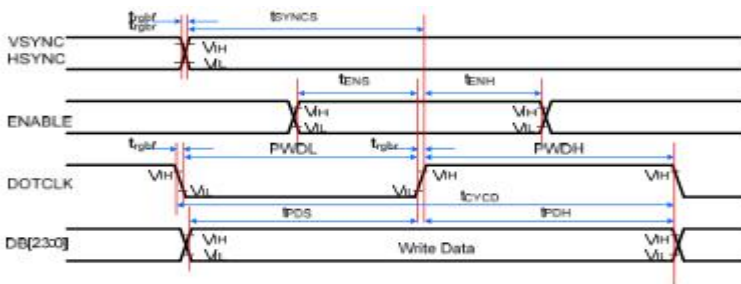

Signal	Symbol	Parameter	min	max	Unit	Description
VSYNC/HSYNC	tVSYNC	VSYNC/HSYNC setup time	15	-	ns	16-/18-/24-bit bus RGB interface mode
	tVSHD	VSYNC/HSYNC hold time	15	-	ns	
ENABLE	tENS	ENABLE setup time	15	-	ns	
	tENH	ENABLE hold time	15	-	ns	
DB [23:0]	tDSS	Data setup time	15	-	ns	
	tDSH	Data hold time	15	-	ns	
DOTCLK	PWDH	DOTCLK high-level period	20	-	ns	
	PWDL	DOTCLK low-level period	20	-	ns	
	tDOTC	DOTCLK cycle time	50	-	ns	
	tDOTC_rise_fall	DOTCLK_HSYNC, VSYNC rise/fall time	-	15	ns	

Note: Ta = -30 to 70 °C, IOVCC = 1.65V to 3.3V, VCI = 2.5V to 3.3V, AGND = DGND = 0V

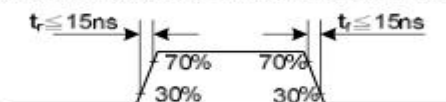

8.Power Supply Configuration

IOVCC and VCI can be applied or powered down in any order. During the Power Off sequence, if the LCD is in the Sleep Out mode, VCI and IOVCC must be powered down with a minimum of 120msec. If the LCD is in the Sleep In mode, VCI and IOVCC can be powered down with a minimum of 0msec after the RESX has been released. CSX can be applied at any time or can be permanently grounded. RESX has high priority over CSX.

Notes:

1. There will be no damage to the ILI9488 if the power sequences are not met.
2. There will be no abnormal visible effects on the display panel during the Power On/Off Sequence.
3. There will be no abnormal visible effects on the display between the end of the Power On Sequence and before receiving the Sleep Out command, and also between receiving the Sleep In command and the Power Off Sequence.
4. If the RESX line is not steadily held by the host during the Power On Sequence as defined in Sections 11.1 and 11.2, then it will be necessary to apply the Hardware Reset (RESX) after the completion of the Host Power On Sequence to ensure correct operations. Otherwise, all the functions are not guaranteed.
5. When the power is turned on, the climb period timing(T_{rise}) must be greater than 10us.
6. Keep data pins DB[23:0] at low level, when VCI or IOVCC comes later

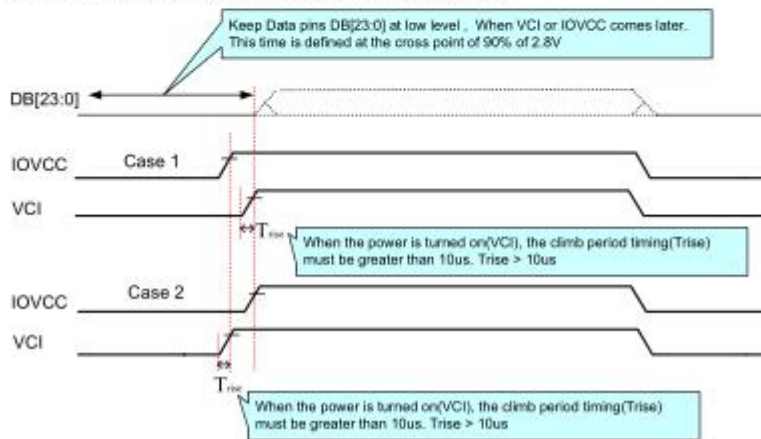

8.1 Case 1 - RESX Line is Held High or Unstable by Host at Power ON

If the RESX line is held High or unstable by the host during Power On, then Hardware Reset must be applied after both VCI and IOVCC have been applied. Otherwise, the correct functionality is not guaranteed. There is no timing restriction upon this hardware reset.

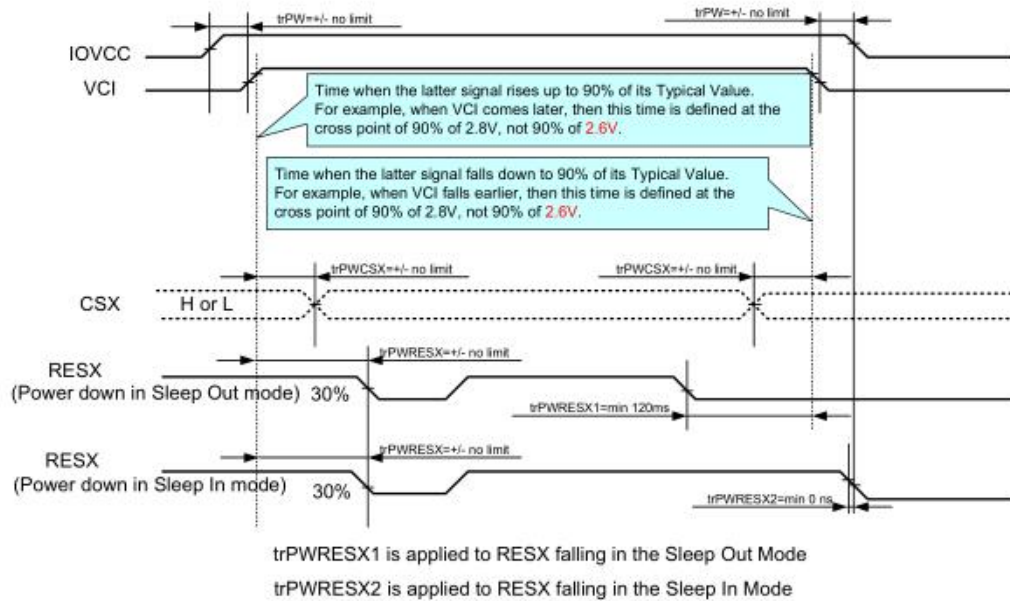

Note: Unless otherwise specified, timings herein show the cross point at 50% of the signal power level.

8.2 Case 2 - RESX Line is Held Low by Host at Power ON

If the RESX line is held Low (and stable) by the host during Power On, then the RESX must be held low for a minimum of 10µsec after both VCI and IOVCC have been applied.

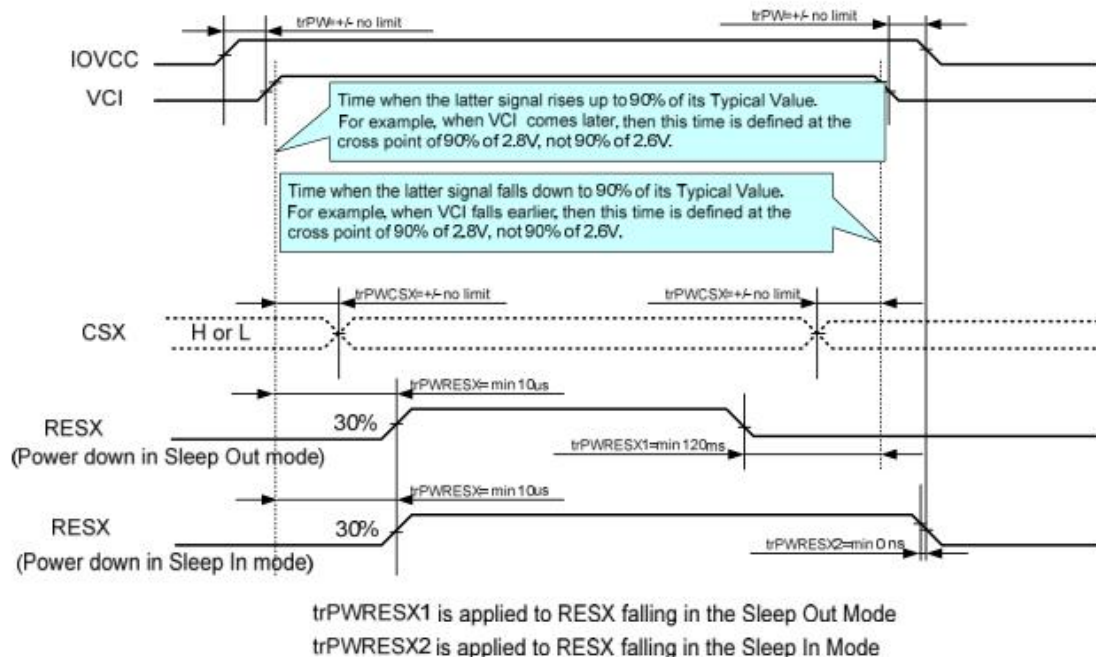



9.Optical Specification

Item 项目	Symbol 符号	Condition 条件	Min 最小值	Typ 典型值	Max 最大值	Unit 单位	Note 备注
Response time 响应时间	Tr+Tf	$\Theta=0^{\circ}$ $\emptyset=0^{\circ}$ $T_a=25^{\circ}\text{C}$	-	16	32	ms	1
Contrast ratio 对比度	Cr		400	500	-	-	2
Color gamut 饱和度	S(%)		54	60	-	%	-
Luminance uniformity 均匀度	δ WHITE		80	-	-	%	3
Viewing angle range 视角范围	Θ_{x+}	$CR \geq 10$ $T_a=25^{\circ}\text{C}$	60	70	-	deg	4
	Θ_{x-}		60	70	-	deg	
	Θ_{y+}		60	70	-	deg	
	Θ_{y-}		40	60	-	deg	
LCM Luminance LCM 亮度	Lv	$\Theta=0^{\circ}$ $\emptyset=0^{\circ}$ $T_a=25^{\circ}\text{C}$	-	280	-	Cd/m ²	5
CIE (X,Y) Chromaticity 色度坐标	White(X)		0.26	0.29	0.32	-	6
	White(Y)		0.28	0.31	0.34	-	

Note1.Response time is the time required for the display to transition from White to black(Rise Time,Tr)and from black to white(Decay Time,Tf).For additional information see FIG1...

Note2.contrast Ratio(CR) is defined mathematically by the following formula ,For more information see FIG2.

Contrast Ratio(CR)=Average Surface Luminance with all white pixels/ Average Surface Luminance with all black pixels

Note3.The uniformity in surface luminance(WHITE) is determined by measuring luminance at each test position,and then dividing the maximum luminance of all white pixels by minimum luminance of all white pixels,For more information seeFIG2.

WHITE=Minimum Surface Luminance with all white pixels(P1,P2,.....)/Maximum Surface

Luminance with all white pixels(P1,P2,.....)

Note4.Viewing angle is the angel at which contrast ratio is greater than a specific value.For TET module,the specific value of contrast ratio is 10.For monochrome and color stn module,the specific value of contrast ratio is2.The angles are determined for the horizontal or x axis and the vertical or y axis with respect to the z axis which is normal to the LCD surface.For more information see FIG3

Note5. Surface luminance is the LCD surface luminance with all white pixels,For more information see FIG2.

LV=Average Surface Luminance with all white pixels(P1,P2,.....)

Note6.CIE(X,Y)chromaticity is the Center point value.For more information see FIG2.

Note7.For Viewing angle and response time testing,the testing date is base on Autronic-Melchers' s ConScope.Series instruments.For contrast ratio,Surface Luminance,Luminance uniformity and CIE,the testing date is base on CS-2000 photo detector.

Note8.For TN type TFT transmissive module,Gray scale reverse occurs in the direction of panel viewing angle

FIG1. The definition of Response time

响应时间定义

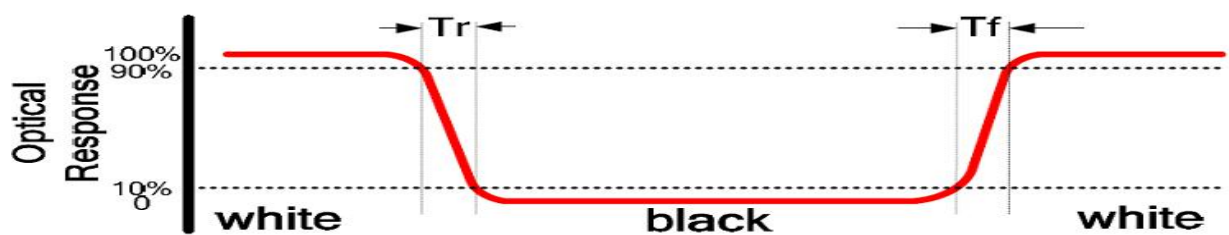

FIG2. Measuring method for Contrast ratio,surface luminance,Luminance uniformity,CIE(X,Y)chromaticity.

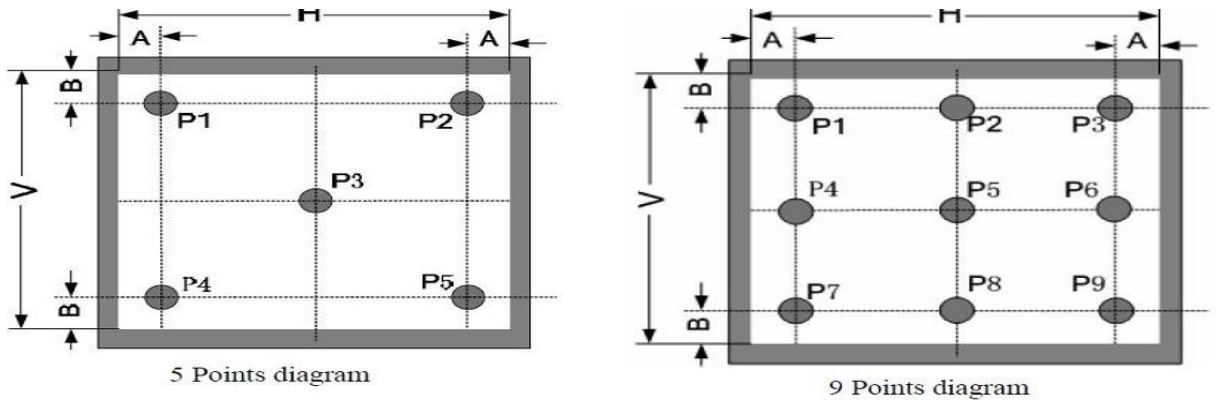
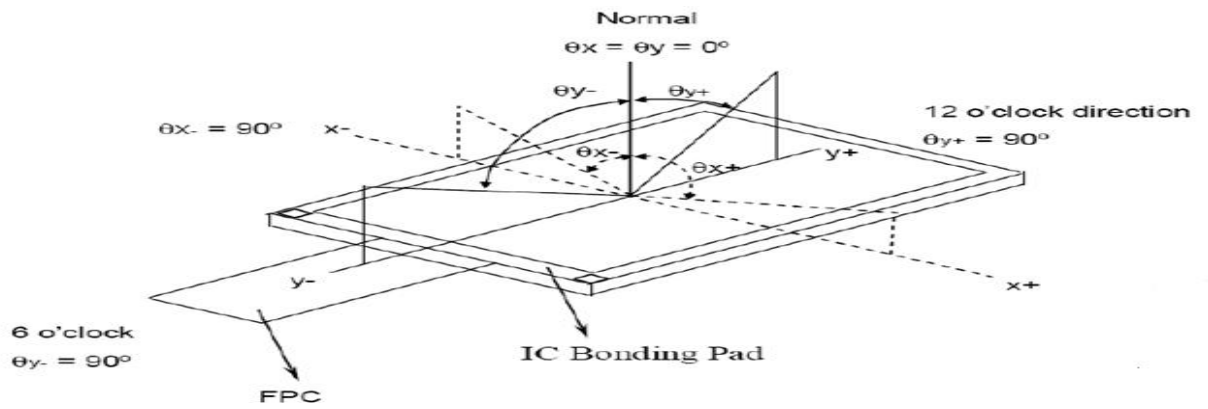

FIG3 The definition of viewing angle 视角定义





10. Reliability Test Items

Item	Test Condition	Criterion
High Temperature Storage	70 °C, 48 hrs	Note1,Note2
Low Temperature Storage	-20 °C, 48 hrs	
High Temp. & High Humidity Storage	40 °C, 80% RH, 48hrs	
Thermal Shock (Static)	-20°C, 30 min /70°C, 30 min, 20 cycles	
High Temperature Operation	60 °C, 48 hrs	
Low temperature Operation	-10 °C, 48 hrs	

Note1: Evaluation should be tested after storage at room temperature for two hours.

Note2:

Pass: Normal display image no line defect.

Fail: No display image, or line defects.

Partial transformation of the module parts should be ignored.

11. Precautions

Please pay attentions to the followings as using the LCD module.

Handling

- (a) Do not apply strong mechanical stress like drop, shock or any force to LCD module. It may cause improper operation, even damage.
- (b) Because the polarizer is very fragile and easy to be damaged, do not hit, press or rub the display surface with hard materials.
- (c) Do not put heavy or hard material on the display surface, and do not stack LCD modules.
- (d) If the display surface is dirty, please wipe the surface softly with cotton swab or clean cloth.



- (e) Avoid using Ketone type materials (e.g. Acetone), Toluene, Ethyl acid or Methyl chloride to clean the display surface. It might damage the touch panel surface permanently. The recommended solvents are water and Isopropyl alcohol.
- (f) Wipe off water droplets or oil immediately.
- (g) Protect the LCD module from ESD. It will damage the LSI and the electronic circuit.
- (h) Do not touch the output pins directly with bare hands.
- (i) Do not disassemble the LCD module.
- (j) Do not lift the FPC of Touch Panel.

Storage

- (a) Do not leave the LCD modules in high temperature, especially in high humidity for a long time.
- (b) Do not expose the LCD modules to sunlight directly.
- (c) The liquid crystal is deteriorated by ultraviolet. Do not leave it in strong ultraviolet ray for a long time.
- (d) Avoid condensation of water. It may cause improper operation.
- (e) Please stack only up to the number stated on carton box for storage and transportation. Excessive weight will cause deformation and damage of carton box.

Operation

- (a) When mounting or dismounting the LCD modules, turn the power off.
- (b) Protect the LCD modules from electric shock.
- (c) The Driver IC control algorithms stated above should always obeyed to avoid damaging the LSI and electronic circuit.
- (d) Be careful to avoid mixing up the polarity of power supply for backlight.
- (e) Absolute maximum rating specified above has to be always kept in any case. Exceeding it may cause non-recoverable damage of electronic components or, nevertheless, burning.
- (f) When a static image is displayed for a long time, remnant image is likely to occur.
- (g) Be sure to avoid bending the FPC to an acute shape, it might break FPC.
- (h) Most of the touch screens have air vent to equalize the inside air pressure to the outside one. The air vent must be open and liquid contact must be avoided as the liquid may be

absorbed if the liquid is accumulated near the air vent.

- (i) For the fragility of ITO film, it should avoid to use too tapering pen as the input material.

Touch Panel Mounting Notes

- (a) If a cushion is used between bezel/housing and film must be choose as free as enough to absorb the expansion and contraction to avoid the distortion of film.
- (b) The cushion must be placed out of the Viewing Area.
- (c) Bezel/Housing edge must be posited between Key Area and Viewing Area. The edge enters the Key Area may cause unexpected input if the gap is too narrow or foreign particles like dusts exist between Bezel/Housing and ITO film.
- (d) Mounting example:

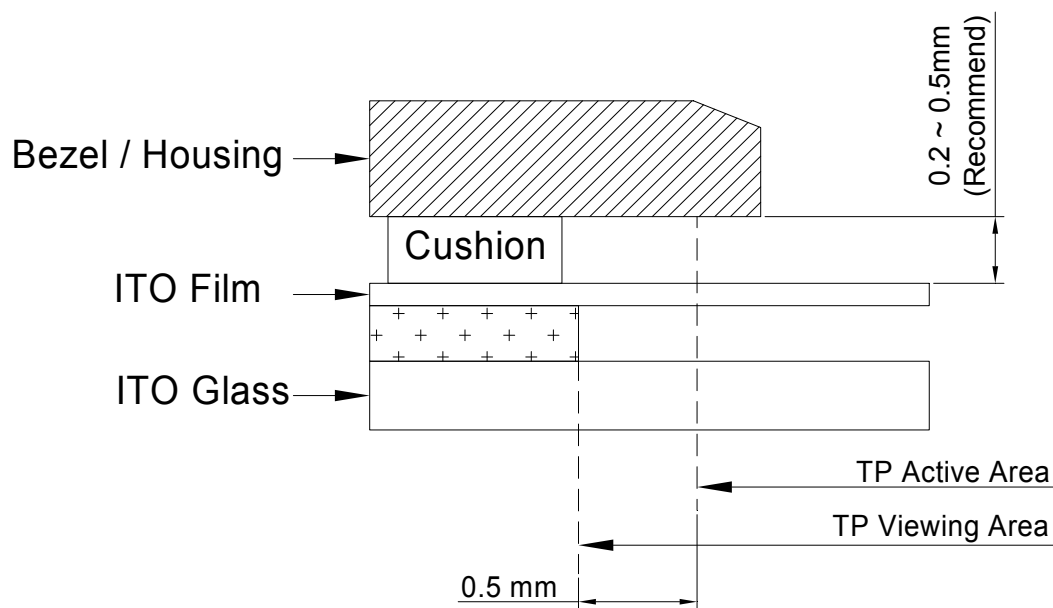

The corner part has conductivity. Do not touch any metal part after mounting.

Others

- a) If the liquid crystal leaks from the panel, it should be kept away from the eyes or mouth.
- b) For the fragility of polarizer, it is recommended to attach a transparent protective plate over the display surface.
- c) It is recommended to peel off the protection film on the polarizer slowly so that the electrostatic charge can be minimized.