

REV	DESCRIPTION	DATE	REVISER
V1.0	First issue	2016.03.22	

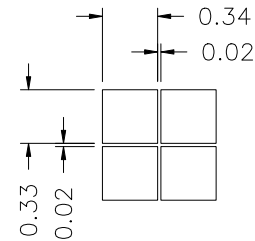
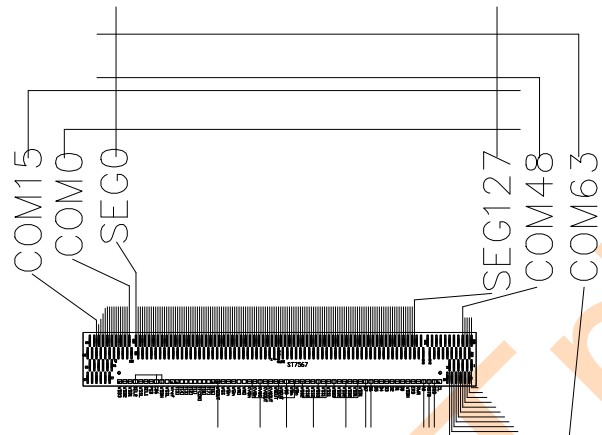
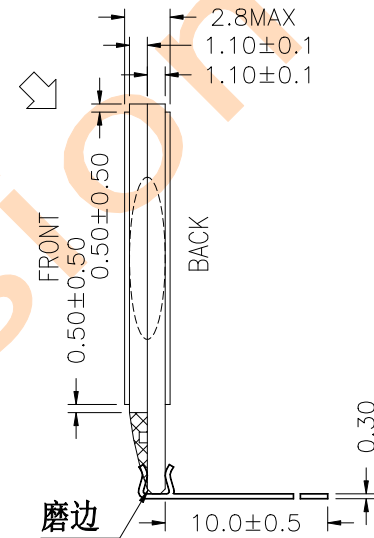
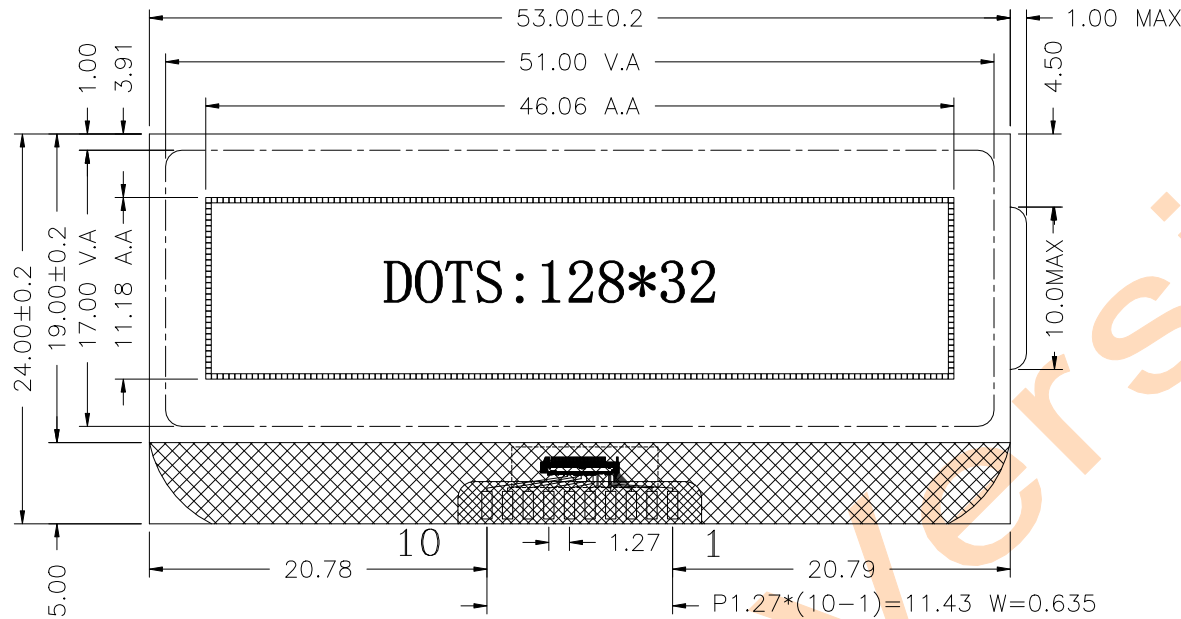

PIN	SYMBOL
1	CSB
2	RSTB
3	A0
4	SCL
5	SDA
6	VDD
7	VSS
8	V0
9	XV0
10	VG

CONFORM TO ROHS STANDARD

Shenzhen Frida LCD Co., Ltd

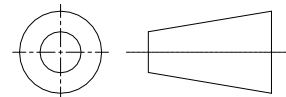

OPERATING VOLTAGE: 3.0V	VIEW DIRECTION: 12:00 O' CLOCK
DISPLAY TYPE: STN(BLUE), NEGATIVE, TRANSMISSIVE	LCD CONTROLLER: ST7567
LCD DRIVE METHOD: 1/33 DUTY 1/6 BIAS 5.0V	BACK LIGHT: ---
OPERATING TEMPERATURE: 0°C TO 50°C	STORAGE TEMPERATURE: -10°C TO 60°C
*:Key dimension, (---): Reference dimension	DEFAULT TOLERANCE: ± 0.2

TITLE	模组外形图	CUSTOMER NUMBER		REV	V1.0
DES'D BY		PRODUCT MODEL	GHG12832A12	UNIT	mm
CHK'D BY		LCD NUMBER	GH81830SNTP-P3	DATE	2016-03-22
APPROVED		SCALE	1:1	NO.	1/1