

COUNT	DESCRIPTION OF REVISIONS	BY	CHKD	DATE	COUNT	DESCRIPTION OF REVISIONS	BY	CHKD	DATE
16	RE-H-03128(C)	S.H	K.A	97.5.31					

HRA NO.	PART NO.	NUMBER OF CONTACT	A	B	C
CL543-0179-4	DF3A-2P-2DS	2	6.0	4.6	2.0
CL543-0180-3	DF3A-3P-2DS	3	8.0	6.6	4.0
CL543-0181-6	DF3A-4P-2DS	4	10.0	8.6	6.0
CL543-0182-9	DF3A-5P-2DS	5	12.0	10.6	8.0
CL543-0183-1	DF3A-6P-2DS	6	14.0	12.6	10.0
CL543-0184-4	DF3A-7P-2DS	7	16.0	14.6	12.0
CL543-0185-7	DF3A-8P-2DS	8	18.0	16.6	14.0
CL543-0186-0	DF3A-9P-2DS	9	20.0	18.6	16.0
CL543-0187-2	DF3A-10P-2DS	10	22.0	20.6	18.0
CL543-0188-5	DF3A-11P-2DS	11	24.0	22.6	20.0
CL543-0189-8	DF3A-12P-2DS	12	26.0	24.6	22.0
CL543-0190-7	DF3A-13P-2DS	13	28.0	26.6	24.0
CL543-0191-0	DF3A-14P-2DS	14	30.0	28.6	26.0
CL543-0192-2	DF3A-15P-2DS	15	32.0	30.6	28.0

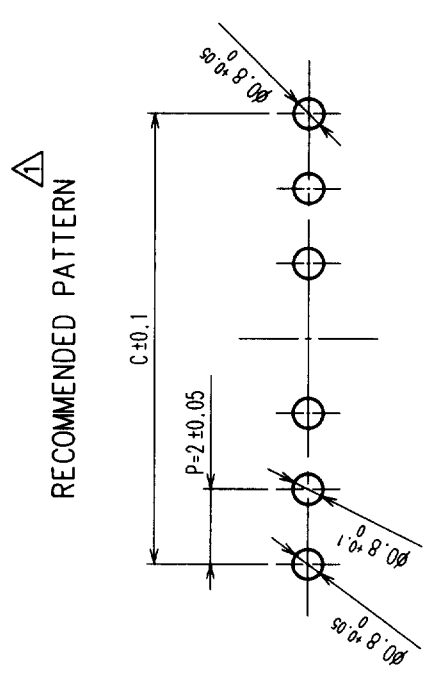
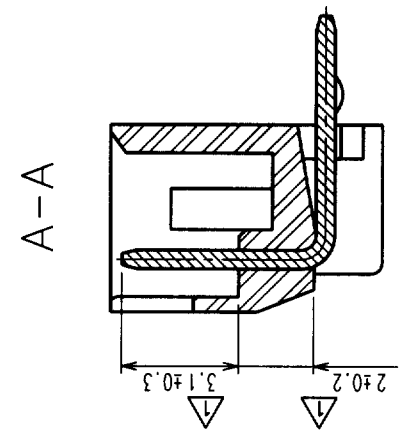
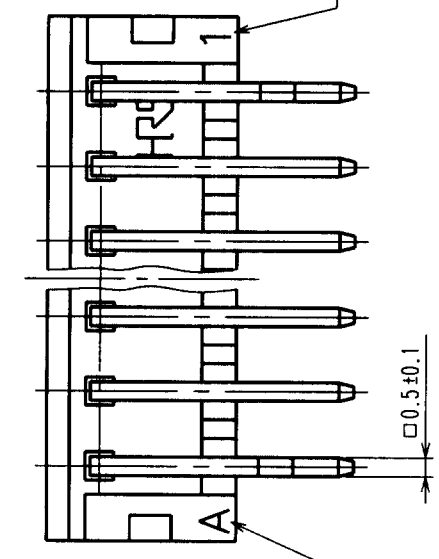
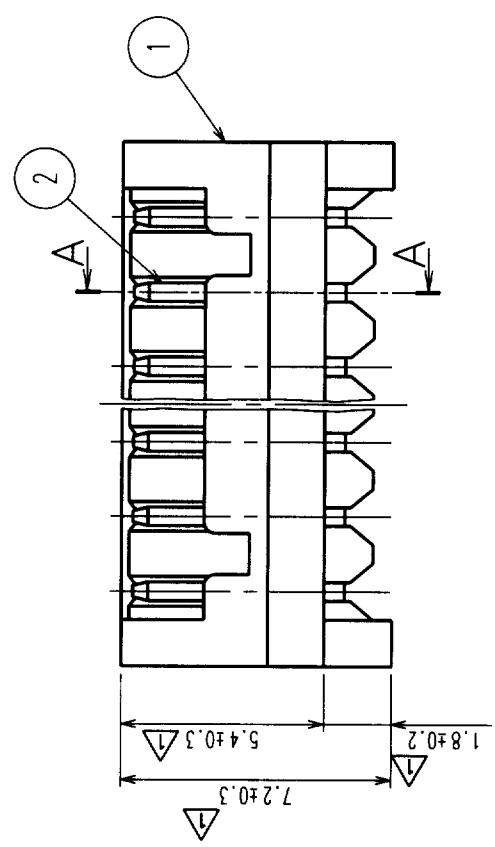
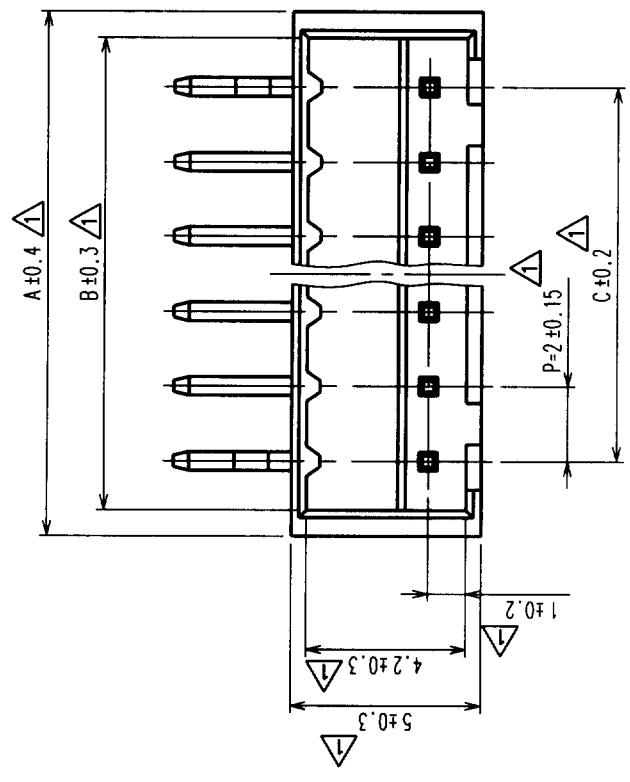

NOTES: No. 1 AND * CONTACT SHALL BE PROCESSED KINK. (*=2-15)

NO.	MATERIAL	FINISH, REMARKS	NO.	MATERIAL	FINISH, REMARKS
1	POLYAMIDE	BLACK, UL94V-0	2	BRASS	TIN PLATING

CODE NO. (OLD)	DRAWN	DESIGNED	CHECKED	APPROVED	RELEASED
	H. Igarashi	H. Igarashi	T. Oma	M. Yamamoto	
	'94. 3. 29	'94. 3. 29	'94. 3. 29	'94. 3. 29	

DRAWING NO.	PART NO.
EDC3-160110-01	DF3A-*P-2DS

SCALE	UNITS	ITEM
5 : 1	MM	1

TO	
----	--