

Mar.1.2020 Copyright 2020 HIROSE ELECTRIC CO., LTD. All Rights Reserved.  
In case of consideration for using Automotive equipment / device which demand high reliability, kindly contact our sales window correspondents.

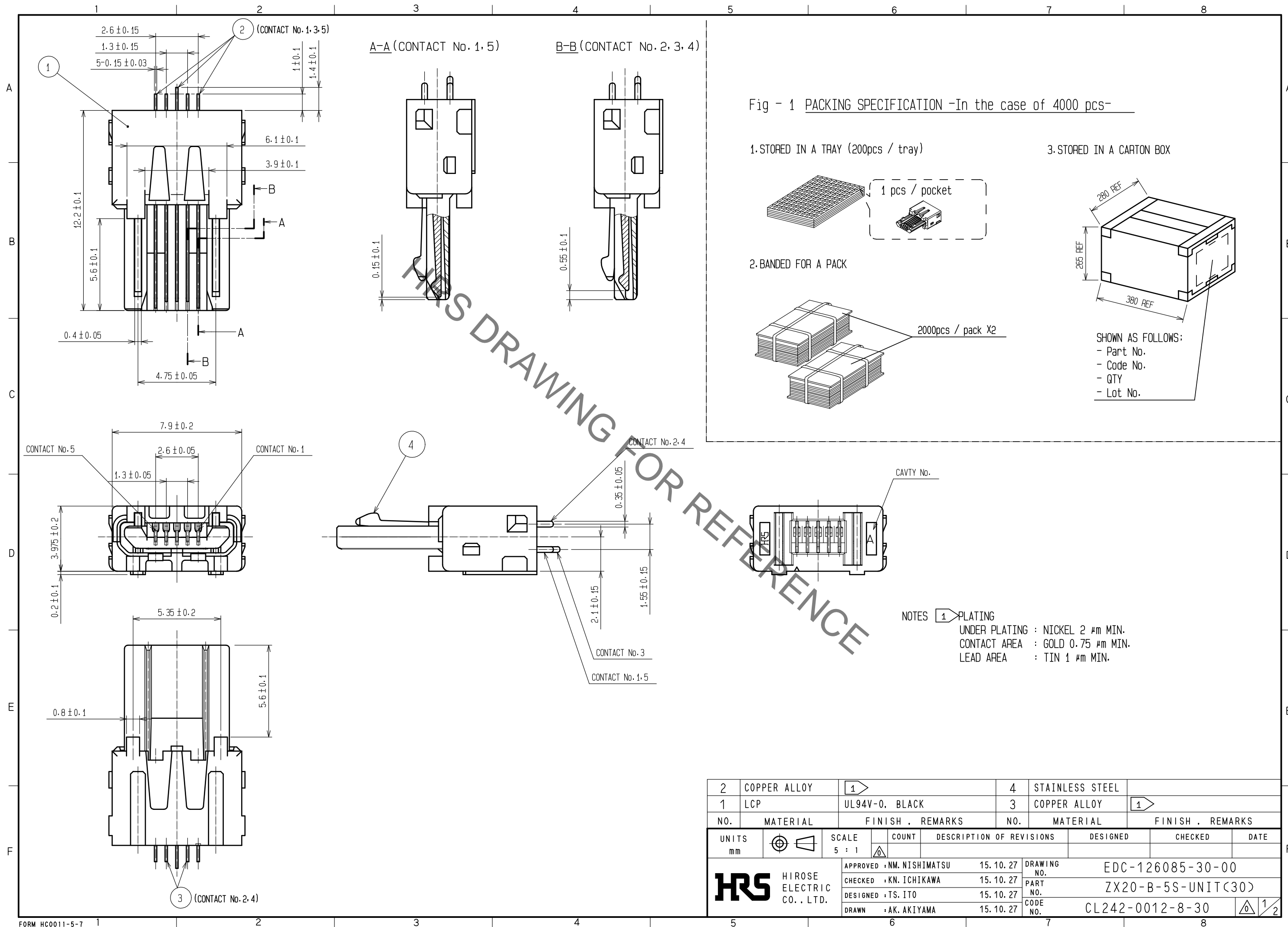

Mar.1.2020 Copyright 2020 HIROSE ELECTRIC CO., LTD. All Rights Reserved.  
In case of consideration for using Automotive equipment / device which demand high reliability, kindly contact our sales window correspondents.

2 Fig-2 SHIELDING-PLATE ASSEMBLY

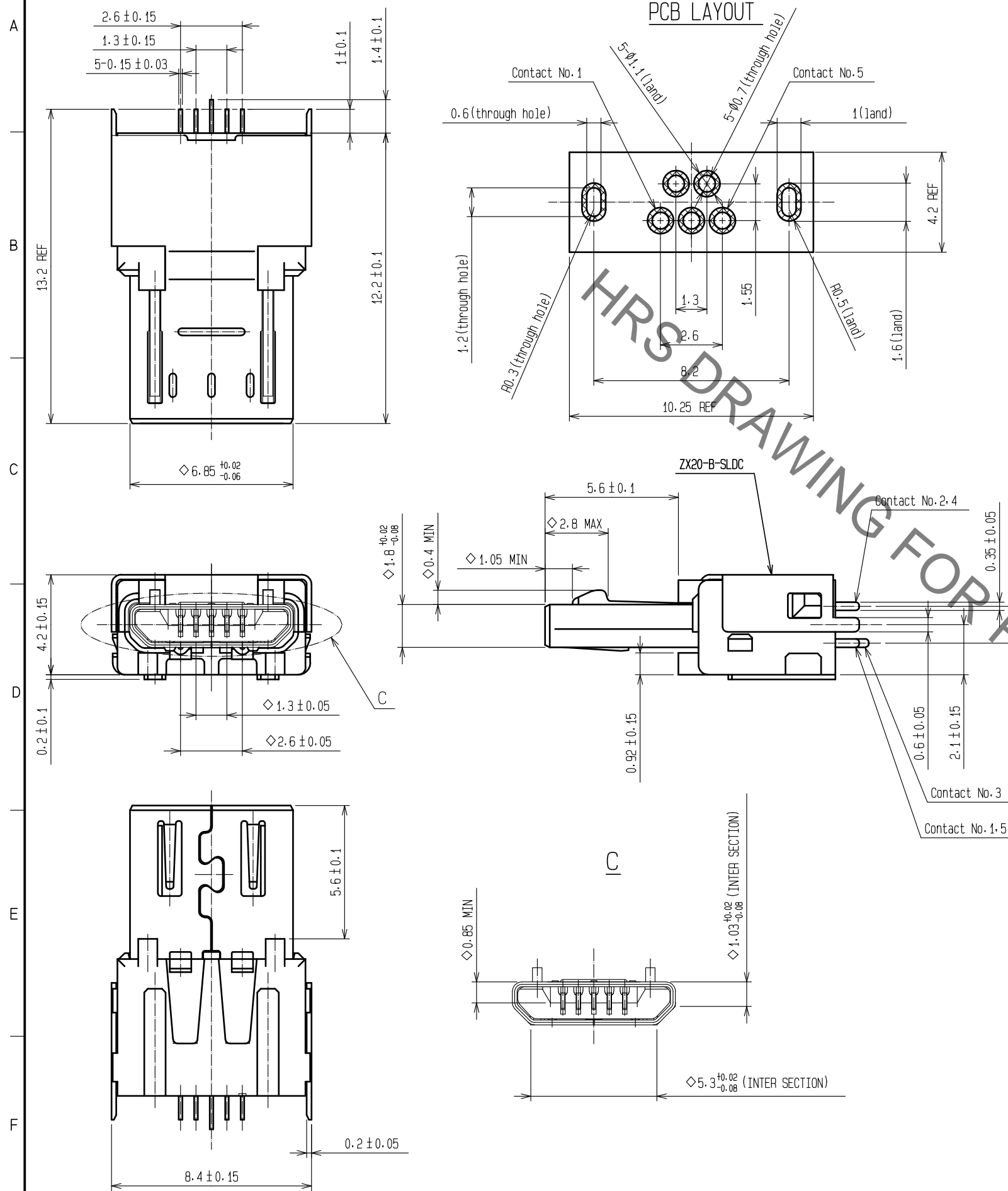
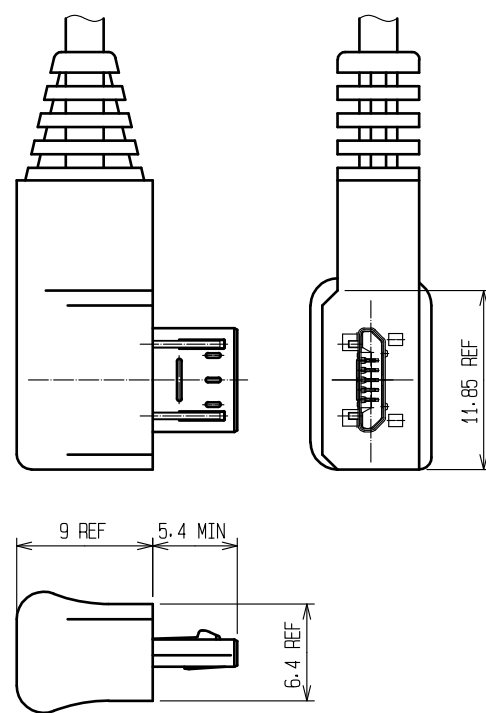
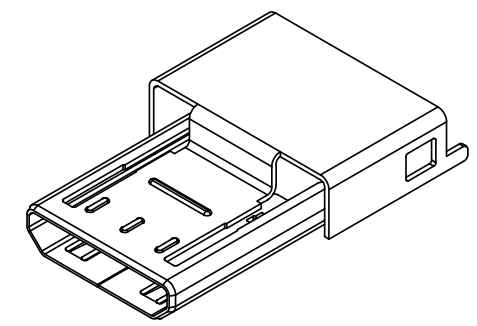

Fig-3 OVER-MOLDING(REFERENCE)



2 ZX20-B-SLDC  
Code No. CL242-0022-1



NOTE:  
- SOLD SEPARATELY  
- DELIVERED BY THE REEL

Fig-4 MATED CONDITION

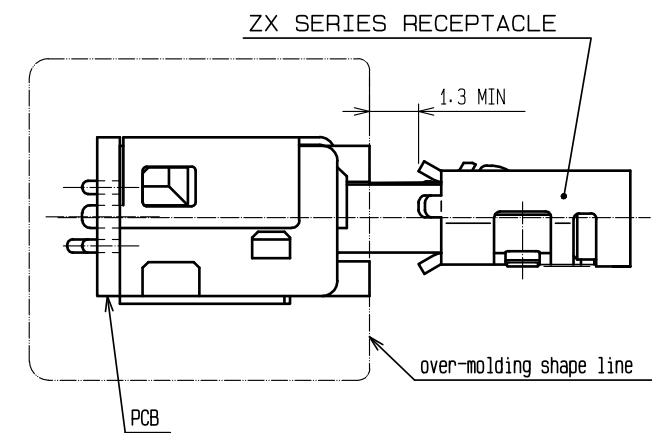

NOTES 2 SHIELDING-PLATE, ZX20-B-SLDC, IS USED FOR ASSEMBLY.

3. \*◇\*SYMBOL ADDED TO EACH DIMENSION MEANS CRITICAL DIMENSION ON USB SPECIFICATION. PLEASE CHECK THEM AFTER OVER-MOLDING.

<b>HRS</b>	DRAWING NO.	EDC-126085-30-00
	PART NO.	ZX20-B-5S-UNIT<30>
	CODE NO.	CL242-0012-8-30
		2/2