

MODEL NO : TM104SDH01**MODEL VERSION:** 40**SPEC VERSION :** 1.0**ISSUED DATE:** 2020-10-22

- Preliminary Specification
 Final Product Specification

Customer : _____

Approved by	Notes

TIANMA Confirmed :

Prepared by	Checked by	Approved by
Chunhui Yang	Longping Deng	Feng.Qin

This technical specification is subjected to change without notice

Table of Contents

Table of Contents	2
Record of Revision.....	3
1 General Specifications.....	4
2 Input/Output Terminals	5
3 Absolute Maximum Ratings.....	6
4 Electrical Characteristics	7
5 Timing Chart.....	10
6 Optical Characteristics	13
7 Environmental / Reliability Test.....	16
8 Mechanical Drawing	17
9 Packing Drawing	19
10 Precautions for Use of LCD Modules.....	20

Record of Revision

Rev	Issued Date	Description	Editor
1.0	2020-10-22	Final spec release	Chunhui Yang

1 General Specifications

	Feature	Spec
Display Spec.	Size	10.4 inch
	Resolution	800(RGB) x 600
	Technology Type	a-Si
	Pixel Configuration	R.G.B. Vertical Stripe
	Pixel pitch(mm)	0.264x0.264
	Display Mode	TM with Normally White
	Surface Treatment	Anti-Glare(3H)
	Viewing Direction	12 o'clock
	Gray Scale Inversion Direction	6 o'clock
Mechanical Characteristics	LCM (W x H x D) (mm)	236.00x176.90x5.60
	Active Area(mm)	211.20x158.40
	With /Without TSP	Without TSP
	Matching Connection Type	CN1:HIROSE DF19K-20P-1H CN2:JST BHSR-02VS-1
	LED Numbers	36 LEDS
	Weight (g)	288
Electrical Characteristics	Interface	LVDS 6 bits
	Color Depth	262K
	Driver IC	NT39411DH-D*2+ NT39211H-D*1

Note 1: Viewing direction for best image quality is different from TFT definition. There is a 180 degree shift.

Note 2: Requirements on Environmental Protection: Q/S0002

Note 3: LCM weight tolerance: $\pm 5\%$

2 Input/Output Terminals

2.1 CN1 TFT LCD Panel

Matched Connector: HIROSE DF19K-20P-1H

Pin No.	Symbol	I/O	Function	Remark
1	VDD	P	Power Supply	
2	VDD	P	Power Supply	
3	GND	P	Ground	
4	GND	P	Ground	
5	IN0-	I	LVDS receiver negative signal channel 0	
6	IN0+	I	LVDS receiver positive signal channel 0	
7	GND	P	Ground	
8	IN1-	I	LVDS receiver negative signal channel 1	
9	IN1+	I	LVDS receiver positive signal channel 1	
10	GND	P	Ground	
11	IN2-	I	LVDS receiver negative signal channel 2	
12	IN2+	I	LVDS receiver positive signal channel 2	
13	GND	P	Ground	
14	CLK-	I	LVDS receiver negative signal clock	
15	CLK+	I	LVDS receiver positive signal clock	
16	GND	P	Ground	
17	NC	-	No connection	
18	NC	-	No connection	
19	GND	P	Ground	
20	GND	P	Ground	

Note: I/O definition:

I----Input O---Output P----Power/Ground

2.2 CN2(BackLight Connector)

Matched Connector: JST BHSR-02VS-1

No	Symbol	I/O	Description	Wire Color
1	LEDA	P	LED driving anode (high voltage)	Red
2	LEDK	P	LED driving cathode (low voltage)	White

3 Absolute Maximum Ratings

GND=0V

Item	Symbol	MIN	MAX	Unit	Remark
Power Voltage	VCC	-0.3	5.0	V	Note1
Input voltage	V _{IN}	-0.3	5.0	V	
Operating Temperature	Top	-20	70	°C	
Storage Temperature	Tst	-30	80	°C	
Relative Humidity Note2	RH	--	≤95	%	Ta≤40°C
		--	≤85	%	40°C < Ta ≤ 50°C
		--	≤55	%	50°C < Ta ≤ 60°C
		--	≤36	%	60°C < Ta ≤ 70°C
		--	≤24	%	70°C < Ta ≤ 80°C
Absolute Humidity	AH	--	≤70	g/m ³	Ta>70°C

Table 3 Absolute Maximum Ratings

Note1: Input voltage include IN0-/IN0+, IN1-/IN1+, IN1-/IN1+, CLK-/CLK+.

Note2: Ta means the ambient temperature.

It is necessary to limit the relative humidity to the specified temperature range.
Condensation on the module is not allowed.

4 Electrical Characteristics

4.1 Driving TFT LCD Panel

GND=0V, Ta=25°C

Item	Symbol	Min	Typ	Max	Unit	Remark
LVDS Differential input high threshold	V_{TH}	-	-	+100	mV	$V_{CMLVDS}=1.2V$
LVDS Differential input low threshold	V_{TL}	-100	-	-	mV	$V_{CMLVDS}=1.2V$
Differential input voltage	$ V_{ID} $	0.1	-	0.6	V	
LVDS input common mode voltage	V_{CMLVDS}	$ V_{ID} /2$	-	$1.4-(V_{ID} /2)$	V	
Supply Voltage	VDD	3.0	3.3	3.6	V	
VDD rush current	I_{rush}	-	-	1.5	A	VDD rising time 0.5ms
VDD Power Consumption	I_{DD}	-	260	380	mA	Note1

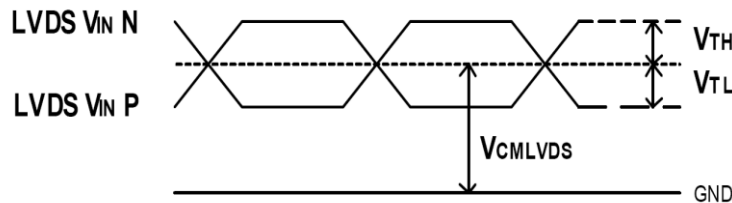

Figure 4.1.1 LVDS DC timing diagram

4.2 Driving Backlight

 $T_a=25^{\circ}\text{C}$

Item	Symb ol	Min	Typ	Max	Unit	Remark	
Forward Current	I_F		120.0	180	mA	Note 1	
Forward Current Voltage	V_F	18.0	19.2	21.6	V	Note 1	
Backlight Power Consumption	WBL	-	2304	3888	mW	Note 1	
Operating Life Time	--	--	30000	--	hrs	Note 2	

Note 1: The figure below shows the connection of backlight LED.

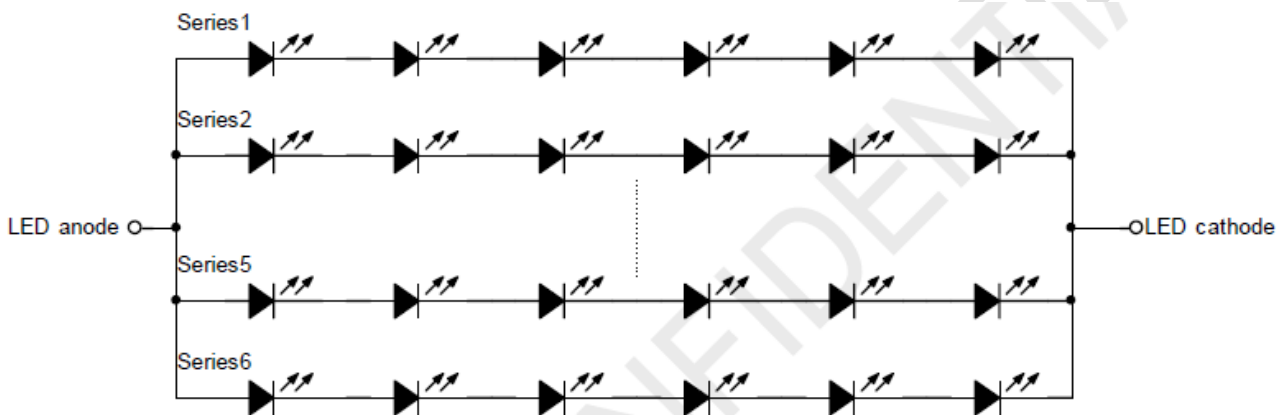

Figure 4.2 LED connection of backlight

Note 2: I_F is defined for six channels.

Optical performance should be evaluated at $T_a=25^{\circ}\text{C}$ only.

If LED is driven by high current, high ambient temperature & humidity condition.

The life time of LED will be reduced.

Operating life means brightness goes down to 50% initial brightness.

Typical operating life time is estimated data.

Note3:One channel: $I=20\text{mA}$.

4.3 Block Diagram

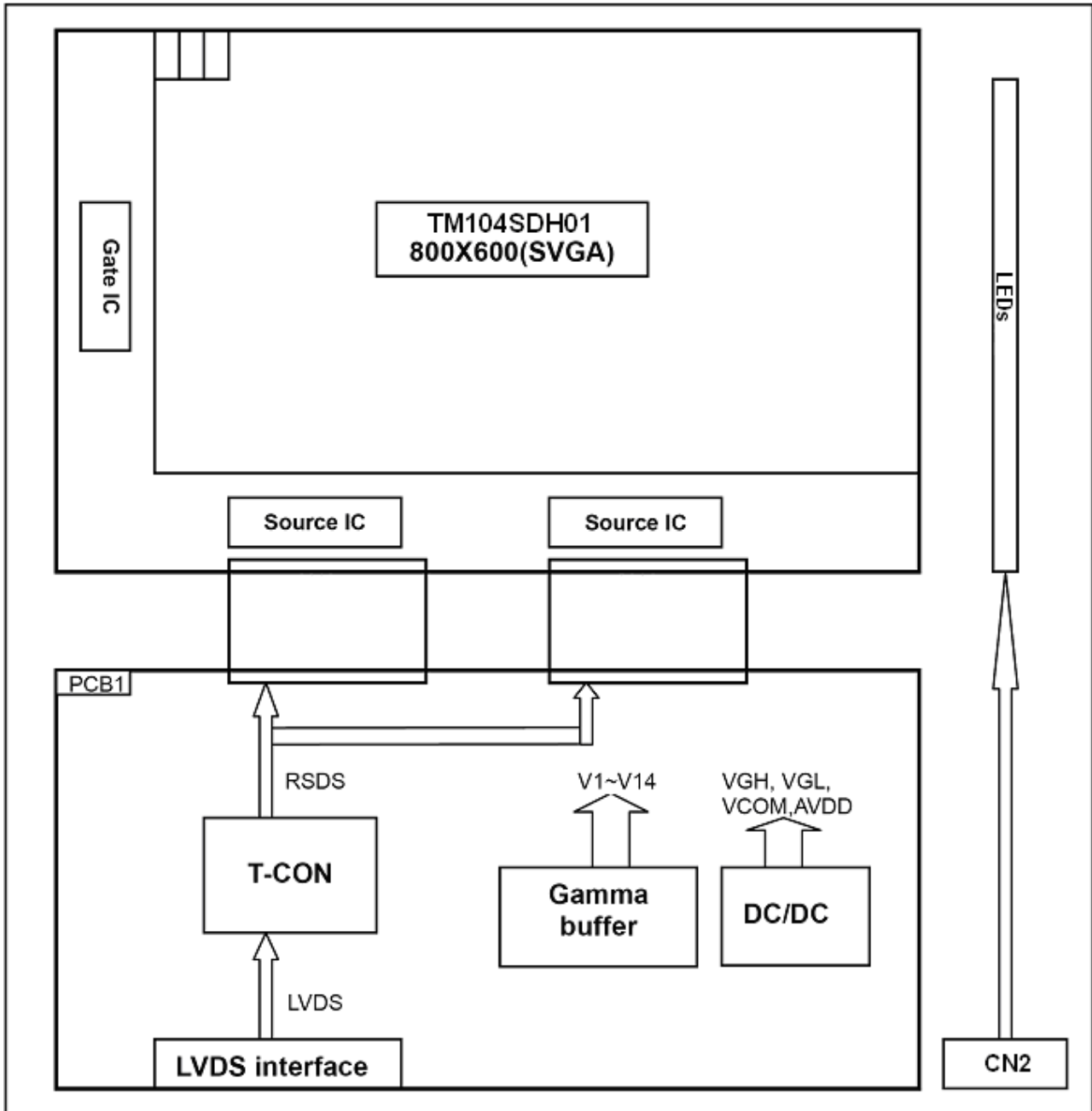

TIANMA

5 Timing Chart

5.1 Timing Parameter

Item	Symbol	Min	Typ	Max	Unit	Condition
Clock period	tLVCP	20.0	25	31.25	ns	
Clock high time	tLVCH	-	14.29	-	ns	
Clock low time	tLVCL	-	10.71	-	ns	
PLL wake-up time	tLVPLL	-	-	1	ms	
Input skew margin	tLVSKM	400	-	-	ps	f=85MHz

Table 5.1 timing parameter

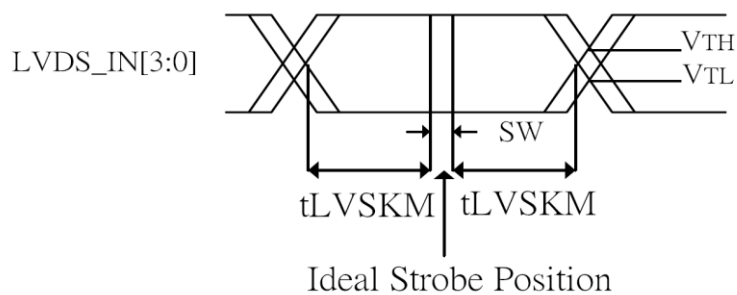
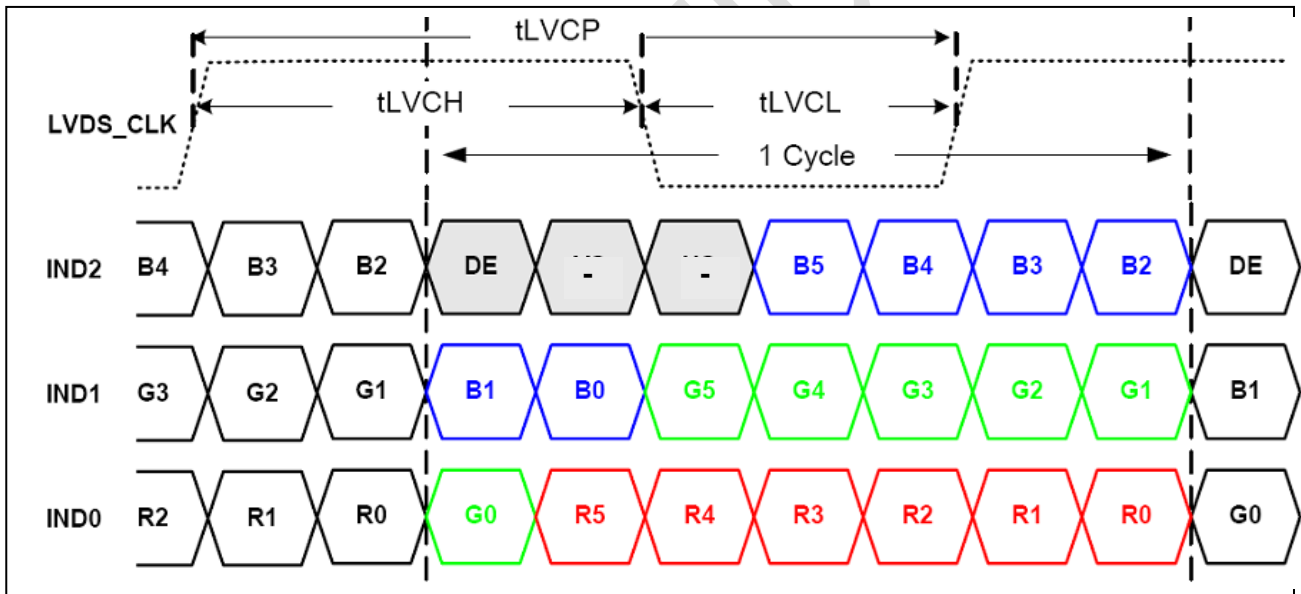
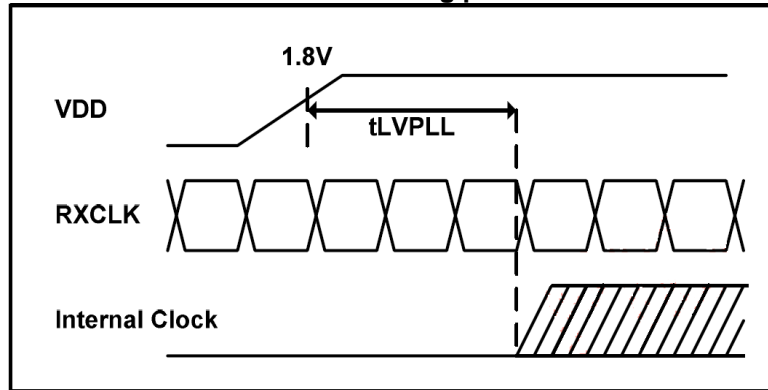

The information contained herein is the exclusive property of TIANMA MICRO-ELECTRONICS Corporation and shall not be distributed, reproduced, or disclosed in whole or in part without prior written permission of TIANMA MICRO-ELECTRONICS Corporation.

SW: Setup and Hold time
 Figure 5.1 Input signal data timing

5.2 Recommended Input Timing of LVDS transmitter

	Parameter	Symbol	Min.	Typ.	Max.	Unit	Remarks
Dclk frequency		1/Tclk	32	40	50	MHz	
Horizontal section	Horizontal total	Th	866	1056	1064	Tclk	
	Horizontal blanking	Thb	66	256	264	Tclk	
	Valid Data Width	Thd	800	800	800	Tclk	
Vertical section	Frame rate	-	-	60	70	Hz	
	Vertical total	Tv	604	628	800	Th	
	Vertical blanking	Tvb	4	28	200	Th	
	Valid Data Width	Tvd	600	600	600	Th	

Note: DE signal is necessary.

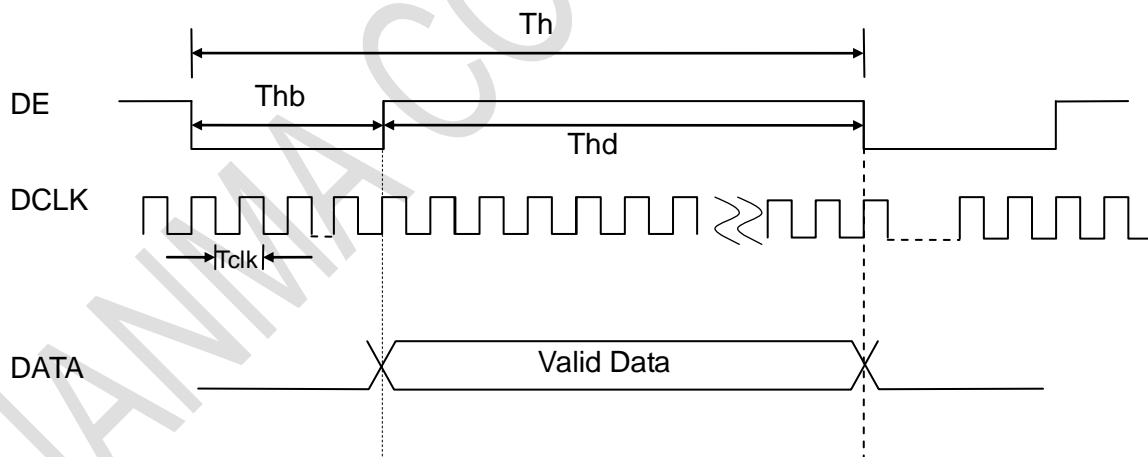
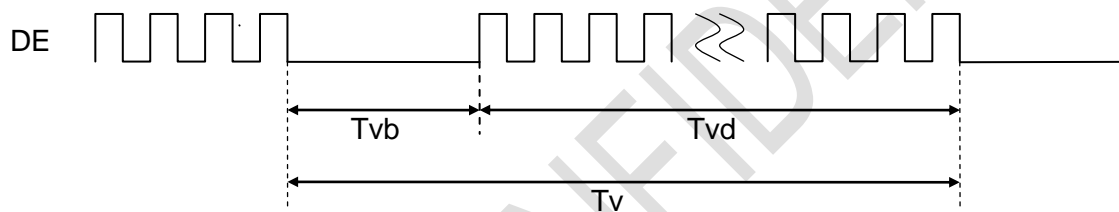
Input Timing Control Conditions

5.3 Power On/Off Sequence

Item	Symbol	Min	Typ	Max	Unit	Remark
VDD 3.0V to signal starting	Tp1	0	-	50	ms	
Signal starting to backlight on	Tp2	150	-	-	ms	
Signal off to VDD 3.0V	Tp3	0	-	50	ms	
Backlight off to signal off	Tp4	150	-	-	ms	

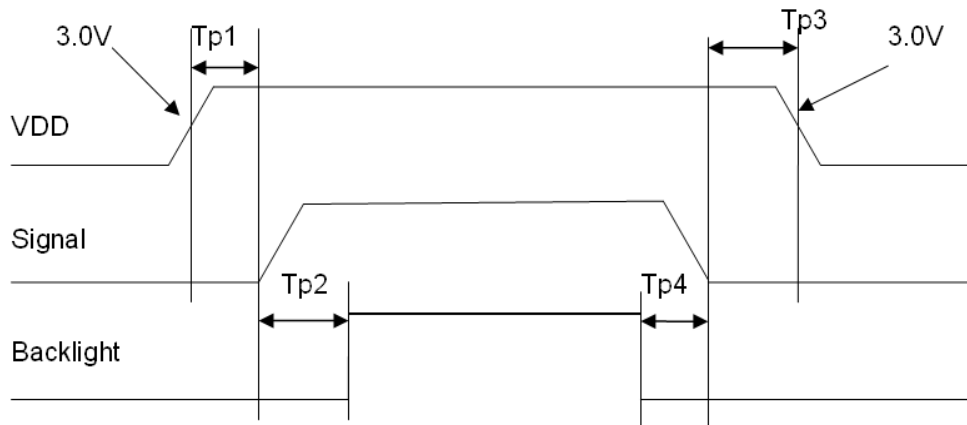
Figure 5.2 Interface power on/off sequence

6 Optical Characteristics

Item	Symbol	Condition	Min	Typ	Max	Unit	Remark
View Angles	θT	$CR \geq 10$	50	60	-	Degree	Note2,3
	θB		60	70	-		
	θL		60	70	-		
	θR		60	70	-		
Contrast Ratio	CR	$\theta=0^\circ$	300	400	-		Note 3
Response Time	T_{ON}	25°C	-	10	15	ms	Note 4
	T_{OFF}		-	15	25		
Chromaticity	White	Backlight is on	x	0.259	0.309	0.359	Note 1,5
			y	0.284	0.334	0.384	
	Red		x	0.550	0.600	0.650	Note 1,5
			y	0.296	0.346	0.396	
	Green		x	0.283	0.333	0.383	Note 1,5
			y	0.516	0.566	0.616	
	Blue		x	0.092	0.142	0.192	Note 1,5
			y	0.065	0.115	0.165	
Uniformity	U		70	80	-	%	Note 6
NTSC			45	50	-	%	Note 5
Luminance	L		350	400	-	cd/m ²	Note 7

Test Conditions:

1. $I_F=120\text{ mA}$, and the ambient temperature is 25°C.
2. The test systems refer to Note 1 and Note 2.

Note 1: Definition of optical measurement system.

The optical characteristics should be measured in dark room. After 5 Minutes operation, the optical properties are measured at the center point of the LCD screen. All input terminals LCD panel must be ground when measuring the center area of the panel.

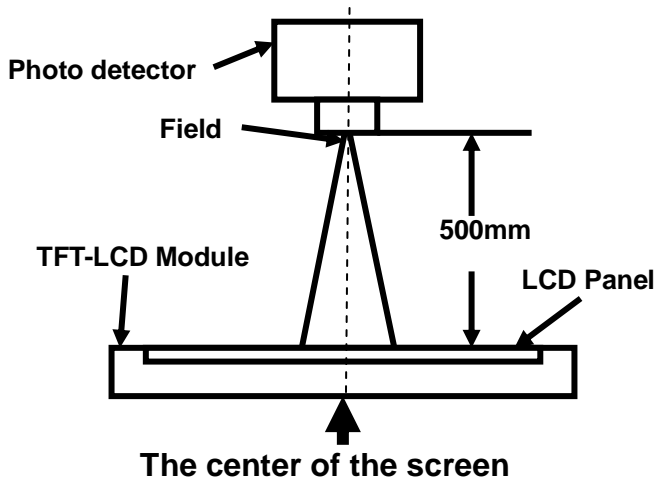

Note 2: Definition of viewing angle range and measurement system.

viewing angle is measured at the center point of the LCD by CONOSCOPE(ergo-80).

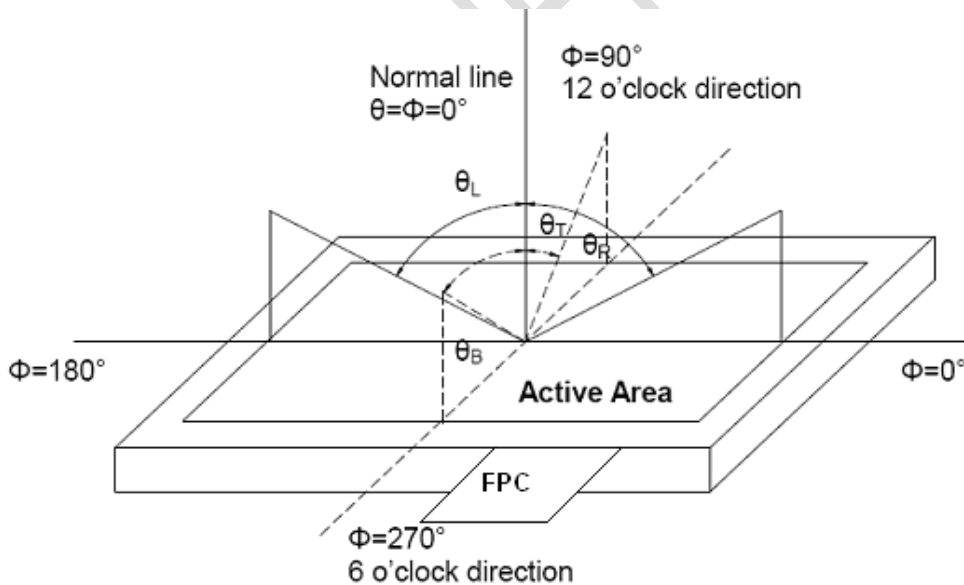

Note 3: Definition of contrast ratio

$$\text{Contrast ratio (CR)} = \frac{\text{Luminance measured when LCD is on the "White" state}}{\text{Luminance measured when LCD is on the "Black" state}}$$

“White state “: The state is that the LCD should drive by V_{white} .

“Black state”: The state is that the LCD should drive by V_{black} .

V_{white} : To be determined V_{black} : To be determined.

The information contained herein is the exclusive property of TIANMA MICRO-ELECTRONICS Corporation and shall not be distributed, reproduced, or disclosed in whole or in part without prior written permission of TIANMA MICRO-ELECTRONICS Corporation.

Note 4: Definition of Response time

The response time is defined as the LCD optical switching time interval between “White” state and “Black” state. Rise time (T_{ON}) is the time between photo detector output intensity changed from 90% to 10%. And fall time (T_{OFF}) is the time between photo detector output intensity changed from 10% to 90%.

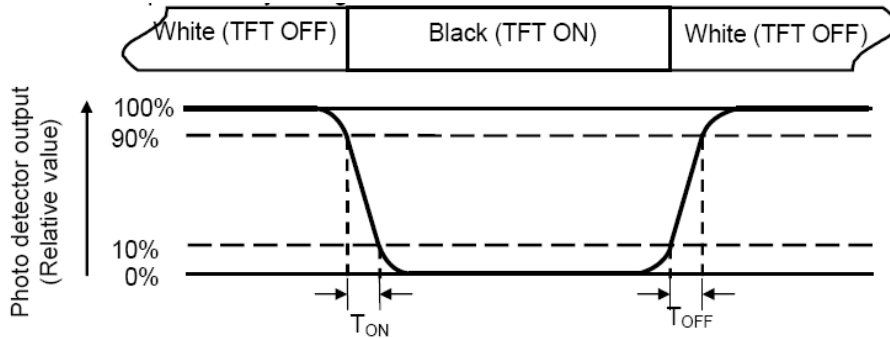

Note 5: Definition of color chromaticity (CIE1931)

Color coordinates measured at center point of LCD.

Note 6: Definition of Luminance Uniformity

Active area is divided into 9 measuring areas (Refer Fig. 2). Every measuring point is placed at the center of each measuring area.

$$\text{Luminance Uniformity (U)} = L_{\min} / L_{\max}$$

L-----Active area length W----- Active area width

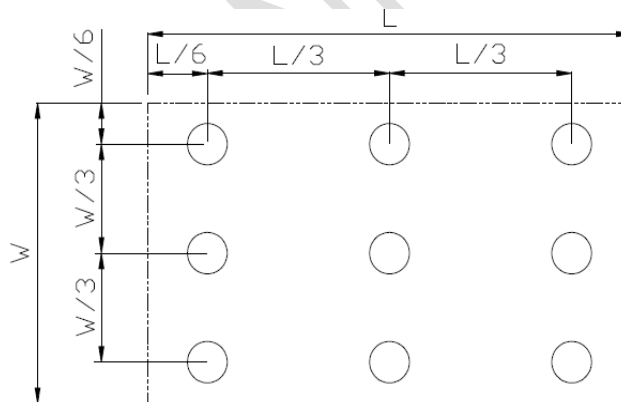

L_{\max} : The measured Maximum luminance of all measurement position.

L_{\min} : The measured Minimum luminance of all measurement position.

Note 7: Definition of Luminance:

Measure the luminance of white state at center point.

7 Environmental / Reliability Test

No	Test Item	Condition	Remarks
1	High Temperature Operation	Ts=+70℃, 240hrs	IEC60068-2-1:2007 GB2423.2-2008
2	Low Temperature Operation	Ta=-20℃, 240hrs	IEC60068-2-1:2007 GB2423.1-2008
3	High Temperature Storage	Ta=+80℃, 240hrs	IEC60068-2-1:2007 GB2423.2-2008
4	Low Temperature Storage	Ta=-30℃, 240hrs	IEC60068-2-1:2007 GB2423.1-2008
5	Storage at High Temperature and Humidity	Ta = +60℃, 90% RH max,240 hours	IEC60068-2-78 :2001 GB/T2423.3—2006
6	Thermal Shock (non-operation)	-20℃ 30 min~+70℃ 30 min, Change time:5min, 100 Cycles	Start with cold temperature, End with high temperature, IEC60068-2-14:1984,G B2423.22-2002
7	ESD	C=150pF,R=330Ω, Air:±15Kv, Contact:±8Kv, 10times/terminal	IEC61000-4-2:2001 GB/T17626.2-2006
8	Vibration Test	Frequency range:10~55Hz, Stroke:1.5mm Sweep:10Hz~55Hz~10Hz 2hours for each direction of X.y.z (6 hours for total)	IEC60068-2-6:1982 GB/T2423.10—1995
9	Mechanical Shock (Non OP)	80G 6ms, ±X,±Y,±Z 3 times for each direction	IEC60068-2-27:1987 GB/T2423.5—1995
10	Package Drop Test	Height:80 cm,1 corner, 3 edges, 6 surfaces	IEC60068-2-32:1990 GB/T2423.8—1995
11	Package Vibration Test	Random Vibration: 0.015GxG/Hz for 5-200Hz, -6dB/Octave from 200-500Hz 2 hours for each direction of X,Y,Z (6 hours for total)	IEC60068-2-34 GB/T2423.11

Note1: Ts is the temperature of panel's surface.

Note2: Ta is the ambient temperature of sample.

Note3: Before cosmetic and function test, the product must have enough recovery time, at least 2 hours at room temperature.

Note 4: In the standard condition, there shall be no practical problem that may affect the display function. After the reliability test, the product only guarantees operation, but don't guarantee all of the cosmetic specification.

8 Mechanical Drawing

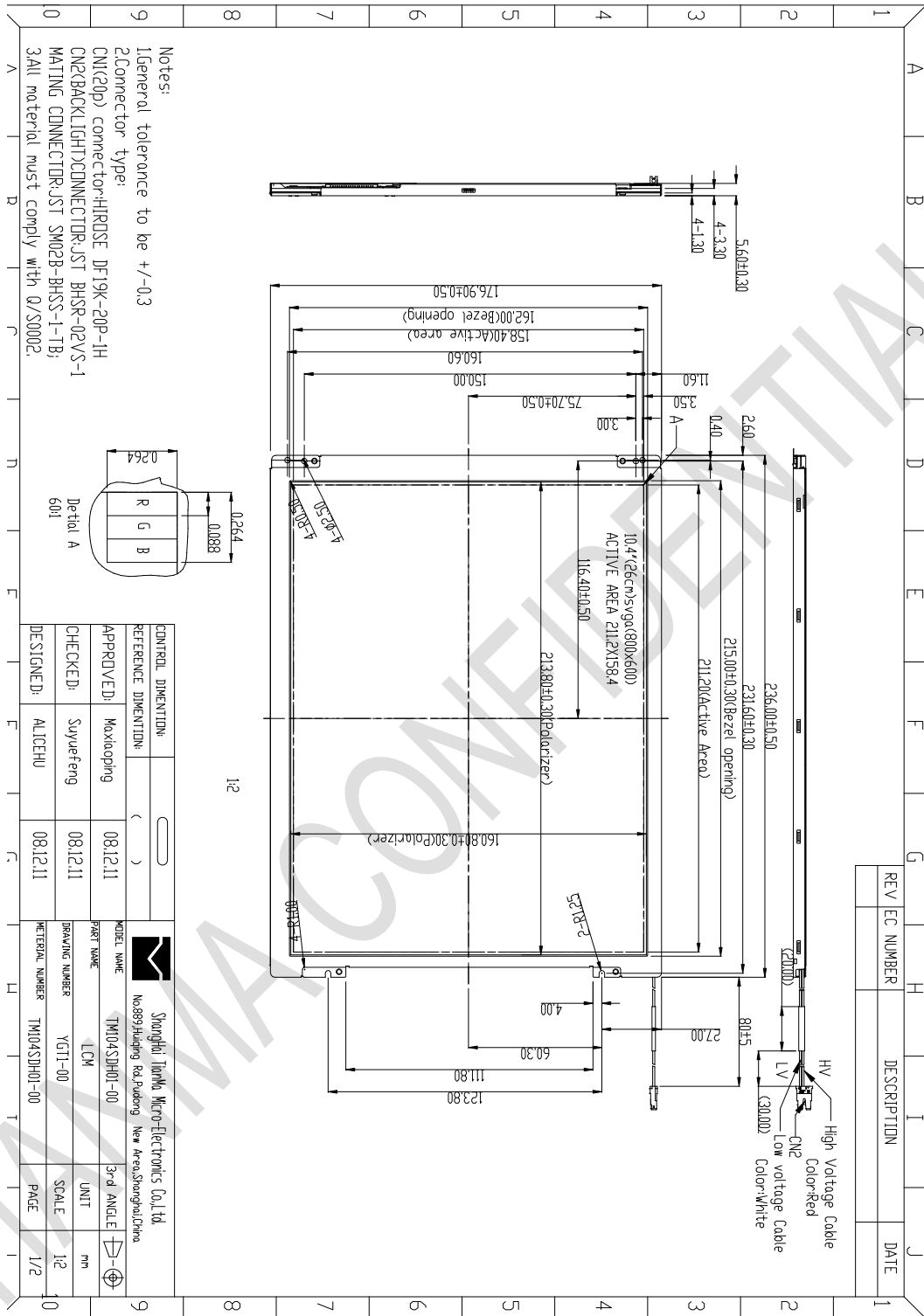

The information contained herein is the exclusive property of TIANMA MICRO-ELECTRONICS Corporation and shall not be distributed, reproduced, or disclosed in whole or in part without prior written permission of TIANMA MICRO-ELECTRONICS Corporation.

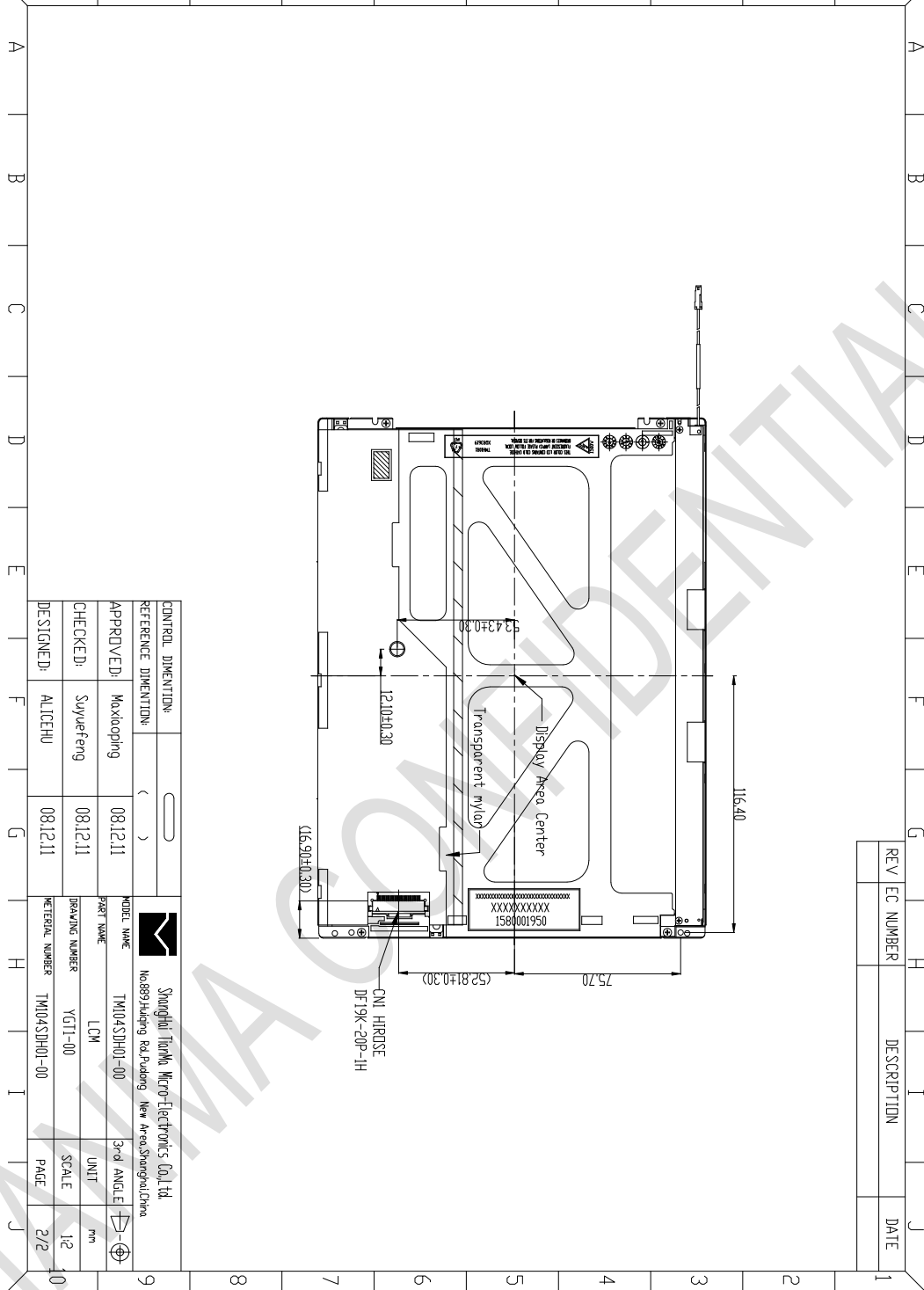

The information contained herein is the exclusive property of TIANMA MICRO-ELECTRONICS Corporation and shall not be distributed, reproduced, or disclosed in whole or in part without prior written permission of TIANMA MICRO-ELECTRONICS Corporation.

9 Packing Drawing

No	Item	Model (Material)	Dimensions(mm)	Unit Weight(Kg)	Quantity	Remark
1	LCM module	TM104SDH01-60	236.00x176.90x5.60	0.29	25	
2	Partition_1	CORRUGATED PAPER	513x333x217	1.476	1	
3	Anti-static Bag	PE	247x256x0.05	0.004	25	
4	DUST-PROOF BAG	PE	700x530	0.05	1	
5	Partition_2	CORRUGATED PAPER	505x332x4.0	0.1	2	
6	CORRUGATED	CORRUGATED PAPER	513x248	0.102	2	
7	Carton	CORRUGATED PAPER	530x350x250	1.02	1	
8	Total weight(Kg)	10.3Kg±10%				

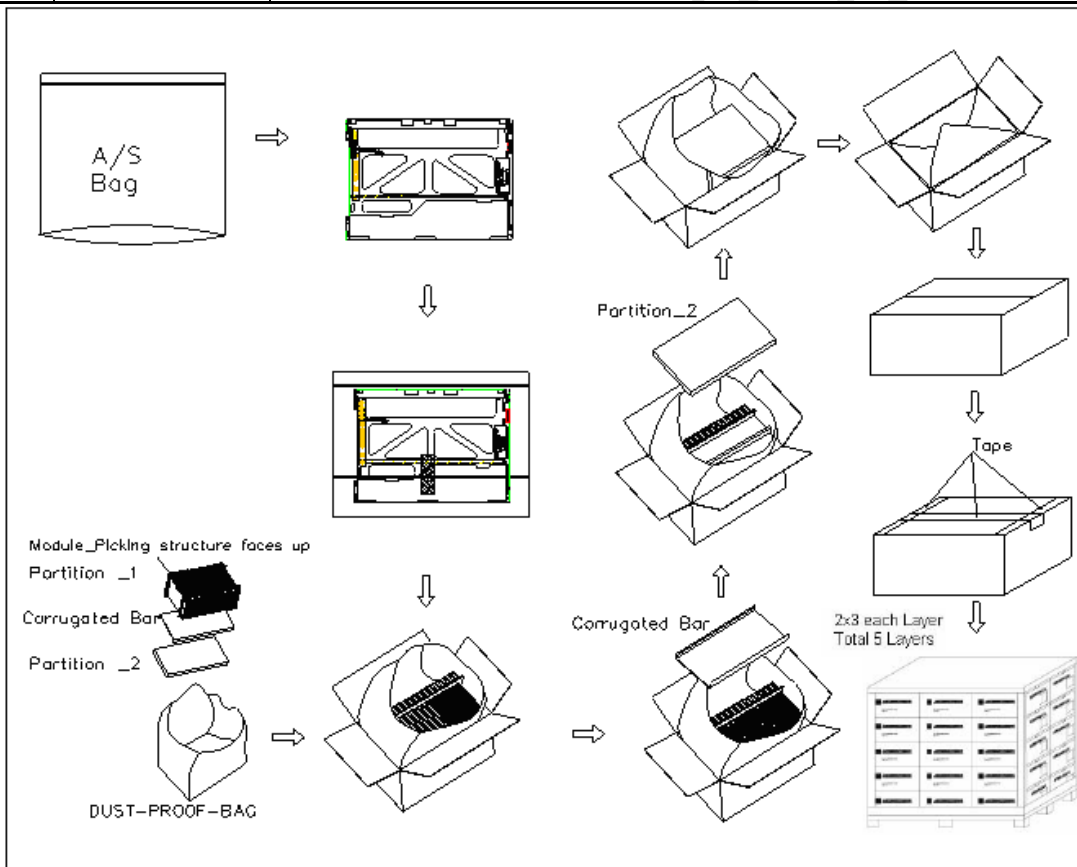

10 Precautions for Use of LCD Modules

10.3 Handling Precautions

10.3.1 The display panel is made of glass. Do not subject it to a mechanical shock by dropping it from a high place, etc.

10.3.2 If the display panel is damaged and the liquid crystal substance inside it leaks out, be sure not to get any in your mouth, if the substance comes into contact with your skin or clothes, promptly wash it off using soap and water.

10.3.3 Do not apply excessive force to the display surface or the adjoining areas since this may cause the color tone to vary.

10.3.4 The polarizer covering the display surface of the LCD module is soft and easily scratched. Handle this polarizer carefully.

10.3.5 If the display surface is contaminated, breathe on the surface and gently wipe it with a soft dry cloth. If still not completely clear, moisten cloth with one of the following solvents:

- Isopropyl alcohol
- Ethyl alcohol

Solvents other than those mentioned above may damage the polarizer. Especially, do not use the following:

- Water
- Ketone
- Aromatic solvents

10.3.6 Do not attempt to disassemble the LCD Module.

10.3.7 If the logic circuit power is off, do not apply the input signals.

10.3.8 To prevent destruction of the elements by static electricity, be careful to maintain an optimum work environment.

10.1.8.1 Be sure to ground the body when handling the LCD Modules.

10.1.8.2 Tools required for assembly, such as soldering irons, must be properly ground.

10.1.8.3 To reduce the amount of static electricity generated, do not conduct assembly and other work under dry conditions.

10.1.8.4 The LCD Module is coated with a film to protect the display surface. Be care when peeling off this protective film since static electricity may be generated.

10.4 Storage precautions

10.4.1 When storing the LCD modules, avoid exposure to direct sunlight or to the light of fluorescent lamps.

10.4.2 The LCD modules should be stored under the storage temperature range. If the LCD modules will be stored for a long time, the recommend condition is:

Temperature : 0°C ~ 40°C Relatively humidity: ≤80%

10.4.3 The LCD modules should be stored in the room without acid, alkali and harmful gas.

10.5 Transportation Precautions

10.5.1 The LCD modules should be no falling and violent shocking during transportation, and also should avoid excessive press, water, damp and sunshine.