

FEATURES

1. Continuous short-circuit protection
2. No-load input current as low as 8mA
3. Operating ambient temperature range: -40°C to +85°C
4. High efficiency up to 71%
5. Compact SMD package
6. I/O isolation test voltage 1.5k VDC
7. Industry standard pin-out



**3 years
Warranty**

Selection Guide

Part No.	Input Voltage (VDC)	Output		Full Load Efficiency (%) Min./Typ.	Capacitive Load (µF) Max.
	Nominal (Range)	Voltage (VDC)	Current (mA) Max./Min.		
IB0503XT-1WR3	5 (4.75-5.25)	3.3	250/25	62/66	2400
IB0505XT-1WR3		5	200/20	65/69	2400
IB0509XT-1WR3		9	111/12	66/70	1000
IB0512XT-1WR3		12	84/9	67/71	560
IB0515XT-1WR3		15	67/7	67/71	560
IB1205XT-1WR3	12 (11.4-12.6)	5	200/20	65/69	2400
IB1212XT-1WR3		12	84/9	67/71	560
IB1215XT-1WR3		15	67/7	67/71	220
IB1505XT-1WR3	15 (14.25-15.75)	5	200/20	64/68	2400
IB2405XT-1WR3	24 (22.8-25.2)	5	200/20	63/69	2400
IB2412XT-1WR3		12	84/9	65/71	560
IB2415XT-1WR3		15	67/7	65/71	220

Input Specifications

Item	Operating Conditions	Min.	Typ.	Max.	Unit	
Input Current (full load / no-load)	5VDC input	3.3VDC output	-	303/8	323/--	mA
		5VDC output	-	290/8	308/--	
		9VDC output	-	286/8	304/--	
		12VDC/15VDC output	-	282/9	299/--	
	12VDC input	5VDC output	-	121/8	128/--	
		12VDC/15VDC output	-	117/8	124/--	
	15VDC input		-	99/8	105/--	
	24VDC input	5VDC output	-	60/4	66/--	
12VDC/15VDC output		-	59/4	64/--		
Reflected Ripple Current*		-	30	-		
Input Filter		Capacitance Filter				
Hot Plug		Unavailable				

Note: * Refer to DC-DC Converter Application Notes for detailed description of reflected ripple current test method.

Output Specifications

Item	Operating Conditions	Min.	Typ.	Max.	Unit
Voltage Accuracy	100% load	-	-	±3	%
Linear Regulation	Input voltage change: ±1%	-	-	±0.25	
Load Regulation	10%-100% load	3.3VDC output		±3	
		All other output voltages		±2	
Ripple & Noise*	20MHz bandwidth	-	30	100	mVp-p
Temperature Coefficient	100% load	5VDC input		±0.03	% / °C
		12/15/24VDC input		±0.02	
Short-circuit Protection		Continuous, self-recovery			

Note: * The "parallel cable" method is used for Ripple and Noise test, please refer to DC-DC Converter Application Notes for specific information.

General Specifications

Item	Operating Conditions	Min.	Typ.	Max.	Unit
Isolation	Input-output electric strength test for 1 minute with a leakage current of 1mA max.	1500	-	-	VDC
Insulation Resistance	Input-output resistance at 500VDC	1000	-	-	MΩ
Isolation Capacitance	Input-output capacitance at 100kHz/0.1V	-	20	-	pF
Operating Temperature	Derating when operating temperature ≥ 71°C (see Fig.1)	-40	-	85	°C
Storage Temperature		-55	-	125	
Case Temperature Rise	Ta=25°C	3.3VDC output		30	
		All other output voltages		25	
Pin Soldering Resistance Temperature	Soldering spot is 1.5mm away from case for 10 seconds	-	-	300	
Storage Humidity	Non-condensing	5VDC input		95	%RH
		12/15/24VDC input		5	
Vibration		10-150Hz, 5G, 30 Min. along X, Y and Z			
Reflow Soldering Temperature*		Peak temp. ≤245°C, maximum duration time ≤60s over 217°C			
Switching Frequency	100% load, nominal input voltage	5VDC input		250	kHz
		12/15/24VDC input		260	
MTBF	MIL-HDBK-217F@25°C	3500	-	-	k hours
Moisture Sensitivity Level (MSL)	IPC/JEDEC J-STD-020D.1	Level 1			

Note: *Please refer to IPC/JEDEC J-STD-020D.1.

Mechanical Specifications

Case Material	Black plastic; flame-retardant and heat-resistant (UL94V-0)
Dimensions	15.24 x 11.40 x 7.25 mm
Weight	1.2g(Typ.)
Cooling Method	Free air convection

Electromagnetic Compatibility (EMC)

Emissions	CE	CISPR32/EN55032 CLASS B
	RE	CISPR32/EN55032 CLASS B
Immunity	ESD	IEC/EN61000-4-2 Air ±8kV, Contact ±6kV perf. Criteria B

Note: Refer to Fig.3 for recommended circuit test.

Typical Characteristic Curves

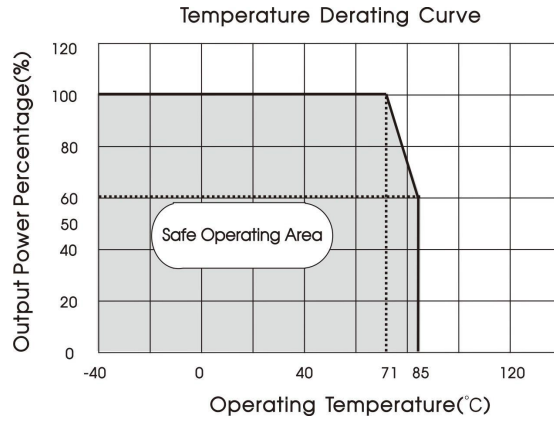
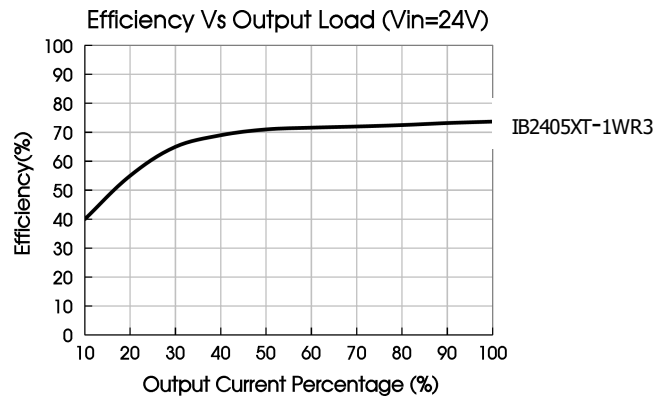
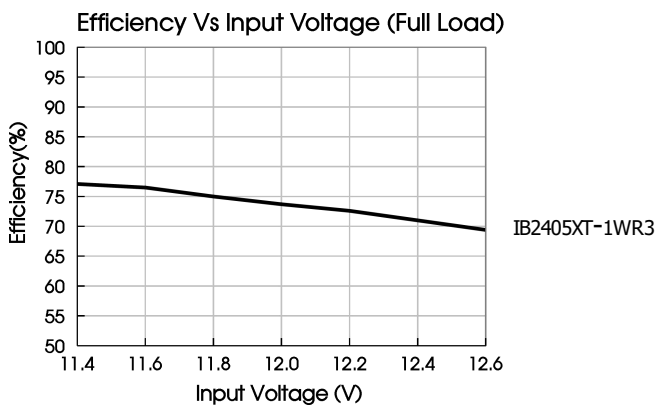
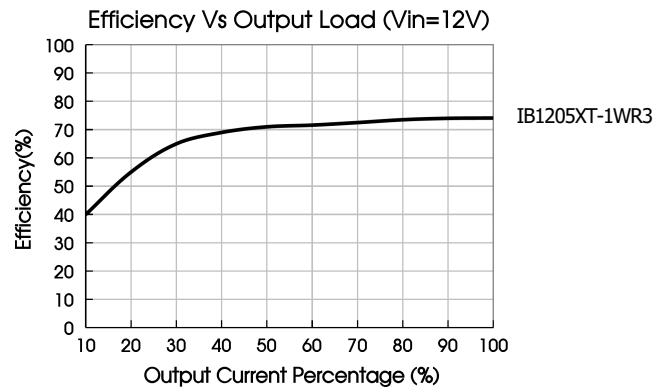
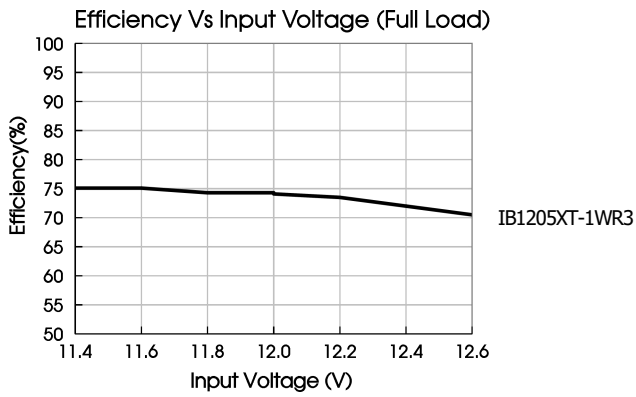
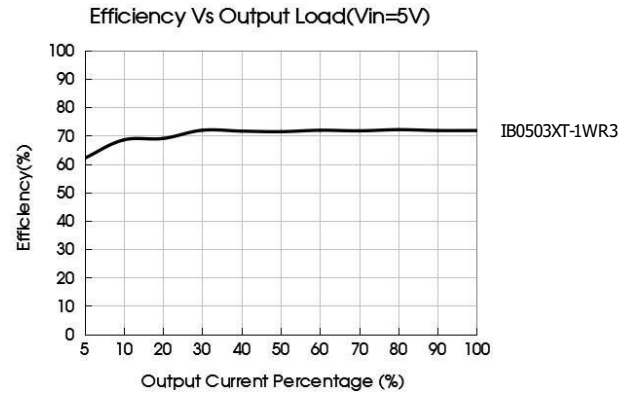
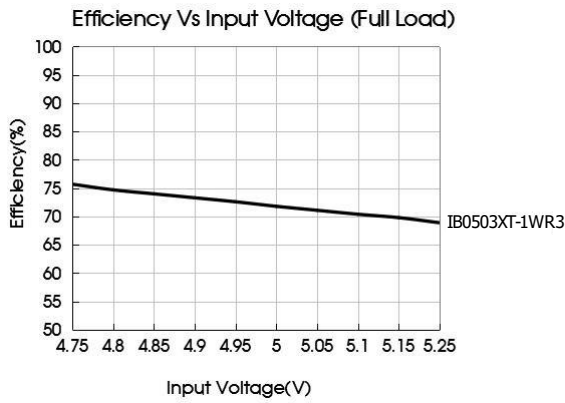

Fig. 1



Design Reference

1. Typical application circuit

Input and/or output ripple can be further reduced, by connecting a filter capacitor from the input and/or output terminals to ground as shown in Fig. 2. Choosing suitable filter capacitor values is very important for a smooth operation of the modules, particularly to avoid start-up problems caused by capacitor values that are too high. For recommended input and output capacitor values refer to Table 1.

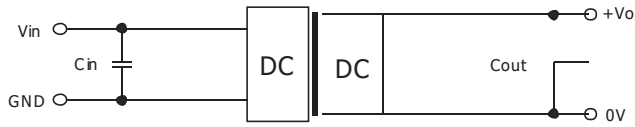

Fig. 2

Table 1: Recommended input and output capacitor values

Vin	Cin	Vo	Cout
5VDC	4.7µF/16V	3.3/5VDC	10µF/16V
		9/12VDC	2.2µF/25V
		15VDC	1µF/25V
12VDC	2.2µF/16V	5VDC	10µF/16V
		12VDC	2.2µF/25V
		15VDC	0.47µF/50V
15VDC	1µF/25V	5VDC	10µF/16V
24VDC	1µF/50V	5VDC	10µF/16V
		12VDC	2.2µF/25V
		15VDC	0.47µF/50V

2. EMC compliance circuit

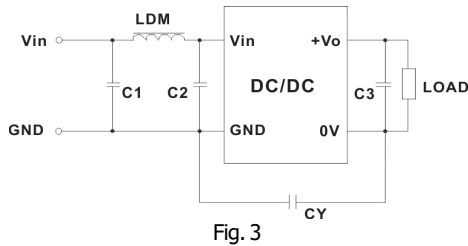

Fig. 3

Table 2: Recommended EMC filter values

input voltage	5VDC		12/15/24VDC
Output voltage	3.3/5/9VDC	12/15VDC	5/12/15VDC
Emissions	C1/C2	4.7µF /25V	4.7µF /25V
	CY	47pF/2kVDC	1nF/2kVDC
	C3	Refer to the Cout in table 1	
	LDM	6.8µH	

Note: To further improve EMI performance, we recommend the use a Y-capacitor CY

Dimensions and Recommended Layout

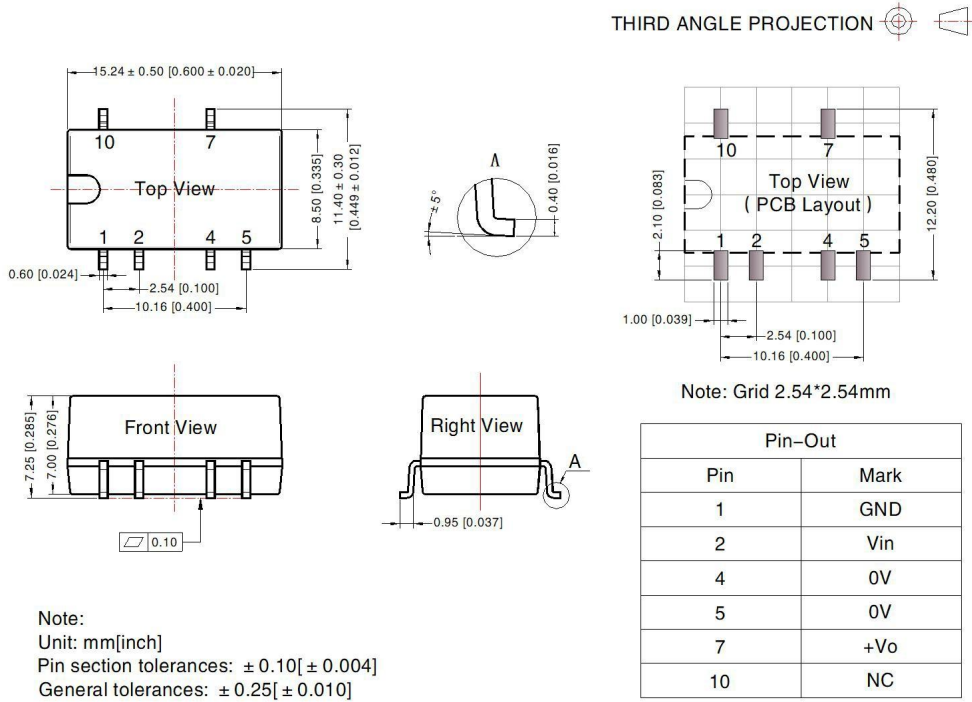

NC: Pin to be isolated from circuitry

Tape and Reel Info

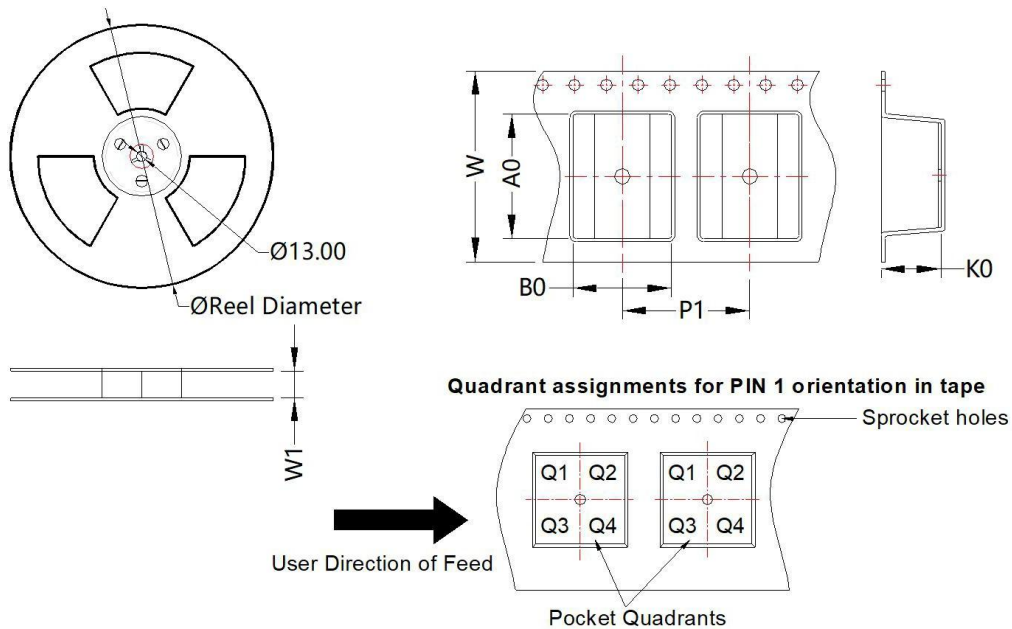

Device	Package Type	Pin	SPQ	Reel Diameter (mm)	Reel Width W1 (mm)	A0 (mm)	B0 (mm)	K0 (mm)	P1 (mm)	W (mm)	Pin1 Quadrant
IB_XT-1WR3	SMD	6	500	330.0	24.5	15.64	12.4	7.45	16.0	24.0	Q1

Notes & Instructions

1. If the product works under the minimum required load, it cannot guarantee that the performance of the product complies with all the performance indicators in this manual;
2. The maximum capacitive load is tested under the input voltage range and full load condition;
3. Unless otherwise stated, all indexes in this manual are measured at $T_a=25^{\circ}\text{C}$, humidity $<75\%RH$, nominal input voltage and rated output load;
4. All index testing methods in this manual are based on the enterprise standards of the company;
5. Our company can provide product customization, specific needs can directly contact our technical staff;