



Product Specification

G270QAN01.0

AU OPTRONICS CORPORATION

(v) Preliminary Specifications

() Final Specifications

Module	27 Inch Color TFT-LCD
Model Name	G270QAN01.0

Customer	Date
_____	_____
Checked & Approved by	Date
_____	_____
Customer's sign back page	

Approved by	Date
<u>Jerry Chen</u>	<u>Jan. 25, 2019</u>
Prepared by	Date
<u>Audrey HC Lin</u>	<u>Jan. 25, 2019</u>
General Display Business Division / AU Optronics corporation	



Contents

1. Operating Precautions 4

2. General Description..... 5

 2.1 Display Characteristics 5

 2.2 Optical Characteristics 6

3. Functional Block Diagram 9

4. Absolute Maximum Ratings 10

 4.1 Absolute Ratings of TFT LCD Module 10

 4.2 Absolute Ratings of Environment 10

5. Electrical Characteristics 11

 5.1 TFT LCD Module 11

 5.2 Backlight Unit 13

6. Signal Characteristic 16

 6.1 Pixel Format Image 16

 6.2 LVDS Data Format 17

 6.3 Signal Description 18

 6.4 Interface Timing 22

 6.5 Power ON/OFF Sequence 24

7. Reliability Test Criteria 25

8. Mechanical Characteristics 26

 8.1 LCM Outline Dimension 26

9. Label and Packaging 28

 9.1 Shipping Label (on the rear side of TFT-LCD display) 28

 9.2 Carton Package 28

10 Safety 29

 10.1 Sharp Edge Requirements 29

 10.2 Materials 29

 10.3 Capacitors 29

 10.4 National Test Lab Requirement 29



Record of Revision

Version	Date (yyyy.mm.dd)	Page	Old description	New Description
00	2018.07.02	-	First edition	
01	2018.10.30	22 24	(P22) Note number 3-3, 3-4 (P24) Modify Power ON/OFF Sequence & Timing & renumber note	(P22) Renumber note as 6-1, 6-2 (P24) Modify Power ON/OFF Sequence & Timing & renumber note as 6-3, 6-4, 6-5
02	2018.12.03	5 6	1. Typo in General Description G270HAN01.0 2. Without RGB color	1. Update model name as G270QAN01.0 2. Add RGB color
03	2018.12.17	6 28	1. Estimated RGB color 2. Pallet size : 1070 mm * 740 mm * 138mm	1. Release RGB Spec. 2. Correct Pallet size : 1060 mm * 760 mm * 132mm
04	2018.12.25	6 15	1. Typo of Rx's minimum value: 0.635 2. LED Forward Current Typ. 120mA	1. Correct Rx's minimum value: 0.655 2. LED Forward Current Typ. 108mA and Max. 120mA,

1. Operating Precautions

- 1) Since front polarizer is easily damaged, please be cautious and not to scratch it.
- 2) Be sure to turn off power supply when inserting or disconnecting from input connector.
- 3) Wipe off water drop immediately. Long contact with water may cause discoloration or spots.
- 4) When the panel surface is soiled, wipe it with absorbent cotton or soft cloth.
- 5) Since the panel is made of glass, it may be broken or cracked if dropped or bumped on hard surface.
- 6) To avoid ESD (Electro Static Discharge) damage, be sure to ground yourself before handling TFT-LCD Module.
- 7) Do not open nor modify the module assembly.
- 8) Do not press the reflector sheet at the back of the module to any direction.
- 9) In case if a module has to be put back into the packing container slot after it was taken out from the container, do not press the center of the LED light bar edge. Instead, press at the far ends of the LED light bar edge softly. Otherwise the TFT Module may be damaged.
- 10) At the insertion or removal of the Signal Interface Connector, be sure not to rotate nor tilt the Interface Connector of the TFT Module.
- 11) TFT-LCD Module is not allowed to be twisted & bent even force is added on module in a very short time. Please design your display product well to avoid external force applying to module by end-user directly.
- 12) Small amount of materials having no flammability grade is used in the LCD module. The LCD module should be supplied by power complied with requirements of Limited Power Source (IEC60950 or UL1950), or be applied exemption.
- 13) Severe temperature condition may result in different luminance, response time and lamp ignition voltage.
- 14) Continuous operating TFT-LCD display under low temperature environment may accelerate lamp exhaustion and reduce luminance dramatically.
- 15) The data on this specification sheet is applicable when LCD module is placed in landscape position.
- 16) Continuous displaying fixed pattern may induce image sticking. It's recommended to use screen saver or shuffle content periodically if fixed pattern is displayed on the screen.



2. General Description

G270QAN01.0 is a Color Active Matrix Liquid Crystal Display composed of a TFT-LCD panel, a driver circuit, and a backlight system. The screen format is intended to support the QHD (2560(H) x 1440(V)) screen and 16.7M colors. All input signals are 4-channel LVDS interface compatible.

2.1 Display Characteristics

The following items are characteristics summary on the table under 25 °C condition:

Items	Unit	Specifications
Screen Diagonal	[inch]	27"
Active Area	[mm]	596.74 (H) × 335.66 (V)
Resolution		2560 X 1440
Pixel Pitch	[mm]	0.2331 (triad) x 0.2331
Pixel Arrangement		R.G.B. Vertical Stripe
Display Mode		AHVA
Nominal Input Voltage VDD	[Volt]	5
Power Consumption	[Watt]	Total = 31.5 W (Typ) LCD = 5.5W, LED = 26 W
Weight	[Grams]	3150 (Typ)
Physical Size	[mm]	630.0 x 368.2 x 15.05 (D) mm (Typ.)
Electrical Interface		4 channel LVDS
Surface Treatment		Anti-Glare
Support Color		16.7 M Colors ,True 8 Bit (RGB)
Temperature Range Operating Storage (Non-Operating)	[°C] [°C]	0 to +50 -20 to +60
RoHS Compliance		RoHS Compliance

2.2 Optical Characteristics

The optical characteristics are measured under stable conditions at 25 °C (Room Temperature):

Item	Unit	Conditions	Min.	Typ.	Max.	Note	
White Luminance	cd/m ²	ILED=120mA(center point)	280	350	-	1	
Uniformity	%	9 points	75	80	-	2,3	
Contrast Ratio	--		700	1000	-	4	
Response Time	msec	Rising	-	8	18	5	
		Falling	-	8	18		
		Rising + Falling	-	16	36		
Viewing Angle	degree	Horizontal CR >= 10	(Right)	75	89	-	6
			(Left)	75	89	-	
		Vertical CR >= 10	(Upper)	70	89	-	
			(Lower)	70	89	-	
Color / Chromaticity Coordinates (CIE 1931)	--	Red x	0.655	0.685	0.715		
		Red y	0.280	0.310	0.340		
		Green x	0.180	0.210	0.240		
		Green y	0.677	0.707	0.737		
		Blue x	0.120	0.150	0.180		
		Blue y	0.020	0.050	0.080		
		White x	0.283	0.313	0.343		
		White y	0.299	0.329	0.359		
Color Gamut	%	Adobe		99			

Note 1: Measurement method

Equipment Pattern Generator, Power Supply, Digital Voltmeter, Luminance meter (SR_3 or equivalent)

Aperture 1° with 50cm viewing distance

Test Point Center

Environment < 1 lux

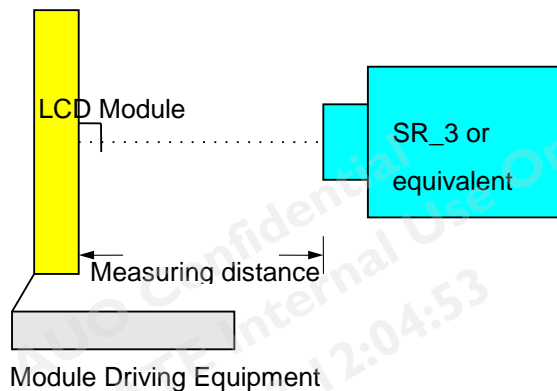

Note 2: Definition of 9 points position

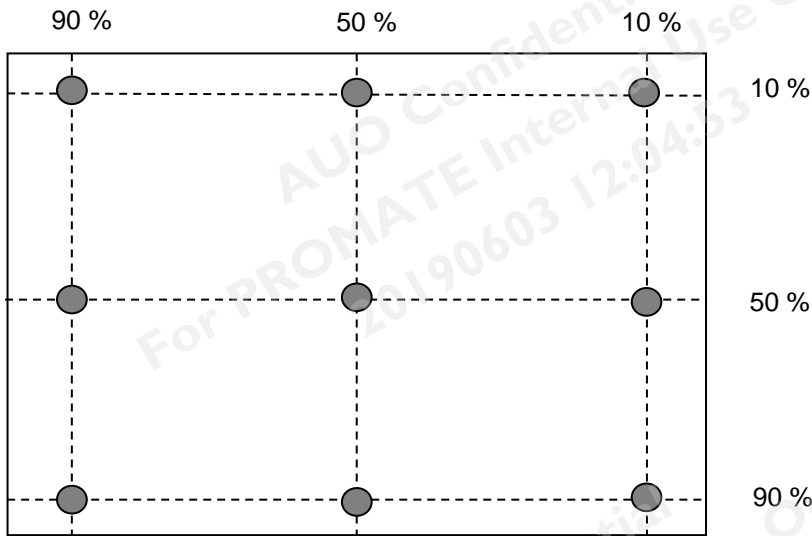

Note 3: The luminance uniformity of 9 points is defined by dividing the minimum luminance values by the maximum test point luminance

$$\delta_{w9} = \frac{\text{Minimum Brightness of nine points}}{\text{Maximum Brightness of nine points}}$$

Note 4: Definition of contrast ratio (CR):

$$\text{Contrast ratio (CR)} = \frac{\text{Brightness on the "White" state}}{\text{Brightness on the "Black" state}}$$

Note 5: Definition of response time:

The output signals of photo detector are measured when the input signals are changed from "White" to "Black" (falling time) and from "Black" to "White" (rising time), respectively. The response time interval is between 10% and 90% of amplitudes. Please refer to the figure as below.

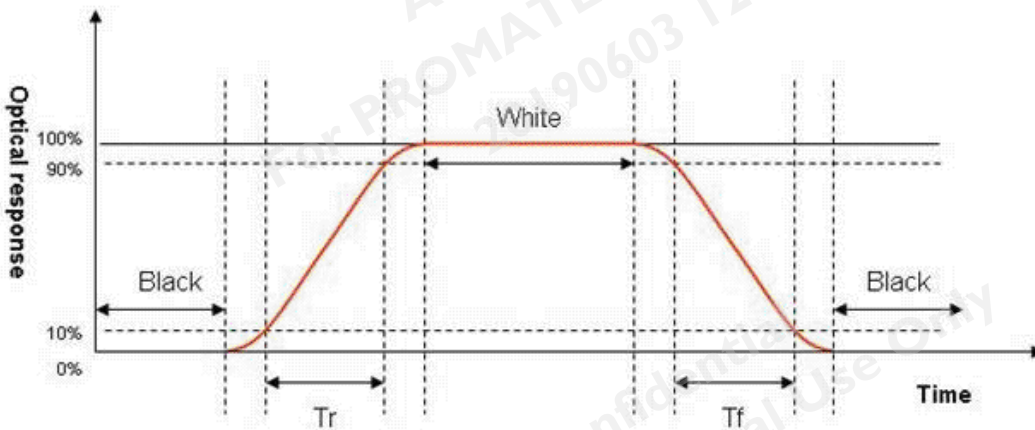

Note 6: Definition of viewing angle

Viewing angle is the measurement of contrast ratio ≥ 10 , at the screen center, over a 180° horizontal and 180° vertical range (off-normal viewing angles). The 180° viewing angle range is broken down as below: 90° (θ) horizontal left and right, and 90° (Φ) vertical high (up) and low (down). The measurement direction is typically perpendicular to the display surface with the screen rotated to its center to develop the desired measurement viewing angle.

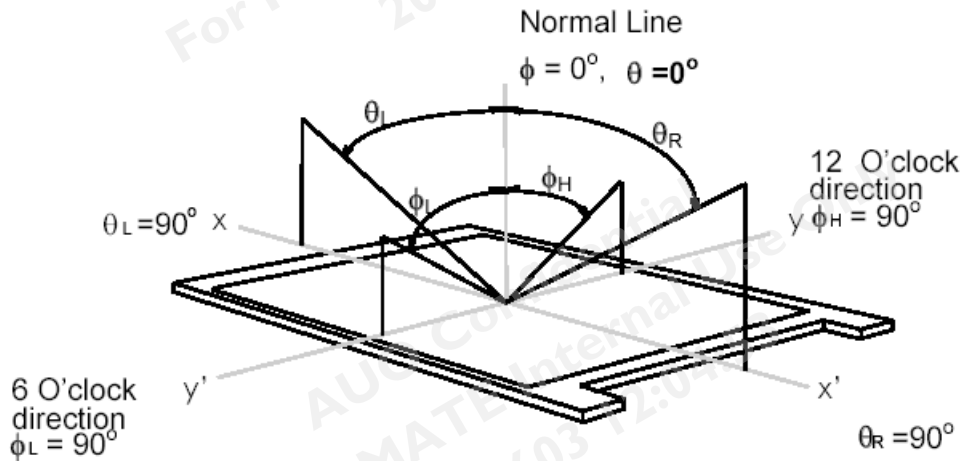

AUO Confidential
 For PROMATE Internal Use Only
 20190603 12:04:53

3. Functional Block Diagram

The following diagram shows the functional block of the 27 inch color TFT/LCD module:

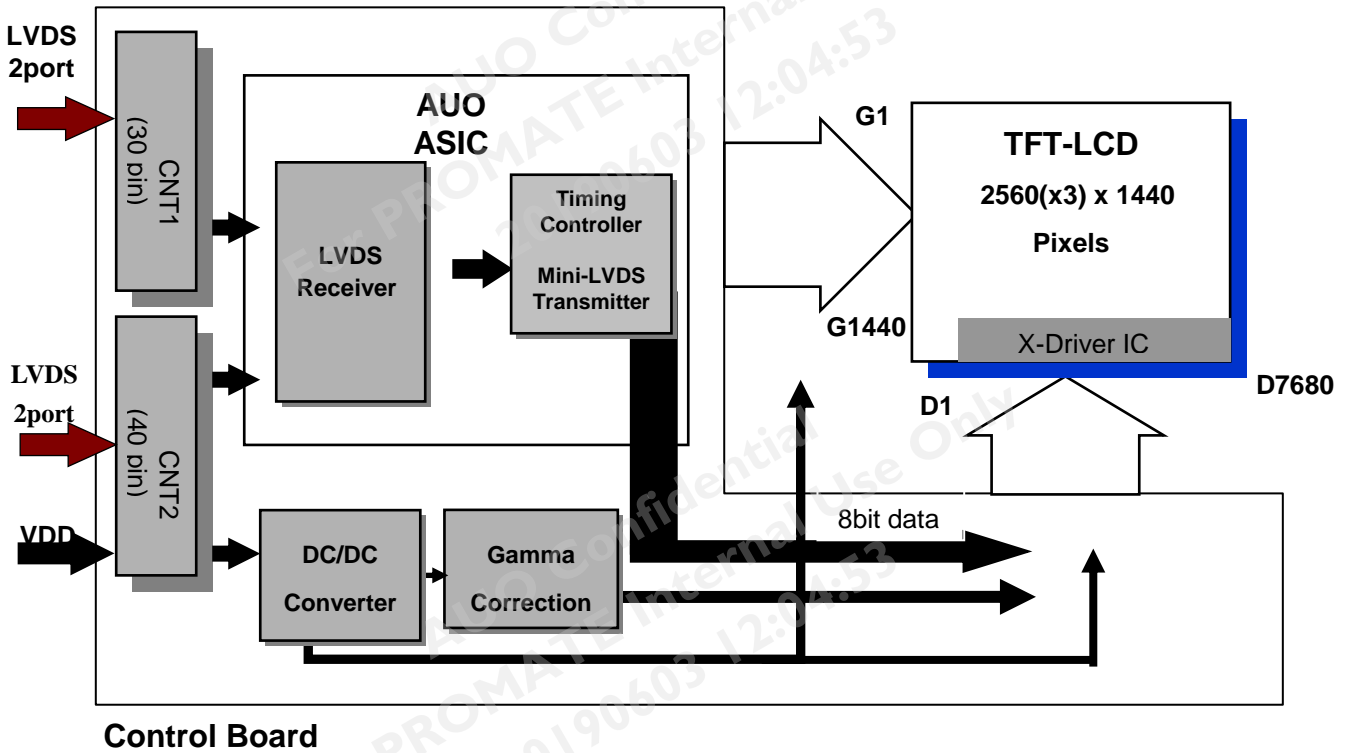

AUO Confidential
 For PROMATE Internal Use Only
 20190603 12:04:53

4. Absolute Maximum Ratings

4.1 Absolute Ratings of TFT LCD Module

Item	Symbol	Min.	Max.	Unit	Conditions
Logic/LCD Drive Voltage	VDD	-0.3	+7	[Volt]	Note 1, 2

4.2 Absolute Ratings of Environment

Item	Symbol	Min.	Max.	Unit	Conditions
Operating	TOP	0	+50	[°C]	Note
Operation Humidity	HOP	5	90	[%RH]	
Storage	TST	-20	+60	[°C]	
Storage Humidity	HST	5	90	[%RH]	

Note 1: With in Ta= 25°C

Note 2: Permanent damage to the device may occur if exceed maximum values

Note 3: For quality performance, please refer to AUO IIS (Incoming Inspection Standard).

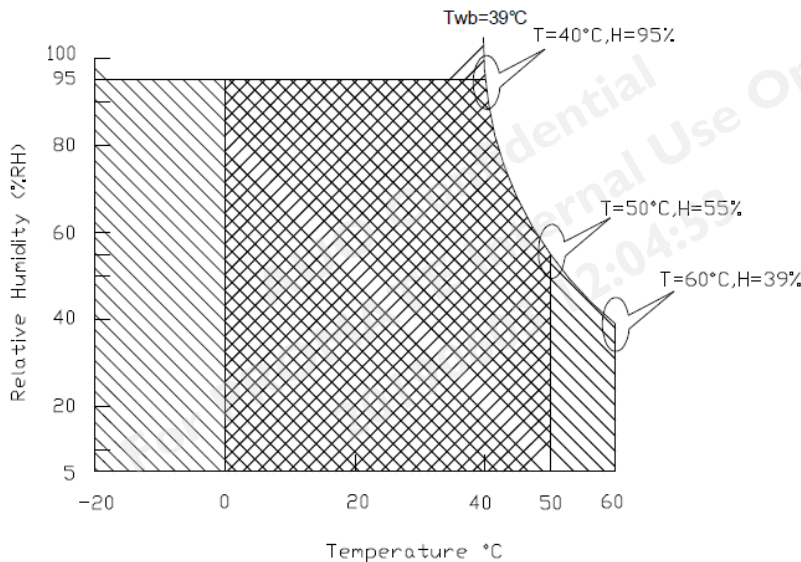

Operating Range

Storage Range +

5. Electrical Characteristics

5.1 TFT LCD Module

5.1.1 Power Specification

Input power specifications are shown as follows:

Symbol	Parameter	Min	Typ	Max	Units	Remark
VDD	Logic/LCD Drive Voltage	4.5	5	5.5	[Volt]	±10%
IDD	VDD Current	-	1.1	1.32	[A]	Vin=5V, White Pattern, at 60Hz
Irush	LCD Inrush Current	-	-	5	[A]	Note 1
PDD	VDD Power	-	5.5	6.6	[Watt]	Vin=5V, White Pattern, at 60Hz
VDDrp	Allowable Logic/LCD Drive Ripple Voltage	-	-	500	[mV] p-p	With panel loading

Note 1: Measurement condition:

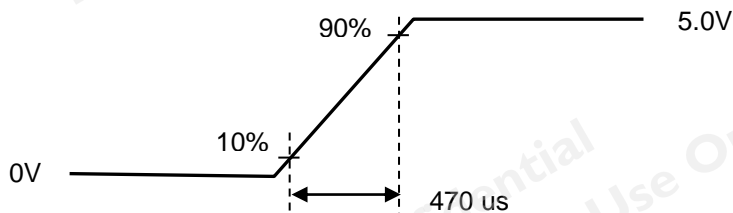
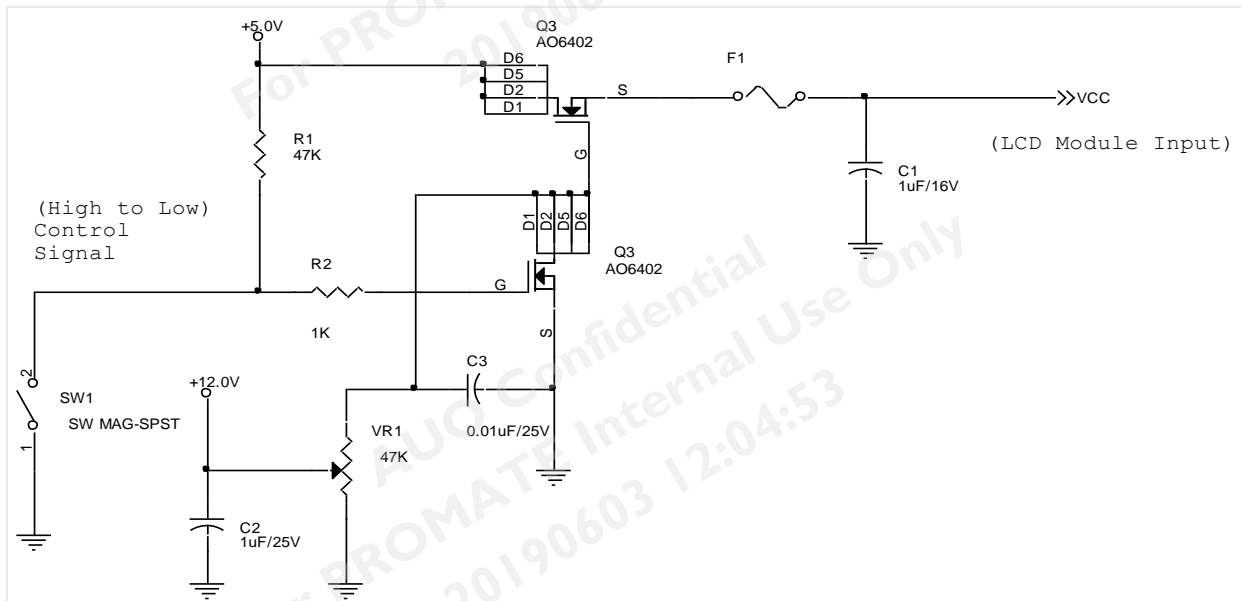

VDD rising time

5.1.2 LVDS DC Signal Electrical Characteristics

Input signals shall be low or Hi-Z state when VDD is off.

Symbol	Item	Min.	Typ.	Max.	Unit	Remark
VTH	Differential Input High Threshold	-	-	+100	[mV]	VCM=1.2V
VTL	Differential Input Low Threshold	-100	-	-	[mV]	VCM=1.2V
VID	Input Differential Voltage	100	-	600	[mV]	
VICM	Differential Input Common Mode Voltage	+1.0	+1.2	+1.5	[V]	VTH/VTL=+-200mV

Note: LVDS Signal Waveform.

Single-end Signal

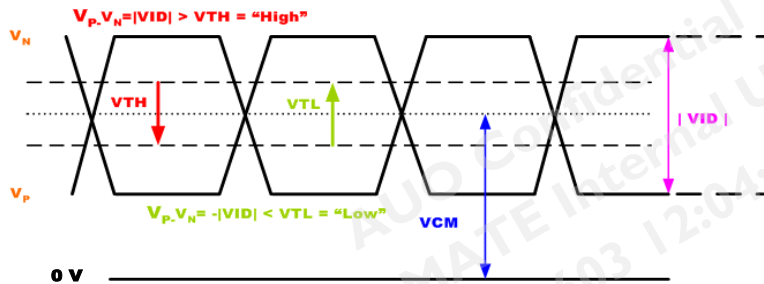

Differential Signal

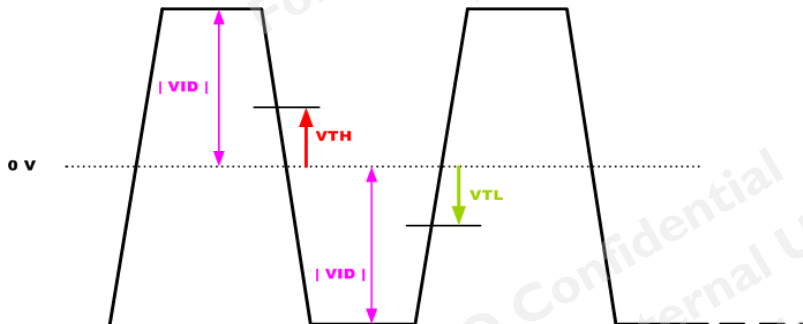

5.2 Backlight Unit

5.2.1 LED Backlight Unit

Backlight Connector	Manufacturer	ENTERY
	Part Number	3707K-S06N-21R
Mating Connector	Manufacturer	ENTERY
	Part Number	H112K-P06N-00B (Non-Locking type) H112K-P06N-03B (Locking type)

5.2.2 Pin Assignment

Pin no.	Signal name
1	Current Feedback
2	Current Feedback
3	VLED (voltage in)
4	VLED (voltage in)
5	Current Feedback
6	Current Feedback

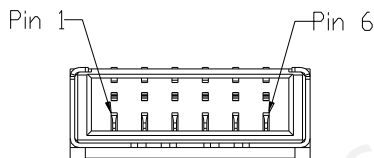

The following shows the block diagram of 27 inch Backlight Unit. And it includes 72 LED in the LED light bar.

(4 strings and 18 pcs LED of one string)

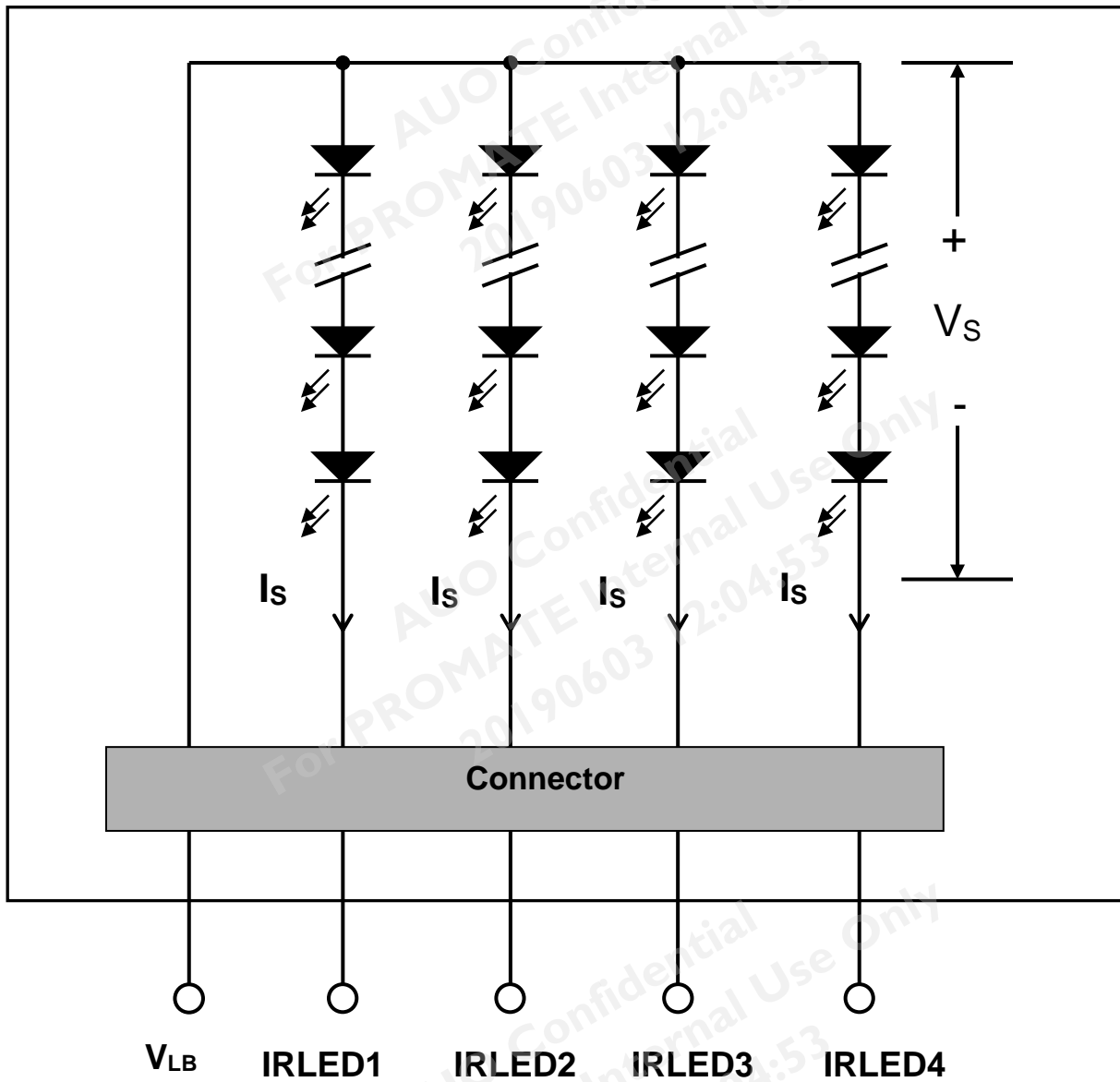

5.2.3 Parameter guideline for LED

Following characteristics are measured under a stable condition using an inverter at 25°C (Room Temperature):

LED characteristics

Symbol	Parameter	Min	Typ	Max	Units	Condition
I _F	LED Forward Current		108	120	mA	Ta = 25°C
V _F LED	Forward Voltage		54	61.2		
P _{LED}	LED Power Consumption	-	26	29.4	Watt	IF =120 mA, Ta = 25°C
LTLED	LED Lifetime	30,000			Hrs	IF=120 mA, Ta= 25°C

Note 1: Calculator value for reference P_{LED} = V_F (Normal Distribution) * I_F (Normal Distribution) / Efficiency

Note 2: The LED life-time define as the estimated time to 50% degradation of initial luminous.

Note 3: If module is driven by high current or at high ambient temperature & humidity condition, the operating life will be reduced.

Note 4: P_{LED}, I_F are defined for LED B/L. (100% duty of PWM dimming)

Note 5: I_F, V_F are defined for one channel LED.

Note 6: Ta means ambient temperature of TFT-LCD module.

Note 7: Each LED light bar consists of 72 pcs LED package (4 strings x 18 pcs / string).

6. Signal Characteristic

6.1 Pixel Format Image

Following figure shows the relationship between input signal and LCD pixel format

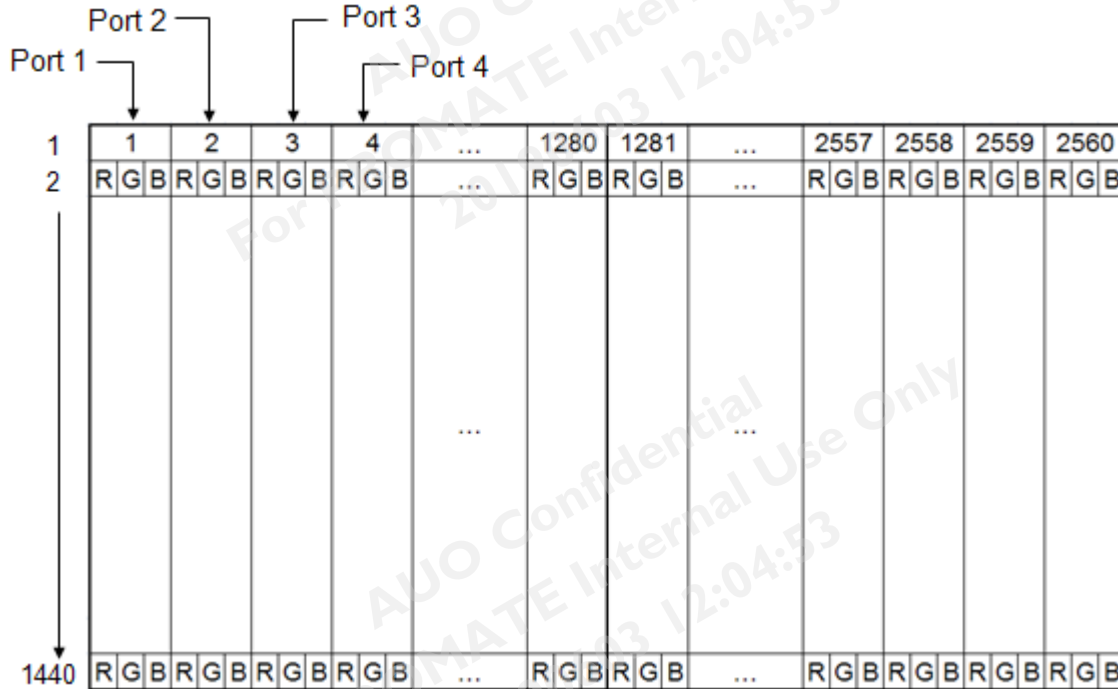

Note 1: The module use 4port-LVDS interface.

Port 1 : $4N+1$ (1, 5.. 2557 pixel)

Port 2 : $4N+2$ (2, 6.. 2558 pixel)

Port 3 : $4N+3$ (3, 7.. 2559 pixel)

Port 4 : $4N+4$ (4, 8.. 2560 pixel)

$N = 0, 1 \sim 639$

6.2 LVDS Data Format

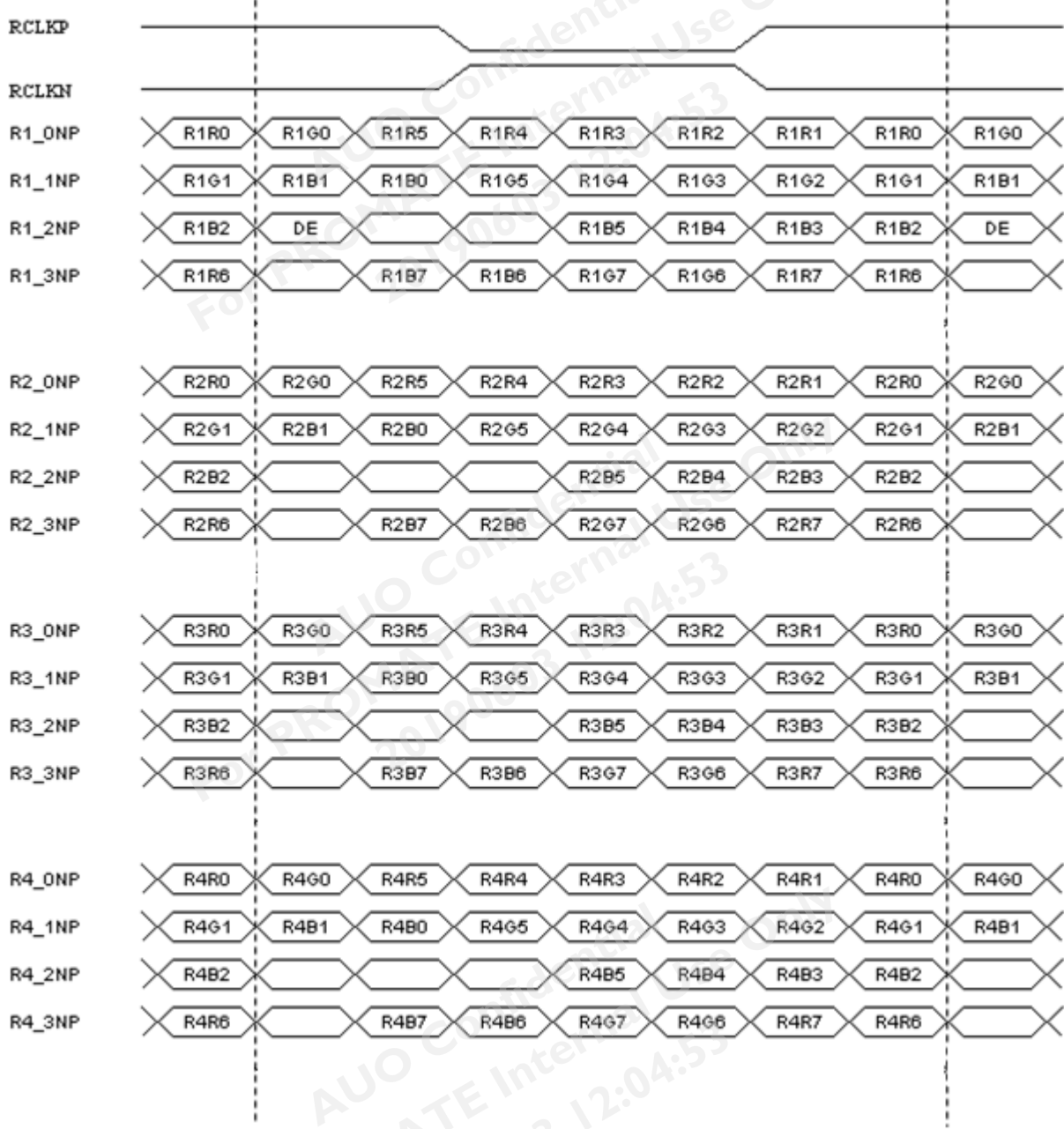

6.3 Signal Description

6.3.1 TFT LCD Module: LVDS Connector

TFT-LCD Connector (CNT1)	Manufacturer	JAE	P-TWO
	Part Number	FI-RE51S-HF	187059-5122
TFT-LCD Connector (CNT2)	Manufacturer	JAE	P-TWO
	Part Number	FI-RE41S-HF	187060-4122
Mating Connector (CNT1)	Manufacturer	JAE	
	Part Number	FI-RE51HL	
Mating Connector (CNT2)	Manufacturer	JAE	
	Part Number	FI-RE41HL	

6.3.2 Connector Pin Assignment

■ LVDS CN1

PIN #	Symbol	Description	Remark
1	NC	No Connection (for AUO test only. Do not connect)	
2	NC	No Connection (for AUO test only. Do not connect)	
3	NC	No Connection (for AUO test only. Do not connect)	
4	NC	No Connection (for AUO test only. Do not connect)	
5	NC	No Connection (for AUO test only. Do not connect)	
6	NC	No Connection (for AUO test only. Do not connect)	
7	NC	No Connection (for AUO test only. Do not connect)	
8	NC	No Connection (for AUO test only. Do not connect)	
9	NC	No Connection (for AUO test only. Do not connect)	
10	NC	No Connection (for AUO test only. Do not connect)	
11	GND	Power Ground	
12	R1_ON	FIRST_ Negative LVDS differential data input	
13	R1_OP	FIRST_ Positive LVDS differential data input	
14	R1_1N	FIRST_ Negative LVDS differential data input	
15	R1_1P	FIRST_ Positive LVDS differential data input	
16	R1_2N	FIRST_ Negative LVDS differential data input	
17	R1_2P	FIRST_ Positive LVDS differential data input	
18	GND	Power Ground	



Product Specification

G270QAN01.0

AU OPTRONICS CORPORATION

19	R1_CLKN	FIRST_ Negative LVDS differential clock input	
20	R1_CLKP	FIRST_ Positive LVDS differential clock input	
21	GND	Power Ground	
22	R1_3N	FIRST_ Negative LVDS differential data input	
23	R1_3P	FIRST_ Positive LVDS differential data input	
24	NC	No Connection (for AUO test only. Do not connect)	
25	NC	No Connection (for AUO test only. Do not connect)	
26	GND	Power Ground	
27	GND	Power Ground	
28	R2_0N	SECOND_ Negative LVDS differential data input	
29	R2_0P	SECOND_ Positive LVDS differential data input	
30	R2_1N	SECOND_ Negative LVDS differential data input	
31	R2_1P	SECOND_ Positive LVDS differential data input	
32	R2_2N	SECOND_ Negative LVDS differential data input	
33	R2_2P	SECOND_ Positive LVDS differential data input	
34	GND	Power Ground	
35	R2_CLKN	SECOND_ Negative LVDS differential clock input	
36	R2_CLKP	SECOND_ Positive LVDS differential clock input	
37	GND	Power Ground	
38	R2_3N	SECOND_ Negative LVDS differential data input	
39	R2_3P	SECOND_ Positive LVDS differential data input	
40	NC	No Connection (for AUO test only. Do not connect)	
41	NC	No Connection (for AUO test only. Do not connect)	
42	GND	Power Ground	
43	GND	Power Ground	
44	GND	Power Ground	
45	NC	No connection (for AUO test only. Do not connect)	
46	VDD	Power +5V	
47	VDD	Power +5V	
48	VDD	Power +5V	
49	VDD	Power +5V	
50	VDD	Power +5V	
51	VDD	Power +5V	



■ LVDS CN2

PIN #	Symbol	Description	Remark
1	NC	No Connection (for AUO test only. Do not connect)	
2	NC	No Connection (for AUO test only. Do not connect)	
3	NC	No Connection (for AUO test only. Do not connect)	
4	NC	No Connection (for AUO test only. Do not connect)	
5	NC	No Connection (for AUO test only. Do not connect)	
6	NC	No Connection (for AUO test only. Do not connect)	
7	NC	No Connection (for AUO test only. Do not connect)	
8	NC	No Connection (for AUO test only. Do not connect)	
9	GND	Power Ground	
10	R3_ON	THIRD_ Negative LVDS differential data input	
11	R3_OP	THIRD_ Positive LVDS differential data input	
12	R3_1N	THIRD_ Negative LVDS differential data input	
13	R3_1P	THIRD_ Positive LVDS differential data input	
14	R3_2N	THIRD_ Negative LVDS differential data input	
15	R3_2P	THIRD_ Positive LVDS differential data input	
16	GND	Power Ground	
17	R3_CLKN	THIRD_ Negative LVDS differential clock input	
18	R3_CLKP	THIRD_ Positive LVDS differential clock input	
19	GND	Power Ground	
20	R3_3N	THIRD_ Negative LVDS differential data input	
21	R3_3P	THIRD_ Positive LVDS differential data input	
22	NC	No Connection (for AUO test only. Do not connect)	
23	NC	No Connection (for AUO test only. Do not connect)	
24	GND	Power Ground	
25	GND	Power Ground	
26	R4_ON	FOURTH_ Negative LVDS differential data input	
27	R4_OP	FOURTH_ Positive LVDS differential data input	
28	R4_1N	FOURTH_ Negative LVDS differential data input	
29	R4_1P	FOURTH_ Positive LVDS differential data input	



Product Specification

G270QAN01.0

AU OPTRONICS CORPORATION

30	R4_2N	FOURTH_ Negative LVDS differential data input	
31	R4_2P	FOURTH_ Positive LVDS differential data input	
32	GND	Power Ground	
33	R4_CLKN	FOURTH_ Negative LVDS differential clock input	
34	R4_CLKP	FOURTH_ Positive LVDS differential clock input	
35	GND	Power Ground	
36	R4_3N	FOURTH_ Negative LVDS differential data input	
37	R4_3P	FOURTH_ Positive LVDS differential data input	
38	NC	No Connection (for AUO test only. Do not connect)	
39	NC	No Connection (for AUO test only. Do not connect)	
40	GND	Power Ground	
41	GND	Power Ground	

AUO Confidential
For PROMATE Internal Use Only
20190603 12:04:53

6.4 Interface Timing

6.4.1 Timing Characteristics

Symbol	Description	Min.	Typ.	Max.	Unit	Remark	
Tv	Vertical Section	Period	1452	1481	2299	Th	
Tdisp (v)		Active	1440	1440	1440	Th	
Tblk (v)		Blanking	12	41	859	Th	
Fv		Frequency	49	60	76	Hz	
Th	Horizontal Section	Period	679	680	1023	Tclk	
Tdisp (h)		Active	640	640	640	Tclk	
Tblk (h)		Blanking	39	40	383	Tclk	
Fh		Frequency	71.3	88.8	112.6	KHz	Note 6-1
Tclk	LVDS Clock	Period	13.1	16.6	20.6	ns	1/Fclk
Fclk		Frequency	48.4	60.4	76.5	MHz	Note 6-2

DE mode only

Note 6-1: The equation is listed as following. Please don't exceed the above recommended value.

$$\begin{aligned} Fh (\text{Min.}) &= Fclk (\text{Min.}) / Th (\text{Min.}); \\ Fh (\text{Typ.}) &= Fclk (\text{Typ.}) / Th (\text{Typ.}); \\ Fh (\text{Max.}) &= Fclk (\text{Max.}) / Th (\text{Min.}); \end{aligned}$$

Note 6-2: The equation is listed as following. Please don't exceed the above recommended value.

$$\begin{aligned} Fclk (\text{Min.}) &= Fv (\text{Min.}) \times Th (\text{Min.}) \times Tv (\text{Min.}); \\ Fclk (\text{Typ.}) &= Fv (\text{Typ.}) \times Th (\text{Typ.}) \times Tv (\text{Typ.}); \\ Fclk (\text{Max.}) &= Fv (\text{Max.}) \times Th (\text{Typ.}) \times Tv (\text{Typ.}); \end{aligned}$$

6.4.2 Input Timing Diagram

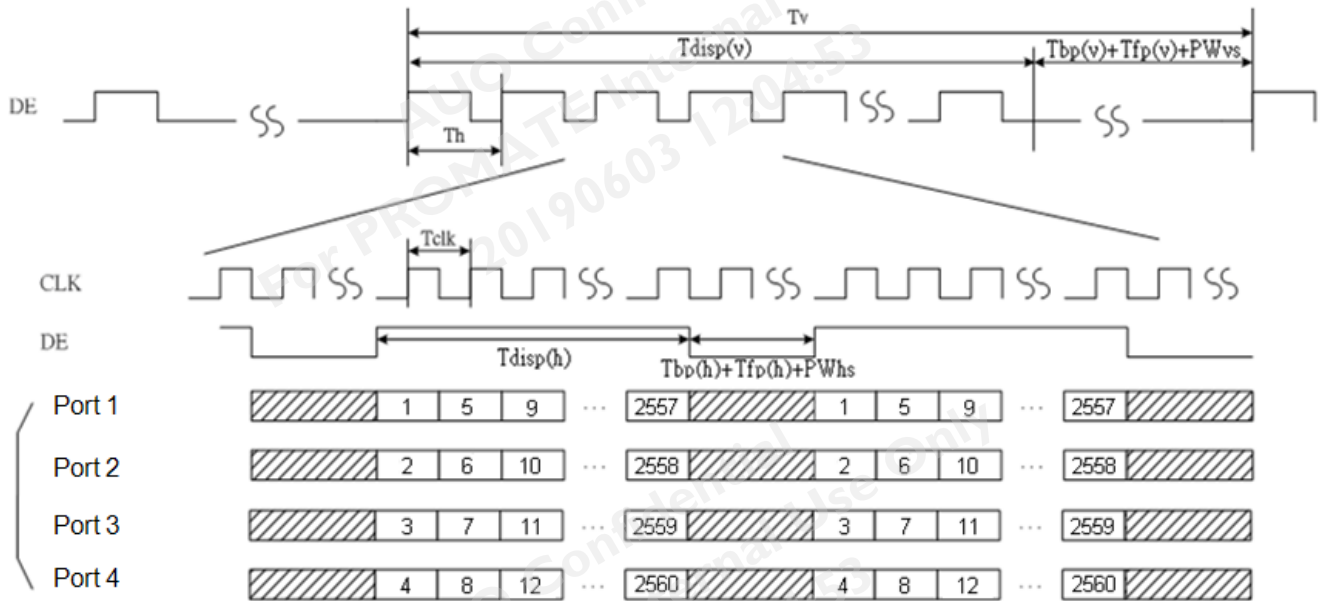

AUO Confidential
 For PROMATE Internal Use Only
 20190603 12:04:53

6.5 Power ON/OFF Sequence

VDD power, LVDS signal and backlight on/off sequence are as following. LVDS signals from any system shall be Hi-Z state when VDD is off.

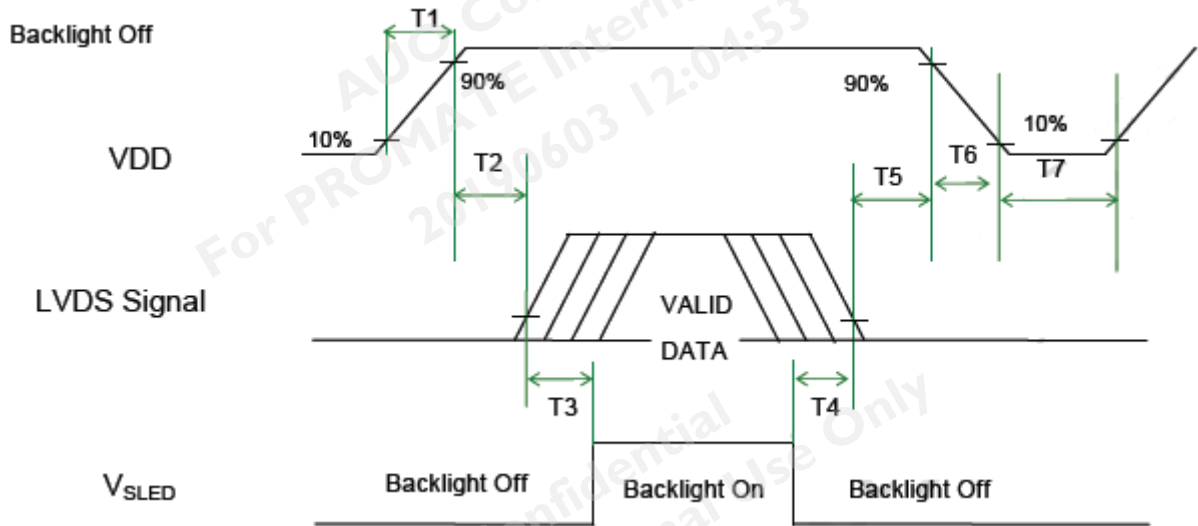

Power ON/OFF sequence timing

Parameter	Value			Units	Remark
	Min.	Typ.	Max.		
T1	0.5	-	10	[ms]	
T2	0	-	50	[ms]	
T3	500	-	--	[ms]	
T4	100	-	-	[ms]	
T5	0	-	50	[ms]	Note 6-4 Note 6-5
T6	0	-	200	[ms]	Note 6-4 Note 6-5
T7	1000	-	-	[ms]	

Note 6-3: Recommend setting T5=0ms to avoid electronic noise when VDD is off.

Note 6-4: During T5 and T6 Period, Please keep the level of input LVDS signals with Hi-Z state.

Note 6-5: Voltage of VDD must decay smoothly after power-off.(customer system decide this value)

7. Reliability Test Criteria

Items	Required Condition	Note
Temperature Humidity Bias (THB)	Ta= 50°C, 80%RH, 300hours	
High Temperature Operation (HTO)	Ta= 50°C, 300hours	
Low Temperature Operation (LTO)	Ta= 0°C, 300hours	
High Temperature Storage (HTS)	Ta= 60°C, 300hours	
Low Temperature Storage (LTS)	Ta= -20°C, 300hours	
Vibration Test (Non-operation)	Acceleration: 1.5 G Wave: Random Frequency: 10 - 200 Hz Sweep: 30 Minutes each Axis (X, Y, Z)	
Shock Test (Non-operation)	Acceleration: 50 G Wave: Half-sine Active Time: 20 ms Direction: ±X, ±Y, ±Z (one time for each Axis)	
Drop Test	Height: 60 cm, package test	
Thermal Shock Test (TST)	-20 °C /30min, 60/°C 30min, 100 cycles	1
On/Off Test	On/10sec, Off/10sec, 30,000 cycles	
ESD (Electrostatic Discharge)	Contact Discharge: ± 8KV, 150pF(330Ω) 1sec, 9 points, 25 times/ point.	2
	Air Discharge: ± 15KV, 150pF(330Ω) 1sec 9 points, 25 times/ point.	
Altitude Test	Operation:10,000 ft Non-Operation:30,000 ft	

Note 1: The TFT-LCD module will not sustain damage after being subjected to 100 cycles of rapid temperature change. A cycle of rapid temperature change consists of varying the temperature from -20°C to 50°C, and back again. Power is not applied during the test. After temperature cycling, the unit is placed in normal room ambient for at least 4 hours before power on.

Note 2: According to EN61000-4-2 , ESD class B: Some performance degradation allowed. No data lost. Self-recoverable. No hardware failures.

Note 3:

- Water condensation is not allowed for each test items.
- Each test is done by new TFT-LCD module. Don't use the same TFT-LCD module repeatedly for reliability test.
- The reliability test is performed only to examine the TFT-LCD module capability.
- To inspect TFT-LCD module after reliability test, please store it at room temperature and room humidity for 24 hours at least in advance.
- No function failure occurs.

8. Mechanical Characteristics

8.1 LCM Outline Dimension

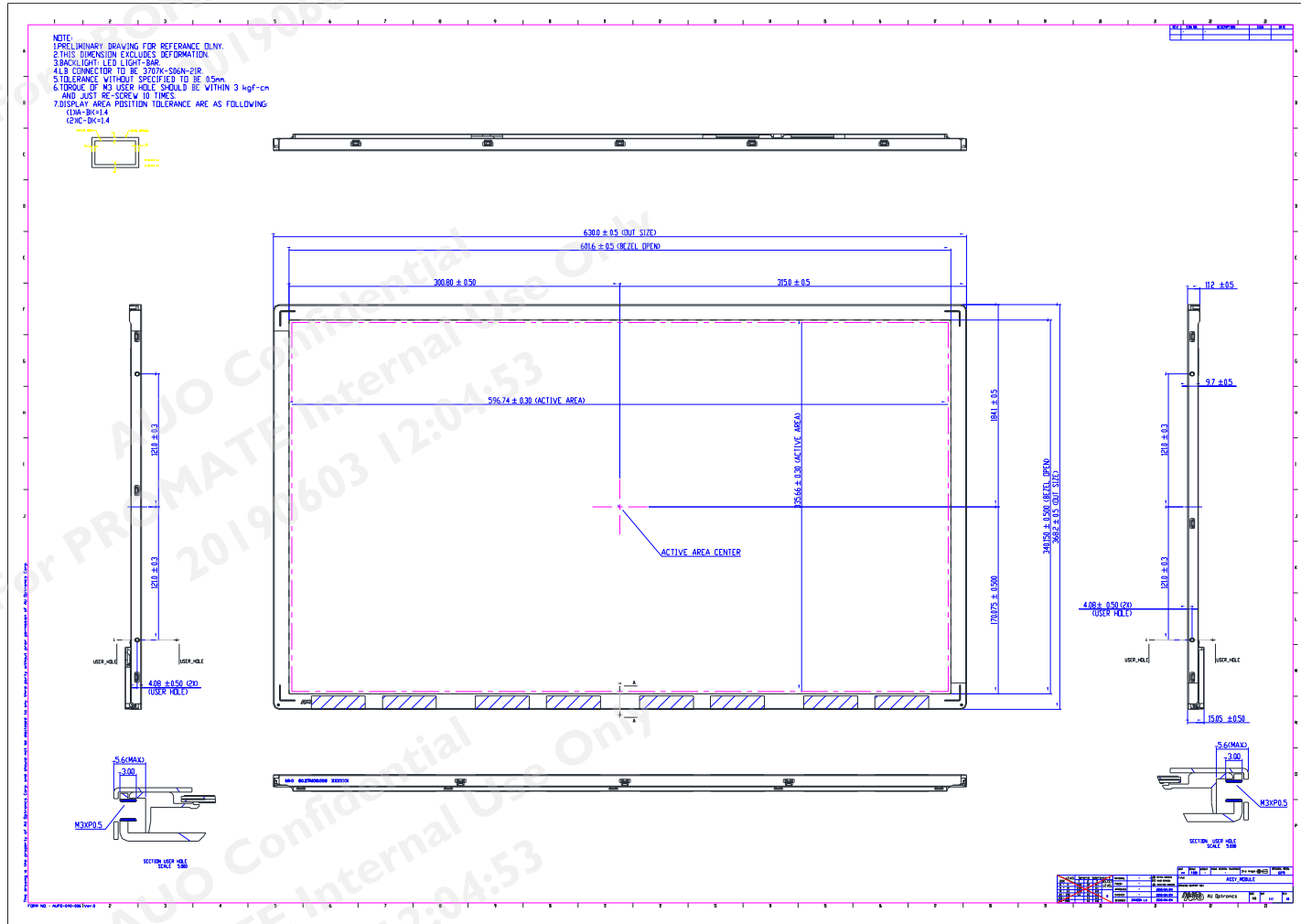



Product Specification

AU OPTRONICS CORPORATION

G270QAN01.0

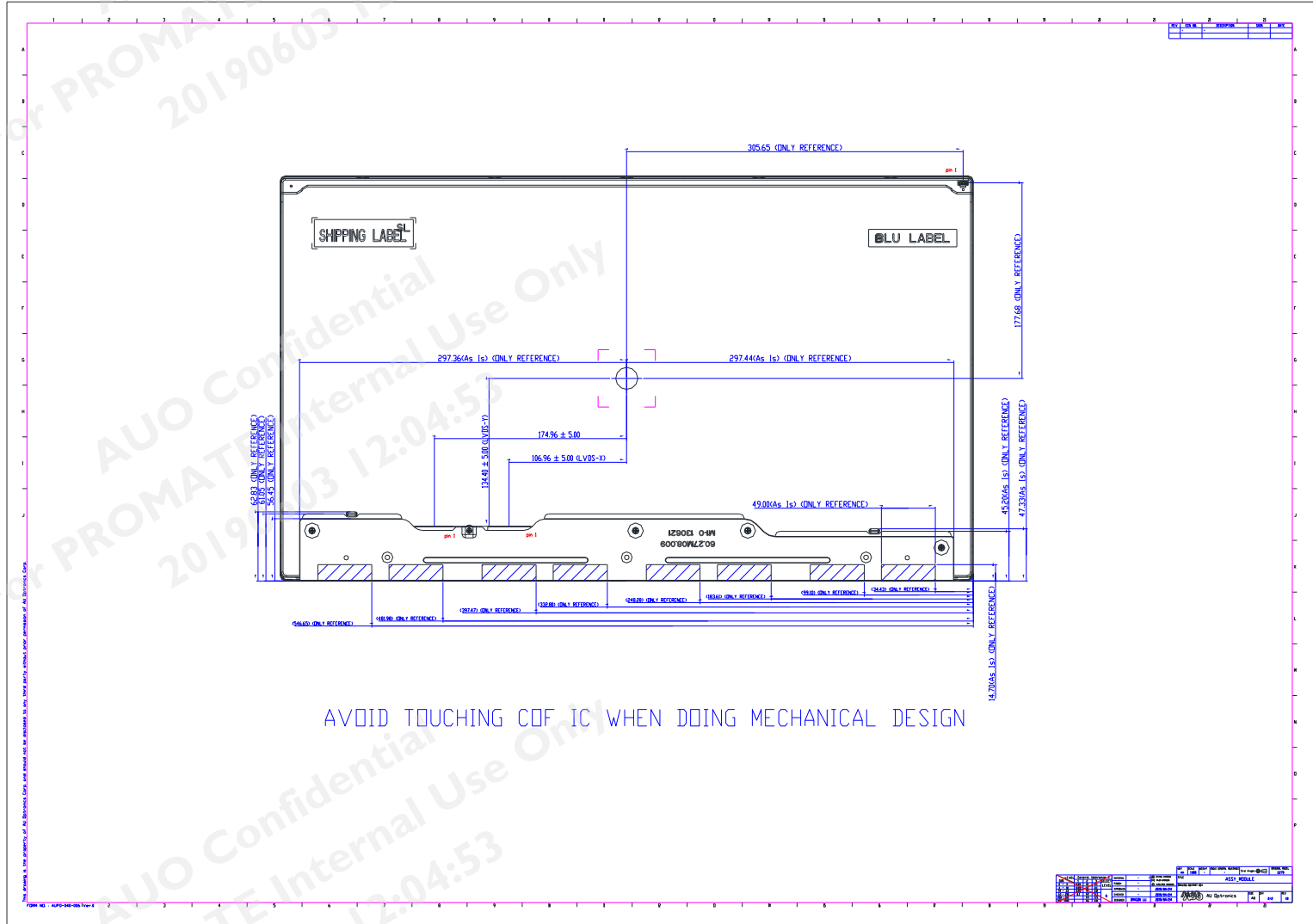

9. Label and Packaging

9.1 Shipping Label (on the rear side of TFT-LCD display)

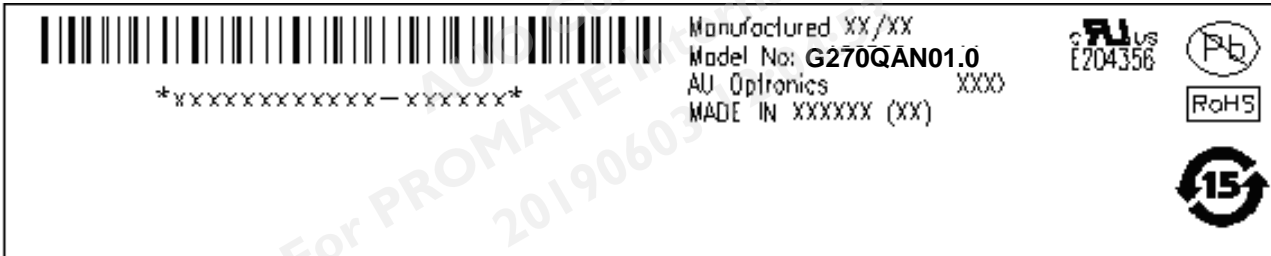

Note 1: For Pb Free products, AUO will add for identification.

Note 2: For RoHS compatible products, AUO will add for identification.

Note 3: For China RoHS compatible products, AUO will add for identification.

Note 4: The Green Mark will be presented only when the green documents have been ready by AUO Internal Green Team.

9.2 Carton Package

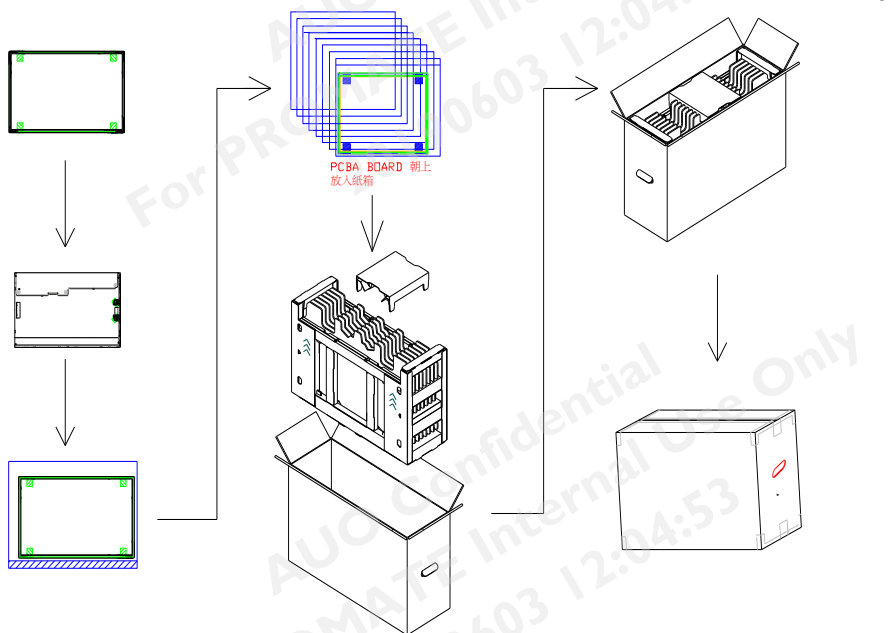

Max capacity : 8 PCS TFT-LCD module per carton

Max weight : 28.6 kg per carton

Outside dimension of carton : 735mm(L)* 258mm(W)*480mm(H)

Pallet size : 1060 mm * 760 mm * 132mm

Box stacked

Module by air_Max : (1*4) *2 layers , one pallet put 8 boxes , total 64pcs module

Module by sea_Max : (1*4) *2 layers + (1*4) *2 layers , two pallet put 16 boxes , total 128pcs module

Module by sea_HQ_Max : (1*4) *2 layers+(1*4) *2 layers, two pallet put 16 boxes, total 128pcs module



10 Safety

10.1 Sharp Edge Requirements

There will be no sharp edges or comers on the display assembly that could cause injury.

10.2 Materials

10.2.1 Toxicity

There will be no carcinogenic materials used anywhere in the display module. If toxic materials are used, they will be reviewed and approved by the responsible AUO toxicologist.

10.2.2 Flammability

All components including electrical components that do not meet the flammability grade UL94-V1 in the module will complete the flammability rating exception approval process.

The printed circuit board will be made from material rated 94-V1 or better. The actual UL flammability rating will be printed on the printed circuit board.

10.3 Capacitors

If any polarized capacitors are used in the display assembly, provisions will be made to keep them from being inserted backwards.

10.4 National Test Lab Requirement

The display module will satisfy all requirements for compliance to:
UL 60950-1 second edition U.S.A. Information Technology Equipment