

DOCUMENT NUMBER AND REVISION
VL-PS-COG-CHSDT005-01 REV.A
(COG-CHSDT005-01)

DOCUMENT TITLE:
PRELIMINARY SPECIFICATION
OF
TFT MODULE TYPE

CUSTOMER	
CUSTOMER REFERENCE NO.	
MODEL NUMBER	COG-CHSDT005-01
REFERENCE NO.	AV123Z7M-N18-5DP1
CUSTOMER APPROVAL	
DATE	

DISTRIBUTION LIST: MARKETING



PRODUCT GROUP

REV

ISSUE DATE

TFT LCD PRODUCT

A

2019.10.23

12.3inch MDL Product Full-Specification
Rev. A

HEFEI BOE XINSHENG OPTOELECTRONICS TECHNOLOGY

SPEC. NUMBER

SPEC TITLE

PAGE

AV123Z7M-N18-5DP1

1 OF 21

BOE	PRODUCT GROUP	REV	ISSUE DATE
	TFT LCD PRODUCT	A	2019.10.23

REV.	ECN NO.	DESCRIPTION OF CHANGES	DATE	PREPARED
A	-	Initial Release	2019.10.23	Dong Hao

SPEC. NUMBER	SPEC TITLE AV123Z7M-N18-5DP1	PAGE 2 OF 21
--------------	---------------------------------	-----------------

Contents

No.	Items	Page
1.0	General Description	4
2.0	Absolute Maximum Ratings	6
3.0	Electrical Specifications.	7
4.0	Optical Specifications.	9
5.0	Optical Test Appendix	11
6.0	Mechanical Characteristics	13
7.0	MDL Outline Dimension	14
8.0	Reliability Test	15
9.0	Interface Connection	16
10.0	Signal Specification	19
11.0	Power on/off Sequence	20
12.0	Package	21

1.0 GENERAL DESCRIPTION

1.1 Introduction

12.3inch module is a color active matrix TFT LCD module using amorphous silicon TFT's (Thin Film Transistors) as an active switching devices. It is a transmissive type display operating in the normal black. The TFT-LCD has a 12.3 inch diagonally measured active area with resolutions (1920 horizontal by 720 vertical pixel arrays). Each pixel is divided into RED, GREEN, BLUE dots which are arranged in vertical stripe and this panel can display 16.7M colors.

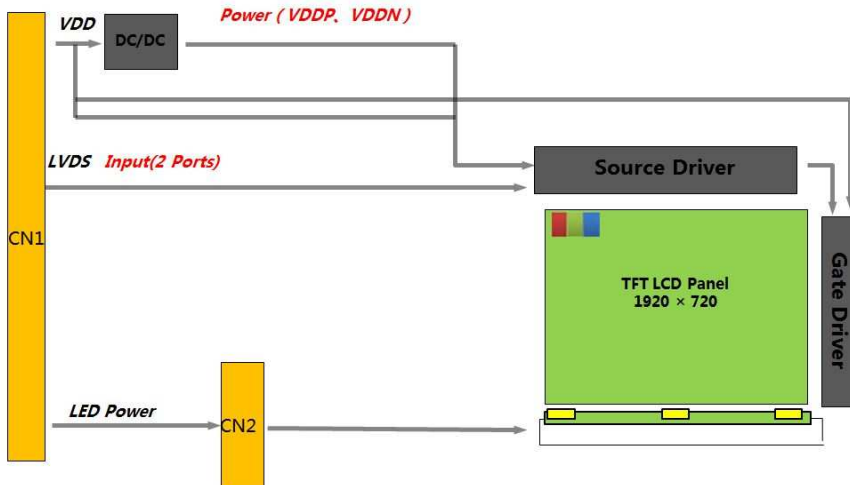

Figure 1-1 Block Diagram

1.2 Features

- Wide viewing angle (U/D/L/R) : 88/88/88/88
- Color Gamut : 75%
- Cell thickness : 1.0t
- LVDS Interface

1.3 Application

- Vehicle-mounted Production

1.4 General Specification

<Table 1-1 General Specifications>

Parameter	Specification	Unit	Remarks
Active area	292.032 (H) × 109.512 (V)	mm	8 : 3
Number of pixels	1920(H) × 720(V)	pixels	
Pixel pitch	0.1521(H) × RGB × 0.1521 (V)	mm	
Pixel arrangement	RGB Vertical stripe		
Display colors	16.7M	colors	
Color gamut	75%	%	Typ.
Display mode	Normally black		
Module outline	307(H) x 126 (V)	mm	
Viewing Direction (Human Eye)	U/D/L/R Min 80/80/80/80 Typ 88/88/88/88		
Driver IC	3*RM5366A 1*RM57861		3S+1G Raydium

Note:

1. At the U/D/L/R direction, the viewing angle is same;
2. The TFT and CF Align Direction;



Figure 1-2 The TFT and CF Align Direction

BOE	PRODUCT GROUP	REV	ISSUE DATE
	TFT LCD PRODUCT	A	2019.10.23

2.0 ABSOLUTE MAXIMUM RATINGS

The followings are maximum values which, if exceed, may cause faulty operation or damage to the unit. The operational and non-operational maximum voltage and current values are listed in Table 2-1

< Table 2-1 Environment Absolute Maximum Ratings >

Parameter	Symbol	Min.	Max.	Unit	Remarks
LC operating Voltage *1)	V _{OP}	-	5.7	V	Ta=25+/-2°C
Operating Temperature (Humidity)	T _{OP}	-40	+85	°C	
	RH	-	90	%	At 60°C
Storage Temperature (Humidity)	T _{ST}	-40	+90	°C	
	RH	-	90	%	At 60°C

*1)Liquid Crystal driving voltage

Due to the characteristics of LC Material, this voltage varies with environmental temperature.

SPEC. NUMBER	SPEC TITLE AV123Z7M-N18-5DP1	PAGE 6 OF 21
--------------	---------------------------------	-----------------

3.0 ELECTRICAL SPECIFICATIONS

3.1 Electrical Specifications

Ta=25+/-2°C

Parameter	Symbol	Values			Unit	Notes
		Min	Typ.	Max		
TFT Gate ON Voltage	VGH	16	-	18	V	
TFT Gate OFF Voltage	VGL	-15	-	-11	V	
TFT Common Electrode Voltage	VCOM	-3	-	0	V	TBD
Voltage of VCC		3	-	3.5	V	
Current of VCC		150	-	550	mA	
Supply current of LED backlight	Per string			90	mA	9 LED
Total Supply current of LED Backlight	I _{LED} Total			360	mA	4 strings
Supply voltage of LED backlight	Per string	23.7	27.27	30.1	V	4 strings

Notes :

- 1: AVDD should be set to satisfy the characteristic of LC .
- 2: VGH should be set to satisfy charging ratio of TFT pixel.
- 3: VCOM should be adjusted to make the flicker level be minimum and optimize display quality.
- 4: Frame rate=60HZ
- 5: BLU LED : 灯共36颗, 4并9串, 电流值max 360mA, 每串max 90mA

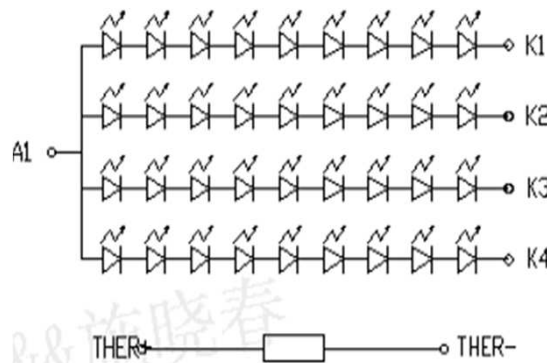

LED: JA. ZF3014W65P01
 NTC: NCP15XH103F0SRC

Figure 3-1 LED&NTC Diagram

3.2 BLU PIN定义：

插接端连接器型号：196415-12041-36

< Table 3-1 Update the definition of BLU LED pin

1	LED-A	LED Anode
2	LED-A	LED Anode
3	LED-A	LED Anode
4	LED-A	LED Anode
5	NC	No Connection
6	NTC1	NTC thermistor terminal 1
7	NTC2	NTC thermistor terminal 2
8	NC	No Connection
9	LED-K1	LED string 1 Cathode
10	LED-K2	LED string 2 Cathode
11	LED-K3	LED string 3 Cathode
12	LED-K4	LED string4 Cathode

4.0 OPTICAL SPECIFICATION

4.1 Overview

The test of Optical specifications shall be measured in a dark room (ambient luminance ≤ 1 lux and temperature = $25 \pm 2^\circ\text{C}$) with the equipment of Luminance meter system (Goniometer system and TOPCON BM-5) and test unit shall be located at an approximate distance 50cm from the LCD surface at a viewing angle of θ and Φ equal to 0° . The center of the measuring spot on the Display surface shall stay fixed.

The backlight should be operating for 30 minutes prior to measurement.

<Table 4-1 Optical Specifications>

Parameter		Symbol	Condition	Min.	Typ.	Max.	Unit	Remark
Viewing Angle range	Horizontal	Θ_3	CR > 10	80	88	-	Deg.	Note 1
		Θ_9		80	88	-	Deg.	
	Vertical	Θ_{12}		80	88	-	Deg.	
		Θ_6		80	88	-	Deg.	
Luminance Contrast ratio		CR	$\Theta = 0^\circ$ (Center) Normal Viewing Angle	-	1000	-		
White luminance uniformity		ΔY		75	-		%	Note 4
NTSC		%			75%			
White Chromaticity		x_w		Typ-0.03	Typ+0.03	0.292	-	Note 5
		y_w	0.325			-		
Reproduction of color	Red	x_R	0.650			-		
		y_R	0.328			-		
	Green	x_G	0.316			-		
		y_G	0.628			-		
	Blue	x_B	0.150			-		
		y_B	0.059			-		
Response Time (Rising / Falling)		T_{RT}	25 $^\circ\text{C}$ -20 $^\circ\text{C}$ -30 $^\circ\text{C}$	-	25 - -	35 250 600	ms	Note 6
BLU Derating		T	67	-	-	30%		F 5-4

Parameter	Condition	Min.	Typ.	Max.	Remark
Luminance	$\Theta = 0^\circ$ (Center) Normal Viewing Angle	700	850	-	1 BEF (10°) + 1 DBEF
Flicker		-	-	-20dB	The customer did not specify inspection criteria

Note :

- Viewing angle is the angle at which the contrast ratio is greater than 10. The viewing are determined for the horizontal or 3, 9 o'clock direction and the vertical or 6, 12 o'clock direction with respect to the optical axis which is normal to the LCD surface.
- Contrast measurements shall be made at viewing angle of $\theta = 0^\circ$ and at the center of the LCD surface. Luminance shall be measured with all pixels in the view field set first to white, then to the dark (black) state. (See FIGURE 1 shown in Appendix) Luminance Contrast Ratio (CR) is defined mathematically.

$$CR = \frac{\text{Luminance when displaying a white raster}}{\text{Luminance when displaying a black raster}}$$

- Center trans of white is defined as the LCD surface. Luminance shall be measured with all pixels in the view field set first to white. This measurement shall be taken at the locations shown in FIGURE 4 for a total of the measurements per display.
- The White luminance uniformity on LCD surface is then expressed as :
 $\Delta Y = (\text{Minimum Luminance of 9points} / \text{Maximum Luminance of 9points}) * 100$
- The color chromaticity coordinates specified in Table 4. shall be calculated from the spectral data measured with all pixels first in red, green, blue and white. Measurement condition is C - light source.
- The electro-optical response time measurements shall be made as FIGURE 5 shown in Appendix by switching the "data" input signal ON and OFF. The times needed for the transmittance to change from 10% to 90% is Tr, and 90% to 10% is Tf.

5.0 OPTICAL TEST APPENDIX

Figure 5-1 The Definition of Vth & Vsat

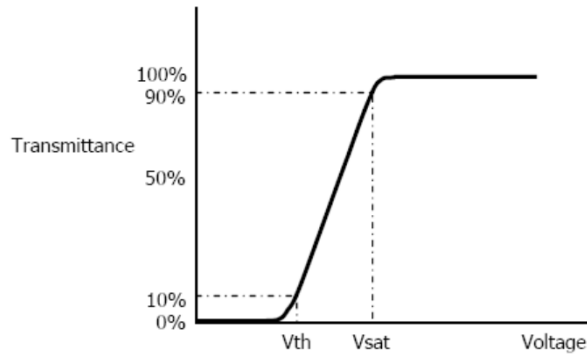

Figure 5-2 Measurement Set Up

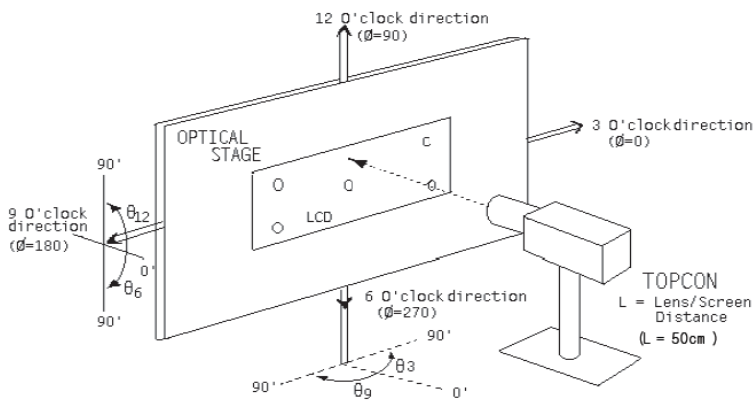

Figure 5-3 Response Time Testing

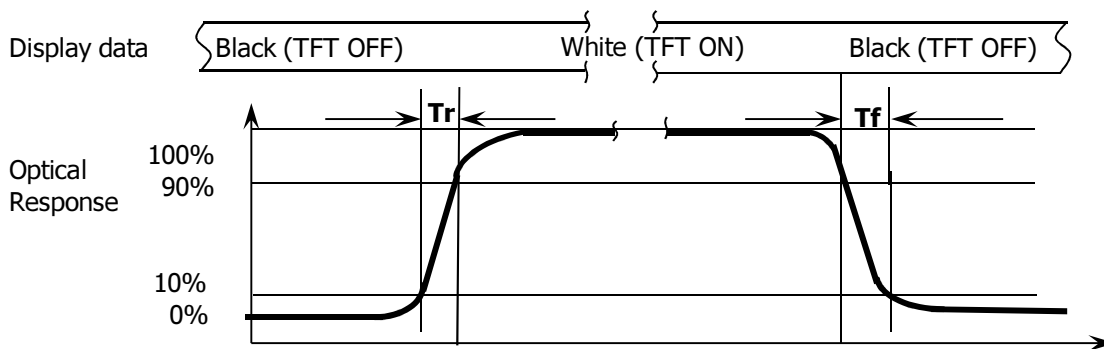
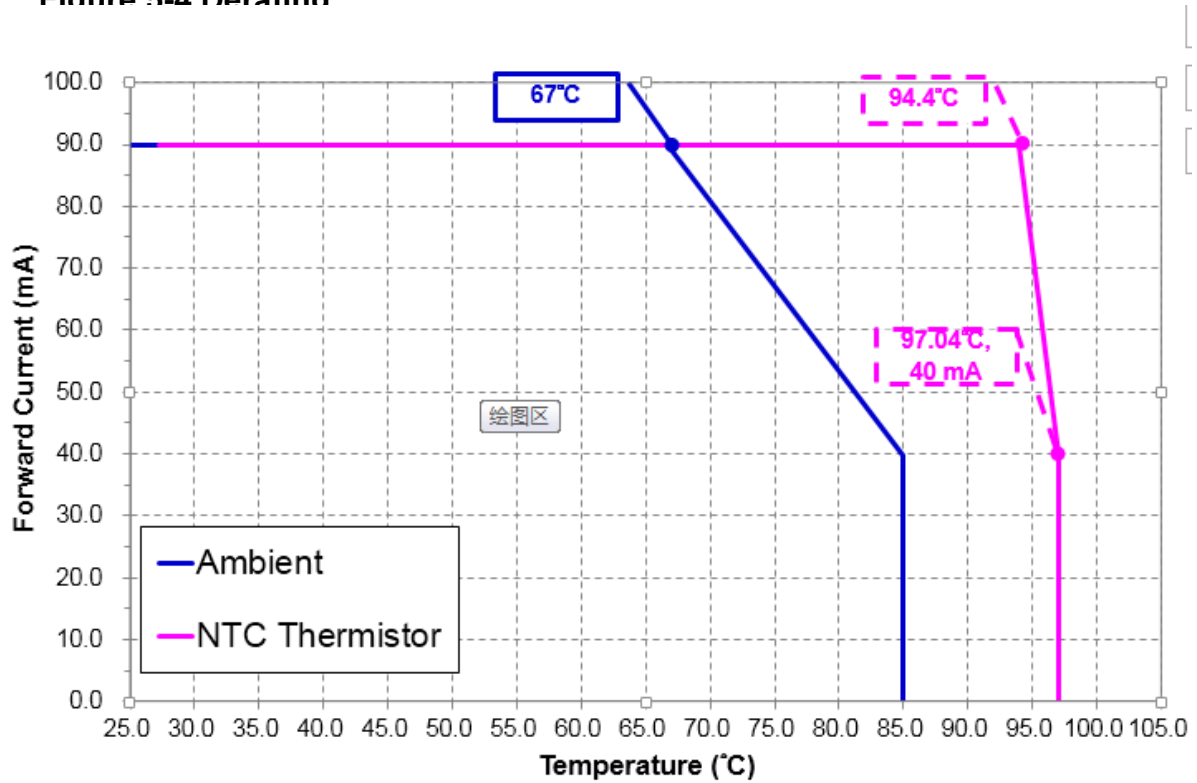

Figure 5-4 Derating



Remark: The plot just for reference , simulation based on similar product. The final result is based on the actual measurement of the final product.

NCP15XH103F0SRB

TEMP. (deg. C)	RESISTANCE (k ohm)
-40	195.6520
-35	148.1710
-30	113.3471
-25	87.5588
-20	68.2367
-15	53.6496
-10	42.5062
-5	33.8922
0	27.2186
+5	22.0211
+10	17.9255
+15	14.6735
+20	12.0805
+25	10.0000
+30	8.3145
+35	6.9479
+40	5.8336
+45	4.9169
+50	4.1609
+55	3.535
+60	3.0143
+65	2.5861
+70	2.2275
+75	1.9245
+80	1.6685
+85	1.4521

6.0 MECHANICAL CHARACTERISTICS

6.1 Dimensional Requirements

Figure in next page shows mechanical outlines for the panel

<Table 6-1 Dimensional Parameters>

Parameter	Specification	Unit
Active Area	292.032 (H) × 109.512 (V)	mm
Number of pixels	1920(H) × 720(V)	Pixels
Pixel pitch	0.1521(H) × RGB × 0.1521 (V)	mm
Pixel arrangement	RGB Vertical stripe	
Display colors	16.7M	colors
Display mode	Normally black	
Module thickness	7.2 / 10.7	mm
Module outline	307x126	mm
AA-MDL outline L/R/U/D	9.068/5.9/5.5/10.988	mm

7.0 MDL Outline Dimension AV123Z7M-N18-DDP1

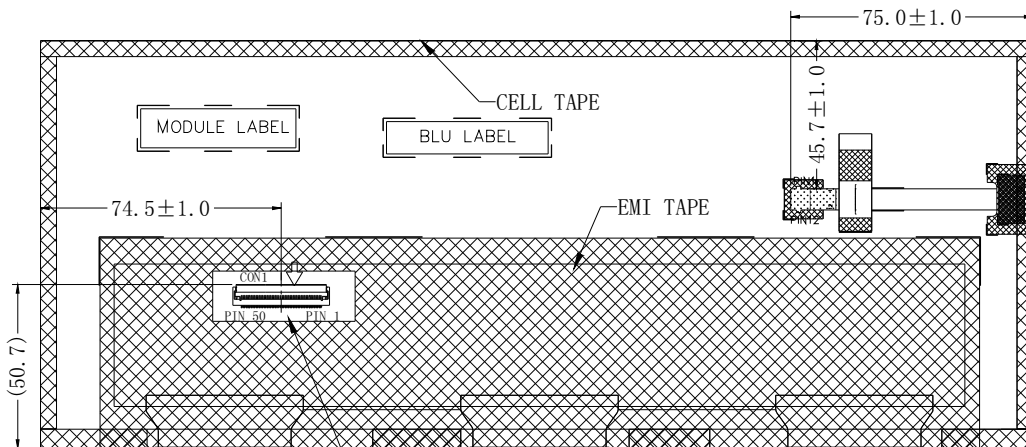
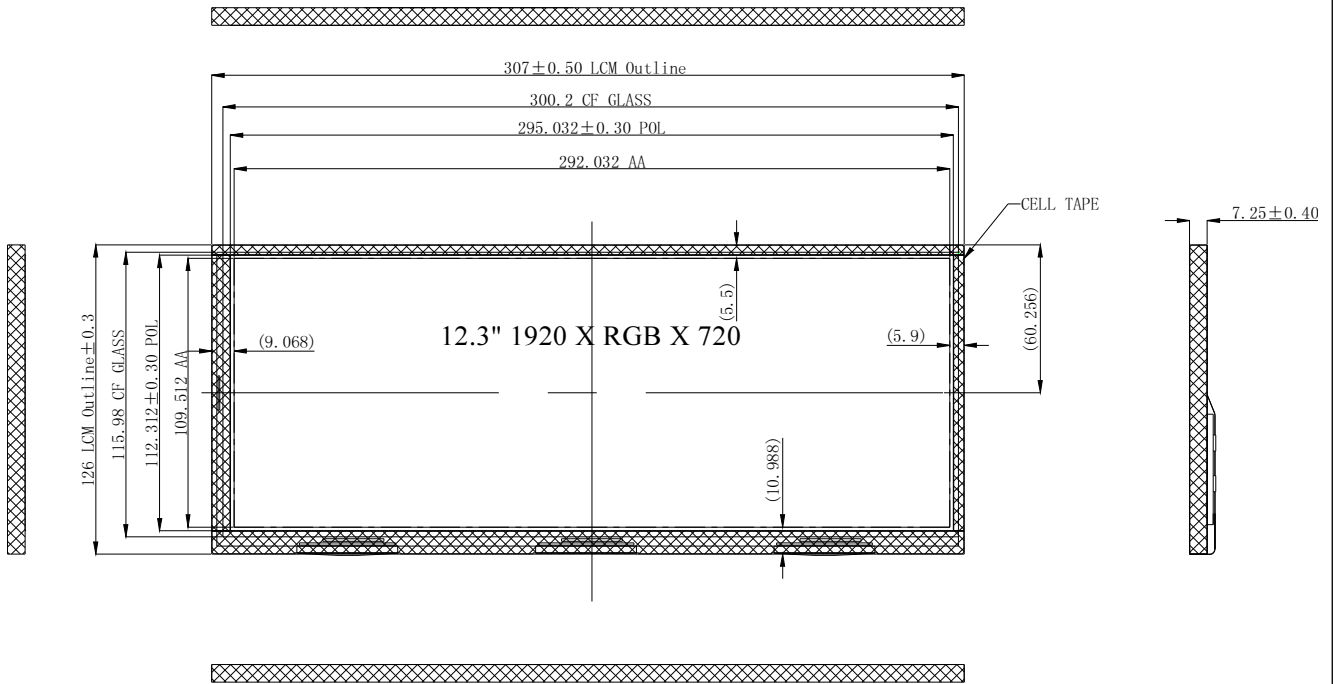

连接器型号为 **FH28-50S-0.5SH (0.5)**

BLU LED:36颗灯, 4并9串, 电流值max 360mA, 每串max90mA

Unit : mm

SPEC. NUMBER

SPEC TITLE

PAGE

AV123Z7M-N18-5DP1

15 OF 21

8.0 RELIABILITY TEST

<Table 8-1 Reliability test>

No	Test Items	Conditions	Remark
1	High temperature storage test	Ta = 90 °C, 500 hrs	Note1
2	Low temperature storage test	Ta = -40 °C, 500 hrs	
3	High temperature operation test	Ta = 85 °C, 500 hrs	
4	Low temperature operation test	Ta = -40 °C, 500 hrs	
5	High temperature & high humidity operation test	Ta = 60 °C, 90%RH, 500 hrs	
6	Thermal shock	Ta = -30 °C ↔ 85 °C (0.5 hr), 100 cycle	Non-operation
7	High temp. and endurance test	Ta = 70 °C, 1500 hrs	
8	Image Sticking	6*8 Pattern, 2hrs 65°C check pattern Gray 127, Spec:≤L2 after 5 mins, the mura must be disappeared completely	
9	ESD test (Non-operation)	Air Voltage: ± 8KV Contact Voltage: ± 6KV R: 330Ω C: 150pF 3time	Note2
10	ESD test (operation)	Air Voltage: ± 15KV Contact Voltage: ± 8KV R: 330Ω C: 150pF 3 time	Note2
11	Vibration Test	Random: 0.015G ² /Hz, 5~200Hz -6dB/Octave, 200~400Hz XYZ 8H	

Note 1

1. 测试完成2H后，恢复室温25°C点灯，-30°C~-40°C满足功能性，不保证画质

Note 2

Class B；因为整机ESD水平不仅与模组相关，也与系统相关。此处承诺配合客户整机达到要求，如需要将进行ESD改善。

9.0 INTERFACE CONNECTION

9.1 The LCD Module Electrical Interface Connection

The Recommended connector is [Hirose FH28-50S-0.5SH\(0.5\)](#)

The connector interface pin assignments are listed in Table 9-1

Table 9-1 Pin Assignments for the LCD Connector

PIN	SYMBOL	Description	Remark
1	GND	Ground	
2	VCC	Power supply	
3	VCC	Power supply	
4	VCC	Power supply	
5	VCC	Power supply	
6	GND	Ground	
7	ELV0N	EVEN LVDS Data input 0-	
8	ELV0P	EVEN LVDS Data input 0+	
9	GND	Ground	
10	ELV1N	EVEN LVDS Data input 1-	
11	ELV1P	EVEN LVDS Data input 1+	
12	GND	Ground	
13	ELV2N	EVEN LVDS Data input 2-	
14	ELV2P	EVEN LVDS Data input 2+	
15	GND	Ground	
16	ECLKN	EVEN Negative CLK input	
17	ECLKP	EVEN Positive CLK input	
18	GND	Ground	
19	ELV3N	EVEN LVDS Data input 3-	
20	ELV3P	EVEN LVDS Data input 3+	
21	GND	Ground	
22	OLV0N	ODD LVDS Data input 0-	
23	OLV0P	ODD LVDS Data input 0+	
24	GND	Ground	
25	OLV1N	ODD LVDS Data input 1-	

PIN	SYMBOL	Description	Remark
26	OLV1P	ODD LVDS Data input 1+	
27	GND	Ground	
28	OLV2N	ODD LVDS Data input 2-	
29	OLV2P	ODD LVDS Data input 2+	
30	GND	Ground	
31	OCLKN	ODD Negative CLK input	
32	OCLKP	ODD Positive CLK input	
33	GND	Ground	
34	OLV3N	ODD LVDS Data input 3-	
35	OLV3P	ODD LVDS Data input 3+	
36	GND	Ground	
37	RESET	Reset	
38	STBYB	Standby mode setting pin,active low	
39	GND	Ground	
40	SCL	SCL	
41	CSB	CSB	
42	SDA	SDA	
43	ATREN	Enable auto reload signal	
44	VOTP	OTP Voltage	
45	GND	Ground	
46	LR	Horizontal shift direction selection	Note 1
47	TB	Vertical shift direction selection	Note 1
48	NC	No Connection	
49	FAULT	Output for fail detection	
50	NC	No Connection	

Note 1:

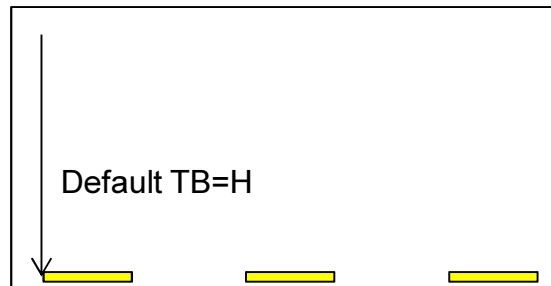
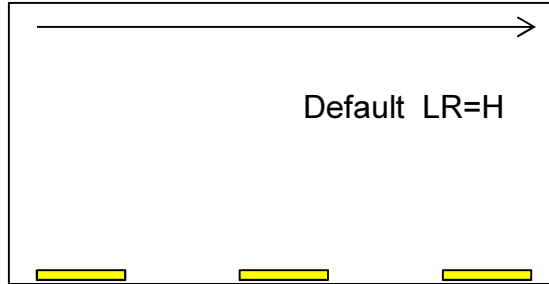

10.0 SIGNAL SPECIFICATION

10.1 LVDS Signal Timing

Table 10-1 LVDS Signal Timing

Parameter	Symbol	Min.	Typ.	Max.	Unit	Condition
Clock frequency	RxFCLK		44.1		MHz	
Horizontal Display Area	thd	960			DCLK	
HS Period	th	989	1002	1248	DCLK	
HS Blanking	Thb+thfp		42		DCLK	
Vertical Display Area	tvd	720			TH	
VS Period	tv	727	733	936	TH	
VS Blanking	Tvbp+tvfp		13		TH	
Clock period	TLVCYC	11.76			ns	
1 data bit time	UI		1/7		TLVCYC	
Clock high time	TLVCH	2.8	4	4.2	UI	
Clock low time	TLVCL	2.8	3	4.2	UI	
LVDS wake-up time	TenLVDS			150	us	

10.2 Signal Format

Table 10-2 Signal Format

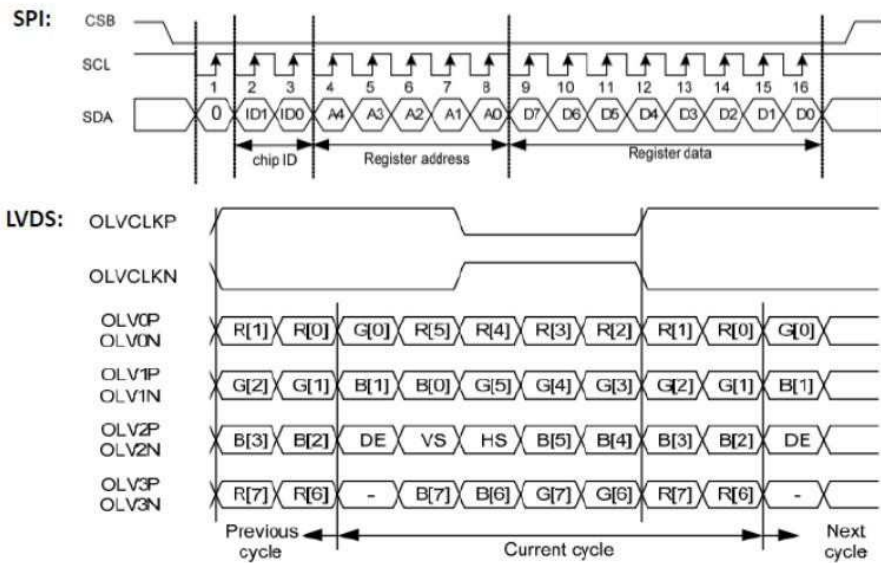

11.0 POWER ON/OFF SEQUENCE

11.1 POWER ON SEQUENCE

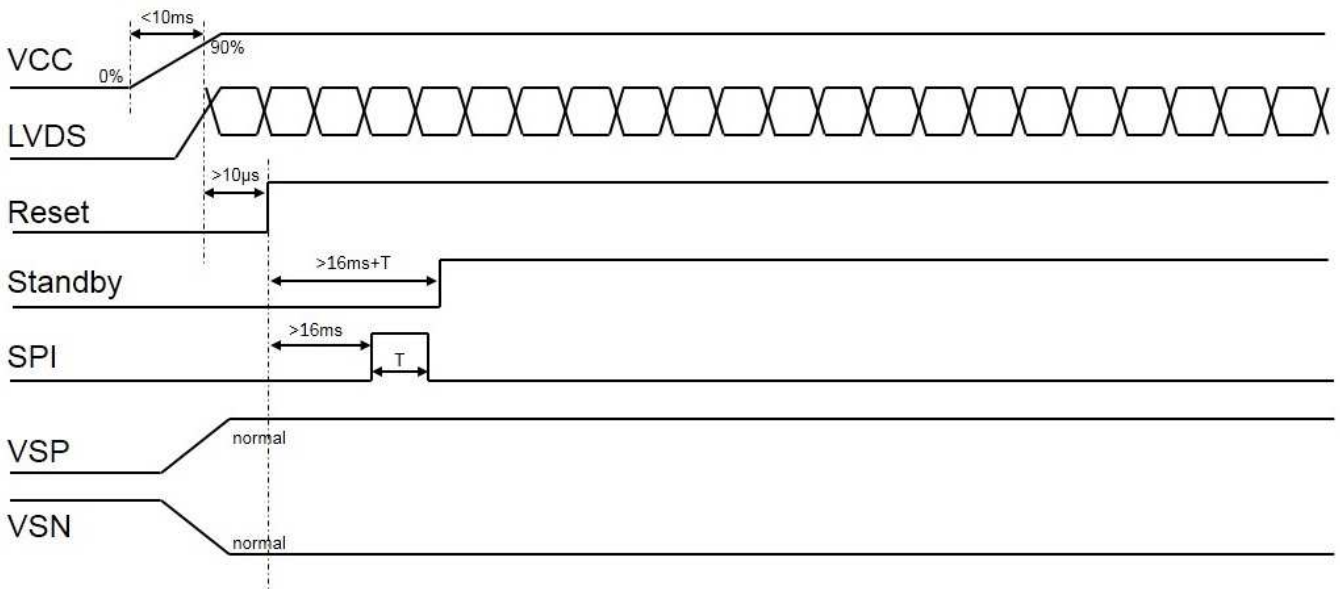

11.2 POWER OFF SEQUENCE

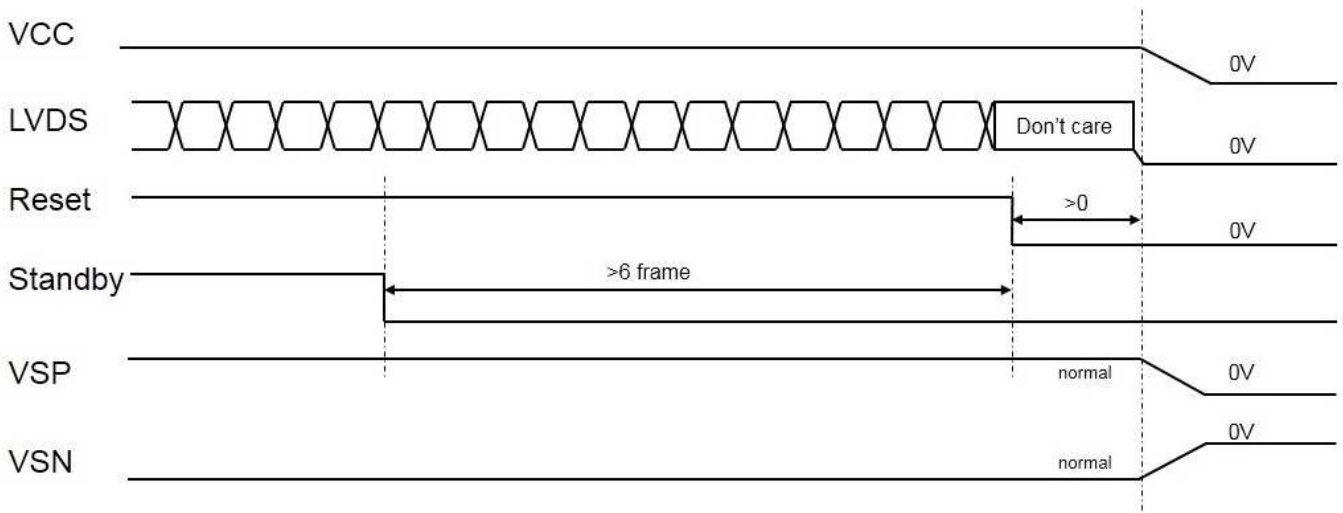

12. Package

12.1. Packing Description

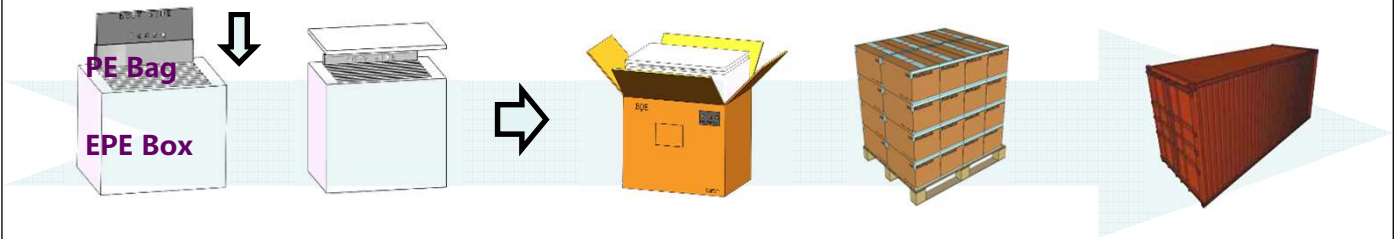

①-. 将1 pcs 贴好硬保的Panel放入PE Bag

注意：1.PCBA侧统一朝下

2.PE Bag开口向显示面折叠，再使用胶纸粘合折叠处

②-. 将1pcs产品横向插入卡槽内

- 将1pcs EPE Cover盖在 EPE Bottom上，将整体装入Box

-容量：8pcs MDL /EPE Box

③-.每个Pallet上4排2列码放，

共堆码4层Box，共计32ea Box

- Pallet外进行护角&缠膜包装

- 容量：256pcs Panel / Pallet

④-.双排双层码放

-容量：52EA Pallet/Truck,

13312 pcs Panel/Truck

BOE**BOE**京东方科技集团股份有限公司
BOE Technology Group Co., Ltd.

页码: - 1/9-

版本 : Rev.1

文件名称

Incoming Inspection Spec For Customer

生效日期 : 2020.5.11

Incoming Inspection Spec Approval Sheet

Product Description: TFT-LCD MDL**BOEXS Product Name:****Customer :** 吉利

Customer Signature	Date	BOE Signature	Date

目录

A: 来料检查基准

1. 介绍
 - 1.1. 范围
 - 1.2. 来料检查权利
 - 1.3. 操作说明
2. 概括
 - 2.1. 抽样方法
 - 2.2. 检查环境
 - 2.3. 定义
3. 检查标准
 - 3.1. 目视检查基准
 - 3.2. 外观检查基准

B: 客户质量服务流程

A: 来料检查基准

1.0 介绍

1.1. 范围

这份 IIS 基准适用于京东方科技集团股份有限公司（下面叫做“供应商”）生产的 TFT-LCD。

1.2. 来料检查权利

买家（顾客）应该在收到 LCD 的 20 天之内（检查期）自费检查。检查结果（接受或是拒绝）应该告知给供应商。买家在商业允许的拒收程序下才能在检查期内拒绝接受全部的 Lot，根据来料标准来判定拒收的 LCD 数量。如果在检查期间买家没有告知供应商结果，那么买家将失去拒收 LCD 的权利，并且会被供应商默认为已经接受了产品。

1.3. 操作说明

1.3.1 操作手法

- LCD 的 Panel 包括两张薄玻璃，非常容易被损坏，所以在处理 LCD 时应该极其小心。
- 施加过多的压力在 LCD 的 Panel 表面是不允许的，务必确保在组装过程中没有扭转力和压缩力作用在 LCD 上。
- 如果是因为客户压力设置出问题，LCD 可能会出现异显情况，但是这个现象不能说明是 LCD 出现故障，最终结果需要经过双方共同确认。
- 根据视觉角度的规格范围确定每个 MDL 的光学组装角度。
- 组装 LCD MDL 时根据组装规格书来。
- 标注放置温湿度条件。

1.3.2 LCD 处理和清洗注意事项

- LCD 的 Panel 包括两张薄玻璃，非常容易被损坏，所以在处理 LCD 时应该极其小心。LCD 是由玻璃制造而成，因此表面不能承受住强烈的机械撞击或是静态的压力，在处理时避免撞击、振动。粗心对待会严重影响产品，如果 LCD 从高处掉落或是受到强烈的撞击，玻璃可能会碎掉。
- Panel 表面的偏光片是由有机物构成，所以要避免化学品接触到偏光片，否则会导致偏光片的损坏。
- 如果无法避免使用了化学品，需用柔软的布条蘸上下面溶液轻轻擦拭 LCD 表面。
-IPA(异丙醇), 乙醇; 不能用干燥、坚硬的材料擦拭 LCD 表面，不然会损坏偏光片和其他部分。不能使用以下溶液擦拭: 水、酮类、芳香类溶液。
- LCD 在装配过程中要用柔软的材料包裹运送，因为 LCD 表面的偏光片极易受到坚硬异物的刮伤而损坏。
- 不要让水、化学品掉落在 LCD 表面。
- 对待 ITO pad 区时要特别小心，因为这部分极易被腐蚀，不能让 HCFC、焊剂、氯、硫、唾液或手指接触到 ITO Pad 区。为了保护这个区域，客户要求 ITO 区域要用 UV 胶或是硅胶覆盖。
- 为避免发生线路断开，不要用超声波清洗 LCD。
- 清洗和烘烤温度应低于 80℃。

1.3.3 静电告诫

- LCD 模组使用 C-MOS LSI 驱动，没用信号的输入都会影响到 Vdd 和 Vss，因此建议客户电源开启前不要输入信号，作业时身体要接地，设备要有防静电装置。
- 撕除 LCD 保护膜要慢，角度大约为 30°，不要垂直于 Panel 表面撕膜；可能的话在离子风

机下, 湿度 50% 下进行以降低静电风险。

- 工作布条应避免使用合成纤维, 应使用棉布或是导电纤维布。
- 接触 LCD 前要戴防静电手套和接地的手脚环并穿上接地的防静电鞋。

1.3.4 操作小心事项

- 在规格电压范围内施加工作电压, 电压超过会缩短 LCD 寿命, 为避免电化学腐蚀应避免使用直流电。
- 不要在电源打开的情况下连接或断开 LCD 与设备。
- 在高温高湿等不正常条件下不要使用 LCD。
- 当 LCD 暴露下强烈气温起伏的环境中 (从热到冷或是从冷到热) 时可能会受到影响, 特别是在从冷到热的强烈气温起伏环境中, 产品表面可能会产生水珠并影响偏光片和 LCD 的功能。
- 温度低于规格范围温度时 LCD 响应时间会变长, 高于规格温度范围会黑屏, 然而这些现象并不意味着 LCD 有故障, 回归正常温度范围后 LCD 会变正常。
- 由于 LCD 结构原因, 不能长时间显示一个固定模式, 会造成残像; 如果屏幕显示为多种模式, 请添加一个屏幕保护程序。
- ESD 会损坏 Panel, 确保作业员在作业过程中佩戴防静电手套, 并且在作业过程中工作台和设备要有效接地。
- 将 LCD 放在 BOE Tray 盘中转运, 以防止机械损伤。
- LCD 应该被存储在要求的湿度环境下, 低湿度会导致静电, 高湿度会导致 ITO 腐蚀。
- 使用产品前检查工程说明书。
- 不能将没包装材料覆盖的 LCD 进行堆积重叠。
- LCD 含有液晶, 请按当地规定制度处理。
- 不要直接用手触摸 TCP (驱动 IC)、PWB 板。
- 不要触摸玻璃 (偏光片) 表面。

2.0 概括

2.1. 抽样方法

除非有其他书面的协议, 不然抽样检查标准按下面的抽样标准执行:

2.1.1. Lot 大小: 每个型号 1 个托盘;

2.1.2. 抽样类型: 随机抽样

2.1.3. 检查等级: II

2.1.4. 抽样表: MIL-STD-105E

主要不良: AQL=0.65

次要不良: AQL=1.5

2.2. 检查环境

2.2.1. 检查环境条件:

a. 室内温度: $23 \pm 2^{\circ}\text{C}$;

b. 湿度: $60 \pm 10\%$ RH;

c. 外部环境光照: 300~700LUX (功能测试为150~250LUX);

2.2.2. 检查距离

Panel和检查者眼睛之间的距离: 30CM~50CM;

2.2.3. 检查角度

ADS产品: 面向Panel, 所有方向 45° 角内 (与垂直线) (参照产品视角);

TN产品: 面向Panel, 所有方向 10° 角内 (与垂直线) (参照产品视角);

2.2.4. 检查区域:

显示区域(Active区域);

2.3. 主要不良定义

2.3.1. 黑/白点

显示区域显示时在L0/L127/L255画面显示为黑色/白色的点;

2.3.2. 亮/暗线

显示区域显示时在R/G/B画面下可见的明亮/暗色的线, 纵向的、横向的、或者是交叉的;

2.3.3. 亮点(Bright Dot)

显示区域显示时在R/G/B画面下可见的明亮的点 (sub-pixels);

2.3.4. 暗点(Dark Dot)

显示区域显示时在R/G/B画面下可见的暗色的点 (sub-pixels);

2.3.5. Mura

显示区域显示时在L0/L127/L255画面可见的发亮程度不均一的现象区域;

2.3.6. 视觉检查

在通电状态下对产品进行检查;

2.3.7. 外观检查

在未通电状态下对产品进行外部检查;

3.0 检查基准

3.1. 视觉检查基准

单元尺寸: mm

Items	Details	Inspection Criteria		Type	
		A Area	B/C Area		
Visual (Function) Inspection	Pixel Defects	亮点 (W,R,G,B)	N≤0	Ignore	Minor
		暗点	N≤4		
		连续暗点	N≤0		
	Foreign Material /Dent/ Bubble/ Spots//Extraneous Substances	点状	D < 0.15, Ignore ; 0.15 < D ≤ 0.35, N ≤ 3 ; D > 0.35, N = 0	Ignore	Minor
		线状	L ≤ 1mm, W ≤ 0.05mm, N ≤ 3; W > 0.05mm, N ≤ 0	Ignore	Minor
	Scratch	线状	W < 0.05mm, Ignore ; 0.5mm ≤ L ≤ 3mm, W ≤ 0.1mm, N ≤ 3 ; W > 0.1mm, N ≤ 0	Ignore	Minor
	Mura		5%ND 不可见, 检查条件: 环境 照度 80±20Lux; 显示画面 全黑 场	Ignore	Minor
	Total Minor defect		N ≤ 8		
	Abnormal Display		Not Allowed	Ignore	Major
	Line Defect		Not Allowed	Ignore	Major

注意: 所有不良的的测定都基于 Panel 上有偏光片

※ 备注 1) D = 直径, L = 长度, W = 宽度, N = 数量

※ 备注 2) 区域定义 A Area: 显示区 B/C Area: 非显示区

$$D = (a + b) / 2$$

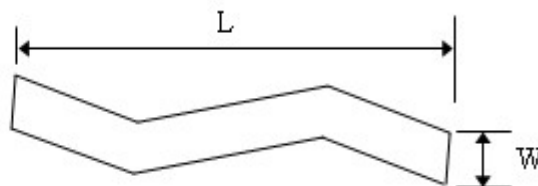

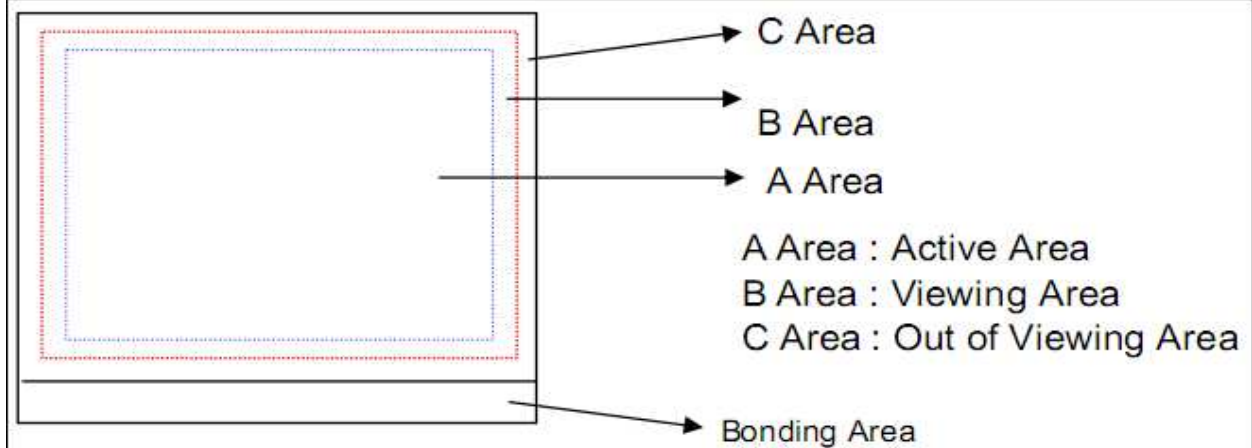

※Note 3) 针对 pixel 的亮点不良, 背光正常点亮的条件下, 大于 $1/2$ sub-pixel 的点为亮点不可有; 小于 $1/2$ sub-pixel 不多于 3 个。

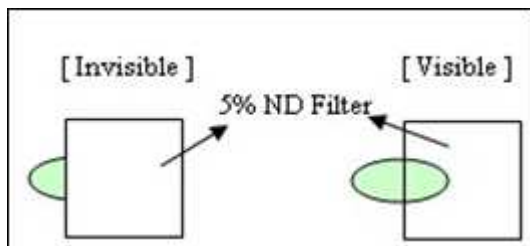

"No dot defect"
(=ignored)

"1 dot defect"
(=counted)

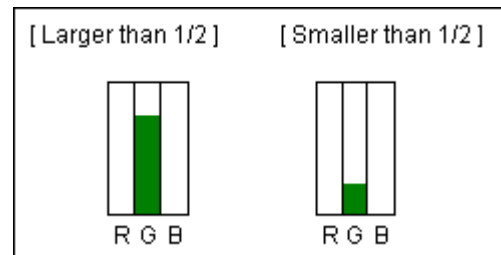

"1 dot defect"
(=counted)

" No dot defect "
(= Not counted)

※Note 4) 连续 Pixel 亮点/暗点类型

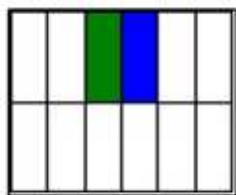

Type 1

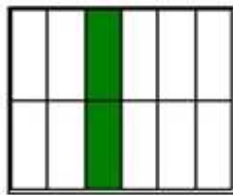



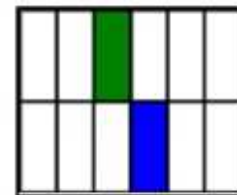



Type 2

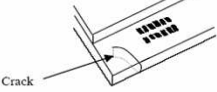

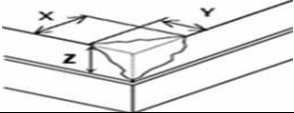
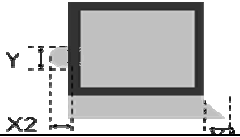
Type 3

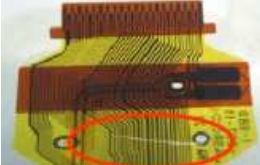
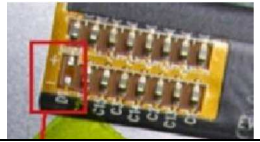
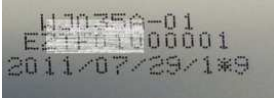
3.2. 外观检查基准

不良位置	Items	Criterion for Defects		Type	适用范围
All	Stain		可擦拭 OK		All
PNL 相关	Crack		不允许	Major	出货状态为 Single Cell/FOG /MDL 产品适用
	Side Chipping		不影响功能和组装	Minor	
	Corner Chipping		不影响功能和组装	Minor	
	Burr		不影响功能和组装	Minor	
	划伤/凹点		贴 POL 之后, 参点状/线状 异物 (划伤) 基准进行判定	Minor	
FPC/PCB 相关	短路/断路		不允许	Major	出货状态为 FOG/MDL 产品适 用
	元器件		元器件缺失不允许	Minor	
Backlight 相关	喷码		关键信息可识别 OK	Minor	出货状态为 MDL 产 品适用
	划伤		Limit Sample	Minor	
	污渍		可擦拭 OK	Minor	

BOE**BOE**京东方科技集团股份有限公司
BOE Technology Group Co., Ltd.

页码: - 10/ 9-

版本 : Rev.1

文件名称

Incoming Inspection Spec For Customer

生效日期 : 2020.5.11

B : BOE客户质量服务流程

为了提供给客户更好的服务，BOE应该提供如下的售后产品质量服务过程：

- 根据P/O，BOE将产品运送到客户指定地点。
- 客户要对来料产品做IQC检查。
- 检查基准由BOE提供，并由客户确认通过，检查手法和不良按双方达成的基准协议确认。
- 为了保证和客户端及时的产品质量沟通和有效的服务，客户端QA部门每周向BOE CS部门提供周别质量报告。
- 客户使用BOE产品要遵守说明书，对于违反说明书的使用BOE不负责。
- 双方在处理产品质量问题时要遵循友好合作策略，对于责任方归属不明确时，双方要谈判解决。

质保期失效

在下列情况中，质保期将会失效：

- a. 质保时间超期；
- b. LCM在没有供应商的允许下交由第三方修复；
- c. LCM在没有供应商的允许下，被客户或是客户的代表方拆开或是维修时。