

### SPECIFICATIONS

<b>CUSTOMER</b>	:	<b>PTC</b>
<b>SAMPLE CODE</b>	:	<b>SH480272T009-IBC03</b>
<b>MASS PRODUCTION CODE</b>	:	<b>PH480272T009-IBC03</b>
<b>SAMPLE VERSION</b>	:	<b>01</b>
<b>SPECIFICATIONS EDITION</b>	:	<b>003</b>
<b>DRAWING NO. (Ver.)</b>	:	<b>JLMD- PH480272T009-IBC03_002</b>
<b>PACKAGING NO. (Ver.)</b>	:	<b>JPKG- PH480272T009-IBC03_002</b>

**Customer Approved**

---

Date:

POWERTIP  
**2016.12.22**  
JS RD APPROVED

Approved	Checked	Designer
閔偉	劉進	徐明菲

- Preliminary specification for design input
- Specification for sample approval

### POWERTIP TECH. CORP.

<b>Headquarters:</b> No.8, 6 <sup>th</sup> Road, Taichung Industrial Park, Taichung, Taiwan 台中市 407 工業區六路 8 號	TEL: 886-4-2355-8168 FAX: 886-4-2355-8166	E-mail: <a href="mailto:sales@powertip.com.tw">sales@powertip.com.tw</a> <a href="http://www.powertip.com.tw">Http://www.powertip.com.tw</a>
--	--	---



## Contents

### 1. SPECIFICATIONS

- 1.1 Features
- 1.2 Mechanical Specifications
- 1.3 Absolute Maximum Ratings
- 1.4 DC Electrical Characteristics
- 1.5 Optical Characteristics
- 1.6 Backlight Characteristics
- 1.7 Touch Panel Characteristics

### 2. MODULE STRUCTURE

- 2.1 Counter Drawing
- 2.2 Interface Pin Description
- 2.3 Timing Characteristics

### 3. QUALITY ASSURANCE SYSTEM

- 3.1 Quality Assurance Flow Chart
- 3.2 Inspection Specification

### 4. RELIABILITY TEST

- 4.1 Reliability Test Condition

### 5. PRECAUTION RELATING PRODUCT HANDLING

- 5.1 Safety
- 5.2 Handling
- 5.3 Storage
- 5.4 Terms of Warranty

- Appendix:
- 1. LCM Drawing
  - 2. LCM Packaging

Note: For detailed information please refer to IC data sheet: ILITEK--- ILI6480B

## 1.1 Features

Item	Standard Value
Display Type	480 * 3 (RGB) * 272 Dots
LCD Type	Normally white TN , Transmissive Type
Screen size(inch)	4.3"(Diagonal)
Viewing Direction	6 O'clock
Color configuration	R,G, B vertical stripe
Display Interface	Digital 24-bits RGB
Driver IC	ILI6480B
ROHS	THIS PRODUCT CONFORMS THE ROHS OF PTC Detail information please refer website : <a href="http://www.powertip.com.tw/news.php?area_id_view=1085560481/">http://www.powertip.com.tw/news.php?area_id_view=1085560481/</a>

## 1.2 Mechanical Specifications

Item	Standard Value	Unit
Outline Dimension	113.2(W) x 73.2 (L) x 5.0(H)	mm

### LCD panel

Item	Standard Value	Unit
Active Area	95.04 (W) * 53.856 (L)	mm
Pixel Size	0.198 (W) * 0.198 (H)	mm

### Touch panel

Item	Standard Value	Unit
View Area	96.2 (W) * 55.0 (L)	mm

Note : For detailed information please refer to LCM drawing

### 1.3 Absolute Maximum Ratings

#### Module

Item	Symbol	Condition	Min.	Max.	Unit
System Power Supply Voltage	$V_{DD}$	GND=0	-0.5	+5.0	V
Operating Temperature	$T_{OP}$	-	-20	+70	°C
Storage Temperature	$T_{ST}$	-	-30	+80	°C
Storage Humidity	$H_b$	$T_a \leq 60\text{ °C}$	10	90	%RH

### 1.4 DC Electrical Characteristics

#### Module

GND = 0V,  $T_a = 25\text{ °C}$

Item	Symbol	Condition	Min.	Typ.	Max.	Unit
Power supply	$V_{DD}$	-	3.0	3.3	3.6	V
	$V_{GH}$	-	-	15	-	V
	$V_{GL}$	-	-	-10	-	V
“H” Input Voltage	$V_{IH}$	-	$0.7 \cdot V_{DD}$	-	$V_{DD}$	V
“L” Input Voltage	$V_{IL}$	-	GND	-	$0.3 \cdot GND$	V
“H” Output Voltage	$V_{OH}$	-	$V_{DD}-0.4$	-	$V_{DD}$	V
“L” Output Voltage	$V_{OL}$	-	GND	-	$GND+0.4$	V
Supply Current	$I_{DD}$	$V_{DD}=3.3V$	-	18	30	mA

## 1.5 Optical Characteristics

### TFT LCD Panel

$V_{DD} = 3.3V, T_a = 25^\circ C$

Item	Symbol	Condition	Min.	Typ.	Max.	unit	
Response time	Tr + Tf	-	-	30	45	ms	Note2
Viewing angle	Top	$\theta+$	-	60	-	Deg.	Note4
	Bottom	$\theta-$	-	60	-		
	Left	$\theta L$	-	60	-		
	Right	$\theta R$	-	60	-		
Contrast ratio	CR		500	600	-	-	-
Color of CIE Coordinate	White	X	0.26	0.31	0.36	-	Note1
		Y	0.28	0.33	0.38		
	Red	X	0.52	0.57	0.62		
		Y	0.28	0.33	0.38		
	Green	X	0.29	0.34	0.39		
		Y	0.56	0.61	0.66		
	Blue	X	0.10	0.15	0.20		
		Y	0.03	0.08	0.13		
Average Brightness (With LCD&TP)*1	IV	IF= 20 mA	260	360	-	cd/m <sup>2</sup>	Note1
Uniformity	$\Delta B$	IF= 20 mA	70	-	-	%	Note1

Note1:

1 :  $\Delta B = B(\min) / B(\max) \times 100\%$

2 : Measurement Condition for Optical Characteristics:

a : Environment:  $25^\circ C \pm 5^\circ C$  /  $60 \pm 20\% R.H$  , no wind , dark room below 10 Lux at typical lamp current and typical operating frequency.

b : Measurement Distance:  $500 \pm 50$  mm , ( $\theta = 0^\circ$ )

c : Equipment: TOPCON BM-7 fast , (field  $1^\circ$ ) , after 10 minutes operation.

d : The uncertainty of the C.I.E coordinate measurement  $\pm 0.01$  , Average Brightness  $\pm 4\%$

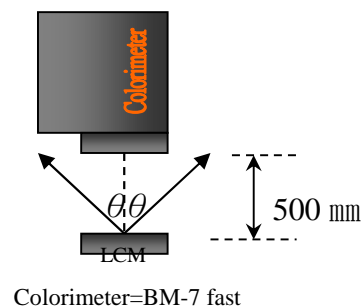
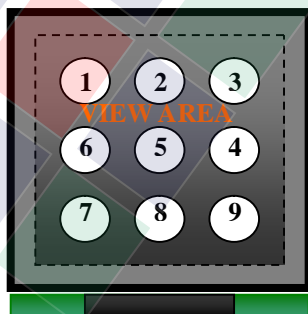

Note2: Definition of response time:

The output signals of photo detector are measured when the input signals are changed from “black” to “white”(falling time) and from “white” to “black”(rising time), respectively. The response time is defined as the time interval between the 10% and 90% of Amplitudes.

Refer to figure as below:

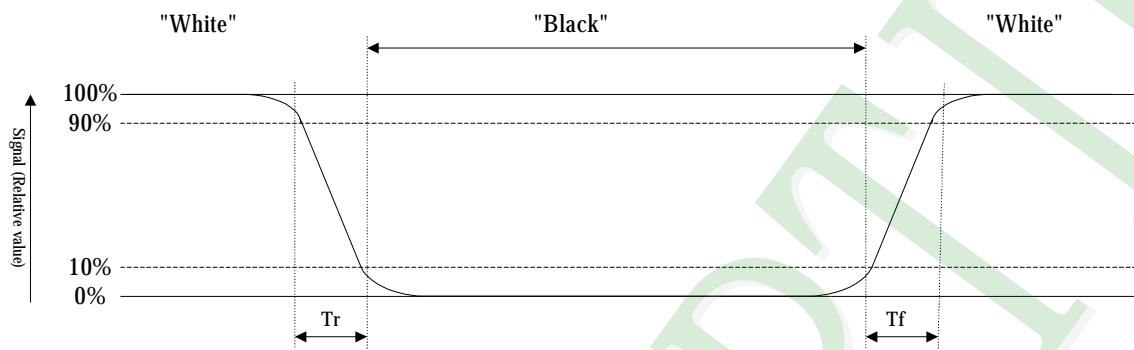

Note3: Definition of contrast ratio:

Contrast ratio is calculated with the following formula

$$\text{Contrast ratio (CR)} = \frac{\text{Photo detector output when LCD is at "White" state}}{\text{Photo detector output when LCD is at "Black" state}}$$

Note4: Definition of viewing angle:

Refer to figure as below:

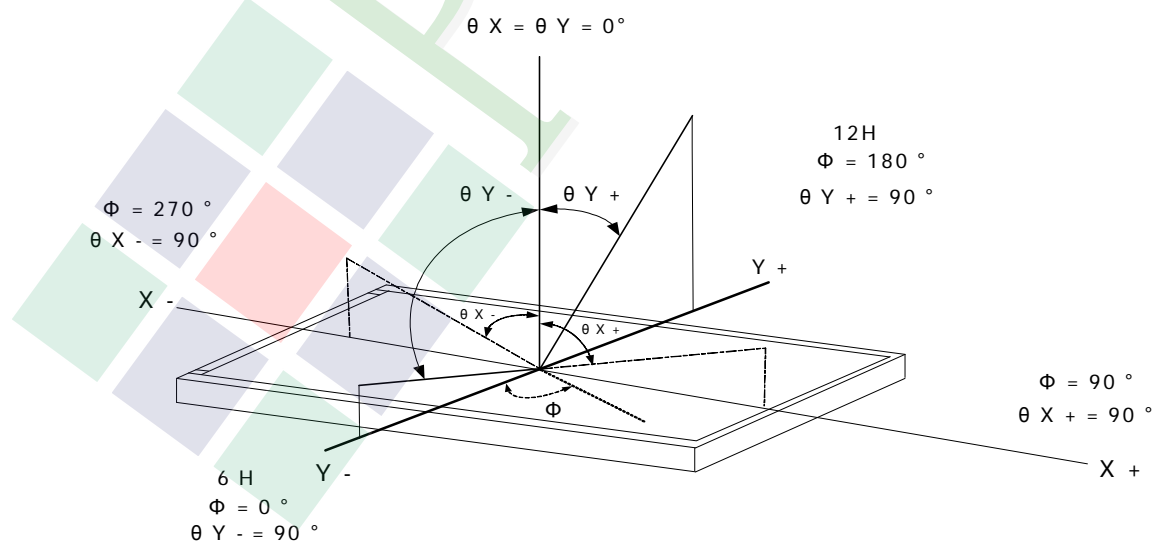

## 1.6 Backlight Characteristics

### Maximum Ratings

Item	Symbol	Conditions	Min.	Max.	Unit
LED Forward Current (Each LED)	IF	Ta =25°C	-	30	mA
LED Reverse Voltage (Each LED)	VR	Ta =25°C	-	5.0	V
Power Dissipation	PD	Ta =25°C	-	90*7	mW

### Electrical / Optical Characteristics

Item	Symbol	Conditions	Min.	Typ.	Max.	Unit
Forward Voltage	VF	IF=20mA	18.2	22.8	24.5	V
Average Brightness (Without LCD )	IV		6000	7200	-	cd/m <sup>2</sup>
CIE Color Coordinate (Without LCD )	X		0.26	0.30	0.33	-
	Y		0.26	0.30	0.33	
LED life time*1	T		-	20,000	-	Hr
Color	White					

### Internal Circuit Diagram



### Other Description

Item	Conditions	Description
Life Time	Ta =25°C IF= 20mA	20000 hrs



## 1.7 Touch Panel Characteristics

### 1.7.1 Product type

- Cover Glass + ITO Film
- Cover Glass + ITO Glass
- Cover Glass + ITO Film+ ITO Film
- Cover Glass + ITO Film(Double-edged ITO)
- Cover Glass + ITO Glass(Double-edged ITO)
- One Glass Solution

### 1.7.2 Material Specifications

Item	Material used	Remark
Circuit	ITO Glass	T=0.7mm

### 1.7.3 Mechanical Specifications

Item	Specification	Remark
Outline Dimension	113.2 × 73.2	mm
Windows	96.2 × 55.0	mm
FPC length	33.0	mm
Product Thickness	0.8 [exclude Foam rubber ,bottem rubber]	mm

Note : For detailed information please refer to CTP drawing

### 1.7.4 Mechanical characteristics

Item	Specification	Remark
Input Mode	Human's Finger	-
Hardness	≥ 6H	by JIS K5400
Precision	+/-1mm@10mm	-
Support Operation	5 Points	-
Number of channels	16 * 10	-
Output Interface	I2C	-
Driver IC	ST1633i	-

### 1.7.5 Electrical characteristics

Item	symbol	Min	Type	Max	Unit	Remark
Supply Voltage	V <sub>DD</sub>	2.8	3.3	3.6	V	-
Supply Current	I <sub>DD</sub>	-	-	-	mA	-

### 1.7.6 Optical characteristics

Item	Specification	Remark
Transparency	≥ 85%	-
Haze	≤ 3%	-

### 1.7.7 Interface Pin Description

Pin No.	Symbol	Function	Remark
1	GND	Ground.	Power
2	SDA	I2C Data.	I / O
3	SCL	I2C Clock.	I / O
4	TPVDD	Power.	Power
5	INT	Indicate coordinate data ready	I / O
6	XRES	RESET.	I

## 2. MODULE STRUCTURE

### 2.1 Counter Drawing

#### 2.1.1 LCM Mechanical Diagram

\* See Appendix

#### 2.1.2 Block Diagram

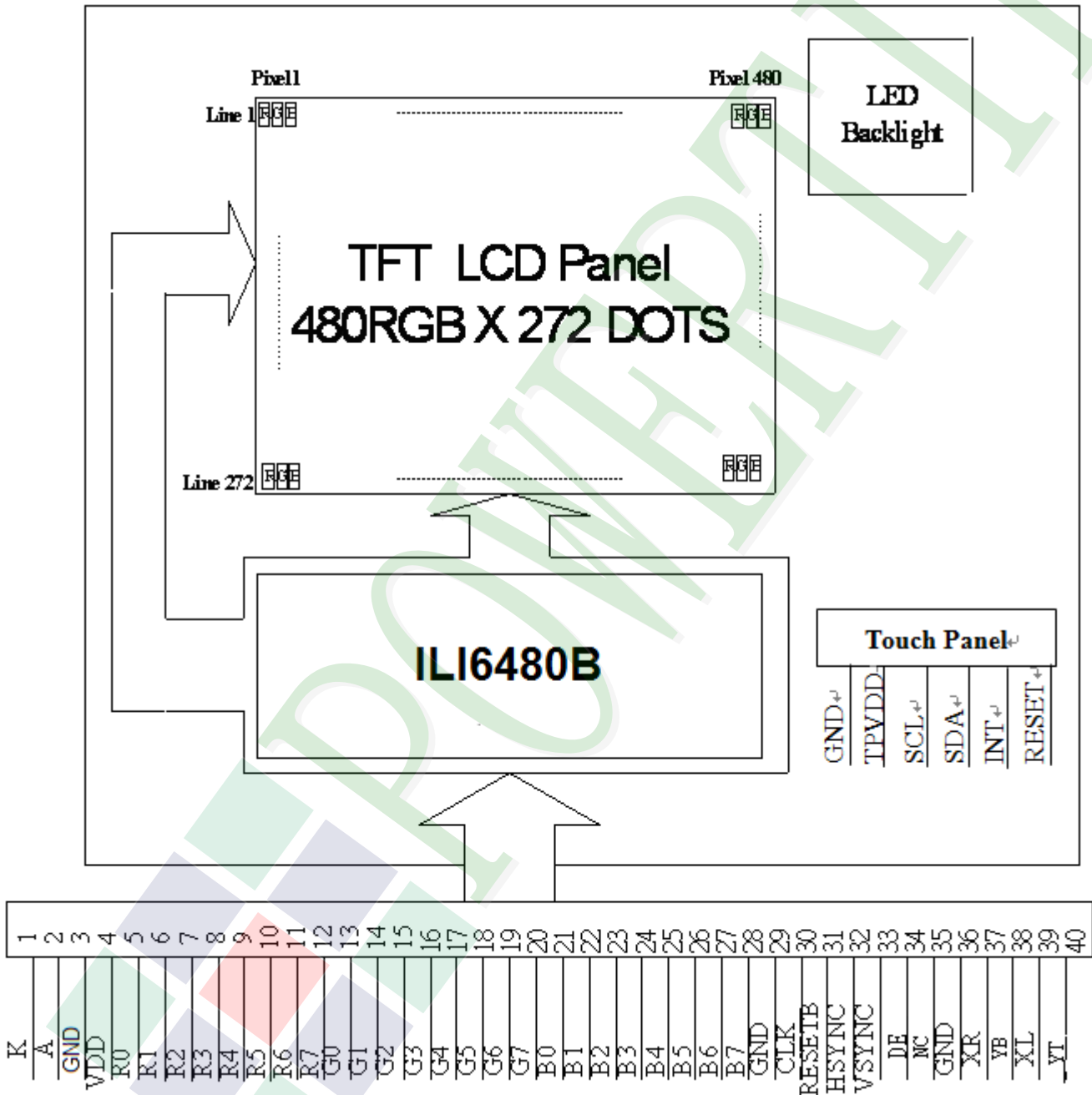

## 2.2 Interface Pin Description

Pin No.	Symbol	Function
1	K	Power supply for LED Backlight cathode input
2	A	Power supply for LED Backlight anode input
3	GND	Ground
4	VDD	Digital power
5	R0	Red data bit 0
6	R1	Red data bit 1
7	R2	Red data bit 2
8	R3	Red data bit 3
9	R4	Red data bit 4
10	R5	Red data bit 5
11	R6	Red data bit 6
12	R7	Red data bit 7
13	G0	Green data bit 0
14	G1	Green data bit 1
15	G2	Green data bit 2
16	G3	Green data bit 3
17	G4	Green data bit 4
18	G5	Green data bit 5
19	G6	Green data bit 6
20	G7	Green data bit 7

Pin No.	Symbol	Function
21	B0	Blue data bit 0
22	B1	Blue data bit 1
23	B2	Blue data bit 2
24	B3	Blue data bit 3
25	B4	Blue data bit 4
26	B5	Blue data bit 5
27	B6	Blue data bit 6
28	B7	Blue data bit 7
29	GND	Ground
30	CLK	Dot data clock
31	DISP	Display control / standby mode selection "High" : Normal display
32	HSYNC	Horizontal sync input
33	VSYNC	Vertical sync input
34	DE	Data input enable. Active High to enable the data input
35	N.C	Not Connect.
36	GND	Ground
37	XR	Not Connect.
38	YB	Not Connect.
39	XL	Not Connect.
40	YT	Not Connect.

## 2.3 Timing Characteristics

### 2.3.1 Clock and Data Input Waveforms

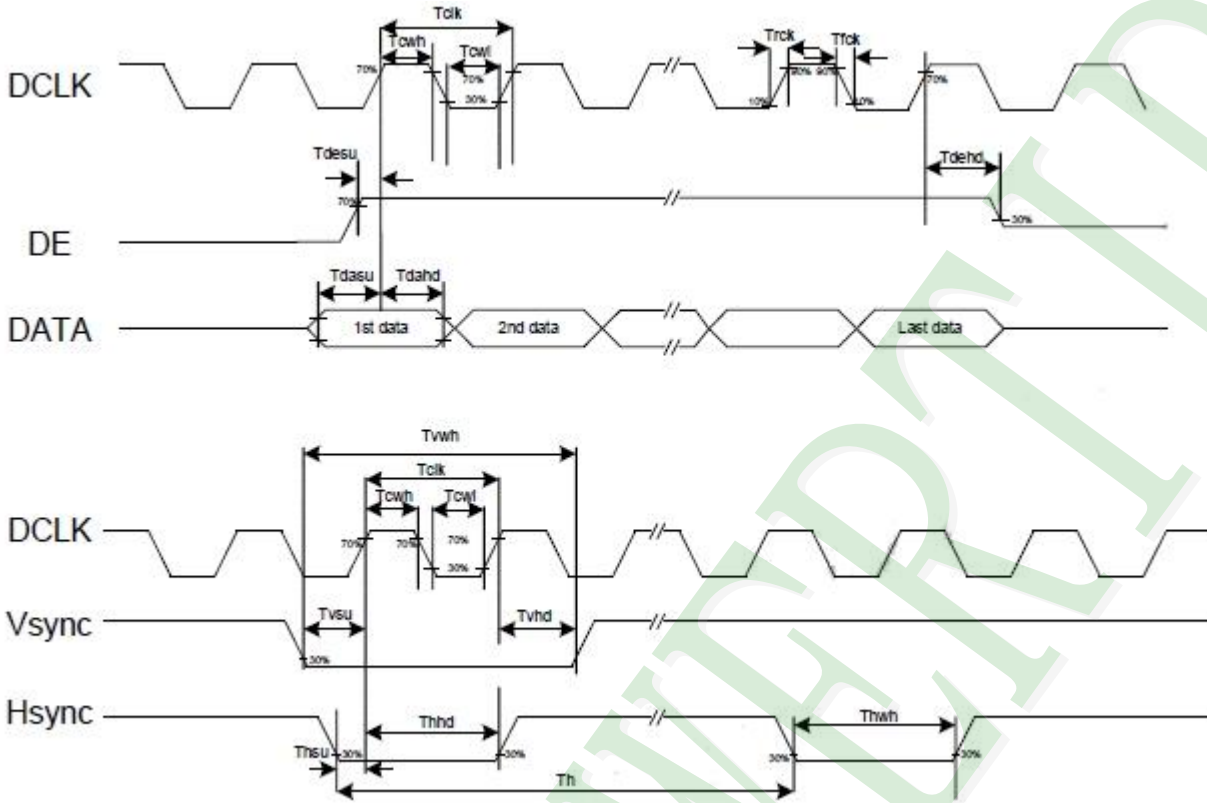

Parameters	Symbol	Min.	Typ.	Max.	Unit	Conditions
<b>System operation timing</b>						
VDD power source slew time	TPOR	-	-	20	ms	From 0V to 99% VDD
GRB pulse width	tRSTW	10	50	-	us	R=10Kohm, C=1uF
<b>Input Output timing</b>						
DCLK clock time	Tclk	33.3	-	-	ns	DCLK=30MHz
DCLK clock low period	Tcwl	40	-	60	%	
DCLK clock high period	Tcwh	40	-	60	%	
Clock rising time	Trck	9	-	-	ns	
Clock falling time	Tfck	9	-	-	ns	
HSD width	Thwh	1	-	-	DCLK	
HSD period time	Th	55	60	65	us	
HSD setup time	Thsu	12	-	-	ns	
HSD hold time	Thhd	12	-	-	ns	
VSD width	Twvh	1	-	-	Th	
VSD setup time	Tvsu	12	-	-	ns	
VSD hold time	Tvhd	12	-	-	ns	
Data setup time	Tdasu	12	-	-	ns	
Data hold time	Tdahd	12	-	-	ns	
DE setup time	Tdesu	12	-	-	ns	
DE hold time	Tdehd	12	-	-	ns	
Source output setting time	Tsst	-	-	TBD	us	10% to 90% CL=60pF, RL=2Kohm
Gate output setting time	Tgst	-	-	1200	ns	10% to 90%, CL=60pF
VCOM output setting time	Tcst	-	-	TBD	us	10% to 90%, CL=40nF, RL=50ohm
Time from VSD to 1st line data input	Tvs	3	8	31	Th	HV mode By HDL[4:0] setting



### 2.3.2 Data Input Format

Vertical input timing

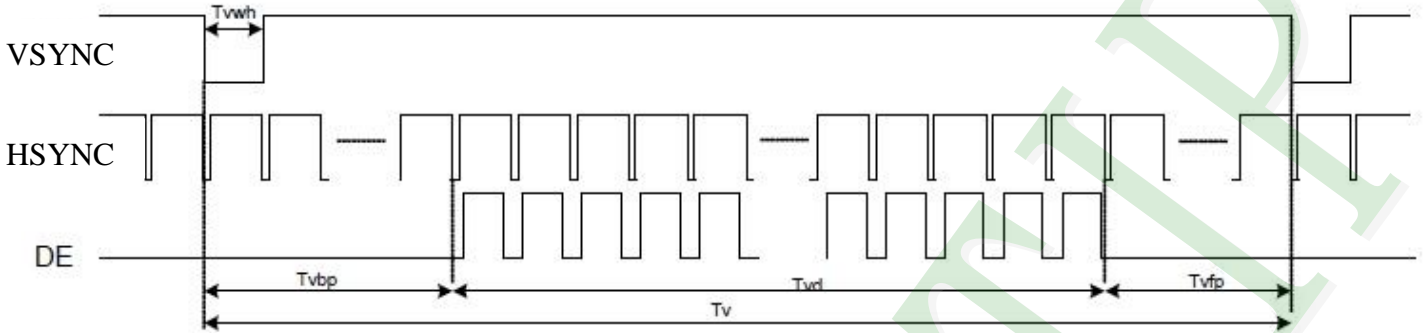

Parallel RGB Mode Data format

(HV Mode)

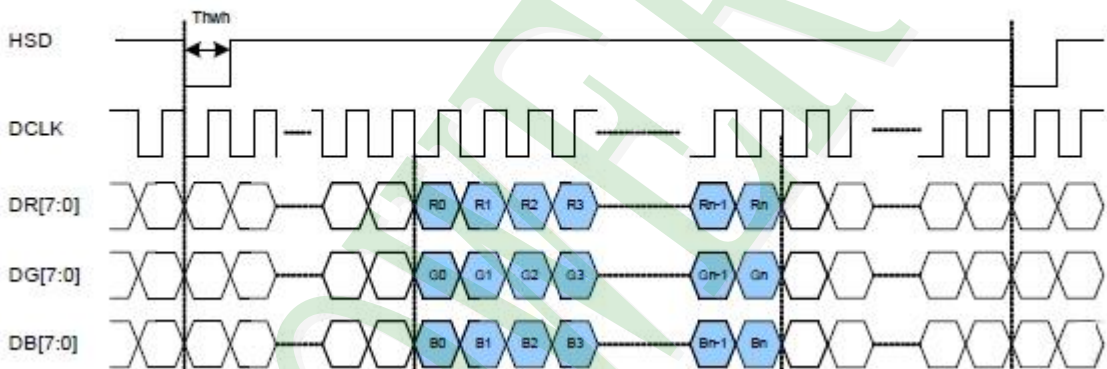

(DE Mode)

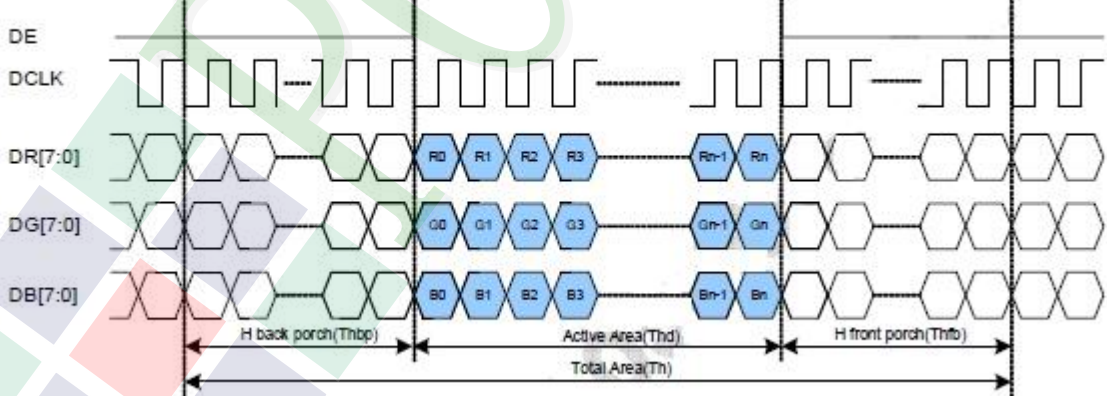



**Parallel RGB input timing table**

Parameters	Symbol	Value			Unit
		Min.	Typ.	Max.	
DCLK frequency	Fclk	5	9	12	MHz
VSYNC period time	Tv	277	288	400	H
VSYNC display area	Tvd	272			H
VSYNC back porch	Tvb	3	8	31	H
VSYNC front porch	Tvfp	2	8	97	H
HSYNC period time	Th	520	525	800	DCLK
HSYNC display area	Thd	480			DCLK
HSYNC back porch	Thbp	36	40	255	DCLK
HSYNC front porch	Thfp	4	5	65	DCLK

### 3. QUALITY ASSURANCE SYSTEM

#### 3.1 Quality Assurance Flow Chart

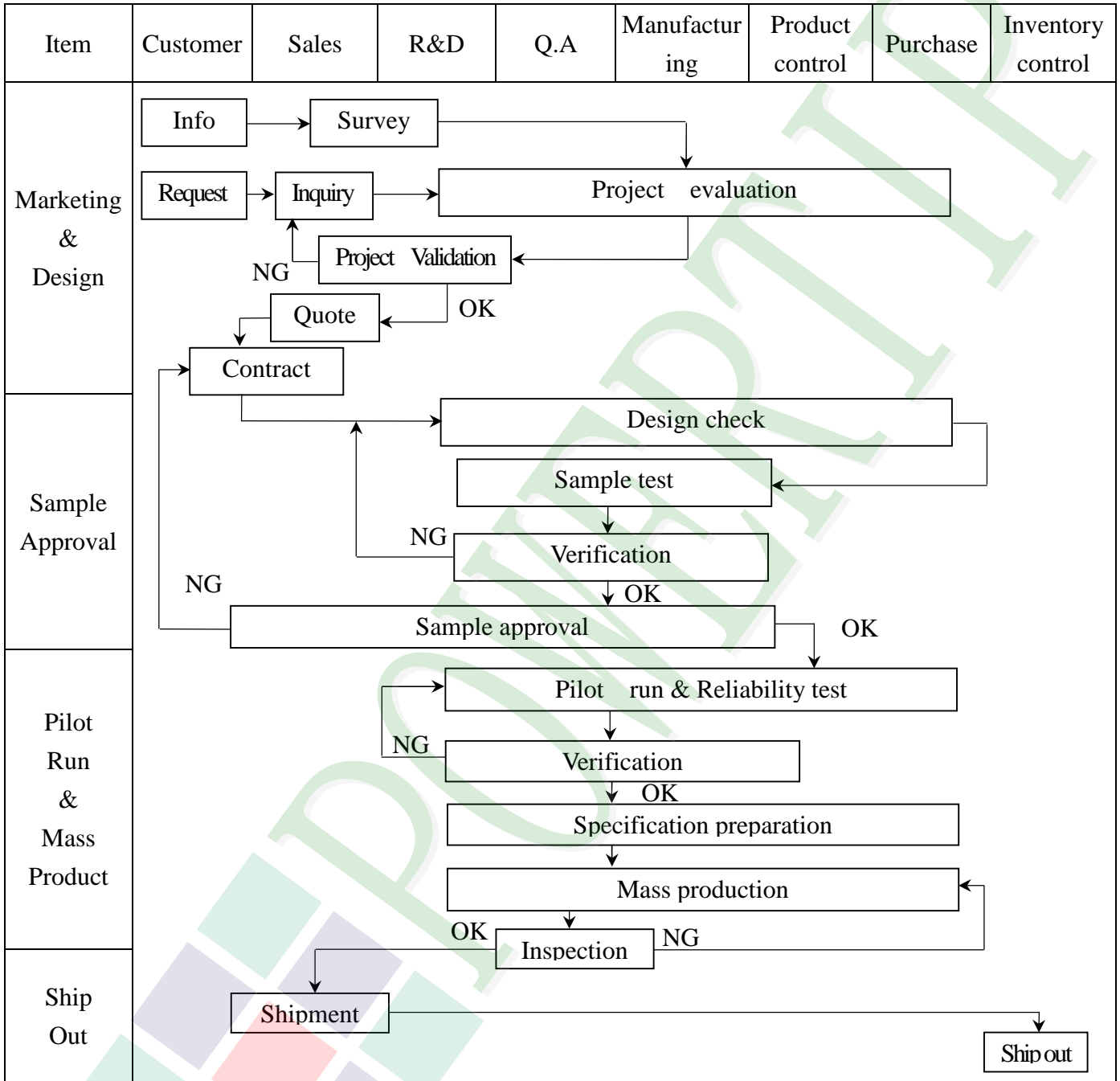

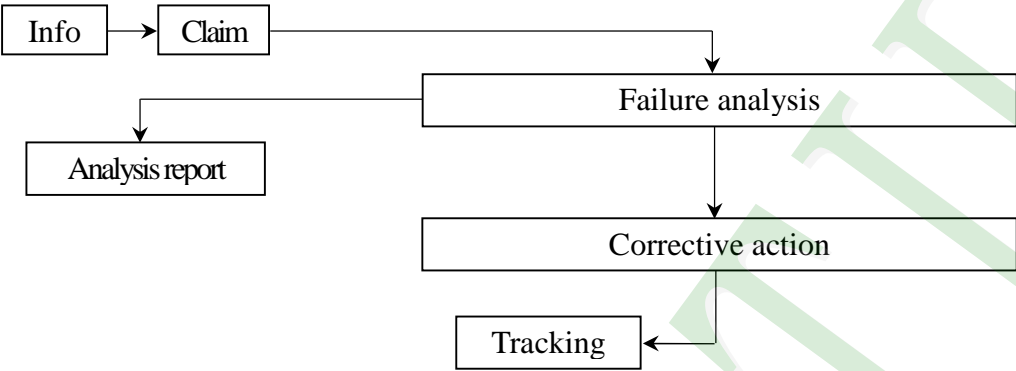
Item	Customer	Sales	R&D	Q.A	Manufacturing	Product control	Purchase	Inventory control
Sales Service	 <pre> graph TD     Info[Info] --&gt; Claim[Claim]     Claim --&gt; Failure[Failure analysis]     Failure --&gt; Report[Analysis report]     Failure --&gt; Action[Corrective action]     Action --&gt; Tracking[Tracking]           </pre>							
Q.A Activity	1. ISO 9001 Maintenance Activities 3. Equipment calibration 5. Standardization Management				2. Process improvement proposal 4. Education And Training Activities			

### 3.2. Inspection Specification

- ◆Scope : The document shall be applied to TFT-LCD Module for 3.5" ~10" (Ver.B01).
- ◆Inspection Standard : MIL-STD-105E Table Normal Inspection Single Sampling Level II.
- ◆Equipment : Gauge 、 MIL-STD 、 Powertip Tester 、 Sample
- ◆Defect Level : Major Defect AQL : 0.4 ; Minor Defect AQL : 1.5
- ◆OUT Going Defect Level : Sampling.
- ◆Standard of the product appearance test :

a. Manner of appearance test :

- (1). The test best be under 20W×2 fluorescent light , and distance of view must be at 30 cm.
- (2). The test direction is base on about around 45° of vertical line.

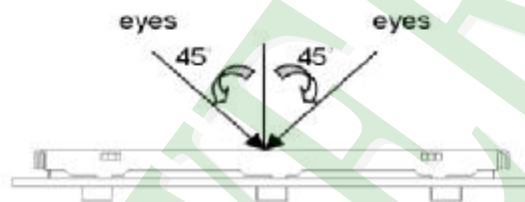

(3). Definition of area.

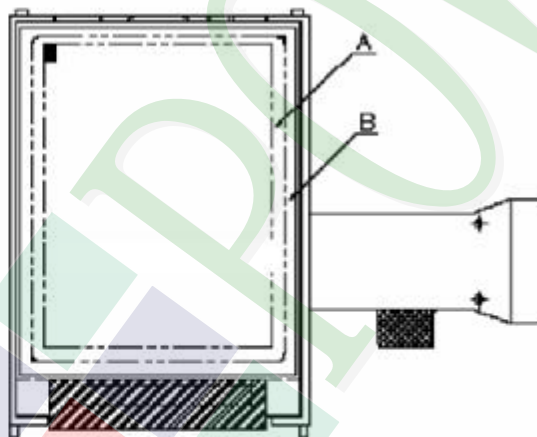

*A* area : viewing area

*B* area : Outside of viewing area

(4). Standard of inspection : (Unit : mm)

◆ Specification For TFT-LCD Module 3.5" ~ 10" :

(Ver.B01)

NO	Item	Criterion	Level										
01	Product condition	1. 1 The part number is inconsistent with work order of production.	Major										
		1. 2 Mixed product types.	Major										
		1. 3 Assembled in inverse direction.	Major										
02	Quantity	2. 1 The quantity is inconsistent with work order of production.	Major										
03	Outline dimension	3. 1 Product dimension and structure must conform to structure diagram.	Major										
		4. 1 Missing line character and icon.	Major										
04	Electrical Testing	4. 2 No function or no display.	Major										
		4. 3 Display malfunction.	Major										
		4. 4 LCD viewing angle defect.	Major										
		4. 5 Current consumption exceeds product specifications.	Major										
05	Dot defect (Bright dot , Dark dot) On -display	<table border="1"> <thead> <tr> <th>Item</th> <th>Acceptance (Q'ty)</th> </tr> </thead> <tbody> <tr> <td>Bright Dot</td> <td><math>\leq 4</math></td> </tr> <tr> <td>Dark Dot</td> <td><math>\leq 5</math></td> </tr> <tr> <td>Joint Dot</td> <td><math>\leq 3</math></td> </tr> <tr> <td>Total</td> <td><math>\leq 7</math></td> </tr> </tbody> </table>	Item	Acceptance (Q'ty)	Bright Dot	$\leq 4$	Dark Dot	$\leq 5$	Joint Dot	$\leq 3$	Total	$\leq 7$	Minor
		Item	Acceptance (Q'ty)										
		Bright Dot	$\leq 4$										
		Dark Dot	$\leq 5$										
		Joint Dot	$\leq 3$										
Total	$\leq 7$												
5. 1 Inspection pattern : full white , full black , Red , Green and blue screens.													
5. 2 It is defined as dot defect if defect area $> 1/2$ dot.													
5. 3 The distance between two dot defect $\geq 5$ mm.													

◆ Specification For TFT-LCD Module 3.5" ~10" :

(Ver.B01)

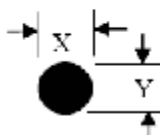
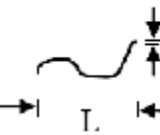
NO	Item	Level																																							
06	<p style="text-align: center;"><b>6.1 Round type ( Non-display or display ) :</b></p> <div style="display: flex; justify-content: space-between;"> <div style="width: 30%;"> <p>Black or white dot , scratch , contamination</p> <p>Round type</p>  <p><math>\Phi = (x + y) / 2</math></p> <p>Line type</p>  </div> <div style="width: 60%;"> <table border="1" style="margin-bottom: 20px;"> <thead> <tr> <th rowspan="2">Dimension (diameter : <math>\Phi</math>)</th> <th colspan="2">Acceptance (Q'ty)</th> </tr> <tr> <th>A area</th> <th>B area</th> </tr> </thead> <tbody> <tr> <td><math>\Phi \leq 0.25</math></td> <td colspan="2">Ignore</td> </tr> <tr> <td><math>0.25 &lt; \Phi \leq 0.50</math></td> <td>5</td> <td rowspan="3">Ignore</td> </tr> <tr> <td><math>\Phi &gt; 0.50</math></td> <td>0</td> </tr> <tr> <td><b>Total</b></td> <td><b>5</b></td> </tr> </tbody> </table> <p style="text-align: center;"><b>6.2 Line type( Non-display or display ) :</b></p> <table border="1"> <thead> <tr> <th rowspan="2">Length (L)</th> <th rowspan="2">Width (W)</th> <th colspan="2">Acceptance (Q'ty)</th> </tr> <tr> <th>A area</th> <th>B area</th> </tr> </thead> <tbody> <tr> <td>---</td> <td><math>W \leq 0.03</math></td> <td colspan="2">Ignore</td> </tr> <tr> <td><math>L \leq 10.0</math></td> <td><math>0.03 &lt; W \leq 0.05</math></td> <td>4</td> <td rowspan="3">Ignore</td> </tr> <tr> <td><math>L \leq 5.0</math></td> <td><math>0.05 &lt; W \leq 0.10</math></td> <td>2</td> </tr> <tr> <td>---</td> <td><math>W &gt; 0.10</math></td> <td>As round type</td> </tr> <tr> <td><b>Total</b></td> <td></td> <td><b>5</b></td> <td></td> </tr> </tbody> </table> </div> </div>	Dimension (diameter : $\Phi$ )	Acceptance (Q'ty)		A area	B area	$\Phi \leq 0.25$	Ignore		$0.25 < \Phi \leq 0.50$	5	Ignore	$\Phi > 0.50$	0	<b>Total</b>	<b>5</b>	Length (L)	Width (W)	Acceptance (Q'ty)		A area	B area	---	$W \leq 0.03$	Ignore		$L \leq 10.0$	$0.03 < W \leq 0.05$	4	Ignore	$L \leq 5.0$	$0.05 < W \leq 0.10$	2	---	$W > 0.10$	As round type	<b>Total</b>		<b>5</b>		Minor
Dimension (diameter : $\Phi$ )	Acceptance (Q'ty)																																								
	A area	B area																																							
$\Phi \leq 0.25$	Ignore																																								
$0.25 < \Phi \leq 0.50$	5	Ignore																																							
$\Phi > 0.50$	0																																								
<b>Total</b>	<b>5</b>																																								
Length (L)	Width (W)	Acceptance (Q'ty)																																							
		A area	B area																																						
---	$W \leq 0.03$	Ignore																																							
$L \leq 10.0$	$0.03 < W \leq 0.05$	4	Ignore																																						
$L \leq 5.0$	$0.05 < W \leq 0.10$	2																																							
---	$W > 0.10$	As round type																																							
<b>Total</b>		<b>5</b>																																							
07	<p>Polarizer Bubble</p> <table border="1" style="margin-left: auto; margin-right: auto;"> <thead> <tr> <th rowspan="2">Dimension (diameter : <math>\Phi</math>)</th> <th colspan="2">Acceptance (Q'ty)</th> </tr> <tr> <th>A area</th> <th>B area</th> </tr> </thead> <tbody> <tr> <td><math>\Phi \leq 0.25</math></td> <td colspan="2">Ignore</td> </tr> <tr> <td><math>0.25 &lt; \Phi \leq 0.50</math></td> <td>4</td> <td rowspan="3">Ignore</td> </tr> <tr> <td><math>0.50 &lt; \Phi \leq 0.80</math></td> <td>1</td> </tr> <tr> <td><math>\Phi &gt; 0.80</math></td> <td>0</td> </tr> <tr> <td><b>Total</b></td> <td><b>5</b></td> <td></td> </tr> </tbody> </table>	Dimension (diameter : $\Phi$ )	Acceptance (Q'ty)		A area	B area	$\Phi \leq 0.25$	Ignore		$0.25 < \Phi \leq 0.50$	4	Ignore	$0.50 < \Phi \leq 0.80$	1	$\Phi > 0.80$	0	<b>Total</b>	<b>5</b>		Minor																					
Dimension (diameter : $\Phi$ )	Acceptance (Q'ty)																																								
	A area	B area																																							
$\Phi \leq 0.25$	Ignore																																								
$0.25 < \Phi \leq 0.50$	4	Ignore																																							
$0.50 < \Phi \leq 0.80$	1																																								
$\Phi > 0.80$	0																																								
<b>Total</b>	<b>5</b>																																								

**◆Specification For TFT-LCD Module 3.5" ~10" :**

(Ver.B01)

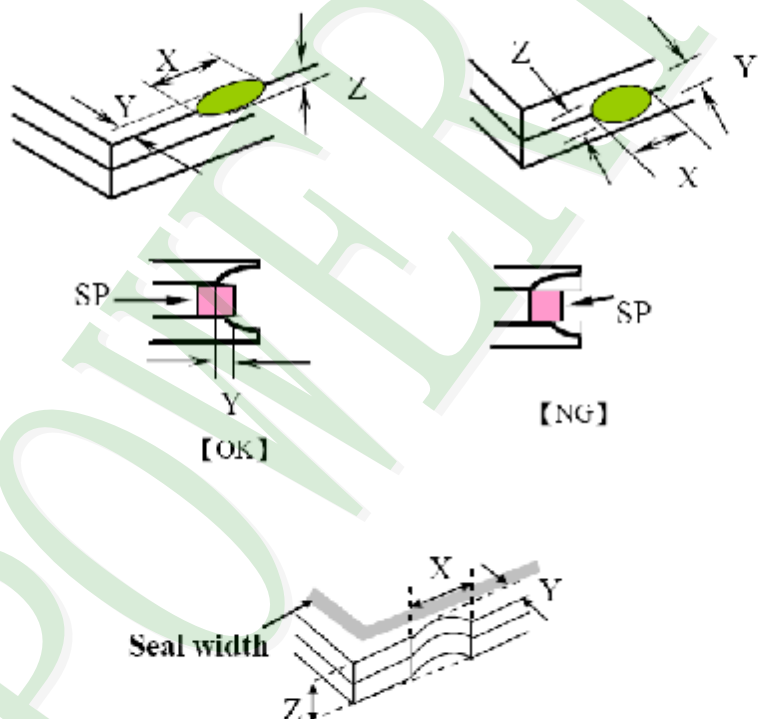
NO	Item	Criterion	Level						
08	The crack of glass	<p><b>Symbols :</b></p> <p><b>X :</b> The length of crack  <b>Z :</b> The thickness of crack  <b>t :</b> The thickness of glass</p> <p><b>Y :</b> The width of crack.  <b>W :</b> terminal length  <b>a :</b> LCD side length</p>	Minor						
		<p>8.1 General glass chip :</p> <p>8.1.1 Chip on panel surface and crack between panels:</p>  <table border="1" data-bbox="542 1568 1340 1859"> <thead> <tr> <th>X</th> <th>Y</th> <th>Z</th> </tr> </thead> <tbody> <tr> <td><math>\leq a</math></td> <td>Crack can't enter viewing area</td> <td><math>\leq 1/2 t</math></td> </tr> <tr> <td><math>\leq a</math></td> <td>Crack can't exceed the half of SP width.</td> <td><math>1/2 t &lt; Z \leq 2 t</math></td> </tr> </tbody> </table>		X	Y	Z	$\leq a$	Crack can't enter viewing area	$\leq 1/2 t$
X	Y	Z							
$\leq a$	Crack can't enter viewing area	$\leq 1/2 t$							
$\leq a$	Crack can't exceed the half of SP width.	$1/2 t < Z \leq 2 t$							



◆ Specification For TFT-LCD Module 3.5" ~10" :

(Ver.B01)

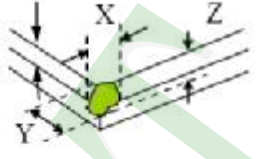
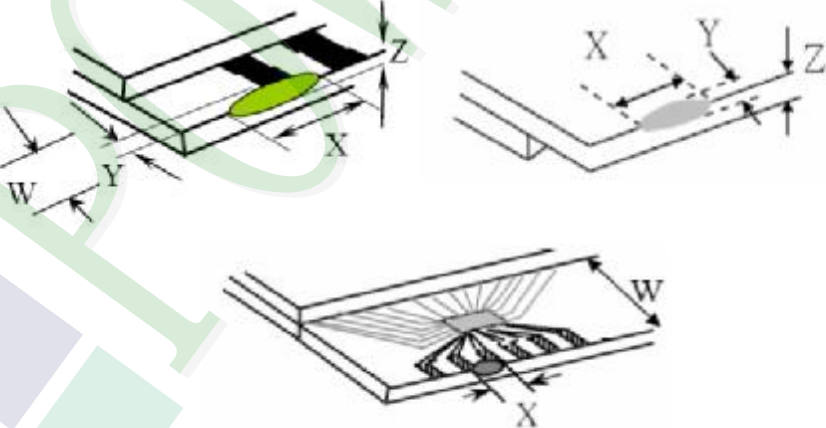
NO	Item	Criterion	Level										
08	The crack of glass	<p><b>Symbols :</b></p> <p><b>X :</b> The length of crack  <b>Z :</b> The thickness of crack  <b>t :</b> The thickness of glass</p> <p><b>Y :</b> The width of crack.  <b>W :</b> terminal length  <b>a :</b> LCD side length</p> <hr/> <p>8.1.2 Corner crack :</p>  <table border="1" data-bbox="523 772 1332 1064"> <thead> <tr> <th>X</th> <th>Y</th> <th>Z</th> </tr> </thead> <tbody> <tr> <td><math>\leq 1/5 a</math></td> <td>Crack can't enter viewing area</td> <td><math>Z \leq 1/2 t</math></td> </tr> <tr> <td><math>\leq 1/5 a</math></td> <td>Crack can't exceed the half of SP width.</td> <td><math>1/2 t &lt; Z \leq 2 t</math></td> </tr> </tbody> </table>	X	Y	Z	$\leq 1/5 a$	Crack can't enter viewing area	$Z \leq 1/2 t$	$\leq 1/5 a$	Crack can't exceed the half of SP width.	$1/2 t < Z \leq 2 t$		
		X	Y	Z									
$\leq 1/5 a$	Crack can't enter viewing area	$Z \leq 1/2 t$											
$\leq 1/5 a$	Crack can't exceed the half of SP width.	$1/2 t < Z \leq 2 t$											
<p>8.2 Protrusion over terminal :</p> <p>8.2.1 Chip on electrode pad :</p>  <table border="1" data-bbox="561 1691 1343 1863"> <thead> <tr> <th></th> <th>X</th> <th>Y</th> <th>Z</th> </tr> </thead> <tbody> <tr> <td>Front</td> <td><math>\leq a</math></td> <td><math>\leq 1/2 W</math></td> <td><math>\leq t</math></td> </tr> <tr> <td>Back</td> <td><math>\leq a</math></td> <td><math>\leq W</math></td> <td><math>\leq 1/2 t</math></td> </tr> </tbody> </table>		X	Y	Z	Front	$\leq a$	$\leq 1/2 W$	$\leq t$	Back	$\leq a$	$\leq W$	$\leq 1/2 t$	Minor
	X	Y	Z										
Front	$\leq a$	$\leq 1/2 W$	$\leq t$										
Back	$\leq a$	$\leq W$	$\leq 1/2 t$										



◆ Specification For TFT-LCD Module 3.5" -10" :

(Ver.B01)

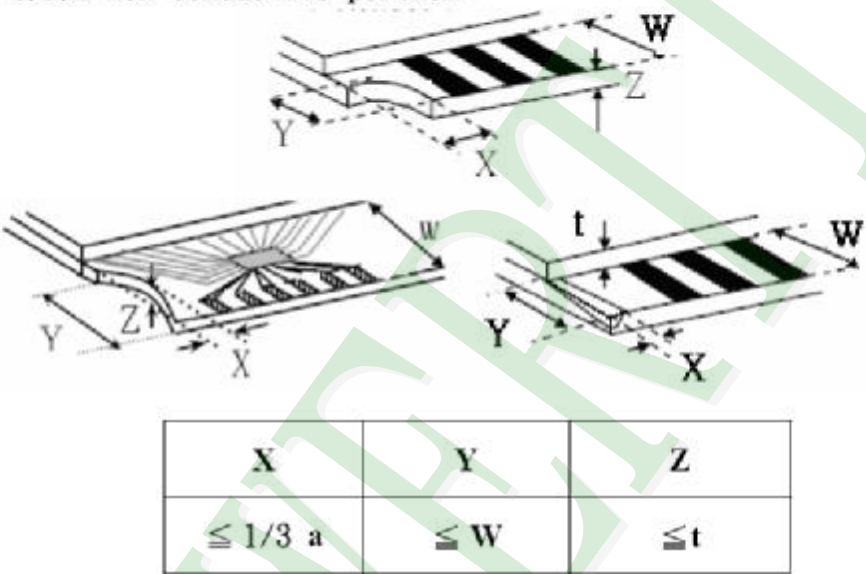
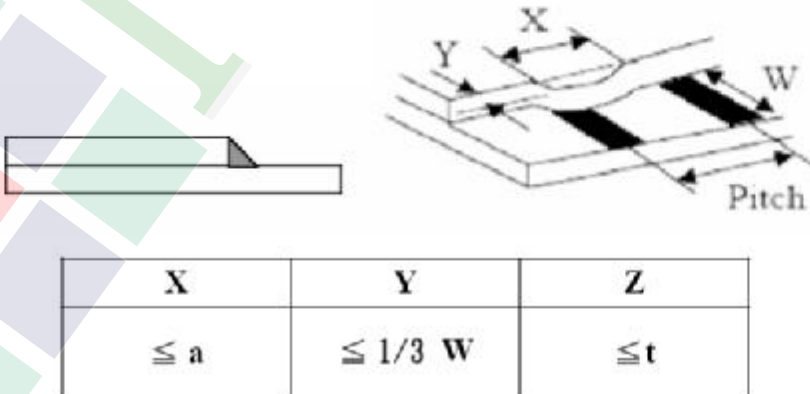
NO	Item	Criterion	Level
08	The crack of glass	<p>Symbols :</p> <p>X : The length of crack                      Y : The width of crack.            Z : The thickness of crack                W : terminal length            t : The thickness of glass                 a : LCD side length</p>	Minor
		<p>8.2.2 Non-conductive portion :</p>  <p>⊙ If the chipped area touches the ITO terminal, over 2/3 of the ITO must remain and be inspected according to electrode terminal specifications.</p> <p>8.2.3 Glass remain :</p> 	

**◆Specification For TFT-LCD Module 3.5" ~10" :**

(Ver.B01)

NO	Item	Criterion	Level
09	Backlight elements	9. 1 Backlight can't work normally.	Major
		9. 2 Backlight doesn't light or color is wrong.	Major
		9. 3 Illumination source flickers when lit.	Major
10	General appearance	10. 1 Pin type 、 quantity 、 dimension must match type in structure diagram.	Major
		10. 2 No short circuits in components on PCB or FPC .	Major
		10. 3 Parts on PCB or FPC must be the same as on the production characteristic chart .There should be no wrong parts , missing parts or excess parts.	Major
		10. 4 Product packaging must the same as specified on packaging specification sheet.	Minor
		10. 5 The folding and pceled off in polarizer are not acceptable.	Minor
		10. 6 The PCB or FPC between B/L assembled distance(PCB or FPC ) is $\leq 1.5$ mm.	Minor



## 5. PRECAUTION RELATING PRODUCT HANDLING

### 5.1 SAFETY

- 5.1.1 If the LCD panel breaks , be careful not to get the liquid crystal to touch your skin.
- 5.1.2 If the liquid crystal touches your skin or clothes , please wash it off immediately by using soap and water.

### 5.2 HANDLING

- 5.2.1 Avoid any strong mechanical shock which can break the glass.
- 5.2.2 Avoid static electricity which can damage the CMOS LSI—When working with the module , be sure to ground your body and any electrical equipment you may be using.
- 5.2.3 Do not remove the panel or frame from the module.
- 5.2.4 The polarizing plate of the display is very fragile. So , please handle it very carefully ,do not touch , push or rub the exposed polarizing with anything harder than an HB pencil lead (glass , tweezers , etc.)
- 5.2.5 Do not wipe the polarizing plate with a dry cloth , as it may easily scratch the surface of plate.
- 5.2.6 Do not touch the display area with bare hands , this will stain the display area.
- 5.2.7 Do not use ketonics solvent & aromatic solvent. Use with a soft cloth soaked with a cleaning naphtha solvent.
- 5.2.8 To control temperature and time of soldering is  $320\pm 10^{\circ}\text{C}$  and 3-5 sec.
- 5.2.9 To avoid liquid (include organic solvent) stained on LCM .

### 5.3 STORAGE

- 5.3.1 Store the panel or module in a dark place where the temperature is  $25^{\circ}\text{C} \pm 5^{\circ}\text{C}$  and the humidity is below 65% RH.
- 5.3.2 Do not place the module near organics solvents or corrosive gases.
- 5.3.3 Do not crush , shake , or jolt the module.

### 5.4 TERMS OF WARRANTY

- 5.4.1 Applicable warrant period  
The period is within thirteen months since the date of shipping out under normal using and storage conditions.
- 5.4.2 Unaccepted responsibility  
This product has been manufactured to your company's specification as a part for use in your company's general electronic products. It is guaranteed to perform according to delivery specifications. For any other use apart from general electronic equipment , we cannot take responsibility if the product is used in nuclear power control equipment , aerospace equipment , fire and security systems or any other applications in which there is a direct risk to human life and where extremely high levels of reliability are required.





Ver.002

Documents NO. JPKG-PH480272T009-IBC03

## LCM包裝規格書

LCM Packaging Specifications  
(For Tray)

Approve	Check	Contact
Ryan	Terry	Air

## 1. 包裝材料規格表 (Packaging Material) : (per carton)

No.	Item	Model	Dimensions (mm)	1Pcs Weight	Quantity	Total Weight
1	成品 (LCM)	PH480272T009-IBC03	113.2X73.2X5.0	0.0668	144	9.6192
2	多層薄膜(1)POF	OTFILM0BA03ABA	19"X350X0.015	—	6	—
3	TRAY 盤 (2)Tray	TY00000000388	352 X 260 X 14.2	0.1	42	4.2
4	內盒(3)Product Box	BX36627063ABBA	383 X 270 X 66	0.182	6	1.092
5	保利龍板(4)Pollyon board	OTPLB00PL08ABA	550 X 393 X 20	0.0284	2	0.0568
6	外紙箱(5)Carton	BX57041027CCBA	570 X 410 X 265	1.0	1	1.0
7						
8						
9						

2. 一整箱總重量 (Total LCD Weight in carton) : 15.97 Kg±10%

3. 單箱數量規格表 (Packaging Specifications and Quantity) :

(1) LCM quantity per box : no per tray	4	x no of tray	6	=	24
(2) Total LCM quantity in carton : quantity per box	24	x no of boxes	6	=	144

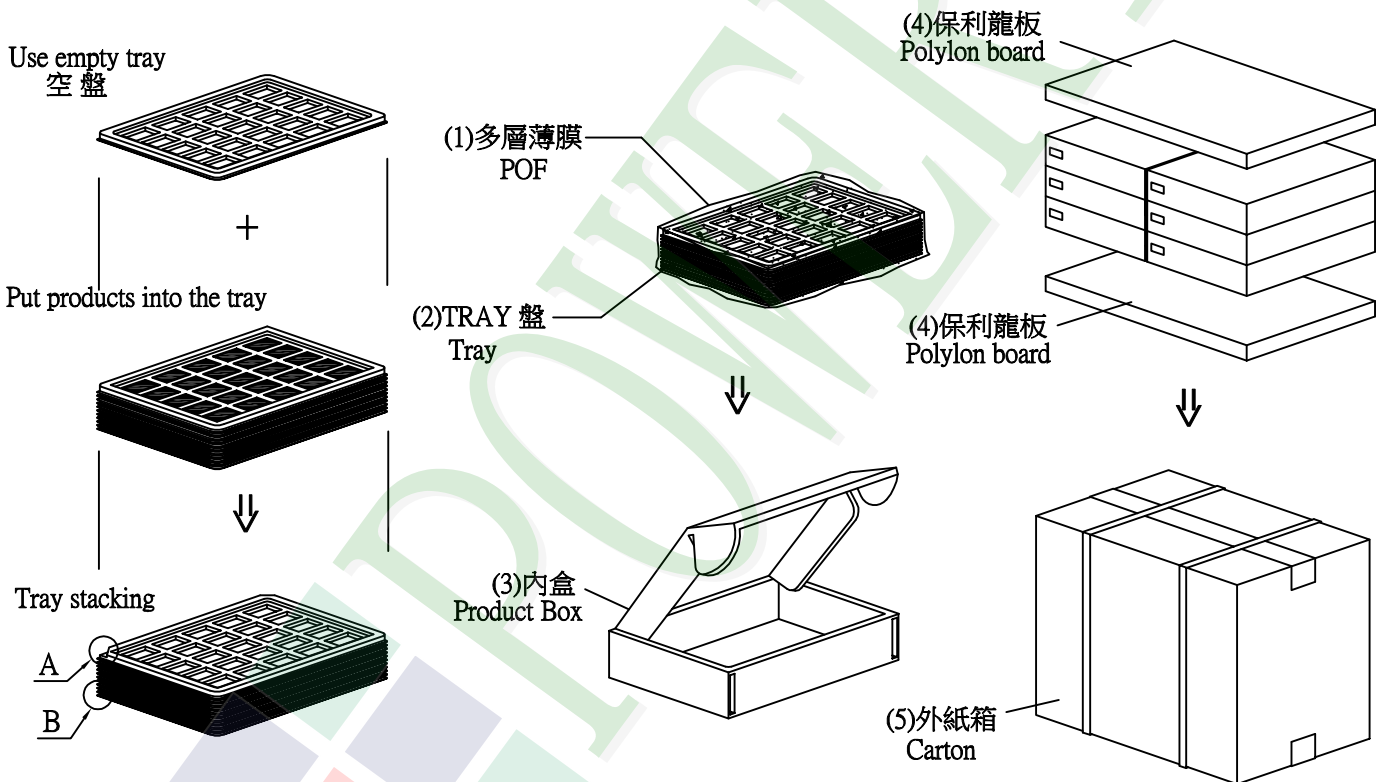

## 特 記 事 項 (REMARK)

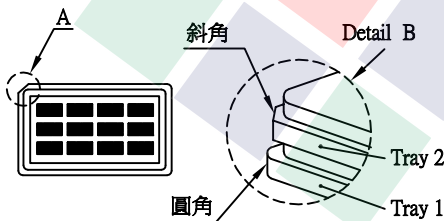

4. TRAY盤相疊時,需旋轉180度,請詳見B視圖  
Rotate tray 180 degrees and place on top of stack.  
Check the tray stack using Fig. B.