

GNSS Positioning Module

TAU1105

Datasheet V1.5

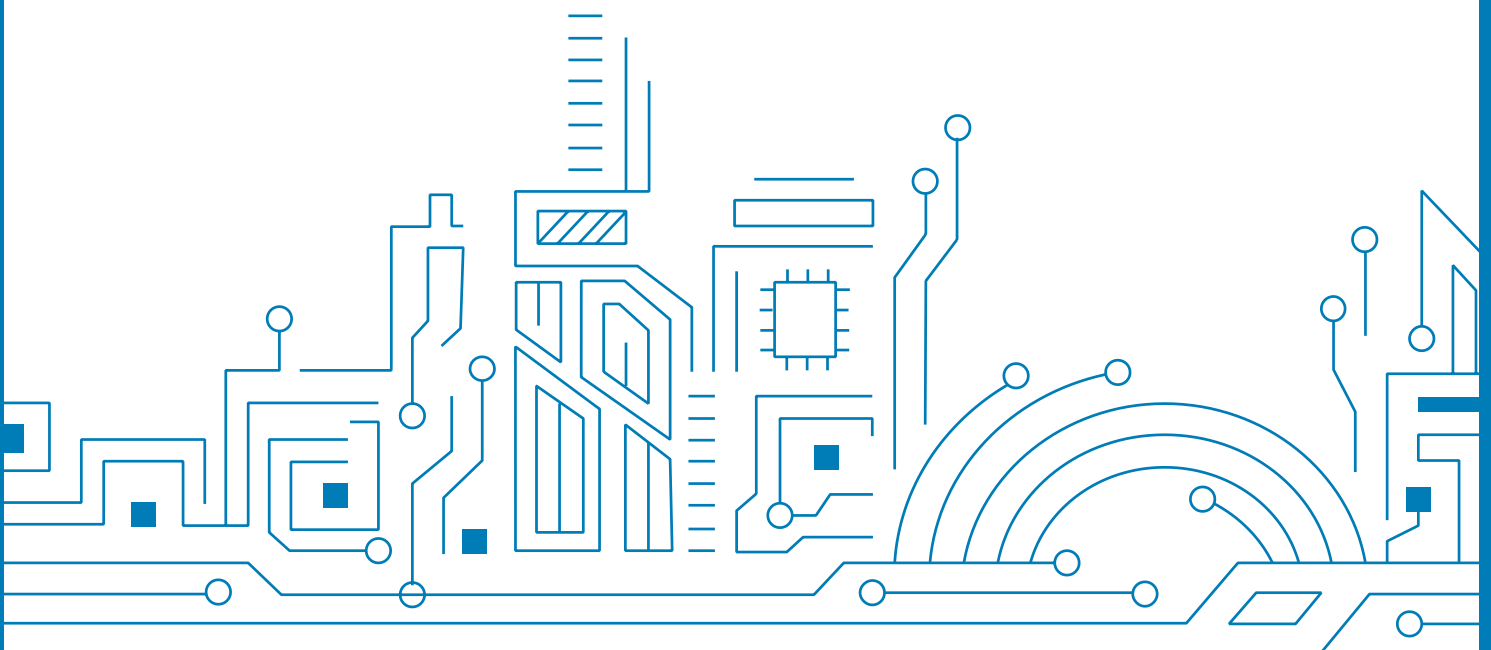

Notice, Statement and Copyright

ALLYSTAR Technology offers this document as a service to its customers, to support application and engineering efforts that use the products designed by ALLYSTAR Technology. Products and specifications discussed herein are for reference purposes only. Performance characteristics listed in this document do not constitute a warranty or guarantee of product performance.

ALLYSTAR Technology assumes no liability or responsibility for any claims or damages arising out of the use of this document, or from the use of integrated circuits based on this document, including, but not limited to claims or damages based on infringement of patents, copyrights or other intellectual property rights.

This document contains proprietary technical information which is the property of ALLYSTAR Technology, copying of this document and giving it to others and using or communication of the contents thereof, are forbidden without express authority. Offenders are liable to the payment of damages. ALLYSTAR Technology reserves the right to make changes in its products, specifications and other information at any time without notice.

For more documents, please visit www.allystar.com.

Copyright © ALLYSTAR Technology (Shenzhen) Co., Ltd. 2022. All rights reserved.

About the Document

■ Basic info

Document applies to	TAU1105
Document type	Datasheet
Revision and date	V1.5/2022-10
Product status	Mass production

■ Product status description

In development	Objective specification. Revision may be released in later status.
Engineering sample	Product specifications tested on early. Revision may be released in later status.
Preliminary	Product specifications come from small production. Revision may be released in later status.
Mass production	Final product specification to mass market.

TABLE OF CONTENT

1	SYSTEM OVERVIEW	7
1.1	Overview	7
1.2	Features	7
1.3	Module Photo.....	7
1.4	Block Diagram.....	8
1.5	Specifications	9
2	PIN DESCRIPTION	10
2.1	Pin Assignment.....	10
2.2	Detailed Pin Descriptions	11
3	ELECTRICAL CHARACTERISTICS	12
3.1	Absolute Maximum Rating	12
3.2	IO Characteristics	12
3.2.1	PRRSTX and PRTRG	12
3.2.2	Others	12
3.3	DC Characteristics	13
3.3.1	Operating Conditions	13
3.3.2	Power Consumption.....	13
4	HARDWARE DESCRIPTION	14
4.1	Connecting Power.....	14
4.2	Power on/off Sequence	14
4.2.1	Initial system power on.....	14
4.2.2	Main power supply off/on in application.....	15
4.3	Antenna Design.....	15
4.4	Reset and Mode Control	16
5	DEFAULT MESSAGE.....	17
6	MECHANICAL SPECIFICATION.....	18
7	REFERENCE DESIGN.....	19
7.1	Minimal Design	19
7.2	PCB Footprint Reference	20
7.3	Layout Notes	20
8	REFLOW SOLDERING.....	21
9	PRODUCT PACKAGING AND HANDLING.....	22
9.1	Packaging	22

9.1.1	Packaging Notes	22
9.1.2	Tape and Reel	22
9.1.3	Shipment Packaging	23
9.2	Storage	24
9.3	Handling	24
9.3.1	ESD Handling Precautions	24
9.3.2	ESD Protection Measures	24
9.3.3	Moisture Sensitivity Level	24
10	LABELING AND ORDERING INFORMATION	25
10.1	Labeling	25
10.2	Ordering info	25
11	RELATED DOCUMENTS	25
12	REVISION HISTORY	26

List of tables

Table 1	TAU1105	7
Table 2	Specifications	9
Table 3	Detailed pin descriptions	11
Table 4	Absolute rating	12
Table 5	PRRSTX and PRTRG	12
Table 6	Others	12
Table 7	Operating conditions	13
Table 8	Power consumption	13
Table 9	ANT_BIAS current range and antenna status	15
Table 10	Default message	17
Table 11	Dimensions	18
Table 12	Reflow profile features	21
Table 13	Packing hierarchy	22
Table 14	Labeling content	25
Table 15	Ordering codes	25

List of figures

Figure 1	TAU1105 module photo	7
Figure 2	Block diagram	8
Figure 3	Pin assignment (top view)	10
Figure 4	Initial system power on sequence	14
Figure 5	Main power on sequence	15
Figure 6	Dimensions	18
Figure 7	Minimal application diagram	19

Figure 8 PCB Footprint Reference.....	20
Figure 9 Reflow soldering profile (Refer to IPC/JEDEC J-STD-020E).....	21
Figure 10 Tape dimensions	22
Figure 11 Reel dimensions	23
Figure 12 Packaging	23

1 SYSTEM OVERVIEW

1.1 Overview

TAU1105 is a GNSS positioning module, which is based on the state of art CYNOSURE III architecture. It supports GPS, BeiDou, Galileo, GLONASS, and QZSS.

TAU1105 integrates efficient power management architecture, while providing high sensitivity and low power GNSS solutions which make it suitable for navigation applications on automotive and consumer electronics, and fleet management.

1.2 Features

- Concurrent reception of GPS, BDS, GLONASS, Galileo, and QZSS
- High sensitivity design and low power management
- Smart jammer detection and suppression
- Highly integrated labelling module, the best cost-effective GNSS solution

Table 1 TAU1105

Product	GNSS						Feature					Interface			Accuracy		Grade			
	Band (S/D/T)	GPS	BDS	GLONASS	Galileo	NavIC	Built-in LNA	Programmable (flash)	Data logging	D-GNSS	Oscillator	UART	I2C	USB	SPI	Meter	Sub-meter	Centimeter	Industrial	Automotive
TAU1105-1010A00E	S	●	●	●	●		●	●	●	●	T	●	○			●			●	

T = TCXO

○ = Supported upon request with special firmware

1.3 Module Photo



Figure 1 TAU1105 module photo

1.4 Block Diagram

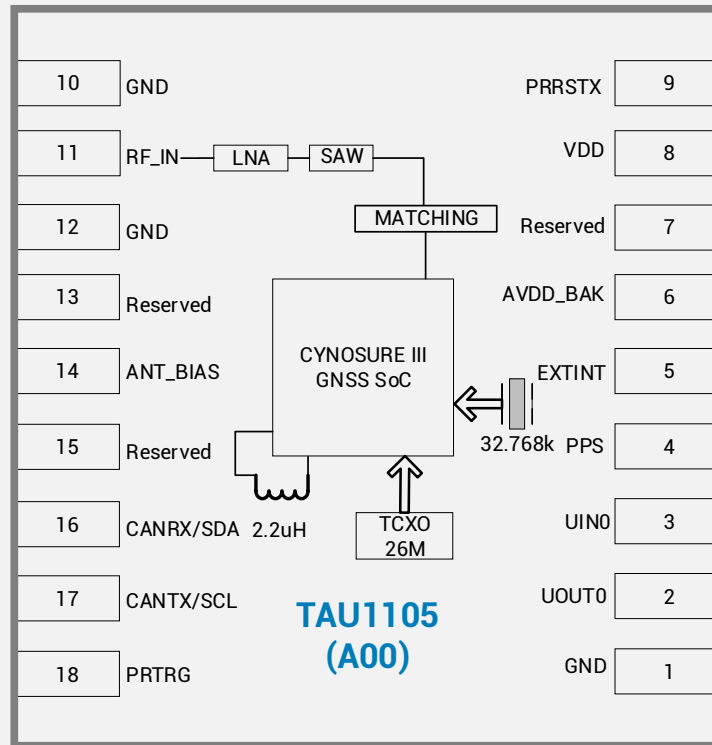

Figure 2 Block diagram

1.5 Specifications

Table 2 Specifications

Parameter	Specification	
GNSS tracking channels	40	
GNSS reception	GPS/QZSS: L1C/A	
	BDS: B1I	
	GLONASS: G1	
	Galileo: E1	
Update rate	Maximum 5 Hz	
Position accuracy ^[1]	GNSS	1m CEP
Velocity & Time accuracy	GNSS	0.1 m/s CEP
	1PPS	20 ns
Time to First Fix (TTFF)	Hot start	1 sec
	Cold start	28 secs
Sensitivity	Cold start	-148 dBm
	Hot start	-155 dBm
	Reacquisition	-158 dBm
	Tracking & navigation	-162 dBm
Operating limit	Velocity	515 m/s
	Altitude	18,000m
Antenna supervision	Antenna short circuit protection and open circuit detection	
Serial interface	UART	1
	I2C ^[2]	1
Protocol	NMEA 0183 Protocol Ver. 4.00/4.10 RTCM 3.0/3.2/2.3/2.4x ^[3] Cynosure GNSS Receiver Protocol	
Operating condition	Main voltage	2.0-3.6 V
	Digital I/O voltage	1.8-3.6 V
	Backup voltage	1.8-3.6 V
Power consumption	GPS/QZSS	25 mA @ 3.3V
	GNSS	35 mA @ 3.3V
	Standby	12 uA
Operating temperature	-40°C to +85°C	
Storage temperature	-40°C to +85°C	
Package	10.1*9.7*2.5 mm 18-pin stamp hole	
Certification	RoHS, REACH, FCC, CE-RED	

* [1] Open sky, demonstrated with a good external LNA

* [2] Supported upon request with special firmware

* [3] RTCM 2.3/2.4x are supported upon request with firmware.

2 PIN DESCRIPTION

2.1 Pin Assignment

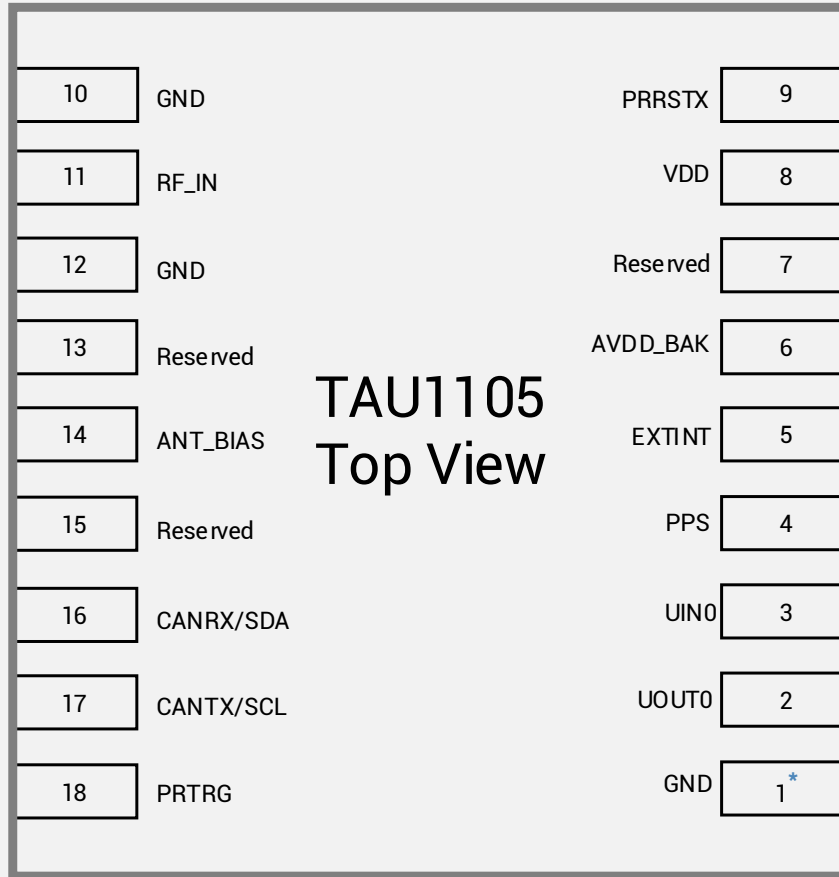

* Pin 1 aligns to the circular hole on module cover.

Figure 3 Pin assignment (top view)

2.2 Detailed Pin Descriptions

Table 3 Detailed pin descriptions

Function	Symbol	No.	I/O	Description
Power	VDD	8	Power	Main supply input.
	GND	1, 10, 12	VSS	Ground
	AVDD_BAK	6	Power	Backup supply input.
Antenna	RF_IN	11	I	RF signal input. Use a controlled impedance of 50Ω for the routing from RF_IN pin to the antenna or the antenna connector.
	ANT_BIAS	14	O	RF section output voltage. Used to power the external active antenna. The current is limited below 35 mA.
UART	UOUT0	2	O	UART0 serial data output.
	UIN0	3	I	UART0 serial data input.
I ² C/CAN ^[1]	CANRX/SDA	16	I/O	I ² C data transmission or CAN data input. Leave it floating if not used.
	CANTX/SCL	17	I/O	I ² C clock, or CAN data output. Leave it floating if not used.
System	PRTRG	18	I	Mode selection, or the trigger input in deep sleep mode to wake up the system
	PRRSTX	9	I	Low active Connect this pin to the Host
	PPS	4	O	Setting for time pulse output (PPS)
	EXTINT	5	I	GPIO, Default (EXTINT): a trigger pin to external interrupt, leave it floating if not used.
Reserved	Reserved	7, 13, 15	--	Reserved, leave it floating if not used

* [1] Supported upon request with special firmware.

3 ELECTRICAL CHARACTERISTICS

3.1 Absolute Maximum Rating

Table 4 Absolute rating

Symbol	Parameter	Min.	Max.	Unit
VDD	Power input for the main power domain	-0.5	3.63	V
AVDD_BAK	Power input for the backup power domain	-0.5	3.63	V
T _{storage}	Storage temperature	-40	85	°C
T _{solder}	Solder reflow temperature	--	260	°C

3.2 IO Characteristics

3.2.1 PRRSTX and PRTRG

Table 5 PRRSTX and PRTRG

Symbol	Parameter	Condition	Min.	Typ.	Max.	Unit
I _{IZ}	Input leakage current	--	--	--	+/-1	uA
V _{IH}	Input high voltage	--	AVDD_BAK*0.7	--	AVDD_BAK	V
V _{IL}	Input low voltage	--	0	--	AVDD_BAK*0.3	V
C _i	Input capacitance	--	--	--	10	pF
R _{PU}	Pull-up resistance	--	18	--	84	KΩ

3.2.2 Others

Table 6 Others

Symbol	Parameter	Condition	Min.	Typ.	Max.	Unit
I _{IZ}	Input leakage current	--	--	--	+/-1	uA
V _{IH}	Input high voltage	--	VDD*0.7	--	VDD	V
V _{IL}	Input low voltage	--	0	--	VDD*0.3	V
V _{OH}	Output high voltage	I _{OH} = 11.9 mA, VDD = 3.3V	2.64	--	--	V
V _{OL}	Output low voltage	I _{OL} = 7.9 mA, VDD = 3.3V	--	--	0.4	V
C _i	Input capacitance	--	--	--	11	pF
R _{PU}	Pull-up resistance	--	35	--	84	KΩ

3.3 DC Characteristics

3.3.1 Operating Conditions

Table 7 Operating conditions

Symbol	Parameter	Min.	Typ.	Max.	Unit
VDD	Power input for the main power domain	2.0	3.3	3.6	V
AVDD_BAK	Power input for the backup power domain	1.8	3.3	3.6	V
I _{ANT_BIAS}	ANT_BIAS output current	--	--	35	mA
V _{ANT_BIAS}	ANT_BIAS output voltage	--	VDD-0.2	--	V
I _{CCmax}	Maximum operating current @ VDD	--	--	200	mA
T _{env}	Operating temperature	-40	--	85	°C

3.3.2 Power Consumption

Table 8 Power consumption

Symbol	Parameter	Measure Pin	Typ.	Unit
I _{CCR1}	Average tracking current (GPS/QZSS)	VDD ^[1]	25	mA
I _{CCR2}	Average tracking current (GNSS)	VDD ^[1]	35	mA
I _{CCDBM}	Standby mode	AVDD_BAK ^[2]	12	uA

* [1] Condition: VDD = 3.3V @ Room Temperature; All Pins Open.

* [2] Condition: AVDD_BAK = 3.3V @ Room Temperature; All Pins Open.

4 HARDWARE DESCRIPTION

4.1 Connecting Power

TAU1105 positioning module has two power supply pins: VDD and AVDD_BAK. The VDD pin provides the main supply voltage, and the AVDD_BAK pin provides the backup supply voltage. In order to ensure the positioning performance, please control the ripple of the module power supply. It is recommended to use the LDO above 200 mA.

If the power for VDD pin is off, the real-time clock (RTC) and battery backed RAM (BBR) are supplied through the AVDD_BAK pin. Thus, orbit information and time can be maintained and will allow a Hot or Warm start. If no backup battery is connected, the module performs a cold start at every power up if not aiding data are sent to the module.

Note: If no backup supply is available, connect AVDD_BAK pin to VDD or leave it floating.

4.2 Power on/off Sequence

TAU1105 has two independent power domains (backup and main domain). In data backup mode, main power supply can be completely shut down for further power reduction for ultra-low power application.

To meet the requirement of controlling the power on/off sequence of the module, please connect the external reset pin (PRRSTX) to the Host.

4.2.1 Initial system power on

When both backup and main supply power on from their off state, external reset (PRRSTX) must be active and hold more than 5 ms after both backup supply and main supply reach the minimum operating voltage. Initial system power on sequence is illustrated in Figure 4.

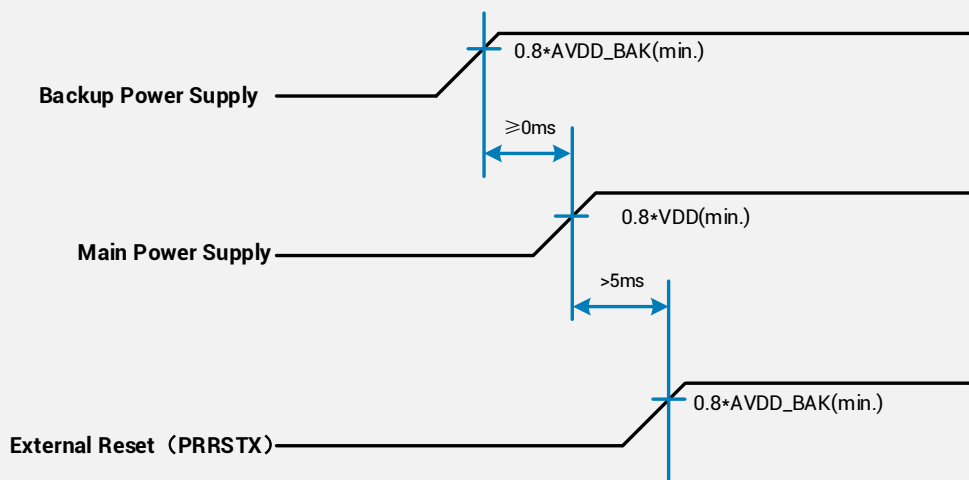

Figure 4 Initial system power on sequence

4.2.2 Main power supply off/on in application

If application intends to shut down main power supply (VDD) while keep backup power supply (AVDD_BAK) alive to save backup data, the following rules should be applied:

External reset (PRRSTX) must be active when main power supply is under power off. In this case, external reset must be hold active more than 5 ms after main power supply resumes to minimum operating voltage. Main power on sequence in application is illustrated in Figure 5.

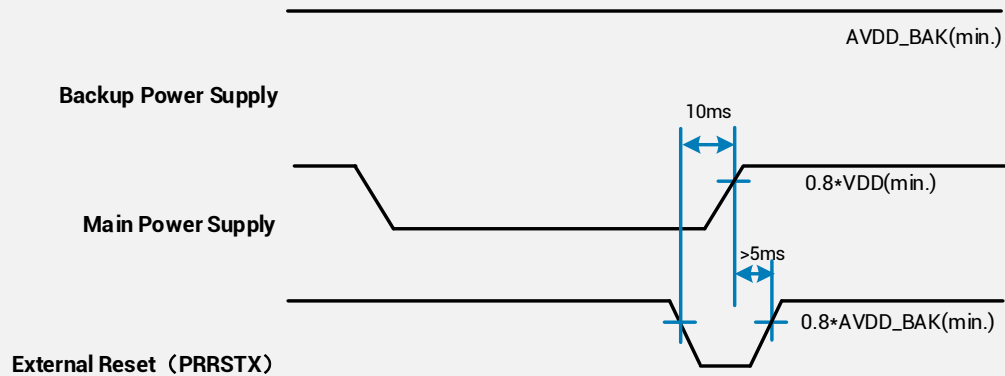

Figure 5 Main power on sequence

4.3 Antenna Design

There is a built-in LNA and SAW in the GNSS module. It is recommended to use an active antenna with gain less than 36 dB and the noise figure less than 1.5 dB.

The module has built-in short circuit detection and open circuit detection function, which can detect the status of normal connection, and send out antenna status prompt message in NMEA data.

- Short circuit protection
 - » The module includes internal short circuit antenna detection. Once an overcurrent is detected at the ANT_BIAS port, the module will restrict current output automatically to protect from damages.
- Open circuit detection
 - » The module can detect an open circuit in the antenna. Users can judge it from antenna status messages.

Table 9 ANT_BIAS current range and antenna status

Antenna status	Status output	ANT_BIAS current range
Open circuit	OPEN	$0 < \text{ANT_BIAS} \leq 1 \text{ mA}$
Regular circuit or open circuit	OK or OPEN	$1 \text{ mA} < \text{ANT_BIAS} \leq 2 \text{ mA}$
Regular circuit	OK	$2 \text{ mA} < \text{ANT_BIAS} \leq 40 \text{ mA}$
Short circuit	SHORT	$\text{ANT_BIAS} > 40 \text{ mA}$

TIPs:

1. Pulse width of the minimum detectable overshoot current should be more than 10 uS.
2. NMEA message of antenna status output:
 - OPEN: \$GNTXT,01,01,01,**ANT_OPEN***40
 - OK: \$GNTXT,01,01,01,**ANT_OK***50
 - SHORT: \$GNTXT,01,01,01,**ANT_SHORT***06

4.4 Reset and Mode Control

The operation mode of GNSS module is controlled by PRRSTX (nRESET) and PRTRG (BOOT) pin. While the module works in normal operation, keep PRRSTX and PRTRG pins at high level. The module will enter reset state when PRRSTX being low level. Operate PRTRG and PRRSTX pins as the following instructions to enter **BootROM Command Mode** to update firmware.

- Keep PRTRG pin floating during system power-up or the external reset (PRRSTX from low to high), and the module will enter **User Normal Mode**.
- When the module powers up or PRRSTX from low to high, the module will execute an **external reset**. (If the power for AVDD_BAK is always on, the external reset will not affect the ephemeris data in the backup domain)
- Drive PRTRG pin to low or connect PRTRG to GND directly (not by pull-down resistance) during system power-up or the external reset (PRRSTX from low to high), and the system enters **BootROM Command Mode** at PRTRG pin being released from low to floating state, and ready for firmware upgrading command.
- When connecting PRRSTX and PRTRG to any host IO, DO NOT use the pull-up or pull-down resistance.

5 DEFAULT MESSAGE

Table 10 Default message

Interface	Settings
UART output	Data format: 1 start bit, 8 data bits, 1 stop bit, no checksum Default baud rate: 115200 bps. Configured to transmit both NMEA and HD Binary protocols, but only the following NMEA (and no HD Binary sentence) messages have been activated at start-up: GGA, GSA, GSV, RMC, ZDA, TXT-ANT
UART input	115200 baud, 8 data bits, no parity bit, 1 stop bit, autobauding disabled Automatically accepts the following protocols without need of explicit configuration: HD binary sentence, NMEA, RTCM The GNSS receiver supports interleaved HD binary and NMEA messages.
Timepulse (1 Hz Nav)	1 pulse per second, synchronized at rising edge, pulse length 100 ms

* Refer to *GNSS_Protocol_Specification* for information about other settings.

When the module is applied to the specific application where the main supply needs to be cut, in this case, it is recommended to cut the serial interface connection at the same time or set the serial port to input mode or high impedance state.

6 MECHANICAL SPECIFICATION

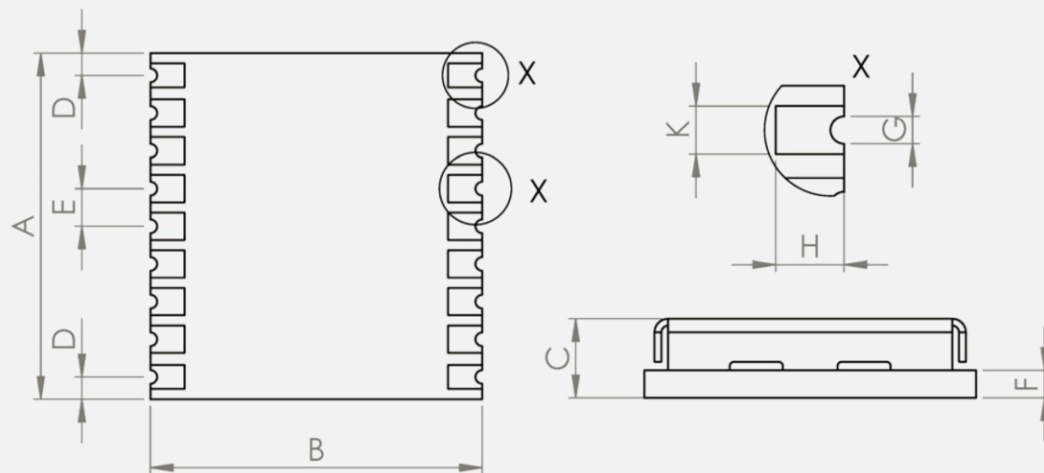

Figure 6 Dimensions

Table 11 Dimensions

Symbol	Min. (mm)	Typ.(mm)	Max. (mm)
A	9.9	10.1	10.3
B	9.5	9.7	9.9
C	2.3	2.5	2.7
D	0.55	0.65	0.95
E	1.0	1.1	1.2
F	0.6	0.8	--
G	0.4	0.5	0.6
H	0.8	0.9	1.0
K	0.7	0.8	0.9

7 REFERENCE DESIGN

7.1 Minimal Design

This is a minimal design for a TAU1105 GNSS module. When connecting to an active antenna, make sure there is an 82 nH (L1) inductance soldered as shown in the following figure. When it is connected to a passive antenna, there is no need for the 82 nH inductance. The characteristic impedance from RF_IN pin to the antenna connector should be 50Ω.

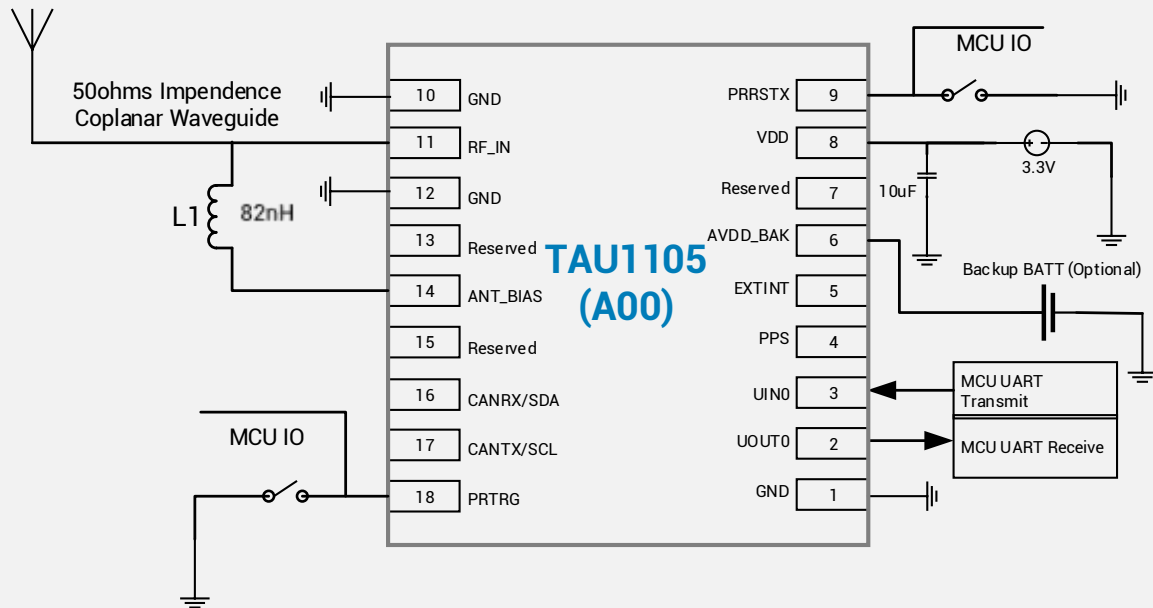

Figure 7 Minimal application diagram

7.2 PCB Footprint Reference

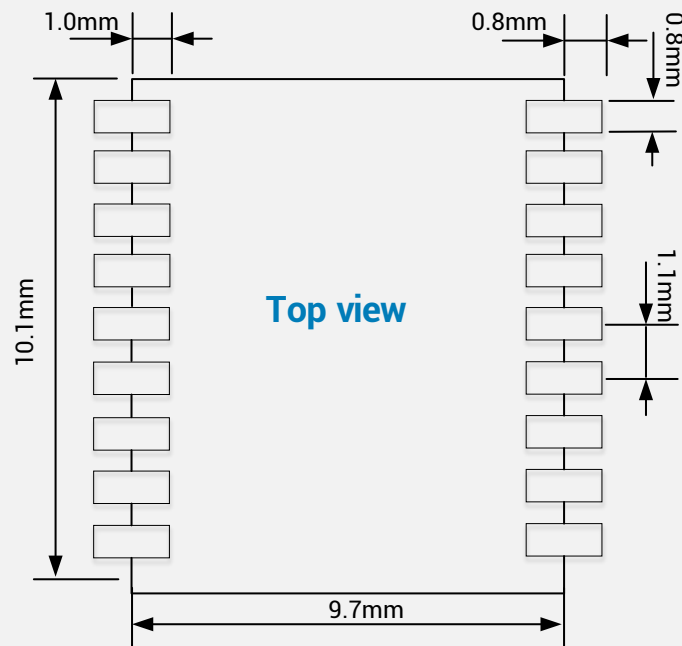

Figure 8 PCB Footprint Reference

7.3 Layout Notes

- (1) A decoupling capacitor should be placed close to VDD pin of the module, and the width of power routing should be more than 0.5 mm.
- (2) The width of RF routing between RF port to antenna interface should be wider than 0.2 mm. The characteristic impedance of RF routing between RF port to antenna interface should be controlled to 50Ω.
- (3) It is recommended that the routing from RF port to antenna interface refers to the second layer, and no routing are recommended on the layer.
- (4) Do not place the module close to any EMI source, like antenna, RF routing, DC/DC or power conductor, clock signal or other high-frequency switching signal, etc.

8 REFLOW SOLDERING

Table 12 Reflow profile features

Profile Feature	Pb-Free Assembly
Preheat/Soak	
Temperature Min (T_{smin})	150°C
Temperature Max (T_{smax})	200°C
Time (t_s) from (T_{smin} to T_{smax})	60-120 s
Ramp-up rate (T_L to T_p)	3°C/second max.
Liquidous temperature (T_L)	217°C
Time (t_L) maintained above T_L	60-150 s
Peak package body temperature (T_p)	must not exceed the Classification temp T_c ^[1]
Time (t_p)* within 5°C of the specified classification temperature (T_c)	30* seconds ^[2]
Ramp-down rate (T_p to T_L)	6°C/second max.
Time 25°C to peak temperature	8 minutes max.

* [1] $T_c = 260^\circ\text{C}$.

* [2] The time above 255°C must not exceed 30 seconds.

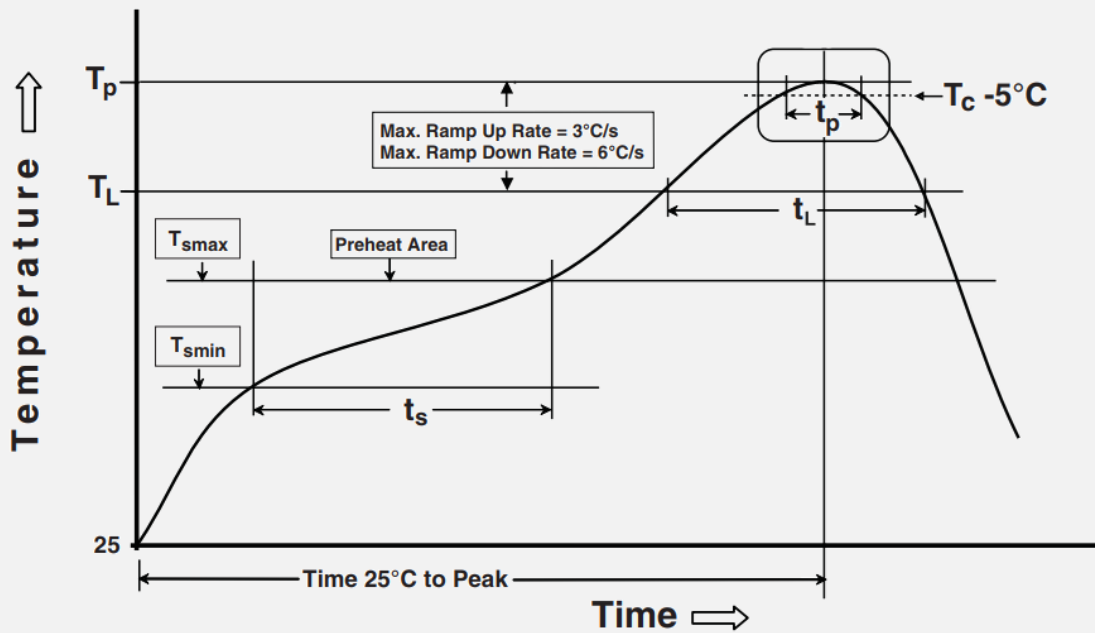
Figure 9 Reflow soldering profile (Refer to IPC/JEDEC J-STD-020E)





9 PRODUCT PACKAGING AND HANDLING

9.1 Packaging

9.1.1 Packaging Notes

TAU1105 GNSS module is a Moisture Sensitive Device (MSD) and Electrostatic Sensitive Device (ESD). During the packing and shipping, it is strictly required to take appropriate MSD handling instructions and precautions. The table below shows the general packing hierarchy for the standard shipment.

Table 13 Packing hierarchy

Module	Reel	Sealed bag	Shipping carton
			

9.1.2 Tape and Reel

The TAU1105 modules are delivered as hermetically sealed, reeled tapes in order to enable efficient production, production lot set-up and tear-down. The figure below shows the tape dimensions.

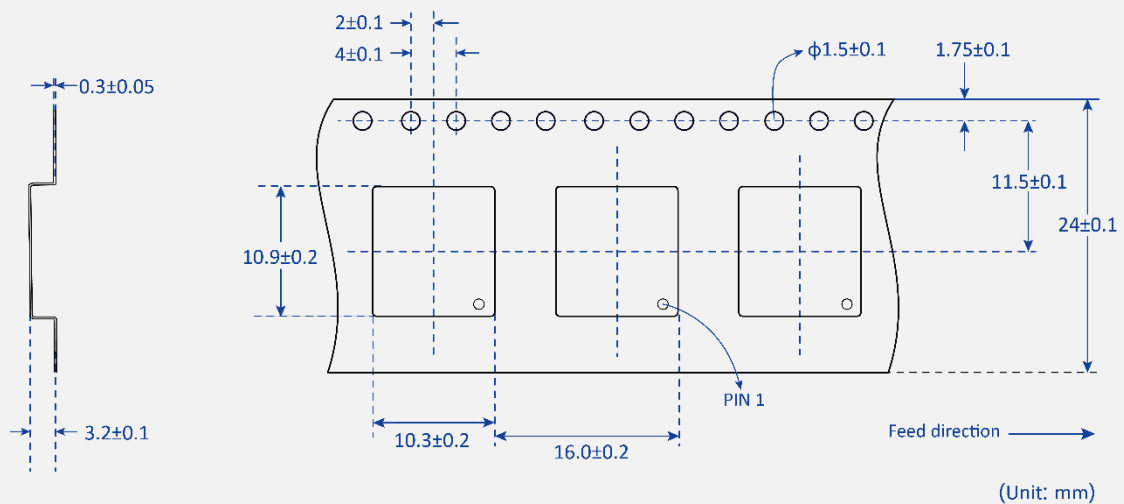

Figure 10 Tape dimensions

TAU1105 modules are deliverable in quantities of 1000 pcs on a reel. The figure below shows the dimensions of reel for TAU1105.

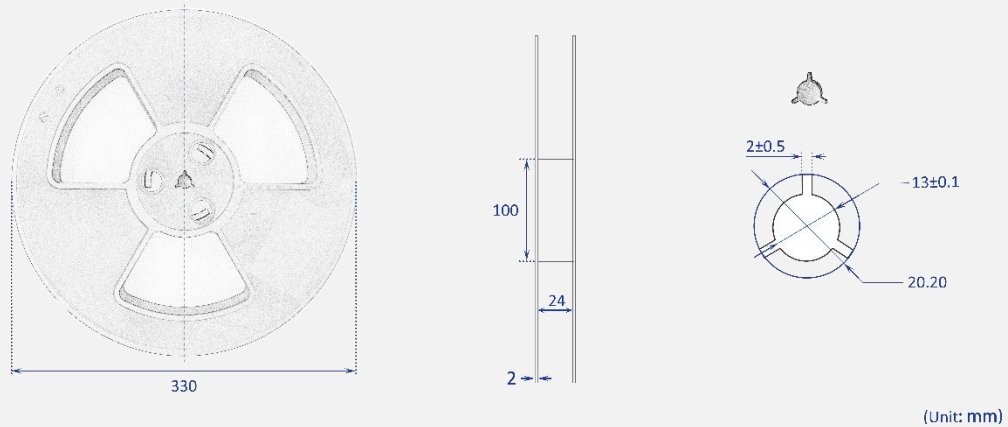

Figure 11 Reel dimensions

9.1.3 Shipment Packaging

The reels of TAU1105 modules are packed in the sealed bags and shipped by shipping cartons. Up to five sealed bags (5000 pcs in total) can be packed in one shipping carton.

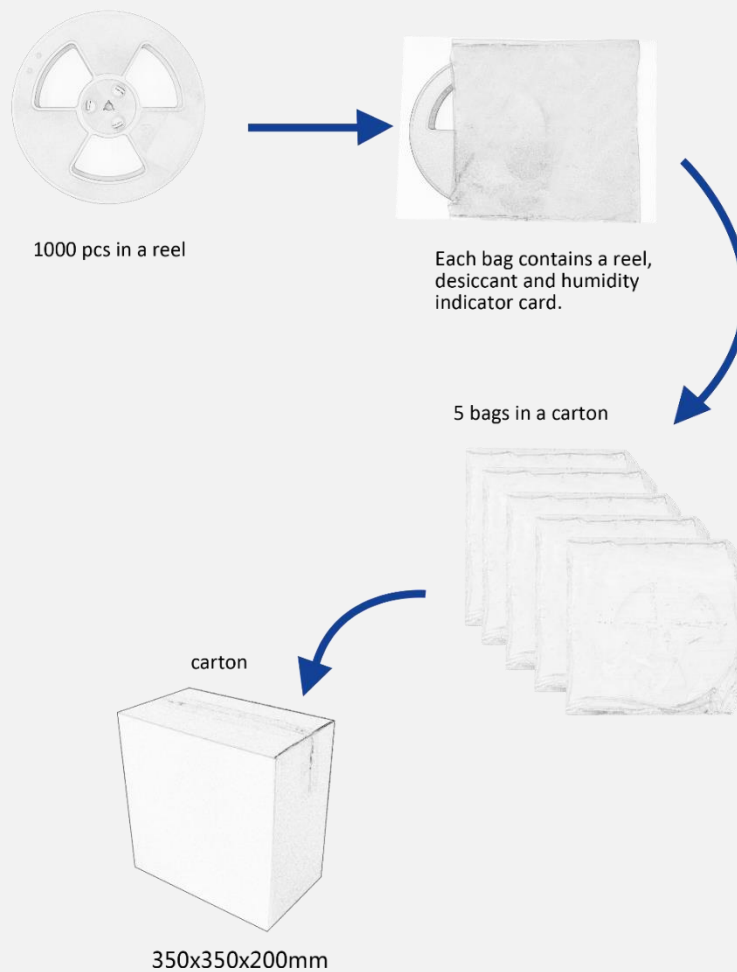

Figure 12 Packaging

9.2 Storage

In order to prevent moisture intake and protect against electrostatic discharge, TAU1105 is packaged together with a humidity indicator card and desiccant to absorb humidity.

9.3 Handling

9.3.1 ESD Handling Precautions

TAU1105 module which contains highly sensitive electronic circuitry is an Electrostatic Sensitive Device (ESD). Observe precautions for handling! Failure to observe these precautions may result in severe damage to the GNSS module!

- Unless there is a galvanic coupling between the local GND (i.e. the workbench) and the PCB GND, then the first point of contact when handling the PCB must always be between the local GND and PCB GND.
- Before mounting an antenna patch, connect ground of the device.
- When handling the RF pin, do not come into contact with any charged capacitors and be careful when contacting materials that can develop charges (e.g. patch antenna ~10 pF, coax cable ~50 - 80 pF/m, soldering iron...)
- To prevent electrostatic discharge through the RF input, do not touch any exposed antenna area. If there is any risk that such exposed antenna area is touched in non ESD protected work area, implement proper ESD protection measures in the design.
- When soldering RF connectors and patch antennas to the receiver's RF pin, make sure to use an ESD safe soldering iron (tip).



9.3.2 ESD Protection Measures

The GNSS positioning module is sensitive to static electricity. Whenever handling the module, particular care must be exercised to reduce the risk of electrostatic charges. In addition to standard ESD safety practices, the following measures should be taken into account.

- Add ESD Diodes to the RF input part to prevent electrostatics discharge.
- Do not touch any exposed antenna area.
- Add ESD Diodes to the UART interface.

9.3.3 Moisture Sensitivity Level

The Moisture Sensitivity Level (MSL) of the GNSS module is MSL3.

10 LABELING AND ORDERING INFORMATION

Labeling and ordering information help customers get more about Allystar products.

10.1 Labeling

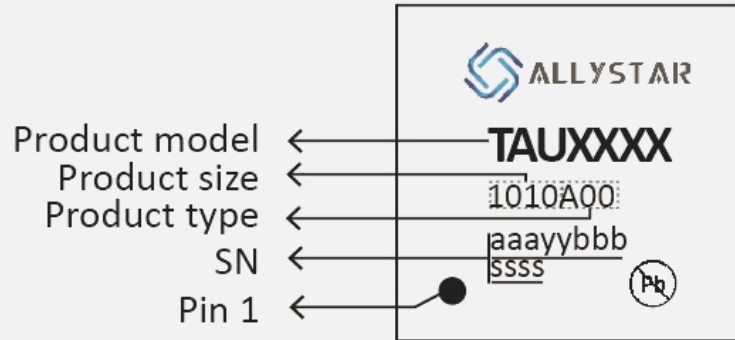

Table 14 Labeling content

Symbol	Explanation	Instance
TAUXXXX	Product model	TAU1105
1010A00	1010 represents the product size.	1010A00
	A00 means the product type.	
aaayybbbssss	Serial number.	351190010001

10.2 Ordering info

Table 15 Ordering codes

Ordering No.	Product information
TAU1105-1010A00E ^[1]	Concurrent GNSS LCC Module, TCXO, Flash, 10.1*9.7 mm, 1000 pieces/reel.

* [1] See Table 1 for the GNSS systems supported.

11 RELATED DOCUMENTS

- [1] Satrack User Manual
- [2] Allystar Common Commands
- [3] GNSS Protocol Specification

12 REVISION HISTORY

Revision	Date	Reviser	Status/Comments
V1.0	2019-08	Vita Wu	First released
V1.1	2019-09	Vita Wu	Logo and wording update
V1.2	2020-07	Vita Wu	Updates ANT_BIAS info; Adds PCB package info; Adds packaging info; Updates mechanical specification; Updates antenna gain to 36dB; Adds built-in chock in reference design; Simplifies Pin description;
V1.3	2020-12	Vita Wu	Updates MSL. Clarifies power on/off sequence. Updates AVDD_BAK connectivity description in Section 4.1. Improves mechanical specification. Improves wordings. Localization. Improves layout notes in Section 6.3. Deletes 1K resistor in the minimal design diagram. Updates description about short circuit protection.
V1.4	2021-07	Vita Wu	Adds labeling and ordering info. Details default settings. Adds related document list. Adds document info section. Removes C00 design Updates main voltage range to be 2.0V~3.6V.
V1.5	2022-10	Cao Min	Modifies the product grade classification Updates the chip name described in section 1.4 Changes the update rate and GNSS position accuracy, and adds FCC and CE-RED certification in Table 2 Modifies the MSL to MSL3 Updates the headquarters address Updates the product ordering number Optimizes the antenna bias current range in Section 4.3 Contents optimization



www.allystar.com



info.gnss@allystar.com



Headquarters

Allystar Technology (Shenzhen) Co., Ltd.

Address: 201-2, 2F, Tower F, Xinghe World, No.1, Yabao Road, LongGang District, Shenzhen City, Guangdong Province, China.

Calgary Office

Allystar Technology (Canada) Ltd.

Address: Unit 288, 3553 31 Street NW Calgary, Alberta, Canada T2L 2K7

