

FEATURES

* International standard package

APPLICATIONS

- * DC motor control
- * Softstart AC motor controller
- * Light, heat and temperature control

ADVANTAGES

- * Space and weight savings
- * Simple mounting with two screws
- * Improved temperature and power cycling
- * Reduced protection circuits

Symbol	Test Conditions	Maximum Ratings	Unit
I_{TRMS} , I_{FRMS} I_{TAVM} , I_{FAVM}	$T_{VJ}=T_{VJM}$ $T_C=85^{\circ}C$; 180° sine	400 350	A
I_{TSM} , I_{FSM}	$T_{VJ}=45^{\circ}C$ t=10ms (50Hz), sine $V_R=0$ t=8.3ms (60Hz), sine	9200 10100	A
	$T_{VJ}=T_{VJM}$ t=10ms(50Hz), sine $V_R=0$ t=8.3ms(60Hz), sine	8000 8800	
i_{zdt}	$T_{VJ}=45^{\circ}C$ t=10ms (50Hz), sine $V_R=0$ t=8.3ms (60Hz), sine	423000 423000	A _{2s}
	$T_{VJ}=T_{VJM}$ t=10ms(50Hz), sine $V_R=0$ t=8.3ms(60Hz), sine	320000 321000	
$(di/dt)_{cr}$	$T_{VJ}=T_{VJM}$ repetitive, $I_T=45A$ f=50Hz, $t_p=200\mu s$ $V_D=2/3V_{DRM}$ $I_G=0.45A$ non repetitive, $I_T=I_{TAVM}$ $di_G/dt=0.45A/\mu s$	100 500	A/ μs
	$T_{VJ}=T_{VJM}$; $V_{DR}=2/3V_{DRM}$ $R_{GK}=\ ;$ method 1 (linear voltage rise)	1000	
P_{GM}	$T_{VJ}=T_{VJM}$ $t_p=30\mu s$ $I_T=I_{TAVM}$ $t_p=300\mu s$	120 60	W
		20	
P_{GAV}		20	W
V_{RGM}		10	V
T_{VJ} T_{VJM} T_{stg}		-40...+125	°C
		125	
		-40...+125	
V_{ISOL}	50/60Hz, RMS t=1min $I_{ISOL}<1mA$ t=1s	3000 3600	V~
M_d	Mounting torque (M5) Terminal connection torque (M5)	2.5-4.0/22-35 2.5-4.0/22-35	Nm/lb.in.
Weight	Typical including screws	0.8	Kg

HUAJING**MFC350A 1600V ...SERIES**

Symbol	Test Conditions	Maximum Ratings	Unit
IRRM, IDRM	TVJ=TVJM; VR=VRRM; VD=VDRM	70	mA
VT, VF	IT, IF=350A; TVJ=25oC	1.60	V
VTO	For power-loss calculations only (TVJ=125oC)	1.7	V
rT		0.85	mΩ
VGT	VD=6V; TVJ=25oC TVJ=-40oC	2.5 2.6	V
IGT	VD=6V; TVJ=25oC TVJ=-40oC	150 200	mA
VGD	TVJ=TVJM; VD=2/3VDRM	0.25	V
IGD		10	mA
IL	TVJ=25oC; tp=10us; VD=6V IL IG=0.45A; diG/dt=0.45A/us	300	mA
IH	TVJ=25oC; VD=6V; RGK=	150	mA
tgD	TVJ=25oC; VD=1/2VDRM IG=0.45A; diG/dt=0.45A/us	2	us
tq	TVJ=TVJM; IT=20A; tp=200us; -di/dt=10A/us typ. VR=100V; dv/dt=20V/us; VD=2/3VDRM	200	us
QS	TVJ=TVJM; IT, IF=25A; -di/dt=0.64A/us	760	uC
IRM		275	A
RthJC	per thyristor/diode; DC current per module	0.129 0.0645	K/W
RthJK	per thyristor/diode; DC current per module	0.169 0.0845	K/W
dS	Creeping distance on surface	12.7	mm
dA	Strike distance through air	9.6	mm
a	Maximum allowable acceleration	50	m/s ²

Outline Table

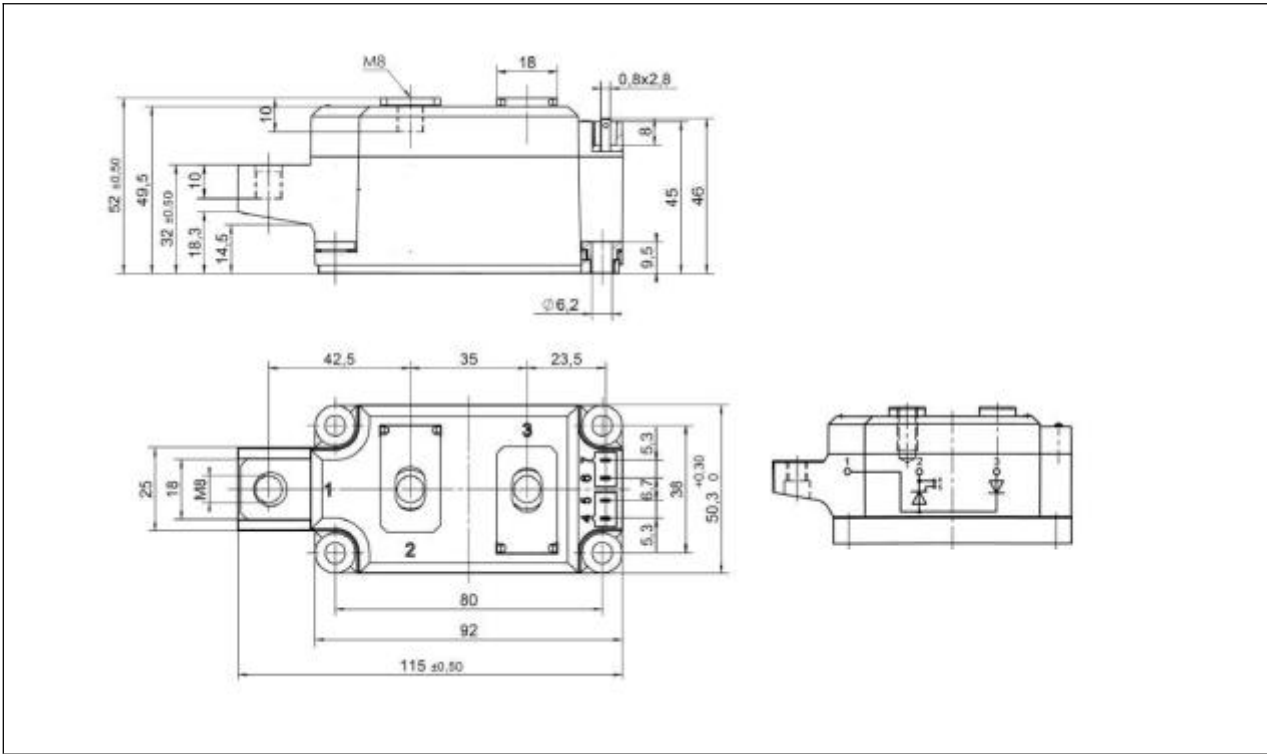

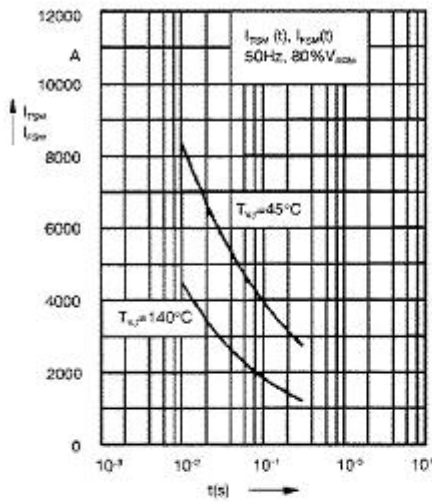

Fig. 1 Surge overload current
 I_{TSM} , I_{FSM} : Crest value, t : duration

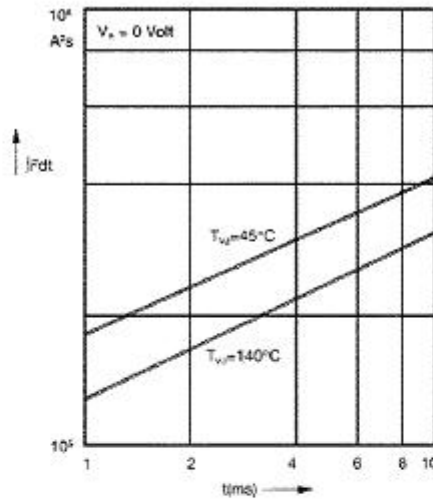

Fig. 2 $\int I^2 dt$ versus time (1-10 ms)

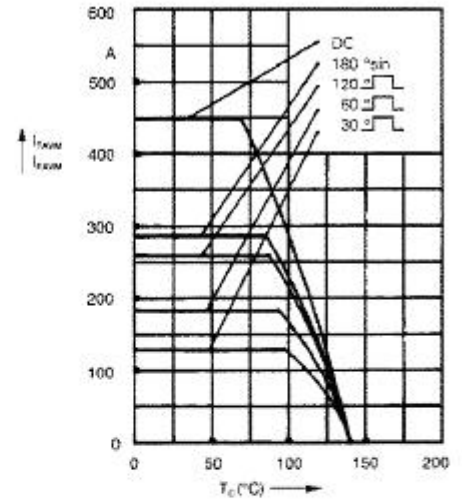

Fig. 2a Maximum forward current at case temperature

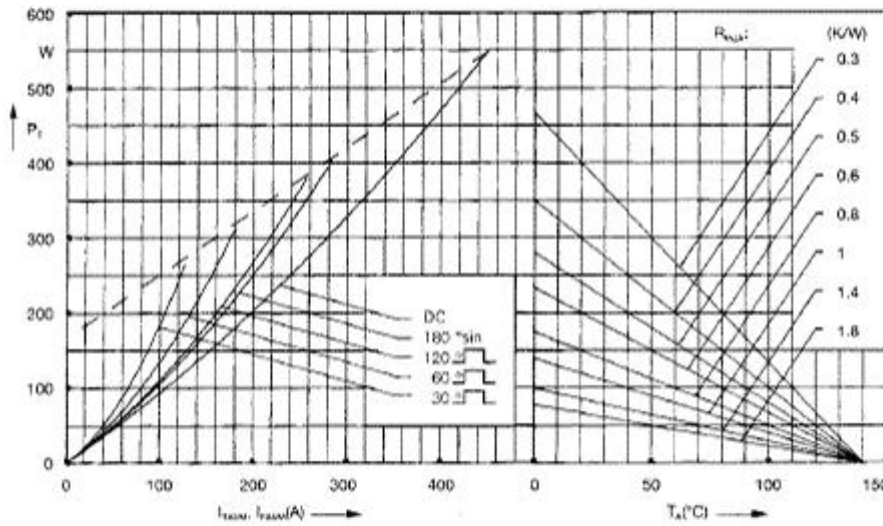

Fig. 3 Power dissipation versus on-state current and ambient temperature (per thyristor or diode)

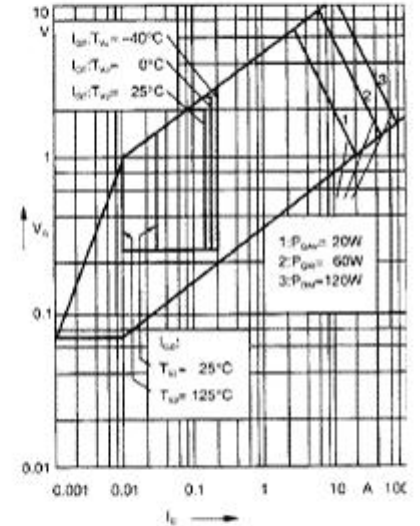

Fig. 4 Gate trigger characteristics

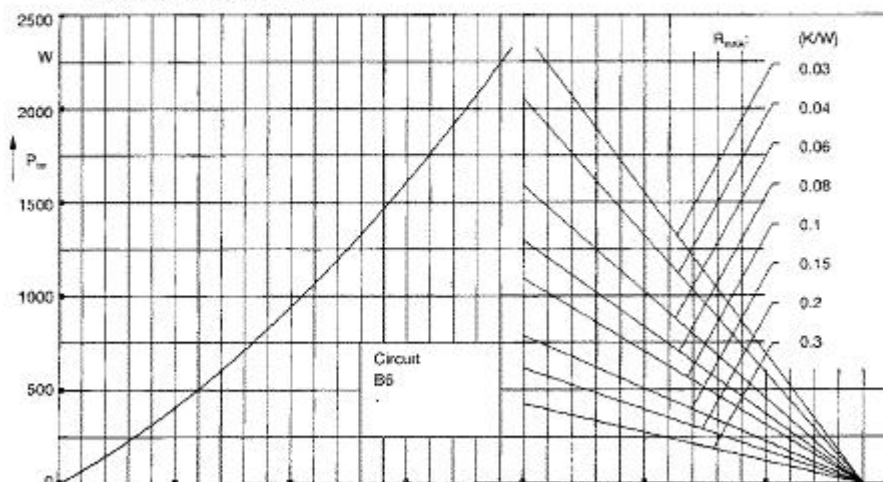

Fig. 5 Three phase rectifier bridge: Power dissipation versus direct output current and ambient temperature

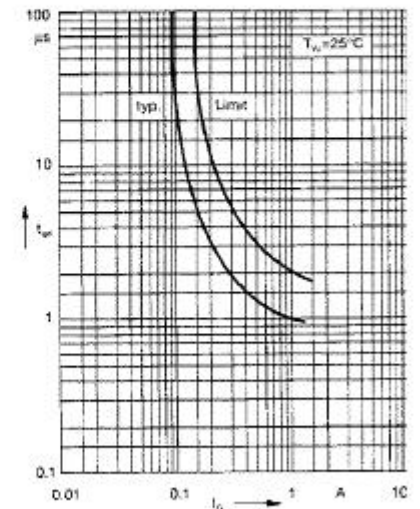

Fig. 6 Gate trigger delay time

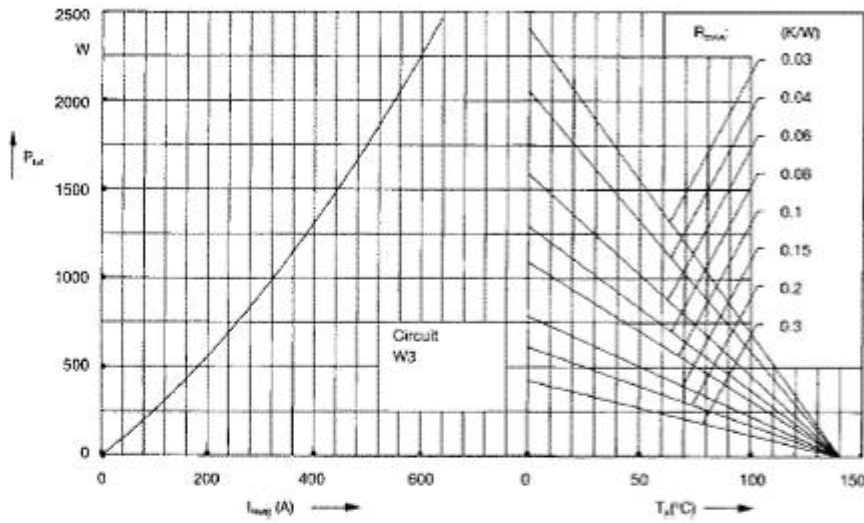

Fig. 7 Three phase AC-controller: Power dissipation versus RMS output current and ambient temperature

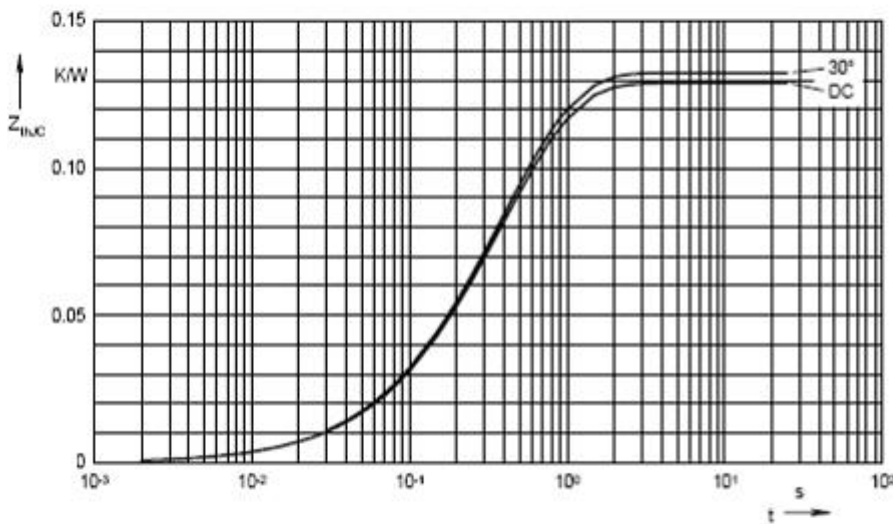

Fig. 8 Transient thermal impedance junction to case (per thyristor or diode)

R_{thJC} for various conduction angles d :

d	R_{thJC} (K/W)
DC	0.129
180°C	0.131
120°C	0.131
60°C	0.132
30°C	0.132

Constants for Z_{thJC} calculation:

i	R_{thi} (K/W)	t_i (s)
1	0.0035	0.099
2	0.0165	0.168
3	0.1091	0.456

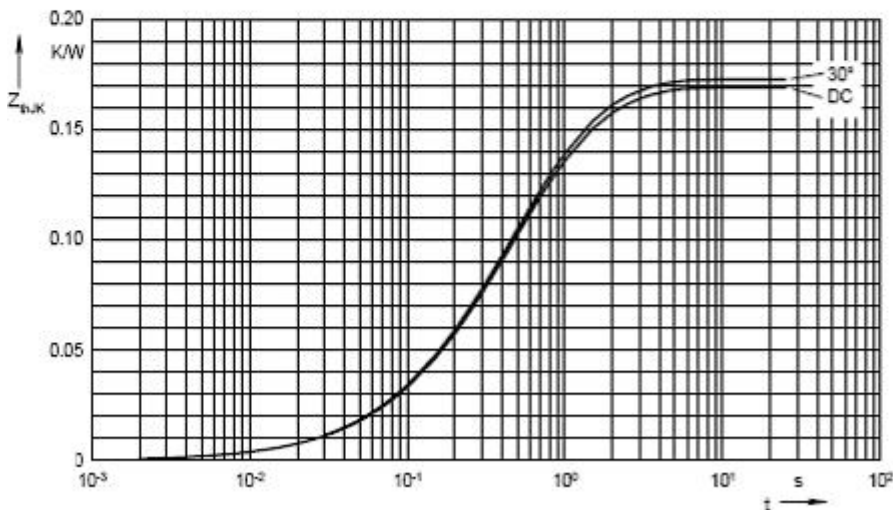

Fig. 9 Transient thermal impedance junction to heatsink (per thyristor or diode)

R_{thJK} for various conduction angles d :

d	R_{thJK} (K/W)
DC	0.169
180°C	0.171
120°C	0.172
60°C	0.172
30°C	0.173

Constants for Z_{thJK} calculation:

i	R_{thi} (K/W)	t_i (s)
1	0.0033	0.099
2	0.0159	0.168
3	0.1053	0.456
4	0.04	1.36

