

SEE SHEET 6  
FOR M3 GRIP CODE TERMINAL

CARRIER BUMP DIRECTION  
POINTS DOWN FOR TIN PLATED TERMINALS  
POINTS UP FOR PRECIOUS PLATED TERMINALS

GENERAL NOTES: (UNLESS OTHERWISE SPECIFIED)

- MATING TERMINAL SHOWN ON SD-33012-002
- MATERIAL: ASTM B422, UNS C19025, HR04  
THICKNESS: 0.30 mm +0.01  
TEMPER: FULL HARD (REF)  
TENSILE: 496-572 MPA
- TIN PLATED TERMINAL FINISH:  
OVERALL UNDERPLATE ELECTRODEPOSITED NICKEL  
OVERALL ELECTRODEPOSITED REFLOW TIN
- GOLD PLATED TERMINAL FINISH:  
OVERALL UNDERPLATE ELECTRODEPOSITED DUCTILE SULFAMATE NICKEL  
CONTACT AREA - ELECTRODEPOSITED GOLD  
GRIP AREA - ELECTRODEPOSITED 100% TIN MATTE FINISH
- SILVER PLATED TERMINAL FINISH:  
OVERALL UNDERPLATE ELECTRODEPOSITED DUCTILE SULFAMATE NICKEL  
CONTACT AREA - ELECTRODEPOSITED PURE SILVER (0.5% MAX IMPURITIES) SEMI-BRIGHT FINISH  
- SILVER ANTI-TARNISH - EVABRITE  
GRIP AREA - ELECTRODEPOSITED 100% TIN MATTE FINISH
- MEETS CRIMP PERFORMANCE SPECIFICATION SAE/USCAR-21 (8/2001)
- MEETS PERFORMANCE STANDARD FOR AUTOMOTIVE ELECTRICAL CONNECTOR SYSTEMS  
SAE/USCAR-2 REV 3 (APRIL 2001)
- MEETS FIELD CORRELATED LIFE TEST SAE/USCAR-20 (11/2001)
- MEETS WIRING COMPONENT DESIGN GUIDELINES SAE/USCAR-12 REV 2 (12/2001)
- MEETS ELECTRICAL CONNECTION SYSTEM DESIGN SPECIFICATION (SDS) REV 11 (5/2002)
- REFERENCE PK-31300-516 FOR REEL DIRECTION
- REFERENCE AS-33000-001 FOR CRIMP INFORMATION

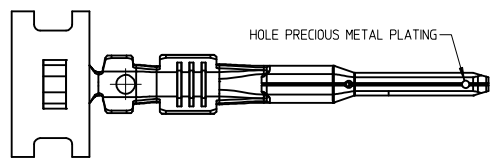

PRECIOUS METAL PLATED BLADE

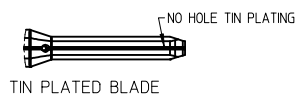

TIN PLATED BLADE

ENTER DESCRIPTION EC NO: UAU2017-1076 DRWINWENKATESHSH2017/05/24 CHKD:A. DHIR 2017/05/29 APPR:TJSMITH 2017/06/09	QUALITY SYMBOLS ▽=0 ▽=0 ▽=0	GENERAL TOLERANCES (UNLESS SPECIFIED)		DIMENSION STYLE MM ONLY		SCALE 4:1	DESIGN UNITS METRIC	THIRD ANGLE PROJECTION	
		mm	INCH	DRAWN BY L.PULLIAM	DATE 2006/01/31	TITLE MX150 15MM BLADE TERMINAL		molex	
D1	DESCRIPTION	4 PLACES ±	±	CHECKED BY A.DHIR	DATE 2006/02/01	DOCUMENT NO. SD-33000-001			
		3 PLACES ±	±	APPROVED BY B.MOSER	DATE 2006/02/02				
		2 PLACES ±	±0.10	MATERIAL NO. SEE TABLE		THIS DRAWING CONTAINS INFORMATION THAT IS PROPRIETARY TO MOLEX INCORPORATED AND SHOULD NOT BE USED WITHOUT WRITTEN PERMISSION			
		1 PLACE ±	±0.3	DRAFT WHERE APPLICABLE MUST REMAIN WITHIN DIMENSIONS					
		0 PLACE ±	±	ANGULAR ± 3 °					

FAMILY	GENDER	SEALING	PLATING	PART NUMBER	PAYOFF DIRECTION	GRIP CODE	WIRE SIZES*	A ±0.30	B ±0.30	C ±0.30	D ±0.30	SPECIAL CHARACTERISTICS
MX150	BLADE	MAT SEAL UNSEALED	Sn	33000-0001	RIGHT (B)	14	14AWG	3.9	3.8	1.7	1.6	HIGH PERFORMANCE Sn
				33000-1001	LEFT (D)		1.50-2.00mm <sup>2</sup>					
				33000-0002	RIGHT (B)	18	20/18/16AWG	3.3	3.1	1.3	1.4	
				33000-1002	LEFT (D)		0.75-1.00mm <sup>2</sup>					
				33000-0003	RIGHT (B)	22	22AWG	2.5	2.6	0.9	1.0	
				33000-1003	LEFT (D)							
				33000-0004	RIGHT (B)	M3	0.35-0.50mm <sup>2</sup>	2.5	2.7	0.9	1.54 ±0.1	
			33000-1004	LEFT (D)								
			Au	33011-1002	RIGHT (B)	14	14AWG	3.9	3.8	1.7	1.6	HIGH PERFORMANCE Au
				33011-0002	LEFT (D)		1.50-2.00mm <sup>2</sup>					
				33011-1004	RIGHT (B)	18	20/18/16AWG	3.3	3.1	1.3	1.4	
				33011-0004	LEFT (D)		0.75-1.00mm <sup>2</sup>					
				33011-1006	RIGHT (B)	22	22AWG	2.5	2.6	0.9	1.0	
				33011-0006	LEFT (D)							
				33011-1008	RIGHT (B)	M3	0.35-0.50mm <sup>2</sup>	2.5	2.7	0.9	1.54 ±0.1	
			33011-0008	LEFT (D)								
			Ag	33011-2003	RIGHT (B)	14	14AWG	3.9	3.8	1.7	1.6	HIGH PERFORMANCE Ag
				33011-3003	LEFT (D)		1.50-2.00mm <sup>2</sup>					
				33011-2002	RIGHT (B)	18	20/18/16AWG	3.3	3.1	1.3	1.4	
				33011-3002	LEFT (D)		0.75-1.00mm <sup>2</sup>					
				33011-2001	RIGHT (B)	22	22AWG	2.5	2.6	0.9	1.0	
33011-3001	LEFT (D)											
33011-2004	RIGHT (B)	M3		0.35-0.50mm <sup>2</sup>	2.5	2.7	0.9	1.54 ±0.1				
33011-3004	LEFT (D)											

\* REFERENCE AS-33000-001 FOR SPECIFIC WIRE TYPES

<b>ENTER DESCRIPTION</b> EC NO: UAU2017-1076 DRWINWENKATESH/2017/05/24 CHKDA, DHIR 2017/05/29 APPR: T.JSM/TH 2017/06/09 D1	QUALITY SYMBOLS 	GENERAL TOLERANCES (UNLESS SPECIFIED)		DIMENSION STYLE <b>MM ONLY</b>	SCALE	DESIGN UNITS <b>METRIC</b>	THIRD ANGLE PROJECTION		
		4 PLACES ± --- ± ---	3 PLACES ± --- ± ---	2 PLACES ± 0.10 ± ---	1 PLACE ± 0.3 ± ---	0 PLACE ± ±	DRAWN BY DATE L.PULLIAM 2006/01/31		
		ANGULAR ± 3 °					CHECKED BY DATE A.DHIR 2006/02/01		
		DRAFT WHERE APPLICABLE MUST REMAIN WITHIN DIMENSIONS					APPROVED BY DATE B.MOSER 2006/02/02		
							MATERIAL NO. DOCUMENT NO. SHEET NO. <b>SEE TABLE</b> SD-33000-001 2 OF 5		

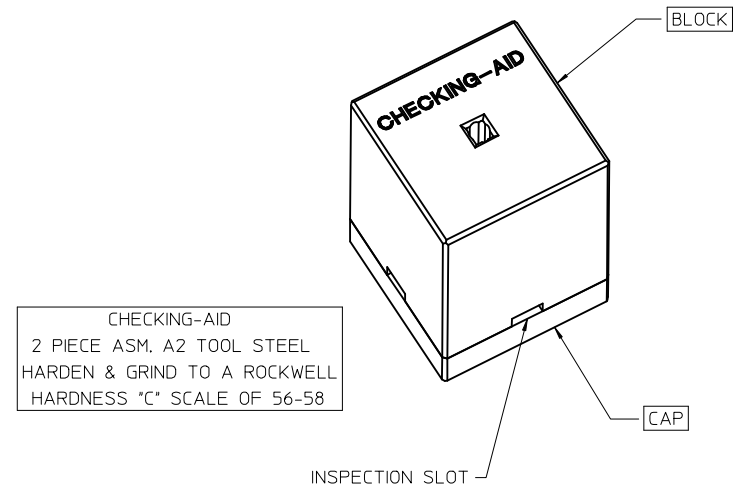
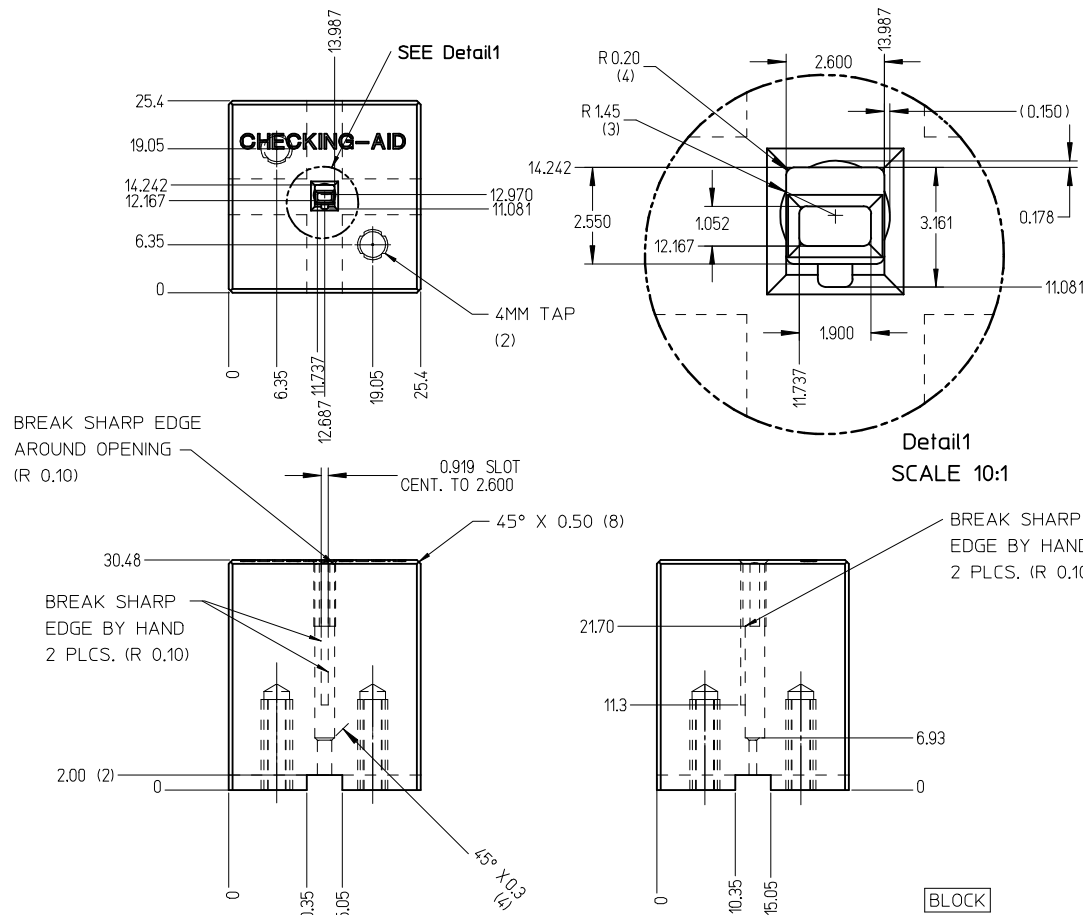

CHECKING-AID  
 2 PIECE ASM. A2 TOOL STEEL  
 HARDEN & GRIND TO A ROCKWELL  
 HARDNESS "C" SCALE OF 56-58

CHECKING AID TOLERANCE  
 .XXX = .005  
 .XX = .03  
 .X = .3

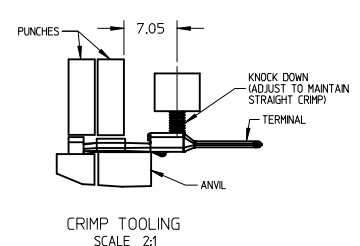
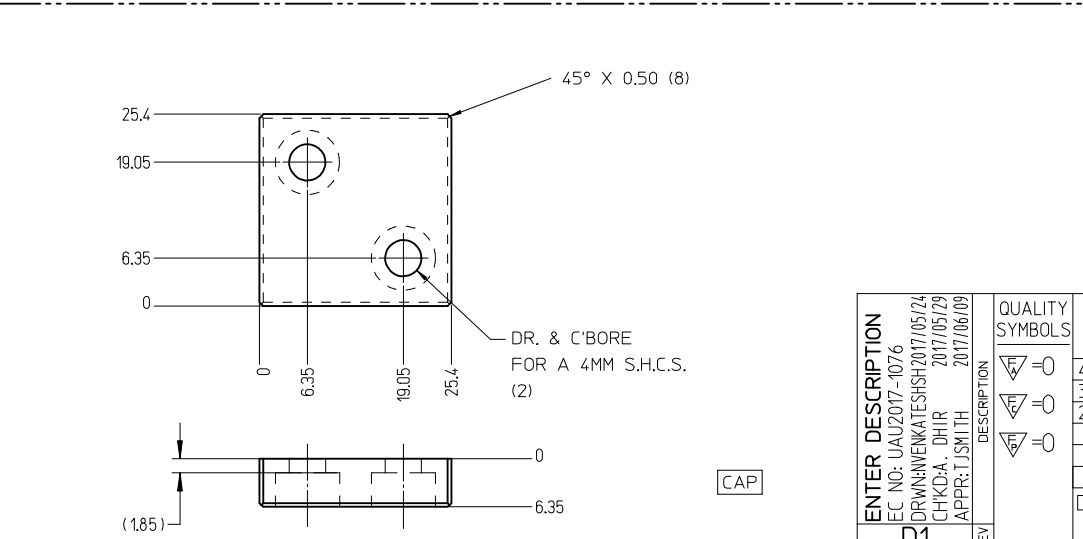

- CRIMP REQUIREMENTS:
1. CRIMP STRAIGHTNESS MUST BE MAINTAINED. USE A KNOCKDOWN TOOL LOCATED AS SHOWN. TERMINAL BOX MUST NOT BE DEFORMED
  2. AFTER CRIMPING, THE TERMINAL AND WIRE MUST FIT FREELY INTO THE CHECKING AID 33000-700. PROPER INSERTION DEPTH IS MET WHEN BLADE TIP STOPS ON CAP. SLOTS PROVIDED TO VISUALLY INSPECT STOPPAGE OF PIN TIP.
  3. FOR OTHER MECHANICAL REQUIREMENTS ON CRIMPED TERMINALS. REFER TO SAE/USCAR-21 (5-13-02) SECTIONS 4.2 (VISUAL INSPECTION), 4.3 (CROSS SECTION ANALYSIS) AND 4.4 (CONDUCTOR CRIMP PULLOUT FORCE)

REV	DESCRIPTION	QUALITY SYMBOLS
D1	ENTER DESCRIPTION EC NO: UAU2017-1076 DRWN:VENKATESH2017/05/24 CHKD:A. DHIR 2017/05/29 APPR:TJSM:TH 2017/06/09	▽=0 ▽=0 ▽=0

GENERAL TOLERANCES (UNLESS SPECIFIED)	
	mm INCH
4 PLACES ±	±
3 PLACES ±	±
2 PLACES ±	±0.10
1 PLACE ±	±0.3
0 PLACE ±	±
ANGULAR ± 3 °	
DRAFT WHERE APPLICABLE MUST REMAIN WITHIN DIMENSIONS	

DIMENSION STYLE MM ONLY	
DRAWN BY	DATE
L.PULLIAM	2006/01/31
CHECKED BY	DATE
A.DHIR	2006/02/01
APPROVED BY	DATE
B.MOSER	2006/02/02
MATERIAL NO.	
SEE TABLE	
SIZE	C

SCALE	2:1	DESIGN UNITS	METRIC	THIRD ANGLE PROJECTION
MX150 1.5MM BLADE TERMINAL				
molex				SHEET NO.
DOCUMENT NO. SD-33000-001				3 OF 5
THIS DRAWING CONTAINS INFORMATION THAT IS PROPRIETARY TO MOLEX INCORPORATED AND SHOULD NOT BE USED WITHOUT WRITTEN PERMISSION				

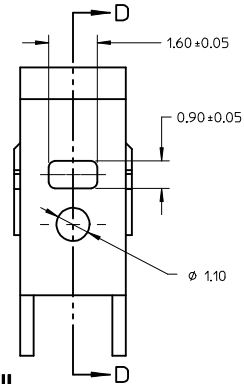
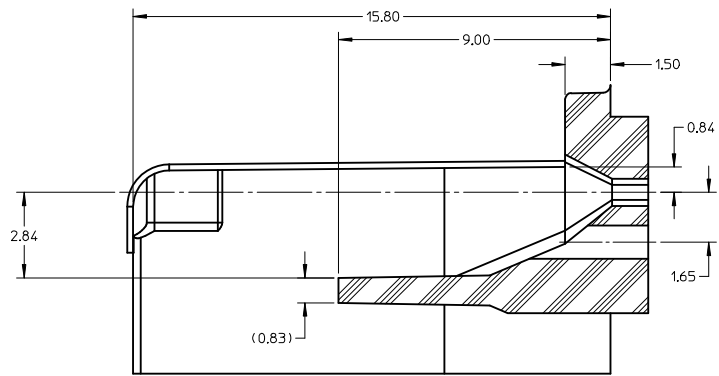
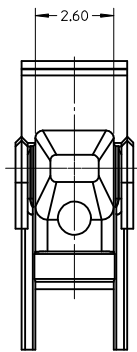

SECTION D-D TPA/INSERT DETAIL

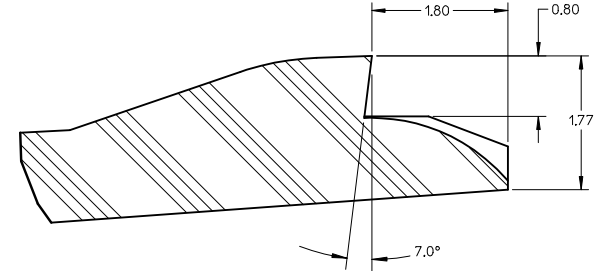
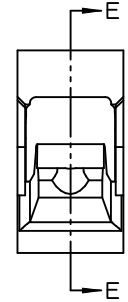
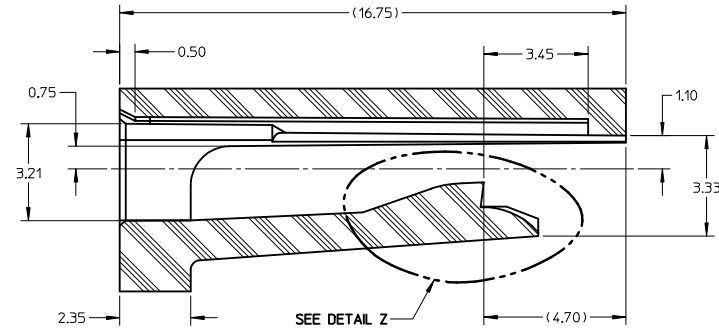
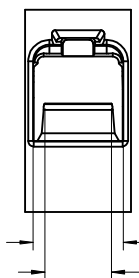

DETAIL Z SCALE 20:1

HOUSING DETAIL

- NOTES: (UNLESS OTHERWISE SPECIFIED)
- TOLERANCES: LINEAR +0.10  
ANGULAR 3°
  - ALL DRAFT WITHIN TOLERANCE
  - MAX RADI ON ALL CORNERS SHOWN SHARP: 0.10
  - MAX FLASH PERMISSIBLE: 0.1
  - EJECTOR PIN MARKS PERMISSIBLE IF FLUSH TO 0.25 BELOW SURFACE
  - MATERIAL: HOUSING/FINGER SPECIFICATION ENGINEERED FOR MATERIAL WITH THE FOLLOWING PROPERTIES:  
A. FLEXURAL MODULUS = 4,500 TO 9,400 MPa  
PER ASTM TEST D790  
B. ELONGATION AT YIELD = 2.3% OR BETTER  
PER ASTM TEST D638 TYPE V
  - CAVITY SPEC FOR USE ONLY WITH MOLEX BLADE TERMINAL PART NUMBERS (EXCEPT P/N'S FOR UNSEALED APPLICATIONS) SPECIFIED ELSEWHERE ON THIS DRAWING

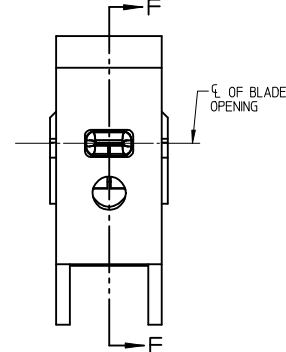
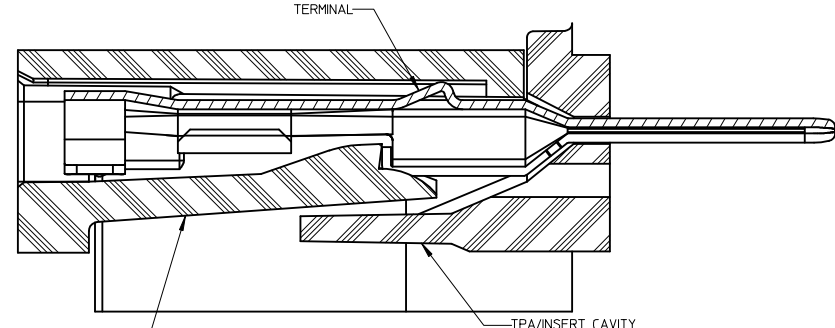
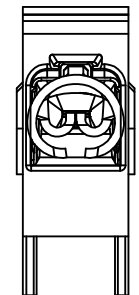

SECTION F-F

BLADE CAVITY ASSEMBLY VIEWS

REV	DESCRIPTION	QUALITY SYMBOLS
D1	ENTER DESCRIPTION EC NO: UAU2017-1076 DRWINVENKATESHSH2017/05/24 CHKD:A. DHIR 2017/05/29 APPR:TJSMITH 2017/06/09	▽=0 ▽=0 ▽=0

GENERAL TOLERANCES (UNLESS SPECIFIED)	
mm	INCH
4 PLACES ± .05	± .002
3 PLACES ± .03	± .001
2 PLACES ± 0.10	± .004
1 PLACE ± 0.3	± .012
0 PLACE ±	±
ANGULAR ± 3°	
DRAFT WHERE APPLICABLE MUST REMAIN WITHIN DIMENSIONS	

DIMENSION STYLE	
MM ONLY	
DRAWN BY	DATE
L.PULLIAM	2006/01/31
CHECKED BY	DATE
A.DHIR	2006/02/01
APPROVED BY	DATE
B.MOSER	2006/02/02
MATERIAL NO.	
SEE TABLE	

SCALE	DESIGN UNITS	THIRD ANGLE PROJECTION
	METRIC	
TITLE		
MX150 15MM BLADE TERMINAL		
DOCUMENT NO.		SHEET NO.
SD-33000-001		4 OF 5
THIS DRAWING CONTAINS INFORMATION THAT IS PROPRIETARY TO MOLEX INCORPORATED AND SHOULD NOT BE USED WITHOUT WRITTEN PERMISSION		

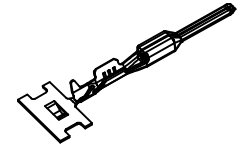

ISO VIEW  
SCALE 2:1

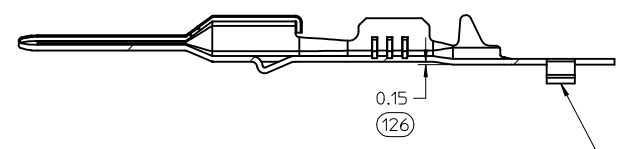
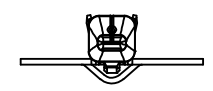
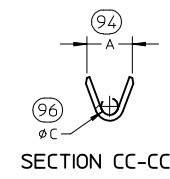
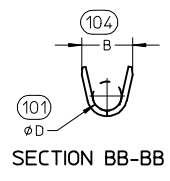
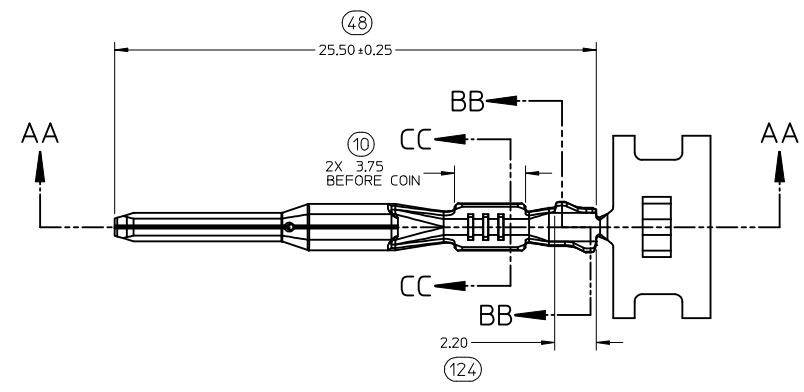

SECTION AA-AA  
M3 GRIP CODE TERMINAL  
SEE TABLE (SHEET 2) FOR PART NUMBERS

CARRIER BUMP DIRECTION  
POINTS DOWN FOR TIN PLATED TERMINALS  
POINTS UP FOR PRECIOUS METAL PLATED  
TERMINALS

<b>ENTER DESCRIPTION</b> EC NO: UAU2017-1076 DRW: NVENKATESHSH/2017/05/24 CHKD: A. DHIR 2017/05/29 APPR: T.JSMITH 2017/06/09	<b>QUALITY SYMBOLS</b> ▽=0 ▽=0 ▽=0	<b>GENERAL TOLERANCES (UNLESS SPECIFIED)</b>		<b>DIMENSION STYLE</b> MM ONLY	<b>SCALE</b> 5:1	<b>DESIGN UNITS</b> METRIC	THIRD ANGLE PROJECTION		
		4 PLACES ± --- ± --- 3 PLACES ± --- ± --- 2 PLACES ± 0.10 ± --- 1 PLACE ± 0.3 ± ---	mm INCH	DRAWN BY DATE L.PULLIAM 2006/01/31	CHECKED BY DATE A.DHIR 2006/02/01	<b>TITLE</b> MX150 15MM BLADE TERMINAL			
		ANGULAR ± 3°		APPROVED BY DATE B.MOSER 2006/02/02	MOLEX INCORPORATED				
		DRAFT WHERE APPLICABLE MUST REMAIN WITHIN DIMENSIONS		MATERIAL NO. SEE TABLE	DOCUMENT NO. SD-33000-001	SHEET NO. 5 OF 5			

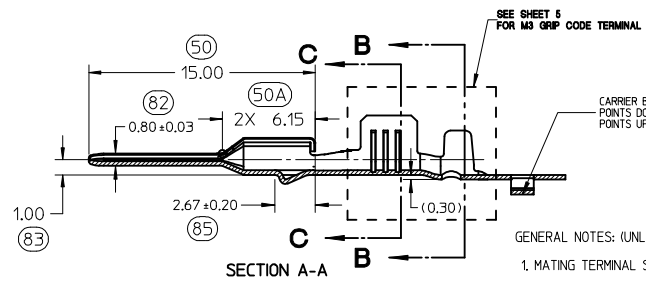
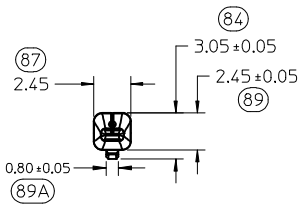
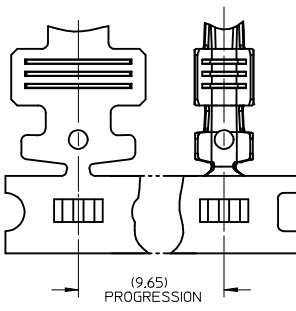
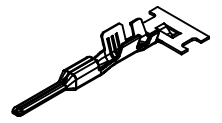
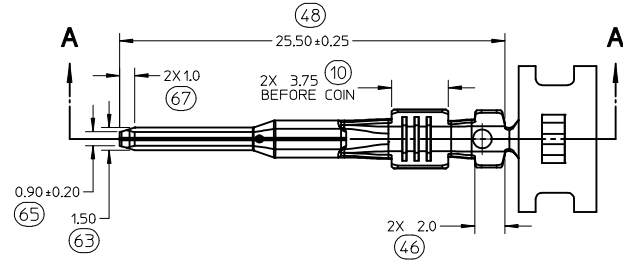
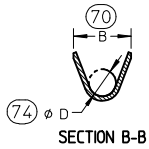
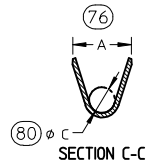

- GENERAL NOTES: (UNLESS OTHERWISE SPECIFIED)
- MATING TERMINAL SHOWN ON SD-33012-002
  - MATERIAL: ASTM B422, UNS C19025, HR04  
THICKNESS: 0.30 mm +0.01  
TEMPER: FULL HARD (REF)  
TENSILE: 496-572 MPA
  - TIN PLATED TERMINAL FINISH:  
OVERALL UNDERPLATE ELECTRODEPOSITED NICKEL  
OVERALL ELECTRODEPOSITED REFLOW TIN
  - GOLD PLATED TERMINAL FINISH:  
OVERALL UNDERPLATE ELECTRODEPOSITED DUCTILE SULFAMATE NICKEL  
CONTACT AREA - ELECTRODEPOSITED GOLD  
GRIP AREA - ELECTRODEPOSITED 100% TIN MATTE FINISH
  - SILVER PLATED TERMINAL FINISH:  
OVERALL UNDERPLATE ELECTRODEPOSITED DUCTILE SULFAMATE NICKEL  
CONTACT AREA - ELECTRODEPOSITED PURE SILVER (0.5% MAX IMPURITIES) SEMI-BRIGHT FINISH  
- SILVER ANTI-TARNISH - EVABRITE  
GRIP AREA - ELECTRODEPOSITED 100% TIN MATTE FINISH
  - MEETS CRIMP PERFORMANCE SPECIFICATION SAE/USCAR-21 (8/2001)
  - MEETS PERFORMANCE STANDARD FOR AUTOMOTIVE ELECTRICAL CONNECTOR SYSTEMS  
SAE/USCAR-2 REV 3 (APRIL 2001)
  - MEETS FIELD CORRELATED LIFE TEST SAE/USCAR-20 (11/2001)
  - MEETS WIRING COMPONENT DESIGN GUIDELINES SAE/USCAR-12 REV 2 (12/2001)
  - MEETS ELECTRICAL CONNECTION SYSTEM DESIGN SPECIFICATION (SDS) REV 11 (5/2002)
  - REFERENCE PK-31300-516 FOR REEL DIRECTION
  - REFERENCE AS-33000-001 FOR CRIMP INFORMATION

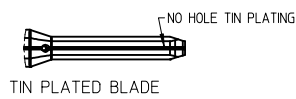
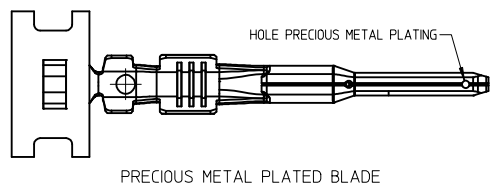

ENTER DESCRIPTION EC NO: UAU2017-1076 DRWINWENKATESHSH2017/05/24 CHKD:A. DHIR 2017/05/29 APPR:TJSMITH 2017/06/09	QUALITY SYMBOLS ▽=0 ▽=0 ▽=0	GENERAL TOLERANCES (UNLESS SPECIFIED)		DIMENSION STYLE MM ONLY		SCALE 4:1	DESIGN UNITS METRIC	THIRD ANGLE PROJECTION	
		mm	INCH	DRAWN BY L.PULLIAM	DATE 2006/01/31	TITLE MX150 15MM BLADE TERMINAL			
D1	DESCRIPTION	4 PLACES ±	±	CHECKED BY A.DHIR	DATE 2006/02/01	DOCUMENT NO. SD-33000-001			
		3 PLACES ±	±	APPROVED BY B.MOSER	DATE 2006/02/02				
		2 PLACES ±	± 0.10	MATERIAL NO. SEE TABLE		SHEET NO. 1 OF 5			
		1 PLACE ±	± 0.3	DRAFT WHERE APPLICABLE MUST REMAIN WITHIN DIMENSIONS		THIS DRAWING CONTAINS INFORMATION THAT IS PROPRIETARY TO MOLEX INCORPORATED AND SHOULD NOT BE USED WITHOUT WRITTEN PERMISSION			
		0 PLACE ±	±	ANGULAR ± 3 °					

FAMILY	GENDER	SEALING	PLATING	PART NUMBER	PAYOFF DIRECTION	GRIP CODE	WIRE SIZES*	A ±0.30	B ±0.30	C ±0.30	D ±0.30	SPECIAL CHARACTERISTICS
MX150	BLADE	MAT SEAL UNSEALED	Sn	33000-0001	RIGHT (B)	14	14AWG	3.9	3.8	1.7	1.6	HIGH PERFORMANCE Sn
				33000-1001	LEFT (D)		1.50-2.00mm <sup>2</sup>					
				33000-0002	RIGHT (B)	18	20/18/16AWG	3.3	3.1	1.3	1.4	
				33000-1002	LEFT (D)		0.75-1.00mm <sup>2</sup>					
				33000-0003	RIGHT (B)	22	22AWG	2.5	2.6	0.9	1.0	
				33000-1003	LEFT (D)							
				33000-0004	RIGHT (B)	M3	0.35-0.50mm <sup>2</sup>	2.5	2.7	0.9	1.54 ±0.1	
			33000-1004	LEFT (D)								
			Au	33011-1002	RIGHT (B)	14	14AWG	3.9	3.8	1.7	1.6	HIGH PERFORMANCE Au
				33011-0002	LEFT (D)		1.50-2.00mm <sup>2</sup>					
				33011-1004	RIGHT (B)	18	20/18/16AWG	3.3	3.1	1.3	1.4	
				33011-0004	LEFT (D)		0.75-1.00mm <sup>2</sup>					
				33011-1006	RIGHT (B)	22	22AWG	2.5	2.6	0.9	1.0	
				33011-0006	LEFT (D)							
				33011-1008	RIGHT (B)	M3	0.35-0.50mm <sup>2</sup>	2.5	2.7	0.9	1.54 ±0.1	
			33011-0008	LEFT (D)								
			Ag	33011-2003	RIGHT (B)	14	14AWG	3.9	3.8	1.7	1.6	HIGH PERFORMANCE Ag
				33011-3003	LEFT (D)		1.50-2.00mm <sup>2</sup>					
				33011-2002	RIGHT (B)	18	20/18/16AWG	3.3	3.1	1.3	1.4	
				33011-3002	LEFT (D)		0.75-1.00mm <sup>2</sup>					
				33011-2001	RIGHT (B)	22	22AWG	2.5	2.6	0.9	1.0	
33011-3001	LEFT (D)											
33011-2004	RIGHT (B)	M3		0.35-0.50mm <sup>2</sup>	2.5	2.7	0.9	1.54 ±0.1				
33011-3004	LEFT (D)											

\* REFERENCE AS-33000-001 FOR SPECIFIC WIRE TYPES

<b>ENTER DESCRIPTION</b> EC NO: UAU2017-1076 DRW: NANKATESH/2017/05/24 CHK: D.A. DHIR 2017/05/29 APPR: T.JSM/TH 2017/06/09	QUALITY SYMBOLS ▽=0 ▽=0 ▽=0	GENERAL TOLERANCES (UNLESS SPECIFIED)		DIMENSION STYLE <b>MM ONLY</b>	SCALE DESIGN UNITS <b>METRIC</b>	THIRD ANGLE PROJECTION
		4 PLACES ± --- ± --- 3 PLACES ± --- ± --- 2 PLACES ± 0.10 ± --- 1 PLACE ± 0.3 ± --- 0 PLACE ± ±	mm INCH	DRAWN BY DATE L.PULLIAM 2006/01/31	TITLE MX150 15MM BLADE TERMINAL	
		ANGULAR ± 3 °		CHECKED BY DATE A.DHIR 2006/02/01	<b>molex</b>	
		DRAFT WHERE APPLICABLE MUST REMAIN WITHIN DIMENSIONS		APPROVED BY DATE B.MOSER 2006/02/02		
		MATERIAL NO.		DOCUMENT NO.		
D1	SEE TABLE	SD-33000-001	SHEET NO. 2 OF 5			

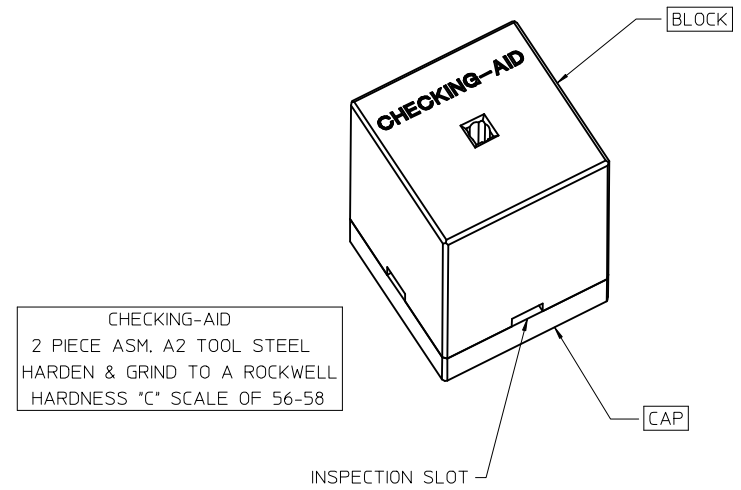
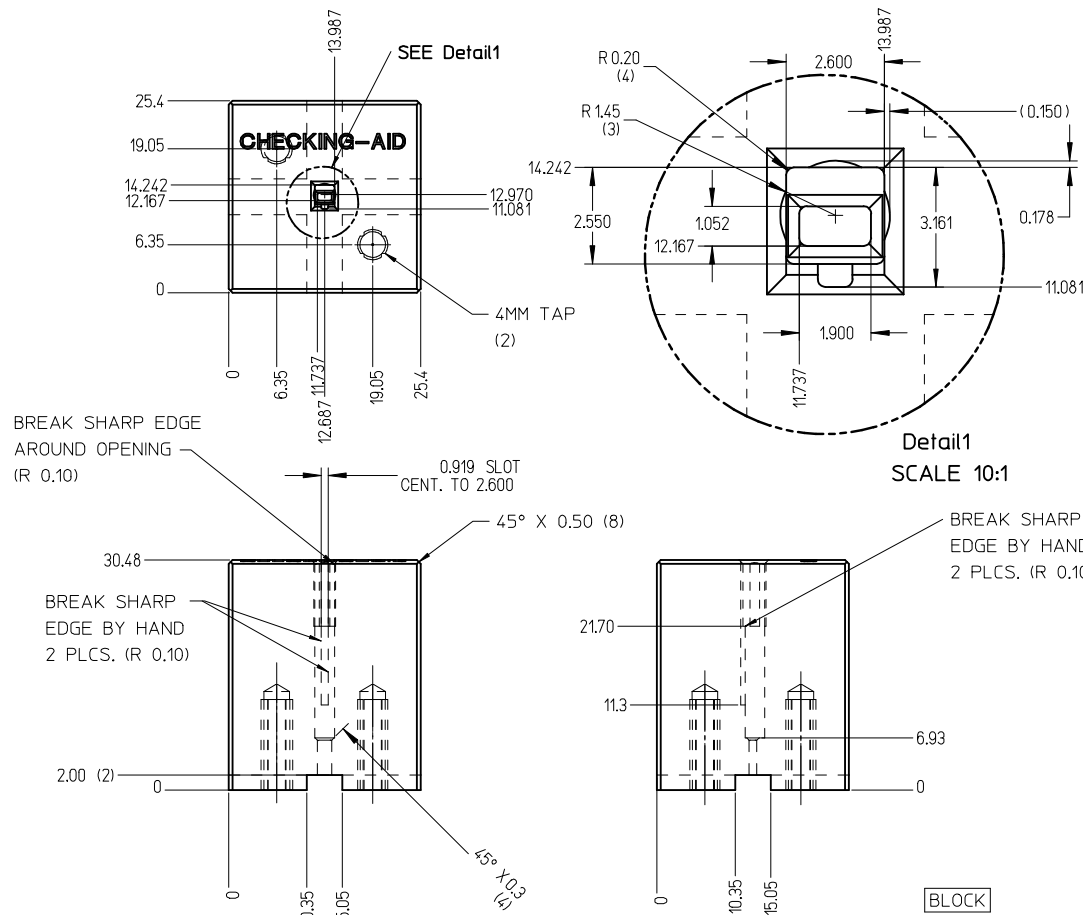

CHECKING-AID  
 2 PIECE ASM. A2 TOOL STEEL  
 HARDEN & GRIND TO A ROCKWELL  
 HARDNESS "C" SCALE OF 56-58

CHECKING AID TOLERANCE  
 .XXX = .005  
 .XX = .03  
 .X = .3

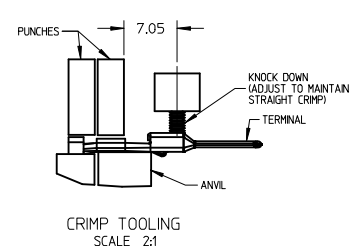
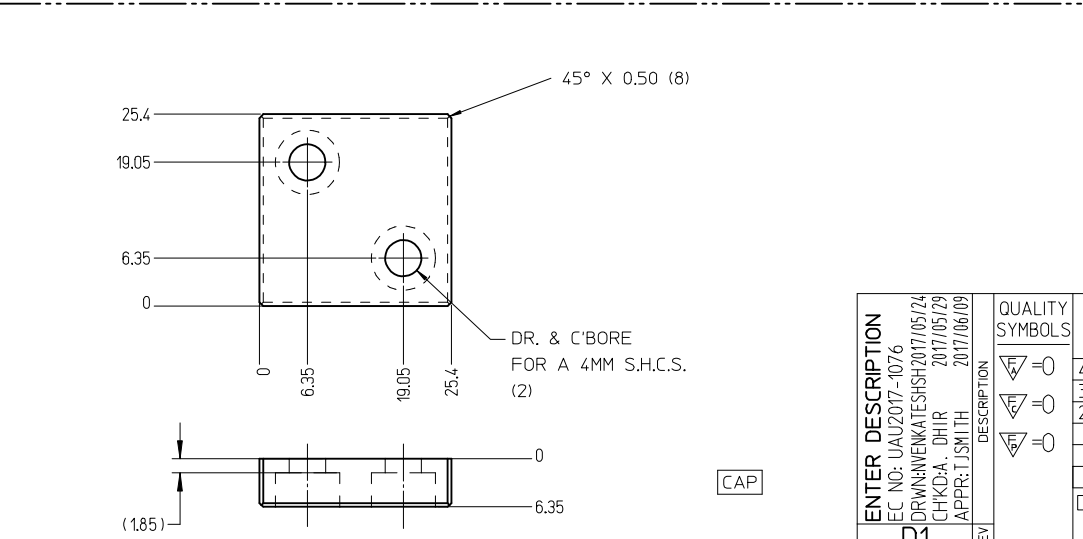

- CRIMP REQUIREMENTS:
1. CRIMP STRAIGHTNESS MUST BE MAINTAINED. USE A KNOCKDOWN TOOL LOCATED AS SHOWN. TERMINAL BOX MUST NOT BE DEFORMED
  2. AFTER CRIMPING, THE TERMINAL AND WIRE MUST FIT FREELY INTO THE CHECKING AID 33000-700. PROPER INSERTION DEPTH IS MET WHEN BLADE TIP STOPS ON CAP. SLOTS PROVIDED TO VISUALLY INSPECT STOPPAGE OF PIN TIP.
  3. FOR OTHER MECHANICAL REQUIREMENTS ON CRIMPED TERMINALS, REFER TO SAE/USCAR-21 (5-13-02) SECTIONS 4.2 (VISUAL INSPECTION), 4.3 (CROSS SECTION ANALYSIS) AND 4.4 (CONDUCTOR CRIMP PULLOUT FORCE)

ENTER DESCRIPTION EC NO: UAU2017-1076 DRWN:VENKATESH2017/05/24 CHKD:A. DHIR 2017/05/29 APPR:TJSM/TH 2017/06/09	QUALITY SYMBOLS ▽=0 ▽=0 ▽=0	GENERAL TOLERANCES (UNLESS SPECIFIED)		DIMENSION STYLE <b>MM ONLY</b>		SCALE <b>2:1</b>	DESIGN UNITS <b>METRIC</b>	THIRD ANGLE PROJECTION	
		4 PLACES ± --- ± --- 3 PLACES ± --- ± --- 2 PLACES ± 0.10 ± --- 1 PLACE ± 0.3 ± --- 0 PLACE ± ±	mm INCH ± --- ± --- ± --- ± --- ± --- ± --- ± --- ± --- ± ±	DRAWN BY L.PULLIAM	DATE 2006/01/31	CHECKED BY A.DHIR	DATE 2006/02/01	APPROVED BY B.MOSER	DATE 2006/02/02
DRAFT WHERE APPLICABLE MUST REMAIN WITHIN DIMENSIONS	ANGULAR ± 3 °	MATERIAL NO. <b>SEE TABLE</b>		DOCUMENT NO. <b>SD-33000-001</b>		<b>molex</b>		SHEET NO. <b>3 OF 5</b>	



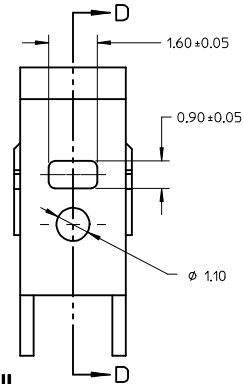
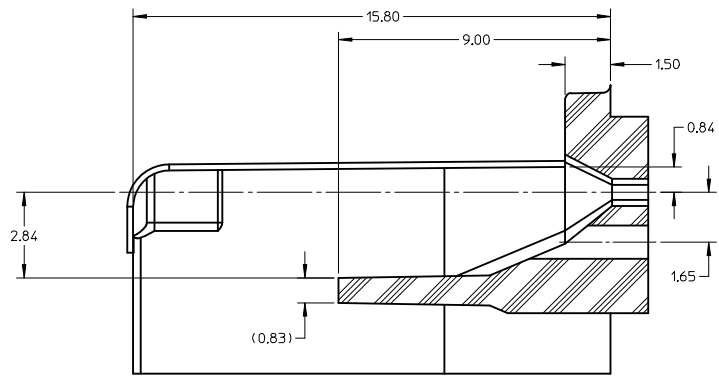
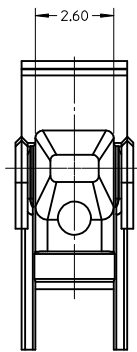

SECTION D-D  
TPA/INSERT DETAIL

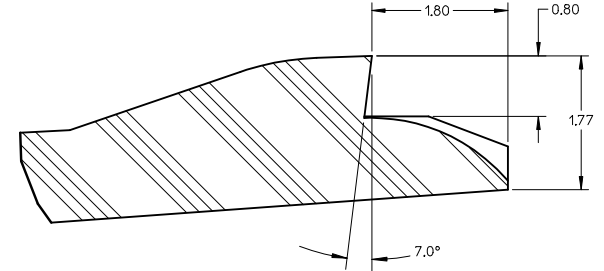
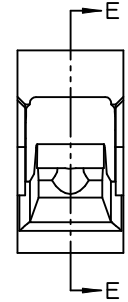
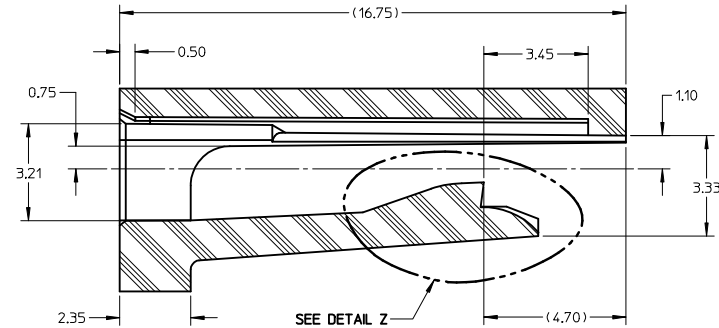
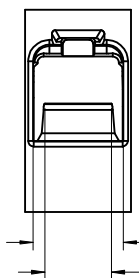

DETAIL Z  
SCALE 20:1

HOUSING DETAIL

- NOTES: (UNLESS OTHERWISE SPECIFIED)
- TOLERANCES: LINEAR +0.10  
ANGULAR 3°
  - ALL DRAFT WITHIN TOLERANCE
  - MAX RADII ON ALL CORNERS SHOWN SHARP: 0.10
  - MAX FLASH PERMISSIBLE: 0.1
  - EJECTOR PIN MARKS PERMISSIBLE IF FLUSH TO 0.25 BELOW SURFACE
  - MATERIAL: HOUSING/FINGER SPECIFICATION ENGINEERED FOR MATERIAL WITH THE FOLLOWING PROPERTIES:  
A. FLEXURAL MODULUS = 4,500 TO 9,400 MPa  
PER ASTM TEST D790  
B. ELONGATION AT YIELD = 2.3% OR BETTER  
PER ASTM TEST D638 TYPE V
  - CAVITY SPEC FOR USE ONLY WITH MOLEX BLADE TERMINAL PART NUMBERS (EXCEPT P/N'S FOR UNSEALED APPLICATIONS) SPECIFIED ELSEWHERE ON THIS DRAWING

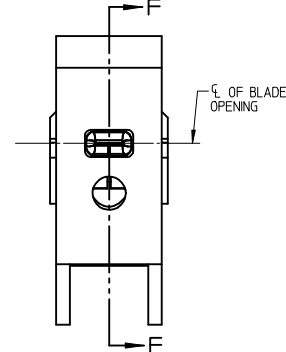
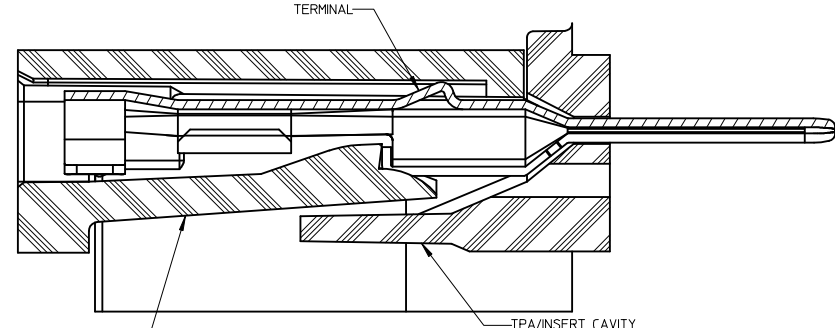
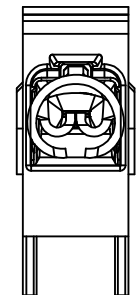

SECTION F-F  
BLADE CAVITY ASSEMBLY VIEWS

BLADE CAVITY ASSEMBLY VIEWS

REV	DESCRIPTION	QUALITY SYMBOLS
D1	ENTER DESCRIPTION EC NO: UAU2017-1076 DRW:WENKATESH2017/05/24 CHKD:A. DHIR 2017/05/29 APPR:TJSMITH 2017/06/09	▽=0 ▽=0 ▽=0

GENERAL TOLERANCES (UNLESS SPECIFIED)	
mm	INCH
4 PLACES ± ---	± ---
3 PLACES ± ---	± ---
2 PLACES ± 0.10	± ---
1 PLACE ± 0.3	± ---
0 PLACE ±	±
ANGULAR ± 3 °	
DRAFT WHERE APPLICABLE MUST REMAIN WITHIN DIMENSIONS	

DIMENSION STYLE	
MM ONLY	
DRAWN BY	DATE
L.PULLIAM	2006/01/31
CHECKED BY	DATE
A.DHIR	2006/02/01
APPROVED BY	DATE
B.MOSER	2006/02/02
MATERIAL NO.	
SEE TABLE	

SCALE	DESIGN UNITS	THIRD ANGLE PROJECTION
	METRIC	
TITLE		
MX150 15MM BLADE TERMINAL		
DOCUMENT NO.		SHEET NO.
SD-33000-001		4 OF 5
THIS DRAWING CONTAINS INFORMATION THAT IS PROPRIETARY TO MOLEX INCORPORATED AND SHOULD NOT BE USED WITHOUT WRITTEN PERMISSION		

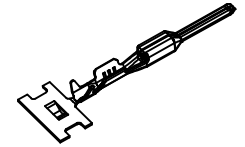

ISO VIEW  
SCALE 2:1

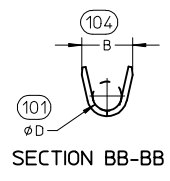
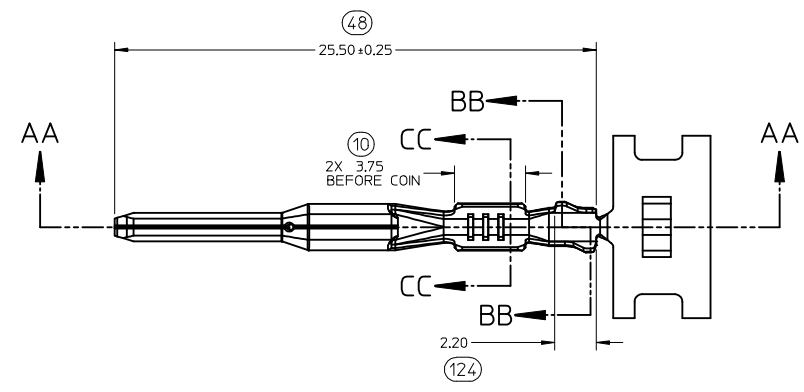

SECTION BB-BB

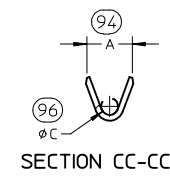

SECTION CC-CC

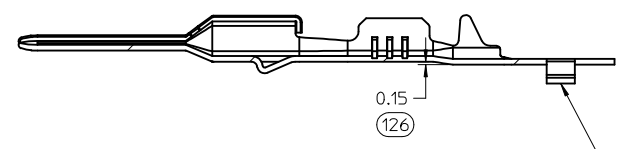
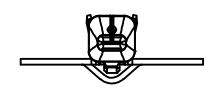

SECTION AA-AA  
M3 GRIP CODE TERMINAL  
SEE TABLE (SHEET 2) FOR PART NUMBERS

CARRIER BUMP DIRECTION  
POINTS DOWN FOR TIN PLATED TERMINALS  
POINTS UP FOR PRECIOUS METAL PLATED TERMINALS

<b>ENTER DESCRIPTION</b> EC NO: UAU2017-1076 DRW: NVENKATESHSH/2017/05/24 CHKD: A. DHIR 2017/05/29 APPR: T.JSMITH 2017/06/09 REV: D1	QUALITY SYMBOLS ▽=0 ▽=0 ▽=0	GENERAL TOLERANCES (UNLESS SPECIFIED) <table border="1"> <tr> <th></th> <th>mm</th> <th>INCH</th> </tr> <tr> <td>4 PLACES</td> <td>± ---</td> <td>± ---</td> </tr> <tr> <td>3 PLACES</td> <td>± ---</td> <td>± ---</td> </tr> <tr> <td>2 PLACES</td> <td>± 0.10</td> <td>± ---</td> </tr> <tr> <td>1 PLACE</td> <td>± 0.3</td> <td>± ---</td> </tr> </table> ANGULAR ± 3°		mm	INCH	4 PLACES	± ---	± ---	3 PLACES	± ---	± ---	2 PLACES	± 0.10	± ---	1 PLACE	± 0.3	± ---	DIMENSION STYLE <b>MM ONLY</b> DRAWN BY DATE L.PULLIAM 2006/01/31 CHECKED BY DATE A.DHIR 2006/02/01 APPROVED BY DATE B.MOSER 2006/02/02	SCALE <b>5:1</b>	DESIGN UNITS <b>METRIC</b>	THIRD ANGLE PROJECTION
		mm	INCH																		
	4 PLACES	± ---	± ---																		
	3 PLACES	± ---	± ---																		
2 PLACES	± 0.10	± ---																			
1 PLACE	± 0.3	± ---																			
TITLE <b>MX150 15MM BLADE TERMINAL</b>																					
MATERIAL NO. <b>SEE TABLE</b>																					
DRAFT WHERE APPLICABLE MUST REMAIN WITHIN DIMENSIONS																					

**MOLEX INCORPORATED**  
 DOCUMENT NO. **SD-33000-001** SHEET NO. **5 OF 5**  
 THIS DRAWING CONTAINS INFORMATION THAT IS PROPRIETARY TO MOLEX INCORPORATED AND SHOULD NOT BE USED WITHOUT WRITTEN PERMISSION