

**SPECIFICATION**  
**FOR**  
**LCM Module**

MODULE No:	KD050FWFLD099
CUSTOMER:	

STARTEK	INITIAL	DATE
PREPARED BY		
CHECKED BY		
APPROVED BY		

CUSTOMER	INITIAL	DATE
APPROVED BY		

Part. No	KD050FWFLD099	REV	V1.0	Page 1 of 26
----------	---------------	-----	------	--------------

常备库存  
Stock For Sale

长期供货  
Long Time supply

支持小量  
NO MOQ

品种齐全  
In Full Range



## Contents

<b>1. Block Diagram</b> .....	<b>5</b>
<b>2. Outline dimension</b> .....	<b>6</b>
<b>3. Input terminal Pin Assignment</b> .....	<b>7</b>
<b>4. LCD Optical Characteristics</b> .....	<b>9</b>
4.1 Optical specification.....	9
<b>5. Electrical Characteristics</b> .....	<b>12</b>
5.1 Absolute Maximum Rating.....	12
5.2 DC Electrical Characteristics.....	12
5.3 LED Backlight Characteristics.....	13
<b>6. LVDS Signal Timing Characteristics</b> .....	<b>15</b>
6.1 AC Electrical Characteristics.....	15
6.2 Timing Table.....	16
6.3 LVDS Data Input Format.....	17
<b>7. LCD Module Out-Going Quality Level</b> .....	<b>18</b>
<b>7.1 VISUAL &amp; FUNCTION INSPECTION STANDARD</b> .....	<b>18</b>
7.1.1 Inspection conditions.....	18
7.1.2 Definition.....	18
7.1.3 Sampling Plan.....	19
7.1.4 Criteria (Visual).....	20
<b>8. Reliability Test Result</b> .....	<b>24</b>
<b>9. Cautions and Handling Precautions</b> .....	<b>25</b>
9.1 Handling and Operating the Module.....	25
9.2 Storage and Transportation.....	25
<b>10. Packing</b> .....	<b>26</b>

Part. No	KD050FWFLD099	REV	V1.0	Page 3 of 26
	常备库存 Stock For Sale	长期供货 Long Time supply	支持小量 NO MOQ	品种齐全 In Full Range

**\* Description**

This is a color active matrix TFT (Thin Film Transistor) LCD (liquid crystal display) that uses amorphous silicon TFT as a switching device. This module is composed of a Transmissive type TFT-LCD Panel, driver circuit, back-light unit. The resolution of a 5.0 " TFT-LCD contains 480x854 pixels, and can display up to 16.7M colors.

**\* Features**

General Information Items	Specification	Unit	Note
	Main Panel		
Display area(AA)	61.632(H)*109.6536(V) (5.0inch)	mm	
Driver element	TFT active matrix	-	
Display colors	65K/262K/16.7M	colors	
Number of pixels	480(RGB)*854	dots	
Pixel arrangement	RGB vertical stripe	-	
Pixel pitch	0.1284(H)*0.1284(V)	mm	
Viewing angle	ALL	o'clock	
LCM Interface	8BIT LVDS	-	
Display mode	Transmissive /Normally Black	-	
Operating temperature	-20~+70	°C	
Storage temperature	-30~+80	°C	

**\* Mechanical Information**

Item		Min.	Typ.	Max.	Unit	Note
Module size	Horizontal(H)	-	67.06	-	mm	
	Vertical(V)	-	121.85	-	mm	
	Depth(D)	-	2.9	-	mm	
Weight		-	24	-	g	

### 1. Block Diagram

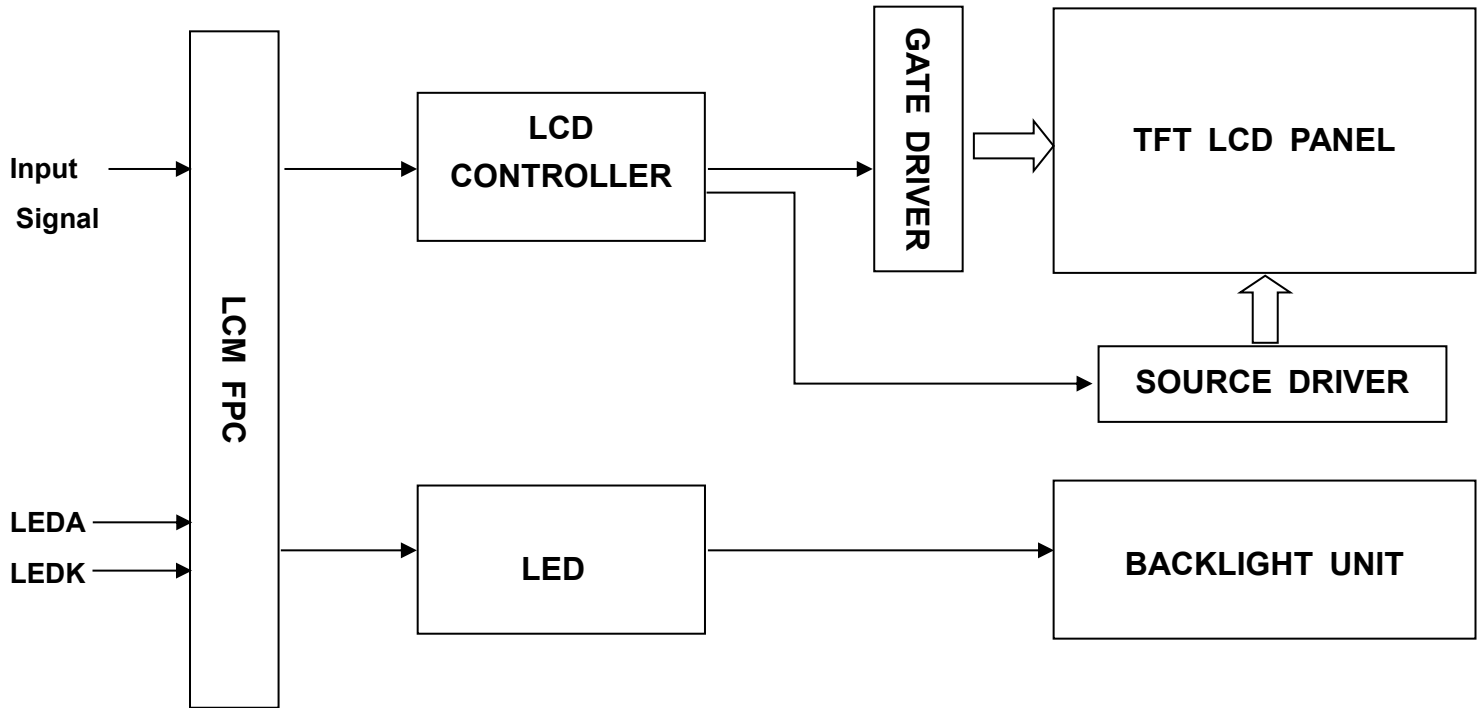

Part. No	KD050FWFLD099	REV	V1.0	Page 5 of 26
常备库存 Stock For Sale	长期供货 Long Time supply	支持小量 NO MOQ	品种齐全 In Full Range	

## 2. Outline dimension

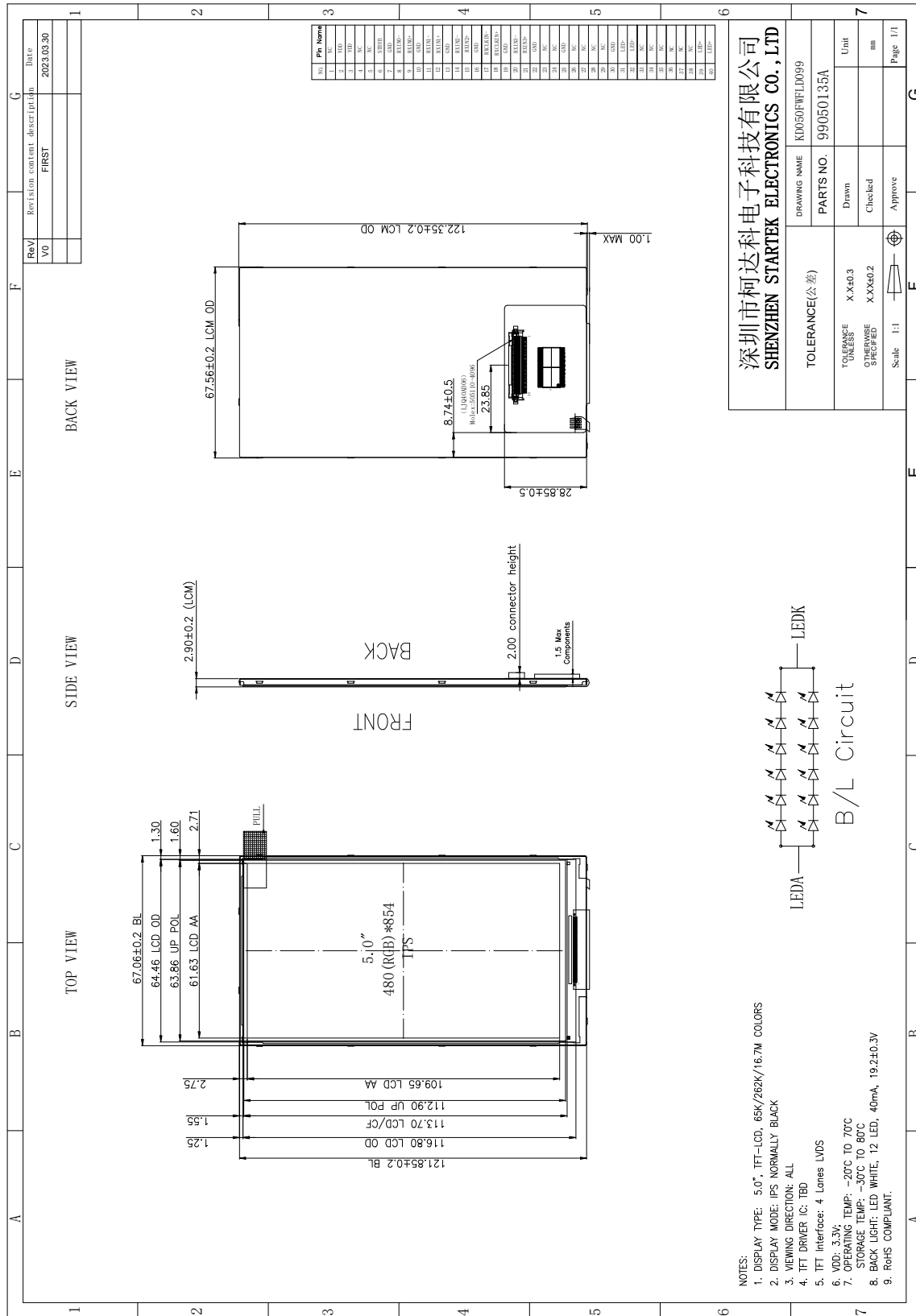

Part. No	KD050FWFLD099	REV	V1.0	Page 6 of 26
----------	---------------	-----	------	--------------

常备库存  
Stock For Sale

长期供货  
Long Time supply

支持小量  
NO MOQ

品种齐全  
In Full Range

### 3. Input terminal Pin Assignment

NO.	SYMBOL	DISCRIPTION	I/O
1	NC	No connected	--
2	VDD	Power supply for digital circuits	P
3	VDD		P
4	NC	No connected	--
5	NC	No connected	--
6	STBYB	Power ON/OFF PIN, Normally pulled high STBYB = "1", Power ON. STBYB = "0", Power OFF.	I
7	GND	Ground	P
8	RXIN0-	- LVDS differential data input	I/O
9	RXIN0+	+ LVDS differential data input	I/O
10	GND	Ground	P
11	RXIN1-	- LVDS differential data input	I/O
12	RXIN1+	+ LVDS differential data input	I/O
13	GND	Ground	P
14	RXIN2-	- LVDS differential data input	I/O
15	RXIN2+	+ LVDS differential data input	I/O
16	GND	Ground	P
17	RXCLKIN-	- LVDS differential clock input	I/O
18	RXCLKIN+	+ LVDS differential clock input	I/O
19	GND	Ground	P
20	RXIN3-	- LVDS differential data input	I/O
21	RXIN3+	+ LVDS differential data input	I/O
22	GND	Ground	P
23	NC	No connected	--
24	NC	No connected	--
25	GND	Ground	P
26	NC	No connected	--
27	NC	No connected	--
28	NC	No connected	--
29	NC	No connected	--
30	GND	Ground	P

Part. No	<b>KD050FWFLD099</b>	REV	V1.0	Page 7 of 26
----------	----------------------	-----	------	--------------

常备库存  
Stock For Sale

长期供货  
Long Time supply

支持小量  
NO MOQ

品种齐全  
In Full Range

31	LED-	LED Cathode	P
32	LED-	LED Cathode	P
33	NC	No connected	--
34	NC	No connected	--
35	NC	No connected	--
36	NC	No connected	--
37	NC	No connected	--
38	NC	No connected	--
39	LED+	LED anode	P
40	LED+	LED anode	P

## 4. LCD Optical Characteristics

### 4.1 Optical specification

Item	Symbol	Condition	Min.	Typ.	Max.	Unit.	Note	
Contrast Ratio	CR	$\Theta=0$ Normal viewing angle	800	1000	--		(1)(2)	
Response time	Rising		$T_{R+T_F}$	--	35	45	msec	(1)(3)
	Falling							
Color Gamut	S(%)			50	61	--	%	
Color Filter Chromaticity	White		$W_X$	-0.04	0.302	+0.04		(1)(4) CA-310
			$W_Y$		0.345			
	Red		$R_X$		0.636			
			$R_Y$		0.356			
	Green		$G_X$		0.321			
			$G_Y$		0.587			
	Blue	$B_X$	0.146					
		$B_Y$	0.090					
Viewing angle	Hor.	$\Theta_L$	--	80	--		(1)(4)	
		$\Theta_R$	--	80	--			
	Ver.	$\Theta_U$	--	80	--			
		$\Theta_D$	--	80	--			
Option View Direction	Free						(5)	

\*The data comes from the LCD specification.

#### Measuring Condition

Measuring surrounding : dark room

Ambient temperature :  $25 \pm 2^\circ\text{C}$

15min. warm-up time.

#### Measuring Equipment

FPM520 of Westar Display technologies, INC., which utilized SR-3 for Chromaticity and BM-5A for other optical characteristics.

Part. No	KD050FWFLD099	REV	V1.0	Page 9 of 26
常备库存 Stock For Sale	长期供货 Long Time supply	支持小量 NO MOQ	品种齐全 In Full Range	

**Note (1):** Definition of Viewing Angle :

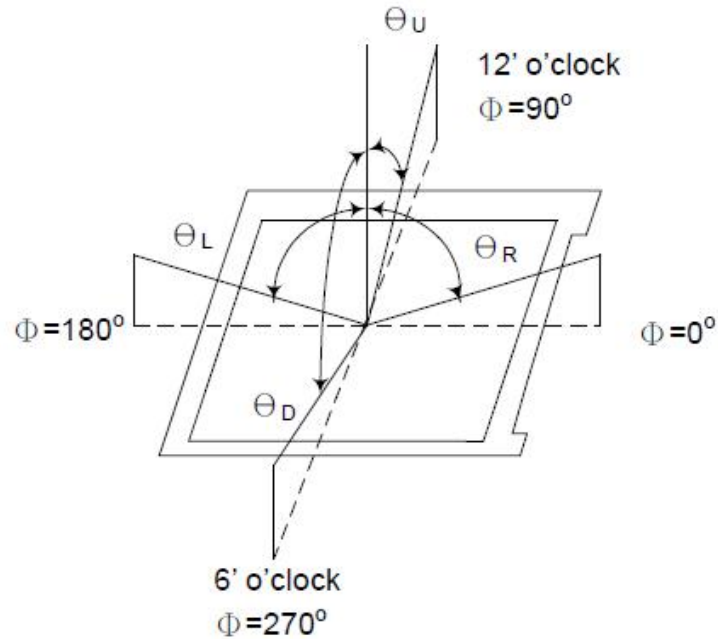

**Note (2):** Definition of Contrast Ratio(CR) :measured at the center point of panel

$$CR = \frac{\text{Luminance with all pixels white}}{\text{Luminance with all pixels black}}$$

**Note (3):** Response Time

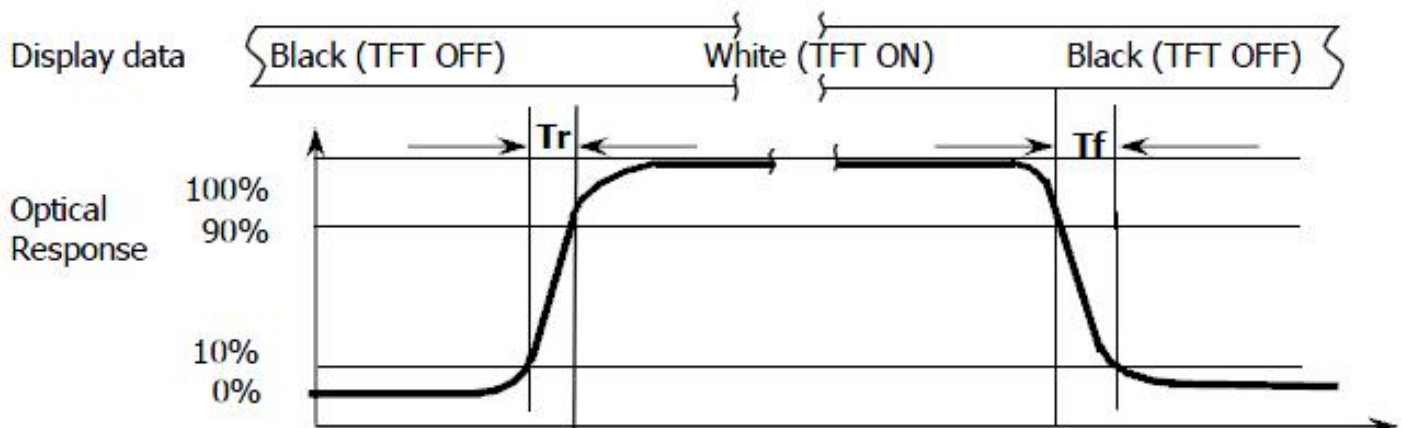

Part. No	KD050FWFLD099	REV	V1.0	Page 10 of 26
常备库存 Stock For Sale	长期供货 Long Time supply	支持小量 NO MOQ	品种齐全 In Full Range	

**Note (4):** Definition of optical measurement setup

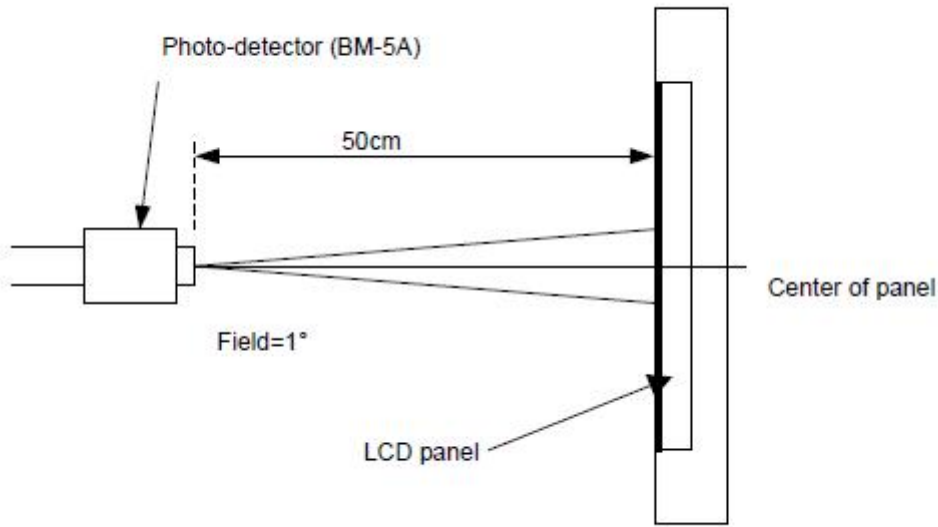

Part. No	KD050FWFLD099	REV	V1.0	Page 11 of 26
常备库存 Stock For Sale	长期供货 Long Time supply	支持小量 NO MOQ	品种齐全 In Full Range	

## 5. Electrical Characteristics

### 5.1 Absolute Maximum Rating

Characteristics	Symbol	Min.	Max.	Unit	Note
Digital Supply Voltage	VDD	-0.3	4.6	V	Note1
Operating temperature	T <sub>OP</sub>	-20	+70	°C	
Storage temperature	T <sub>ST</sub>	-30	+80	°C	

NOTE1: If the absolute maximum rating of even is one of the above parameters is exceeded even momentarily, the quality of the product may be degraded. Absolute maximum ratings, therefore, specify the values exceeding which the product may be physically damaged. Be sure to use the product within the range of the absolute maximum ratings.

### 5.2 DC Electrical Characteristics

Characteristics		Symbol	Min.	Typ.	Max.	Unit	Note
Digital Supply Voltage		VDD	3.0	3.3	3.6	V	
Normal mode Current		IDD	--	35	70	mA	
LVDS Interface	Differential Input High Threshold Voltage	VLVTH	--	--	100	mV	
	Differential Input Low Threshold Voltage	VLVTL	-100	--	--	mV	
RGB Interface		V <sub>IH</sub>	0.7*VDD	--	VDD	V	
Level input voltage		V <sub>IL</sub>	GND	--	0.3* VDD	V	

Part. No	KD050FWFLD099	REV	V1.0	Page 12 of 26
----------	---------------	-----	------	---------------

常备库存  
Stock For Sale

长期供货  
Long Time supply

支持小量  
NO MOQ

品种齐全  
In Full Range

### 5.3 LED Backlight Characteristics

The back-light system is edge-lighting type with 12 chips LED

Item	Symbol	Min.	Typ.	Max.	Unit	Note
Forward Current	$I_F$	--	40	--	mA	
Forward Voltage	$V_F$	17.04	18.24	19.44	V	
LCM Luminance ( $I_F = 40\text{mA}$ )	LV	550	650	--	cd/m <sup>2</sup>	Note3
LED life time	Hr	--	50000	--	Hour	Note1,2
Uniformity	Avg	80	--	--	%	Note3

Note1: LED life time (Hr) can be defined as the time in which it continues to operate under the condition:

$T_a = 25 \pm 3 \text{ } ^\circ\text{C}$ , typical IL value indicated in the above table until the brightness becomes less than 50%.

Note 2: The "LED life time" is defined as the module brightness decrease to 50% original brightness at

$T_a = 25 \text{ } ^\circ\text{C}$  and  $I_L = 40\text{mA}$ . The LED lifetime could be decreased if operating  $I_L$  is larger than 40mA. The constant current driving method is suggested.

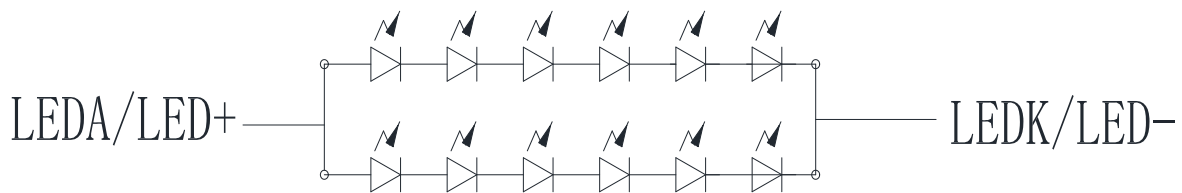

CIRCUIT DIAGRAM

Part. No	KD050FWFLD099	REV	V1.0	Page 13 of 26
----------	---------------	-----	------	---------------

常备库存  
Stock For Sale

长期供货  
Long Time supply

支持小量  
NO MOQ

品种齐全  
In Full Range

Note (3) Luminance Uniformity of these 9 points is defined as below:

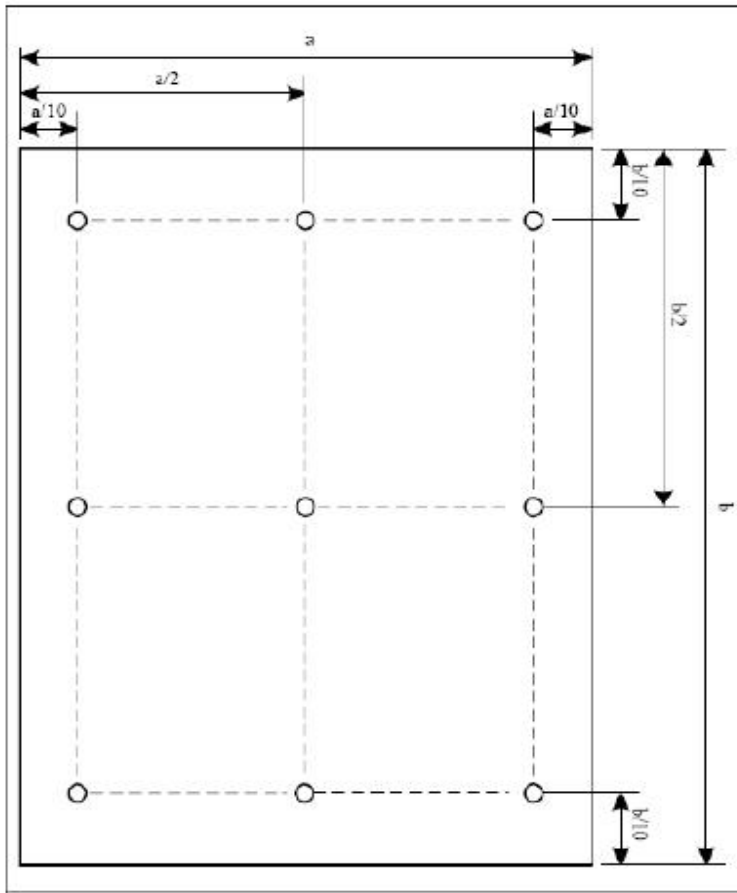

$$\text{Uniformity} = \frac{\text{minimum luminance in 9 points (1-9)}}{\text{maximum luminance in 9 points (1-9)}}$$

$$\text{Luminance} = \frac{\text{Total Luminance of 9 points}}{9}$$

Part. No	KD050FWFLD099	REV	V1.0	Page 14 of 26
常备库存 Stock For Sale	长期供货 Long Time supply	支持小量 NO MOQ	品种齐全 In Full Range	

## 6. LVDS Signal Timing Characteristics

### 6.1 AC Electrical Characteristics

Item	Symbol	Min.	Typ.	Max.	Unit	Note
LVDS Differential input high Threshold voltage	RxVTH	--	--	+100	mV	RXVCM=1.2V
LVDS Differential input low Threshold voltage	RxVTL	-100	--	--	mV	
LVDS Differential input common mode voltage	RxVCM	0.7	--	1.6	V	
LVDS Differential voltage	VID	200	--	600	mV	

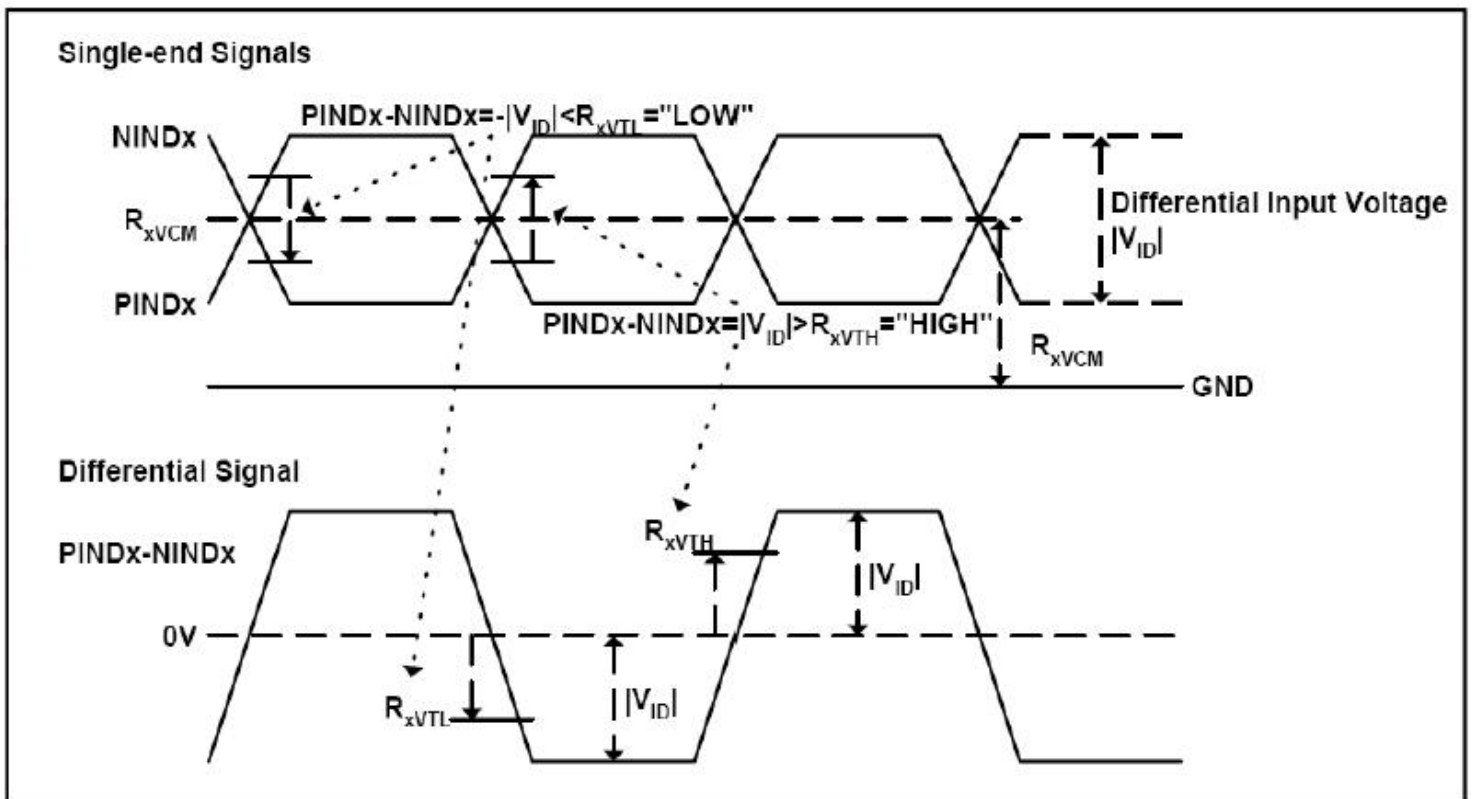

Part. No	KD050FWFLD099	REV	V1.0	Page 15 of 26
----------	---------------	-----	------	---------------

常备库存  
Stock For Sale

长期供货  
Long Time supply

支持小量  
NO MOQ

品种齐全  
In Full Range

## 6.2 Timing Table

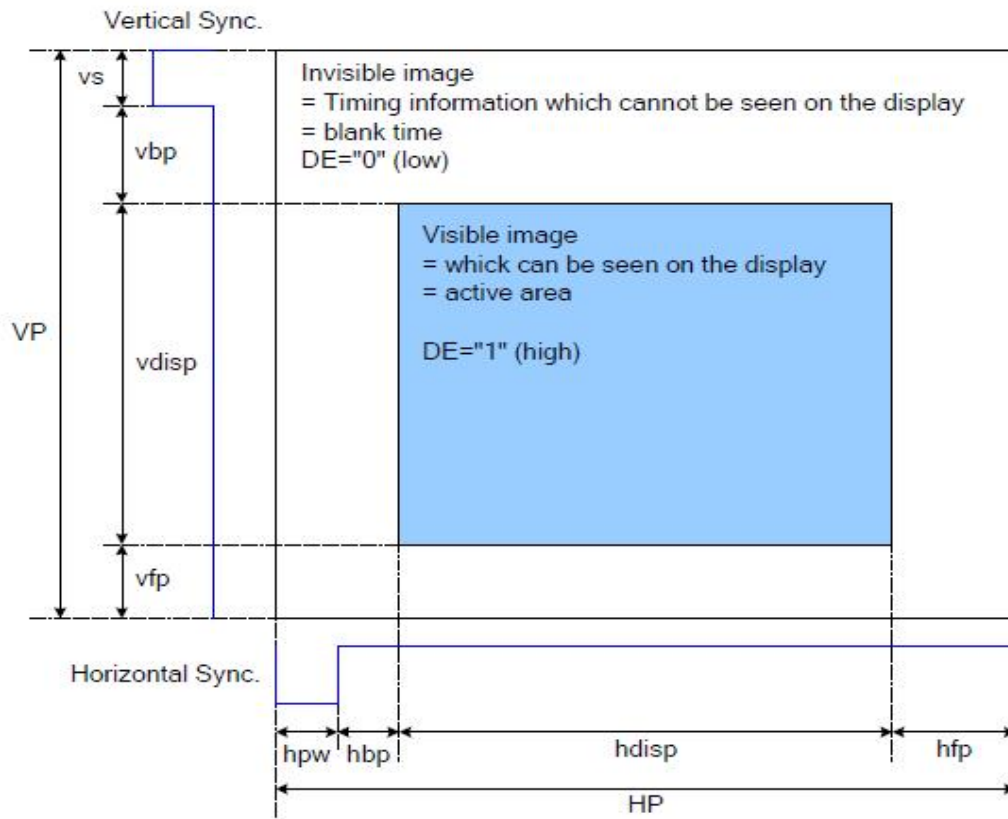

Parameter	Symbol	Min.	Typ.	Max.	Unit
DCLK frequency	FCLK	--	(29)	--	MHz
Horizontal display area	HDISP	--	480	--	Clock
Horizontal Sync. Width	hpw	1	4	--	Clock
Horizontal Sync. Back Porch	hbp	1	30	-	Clock
Horizontal Sync. Front Porch	hfp	1	18	--	Clock
Vertical display area	VDISP	--	854	--	Line
Vertical Sync. Width	vs	1	4	--	Line
Vertical Sync. Back Porch	vbp	1	30	--	Line
Vertical Sync. Front Porch	vfp	1	20	--	Line
Frame-Rate		--	60	--	Hz

Note: 1. Typical value are related to the setting frame rate is 60Hz.

Part. No	KD050FWFLD099	REV	V1.0	Page 16 of 26
----------	---------------	-----	------	---------------

常备库存  
Stock For Sale

长期供货  
Long Time supply

支持小量  
NO MOQ

品种齐全  
In Full Range

### 6.3 LVDS Data Input Format

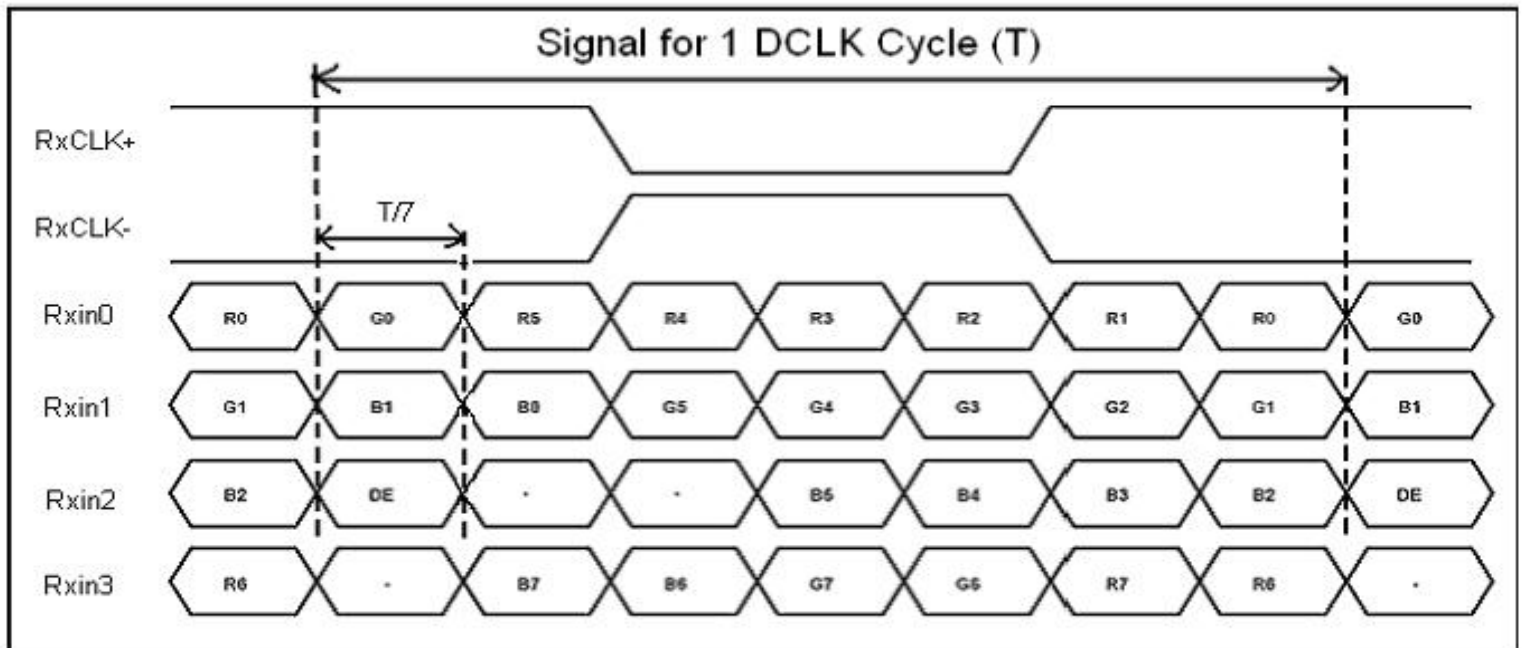

Part. No	KD050FWFLD099	REV	V1.0	Page 17 of 26
----------	---------------	-----	------	---------------

常备库存  
Stock For Sale

长期供货  
Long Time supply

支持小量  
NO MOQ

品种齐全  
In Full Range

## 7. LCD Module Out-Going Quality Level

### 7.1 VISUAL & FUNCTION INSPECTION STANDARD

#### 7.1.1 Inspection conditions

Inspection performed under the following conditions is recommended.

Temperature :  $25\pm 5^{\circ}\text{C}$

Humidity :  $65\%\pm 10\%\text{RH}$

Viewing Angle : Normal viewing Angle.

Illumination: Single fluorescent lamp (300 to 700Lux)

Viewing distance:30-50cm

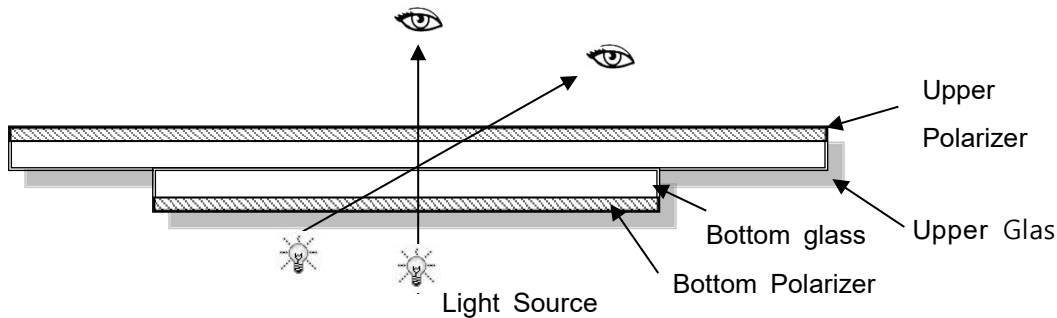

#### 7.1.2 Definition

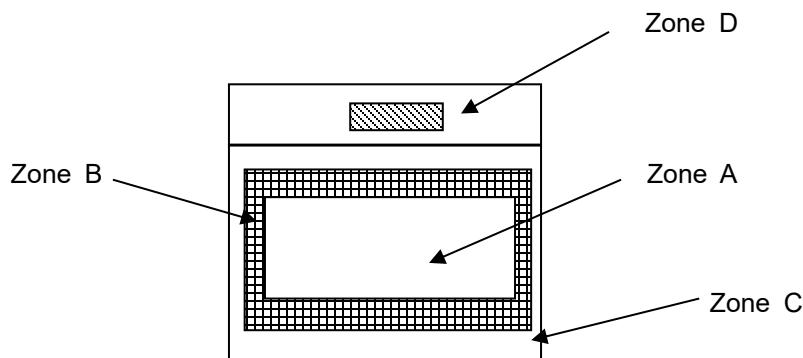

Zone A : Effective Viewing Area(Character or Digit can be seen)

Zone B : Viewing Area except Zone A

Zone C : Outside (Zone A+Zone B) which can not be seen after assembly by customer

Zone D : IC Bonding Area

Part. No	KD050FWFLD099	REV	V1.0	Page 18 of 26
----------	---------------	-----	------	---------------

常备库存  
Stock For Sale

长期供货  
Long Time supply

支持小量  
NO MOQ

品种齐全  
In Full Range

Note:As a general rule ,visual defects in Zone C can be ignored when it doesn't effect product function or appearance after assembly by customer

### 7.1.3 Sampling Plan

According to GB/T 2828-2003 ; , normal inspection, Class II

AQL:

Major defect	Minor defect
0.65	1.5

LCD: Liquid Crystal Display , LCM: Liquid Crystal Module,

No	Items to be inspected	Criteria	Classification of defects
1	Functional defects	1) No display, Open or miss line 2) Display abnormally, Short 3) Backlight no lighting, abnormal lighting. etc...	Major
2	Missing	Missing components and etc...	
3	Outline dimension	Overall outline dimension beyond the drawing is not allowed,deformation and etc...	
4	Color tone	Color unevenness, refer to limited sample	Minor
5	Spot/Line defect	Light dot,Dim spot,(Note1) Polarizer Air Bubble, Polarizer accidented spot and etc.	
6	Soldering appearance	Good soldering , Peeling off is not allowed and etc.	
7	LCD/Polarizer	Black/White spot/line, scratch, crack, etc.	

**Note1:** a) Light dot: Dots appear bright and unchanged in size in which LCD panel is displaying under black pattern.

b) Dim dot: Dots appear dark and unchanged in size in which LCD panel is displaying under pure red, green, blue picture.

Part. No	KD050FWFLD099	REV	V1.0	Page 19 of 26
	常备库存 Stock For Sale	长期供货 Long Time supply	支持少量 NO MOQ	品种齐全 In Full Range

### 7.1.4 Criteria (Visual)

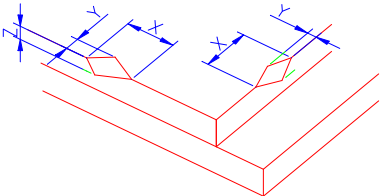
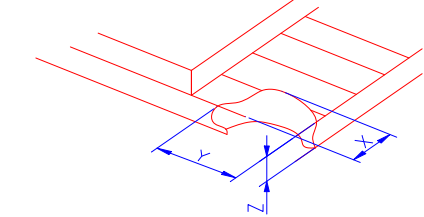
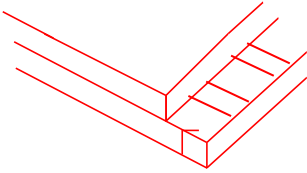
Number	Items	Criteria(mm)						
1.0 LCD Crack/Broken NOTE: X: Length Y: Width Z: Height L: Length of IT O, T: Height of LCD	(1) The edge of LCD broken	 <table border="1" data-bbox="756 846 1453 992"> <thead> <tr> <th>X</th> <th>Y</th> <th>Z</th> </tr> </thead> <tbody> <tr> <td>≤3.0mm</td> <td>&lt;Inner border line of the seal</td> <td>≤T</td> </tr> </tbody> </table>	X	Y	Z	≤3.0mm	<Inner border line of the seal	≤T
X	Y	Z						
≤3.0mm	<Inner border line of the seal	≤T						
	(2) LCD corner broken	 <table border="1" data-bbox="834 1301 1374 1400"> <thead> <tr> <th>X</th> <th>Y</th> <th>Z</th> </tr> </thead> <tbody> <tr> <td>≤3.0mm</td> <td>≤L</td> <td>≤T</td> </tr> </tbody> </table>	X	Y	Z	≤3.0mm	≤L	≤T
X	Y	Z						
≤3.0mm	≤L	≤T						
	(3) LCD crack	 <p style="text-align: center;">Crack Not allowed</p>						

2.0

Spot defect

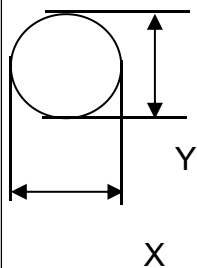

$$\Phi = (X + Y) / 2$$

① light dot ( black/white spot , pinhole, stain, etc. )

Zone Size (mm)	Acceptable Qty		
	A	B	C
$\Phi \leq 0.10$	Ignore		
$0.10 < \Phi \leq 0.25$	3( distance $\geq 10\text{mm}$ )		
$0.25 < \Phi \leq 0.3$	2		
$\Phi > 0.35$	0		

② Dim spot ( light leakage, dent, dark spot, etc )



Zone Size (mm)	Acceptable Qty		
	A	B	C
$\Phi \leq 0.1$	Ignore		
$0.10 < \Phi \leq 0.25$	3( distance $\geq 10\text{mm}$ )		
$0.25 < \Phi \leq 0.3$	2		
$\Phi > 0.35$	0		

③ Polarizer accidented spot

Zone Size (mm)	Acceptable Qty		
	A	B	C
$\Phi \leq 0.2$	Ignore		
$0.3 < \Phi \leq 0.5$	2( distance $\geq 10\text{mm}$ )		
$\Phi > 0.5$	0		

④ Polarizer Bubble

Zone Size (mm)	Acceptable Qty		
	A	B	C
$\Phi \leq 0.2$	Ignore		
$0.3 < \Phi \leq 0.4$	3(distance $\geq 10\text{mm}$ )		
$0.4 < \Phi \leq 0.5$	2		

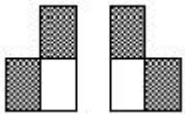
3.0	LCD Pixel defect	<p>Pixel bad points</p> <table border="1"> <thead> <tr> <th data-bbox="539 309 730 360">Item</th> <th data-bbox="730 309 1246 360">Zone A</th> <th data-bbox="1246 309 1497 360">Acceptable Qt</th> </tr> </thead> <tbody> <tr> <td data-bbox="539 360 730 521" rowspan="3">Bright dot</td> <td data-bbox="730 360 1246 416">Random</td> <td data-bbox="1246 360 1497 416">N≤2</td> </tr> <tr> <td data-bbox="730 416 1246 472">2 dots adjacent</td> <td data-bbox="1246 416 1497 472">N≤0</td> </tr> <tr> <td data-bbox="730 472 1246 521">3 dots adjacent</td> <td data-bbox="1246 472 1497 521">N≤0</td> </tr> <tr> <td data-bbox="539 521 730 689" rowspan="3">Dark dot</td> <td data-bbox="730 521 1246 577">Random</td> <td data-bbox="1246 521 1497 577">N≤2</td> </tr> <tr> <td data-bbox="730 577 1246 633">2 dots adjacent</td> <td data-bbox="1246 577 1497 633">N≤0</td> </tr> <tr> <td data-bbox="730 633 1246 689">3 dots adjacent</td> <td data-bbox="1246 633 1497 689">N≤0</td> </tr> <tr> <td data-bbox="539 689 730 1003">Distance</td> <td data-bbox="730 689 1246 1003">           1. Minimum Distance Between Bright dots.            2. Minimum Distance Between dark dots            3. Minimum Distance Between dark and bright dot.         </td> <td data-bbox="1246 689 1497 1003">5mm</td> </tr> <tr> <td colspan="2" data-bbox="539 1003 1246 1059">Total bright and dark dot</td> <td data-bbox="1246 1003 1497 1059">N≤4</td> </tr> </tbody> </table> <p>Note:</p> <p>A) Bright dot: Dots appear bright and unchanged in size in which LCD panel is displaying under black pattern.</p> <p>B) Dark dot: Dots appear dark and unchanged in size in which LCD panel is displaying under pure red, green, blue picture.</p> <p>C) 2 dot adjacent = 1 pair = 2 dots</p> <p>Picture:</p> <div style="display: flex; justify-content: space-around; align-items: flex-start;"> <div style="text-align: center;">  <p>2 dot adjacent</p> </div> <div style="text-align: center;">  <p>2 dot adjacent</p> </div> </div> <div style="display: flex; justify-content: space-around; align-items: flex-start; margin-top: 20px;"> <div style="text-align: center;">  <p>2 dot adjacent (vertical)</p> </div> <div style="text-align: center;">  <p>2 dot adjacent (slant)</p> </div> </div>	Item	Zone A	Acceptable Qt	Bright dot	Random	N≤2	2 dots adjacent	N≤0	3 dots adjacent	N≤0	Dark dot	Random	N≤2	2 dots adjacent	N≤0	3 dots adjacent	N≤0	Distance	1. Minimum Distance Between Bright dots. 2. Minimum Distance Between dark dots 3. Minimum Distance Between dark and bright dot.	5mm	Total bright and dark dot		N≤4
Item	Zone A	Acceptable Qt																							
Bright dot	Random	N≤2																							
	2 dots adjacent	N≤0																							
	3 dots adjacent	N≤0																							
Dark dot	Random	N≤2																							
	2 dots adjacent	N≤0																							
	3 dots adjacent	N≤0																							
Distance	1. Minimum Distance Between Bright dots. 2. Minimum Distance Between dark dots 3. Minimum Distance Between dark and bright dot.	5mm																							
Total bright and dark dot		N≤4																							

4.0	Line defect (LCD /Polarizer backlight black/white line, scratch, stain)  W: width, L : length  N : Count	<table border="1"> <thead> <tr> <th rowspan="2">Width(mm)</th> <th rowspan="2">Length(m)</th> <th colspan="3">Acceptable Qty</th> </tr> <tr> <th>A</th> <th>B</th> <th>C</th> </tr> </thead> <tbody> <tr> <td><math>\Phi \leq 0.05</math></td> <td>Ignore</td> <td colspan="2">Ignore</td> <td rowspan="3">Ignore</td> </tr> <tr> <td><math>0.05 &lt; W \leq 0.06</math></td> <td><math>L \leq 3.0</math></td> <td colspan="2"><math>N \leq 2</math></td> </tr> <tr> <td><math>0.07 &lt; W \leq 0.08</math></td> <td><math>L \leq 2.0</math></td> <td colspan="2"><math>N \leq 1</math></td> </tr> <tr> <td><math>0.08 &lt; W</math></td> <td colspan="4">Define as spot defect</td> </tr> </tbody> </table>	Width(mm)	Length(m)	Acceptable Qty			A	B	C	$\Phi \leq 0.05$	Ignore	Ignore		Ignore	$0.05 < W \leq 0.06$	$L \leq 3.0$	$N \leq 2$		$0.07 < W \leq 0.08$	$L \leq 2.0$	$N \leq 1$		$0.08 < W$	Define as spot defect			
		Width(mm)			Length(m)	Acceptable Qty																						
			A	B		C																						
		$\Phi \leq 0.05$	Ignore	Ignore		Ignore																						
		$0.05 < W \leq 0.06$	$L \leq 3.0$	$N \leq 2$																								
$0.07 < W \leq 0.08$	$L \leq 2.0$	$N \leq 1$																										
$0.08 < W$	Define as spot defect																											
5.0	Electronic Components SMT.	Not allow missing parts, solderless connection, cold solder joint, mismatch, The positive and negative polarity opposite																										
6.0	Display color & Brightness.	1. Color: Measuring the color coordinates, The measurement standard according to the datasheet or samples. 2. Brightness: Measuring the brightness of White screen, The measurement standard according to the datasheet or Samples.																										
7.0	LCD Mura/Waving/ Hot spot	Not visible through 5% ND filter in 50% gray or judge by limit sample if necessary.																										

Criteria ( functional items)

Number	Items	Criteria (mm)
1	No display	Not allowed
2	Missing segment	Not allowed
3	Short	Not allowed
4	Backlight no lighting	Not allowed

## 8. Reliability Test Result

Item	Condition	Inspection after test
High Temperature Operating	70°C,96H	Inspection after 2~4hours storage at room temperature, the sample shall be free from defects: 1.Air bubble in the LCD; 2.Non-display; 3.Missing segments/line; 4.Glass crack; 5.Current IDD is twice higher than initial value.
Low Temperature Operating	-20°C, 96HR	
High Temperature Storage	80°C, 96HR	
Low Temperature Storage	-30°C, 96HR	
High Temperature & High Humidity Operating	+60°C, 90% RH ,96 hours.	
Thermal Shock (Non-operation)	-30°C,30 min ↔ +60°C,30 min, Change time:5min 20CYC.	
ESD test	C=150pF, R=330,5points/panel Air:±8KV, 5times; Contact:±6KV, 5 times; (Environment: 15°C~35°C, 30%~60%).	
Vibration (Non-operation)	Frequency range:10~55Hz, Stroke:1.5mm Sweep:10Hz~55Hz~10Hz 2 hours for each direction of X.Y.Z. (6 hours for total) (Package condition).	
Box Drop Test	1 Corner 3 Edges 6 faces,80cm(MEDIUM BOX)	

Remark:

- 1.The test samples should be applied to only one test item.
- 2.Sample size for each test item is 5~10pcs.
- 3.For Damp Proof Test, Pure water(Resistance > 10MΩ) should be used.
- 4.In case of malfunction defect caused by ESD damage, if it would be recovered to normal state after resetting, it would be judged as a good part.
- 5.Failure Judgment Criterion: Basic Specification, Electrical Characteristic, Mechanical Characteristic, Optical Characteristic.
6. The color fading mura of polarizing filter should not care.

Part. No	KD050FWFLD099	REV	V1.0	Page 24 of 26
----------	---------------	-----	------	---------------

常备库存  
Stock For Sale

长期供货  
Long Time supply

支持小量  
NO MOQ

品种齐全  
In Full Range

## 9. Cautions and Handling Precautions

### 9.1 Handling and Operating the Module

- (1) When the module is assembled, it should be attached to the system firmly.  
Do not warp or twist the module during assembly work.
- (2) Protect the module from physical shock or any force. In addition to damage, this may cause improper operation or damage to the module and back-light unit.
- (3) Note that polarizer is very fragile and could be easily damaged. Do not press or scratch the surface.
- (4) Do not allow drops of water or chemicals to remain on the display surface.  
If you have the droplets for a long time, staining and discoloration may occur.
- (5) If the surface of the polarizer is dirty, clean it using some absorbent cotton or soft cloth.
- (6) The desirable cleaners are water, IPA (Isopropyl Alcohol) or Hexane.  
Do not use ketene type materials (ex. Acetone), Ethyl alcohol, Toluene, Ethyl acid or Methyl chloride. It might permanent damage to the polarizer due to chemical reaction.
- (7) If the liquid crystal material leaks from the panel, it should be kept away from the eyes or mouth. In case of contact with hands, legs, or clothes, it must be washed away thoroughly with soap.
- (8) Protect the module from static; it may cause damage to the CMOS ICs.
- (9) Use finger-stalls with soft gloves in order to keep display clean during the incoming inspection and assembly process.
- (10) Do not disassemble the module.
- (11) Protection film for polarizer on the module shall be slowly peeled off just before use so that the electrostatic charge can be minimized.
- (12) Pins of I/F connector shall not be touched directly with bare hands.
- (13) Do not connect, disconnect the module in the "Power ON" condition.
- (14) Power supply should always be turned on/off by the item 6.1 Power On Sequence & 6.2 Power Off Sequence

### 9.2 Storage and Transportation.

- (1) Do not leave the panel in high temperature, and high humidity for a long time.  
It is highly recommended to store the module with temperature from 0 to 35 °C and relative humidity of less than 70%
- (2) Do not store the TFT-LCD module in direct sunlight.
- (3) The module shall be stored in a dark place. When storing the modules for a long time, be sure to adopt effective measures for protecting the modules from strong ultraviolet radiation, sunlight, or fluorescent light.
- (4) It is recommended that the modules should be stored under a condition where no condensation is allowed. Formation of dewdrops may cause an abnormal operation or a failure of the module.  
In particular, the greatest possible care should be taken to prevent any module from being operated where condensation has occurred inside.
- (5) This panel has its circuitry FPC on the bottom side and should be handled carefully in order not to be stressed.

Part. No	<b>KD050FWFLD099</b>	REV	V1.0	Page 25 of 26
	常备库存 Stock For Sale	长期供货 Long Time supply	支持小量 NO MOQ	品种齐全 In Full Range

## 10. Packing

---TBD-----

Part. No	KD050FWFLD099	REV	V1.0	Page 26 of 26
	常备库存 Stock For Sale	长期供货 Long Time supply	支持少量 NO MOQ	品种齐全 In Full Range