

TITLE:**DV550FHM-NV8****Preliminary Product Specification****Rev. P2****BEIJING BOE DISPLAY TECHNOLOGY**

Contents

No	ITEM	Page
	REVISIONS HISTORY	2
	CONTENTS	3
1	GENERAL DESCRIPTION	4
	1.1 Introduction	
	1.2 Features	
	1.3 Applications	
	1.4 General Specification	
2	ABSOLUTE MAXIMUM RATINGS	6
3	ELECTRICAL SPECIFICATIONS	7
	3.1 Open Cell Electrical Specifications	
	3.2 Converter Electrical Specifications	
4	INTERFACE CONNECTION	9
	4.1 Open Cell Input Signal & Power	
	4.2 BLU Input Signal & Power	
	4.3 LVDS Receiver Type	
5	SIGNAL TIMING SPECIFICATIONS	14
	5.1 Timing Parameters	
	5.2 Signal Timing Waveform	
	5.3 Input Signals, Basic Display Colors & Gray Scale Of Colors	
	5.4 Power Sequence	
6	OPTICAL SPECIFICATIONS	20
7	MECHANICAL CHARACTERISTICS	22
8	RELIABILITY	23
9	PRODUCT SERIAL NUMBER	24
10	PACKING INFORMATION	25
11	HANDING & CAUTIONS	27
12	APPENDIX	28

1.0 GENERAL DESCRIPTION

1.1 Introduction

DV550FHM-NV8 is a color active matrix TFT LCD Module using amorphous silicon TFT's (Thin Film Transistors) as an active switching devices. This module has a 55inch diagonally measured active area with FHD resolutions (1920 horizontal by 1080 vertical pixel array). Each pixel is divided into RED, GREEN, BLUE dots which are arranged in vertical stripe and this module can display 16.7M colors. The TFT-LCD panel used for this module is adapted for a low reflection and higher color type.

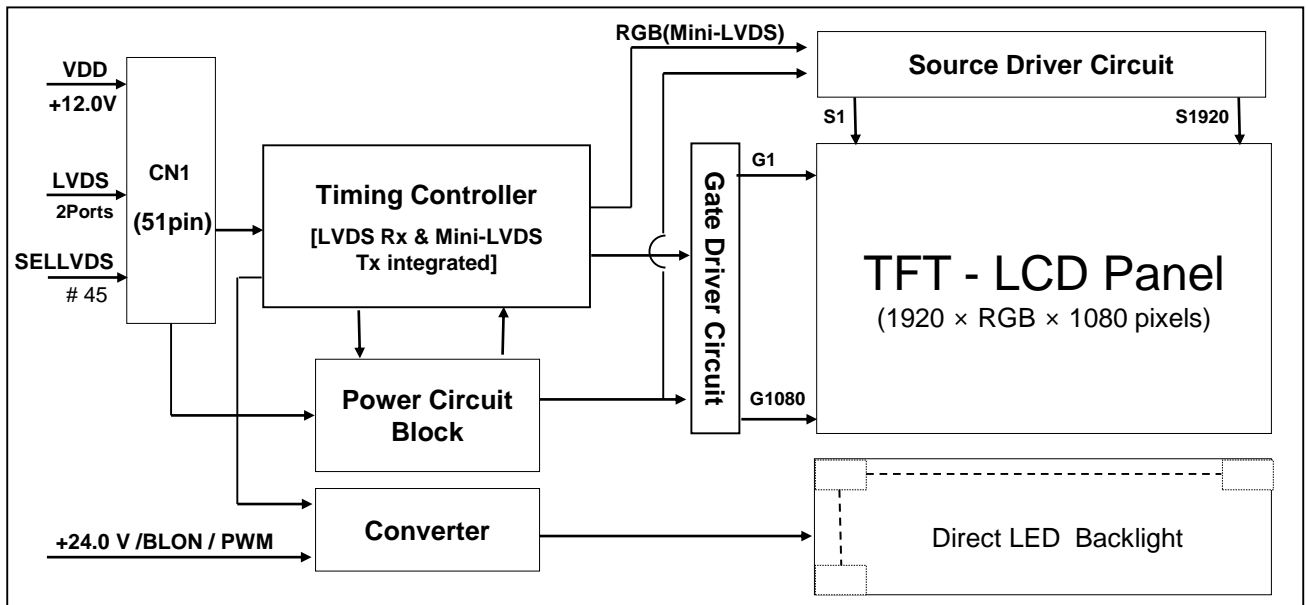

1.2 Features

- LVDS interface with 2 pixel / clock
- High-speed response
- 8-bit color depth, display 16.7M colors
- Direct LED Backlight
- DE (Data Enable) only mode
- ADS technology is applied for high display quality
- RoHS compliant

1.3 Application

- Home Alone Multimedia TFT-LCD TV
- Display Terminals for Control System
- Full High Definition TV(FHD TV)
- SLFD application Products

1.4 General Specification

< Table 1. General Specifications >

Parameter	Specification	Unit	Remark
MDL Outline	1213.5 (H) ×684.3(V)	mm	
Active area	1209.6 (H) ×680.4(V)	mm	
Number of pixels	1920(H) ×1080(V)	pixels	
Pixel pitch	210(H) ×RGB×630(V)	μm	
Pixel arrangement	Pixels RGB Vertical stripe		
Display colors	16.7M(8bits-true)	colors	
Display mode	Transmission mode, Normally Black		
Brightness	500(Typ.)	nit	Center point
MDL Thickness	40.9	mm	Body
Weight	15,800(Typ.)	gram	
Power Consumption	175(Typ.)	Watt	
Surface Treatment	Haze25%,3H,(Front Polarizer) Clear (Bottom Polarizer)		
Life time	30,000	Hrs	Note 1

Note 1:The life time is determined as the time which luminance of LED is 50% compare to the initial value at the typical LED current on condition of continuous operating in LCM state at 25±2 °C

2.0 ABSOLUTE MAXIMUM RATINGS

The followings are maximum values which, if exceed, may cause faulty operation or damage to the unit. The operational and non-operational maximum voltage and current values are listed in Table 2.

< Table 2. **Open Cell Electrical Specifications** >

[VSS=GND=0V]

Parameter		Symbol	Min.	Max.	Unit	Remark
Power Supply Voltage	LCD Module	V_{DD}	$V_{SS}-0.3$	13.2	V	Ta = 25 °C
	Converter	VBL	$V_{SS}-0.3$	26.4	V	
Operating Temperature		T_{OP}	0	+50	°C	Note 1
		T_{SUR}	0	+60	°C	
Storage Temperature		T_{ST}	-20	+60	°C	
Operating Ambient Humidity		Hop	10	80	%RH	
Storage Humidity		Hst	10	80	%RH	

Note 1 : Temperature and relative humidity range are shown in the figure below.
Wet bulb temperature should be 39 °C max. and no condensation of water.

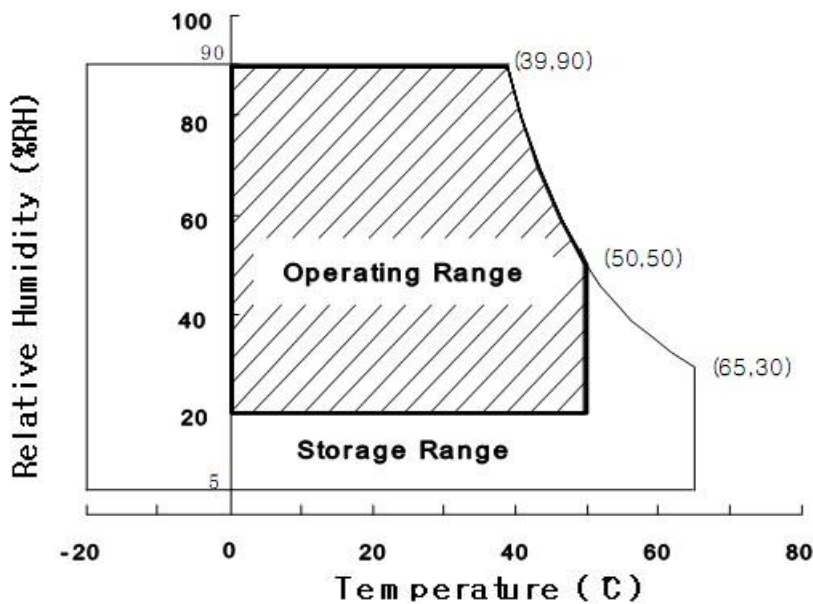

3.0 ELECTRICAL SPECIFICATIONS

3.1 Open Cell Electrical Specifications

< Table 3. Open Cell Electrical Specifications >

[Ta =25±2 °C]

Parameter		Symbol	Values			Unit	Remark
			Min	Typ	Max		
Power Supply Input Voltage		VDD	10.8	12	13.2	Vdc	
Power Supply Ripple Voltage		VRP	-	-	300	mV	
Power Supply Current		IDD	-	560	950	mA	Note 1
Power Consumption		PDD	-	6.8	11.4	Watt	
Rush current		IRUSH	-	-	3	A	Note 2
LVDS Interface	Differential Input High Threshold Voltage	VLVTH	+100		+600	mV	
	Differential Input Low Threshold Voltage	VLVTL	-600		-100	mV	
	Common Input Voltage	VLVC	1.0	1.2	1.4	V	
TCON Option Selection Voltage	Input High Threshold Voltage	VIH	2.7	-	3.3	V	
	Input Low Threshold Voltage	VIL	0	-	0.6	V	

Note 1 : The supply voltage is measured and specified at the interface connector of LCM.

The current draw and power consumption specified is for VDD=12.0V,

Frame rate $f_v=60\text{Hz}$ and Clock frequency = 75.4MHz.

Test Pattern of power supply current

a) Typ : Color Test (L0/L255)

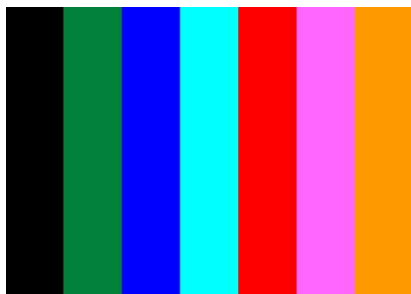

b) Max : Horizontal 1 Line (L0/L255)

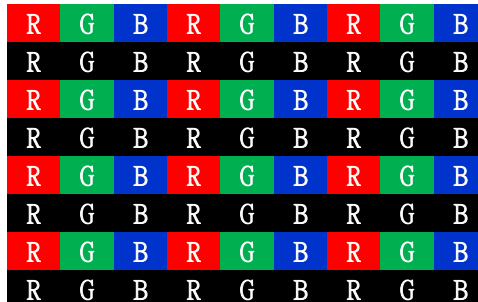

Note 2 : The duration of rush current is about 2ms and rising time of Power Input is 1ms(min)

3.2 Converter Electrical Specifications

< Table 4. Converter Electrical Specifications >

[Ta =25±2 °C]

Parameter	Symbol	Values			Unit	Remark
		Min	Typ	Max		
Power Supply Input Voltage	V_{BL}	21.6	24	26.4	Vdc	
Power Supply Ripple Voltage	V_{RP}	-	-	300	mV	
Power Supply Current	I_{DD}	-	7.0	8	A	
Power Consumption	P_{DD}	-	168	192	Watt	Note 1
Backlight On/Off Control Voltage	$V_{BLON} (off)$	0	-	0.3	V	
	$V_{BLON} (on)$	2.4	3.3	3.6	V	
Backlight PWM	High Level	2.4	3.3	3.6	V	On duty
	Low Level	0	-	0.3	V	Off duty
	Dimming Ratio	1	-	100	%	Note 2
	PWM Frequency	100	-	300	Hz	

Note 1: The specified current and power consumption are under the typical supply input voltage, 24V. It is total power consumption.

Note 2 : High-duty = On/(On+Off) * 100

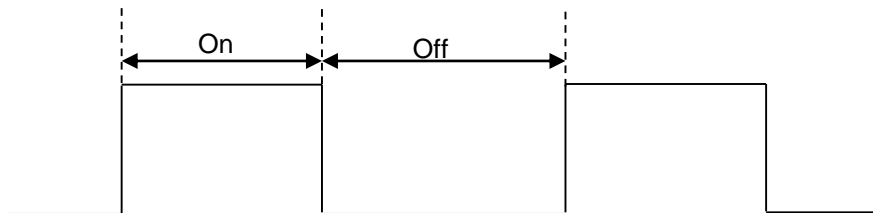

4.0 INTERFACE CONNECTION

4.1 Open Cell Input Signal & Power

- Connector : IS050-C51B-C39-S (UJU) / FI-RE51S-HF-R1500 (JAE) or Equivalent.

< Table 5. Input Connector Pin Configuration >

Pin No	Symbol	Description	Pin No	Symbol	Description
1	VDD	Input Voltage	20	CH1[3]-	First pixel negative LVDS differential data input. Pair3
2	VDD	Input Voltage	21	CH1[3]+	First pixel positive LVDS differential data input. Pair3
3	VDD	Input Voltage	22	NC	Not Connected (1)
4	VDD	Input Voltage	23	NC	Not Connected (1)
5	VDD	Input Voltage	24	GND	Ground
6	NC	Not Connected (1)	25	CH2[0]-	Second pixel negative LVDS differential data input. Pair0
7	GND	Ground	26	CH2[0]+	Second pixel positive LVDS differential data input. Pair0
8	GND	Ground	27	CH2[1]-	Second pixel negative LVDS differential data input. Pair1
9	GND	Ground	28	CH2[1]+	Second pixel positive LVDS differential data input. Pair1
10	CH1[0]-	First pixel negative LVDS differential data input. Pair0	29	CH2[2]-	Second pixel negative LVDS differential data input. Pair2
11	CH1[0]+	First pixel positive LVDS differential data input. Pair0	30	CH2[2]+	Second pixel positive LVDS differential data input. Pair2
12	CH1[1]-	First pixel negative LVDS differential data input. Pair1	31	GND	Ground
13	CH1[1]+	First pixel positive LVDS differential data input. Pair1	32	CH2CLK-	First pixel negative LVDS clock
14	CH1[2]-	First pixel negative LVDS differential data input. Pair2	33	CH2CLK+	First pixel positive LVDS clock
15	CH1[2]+	First pixel positive LVDS differential data input. Pair2	34	GND	Ground
16	GND	Ground	35	CH2[3]-	Second pixel negative LVDS differential data input. Pair3
17	CH1CLK-	First pixel negative LVDS clock	36	CH2[3]+	Second pixel positive LVDS differential data input. Pair3
18	CH1CLK+	First pixel positive LVDS clock	37	NC	Not Connected (1)
19	GND	Ground	38	NC	Not Connected (1)

Pin No	Symbol	Description	Pin No	Symbol	Description
39	GND	Ground	46	NC	Not Connected (1)
40	NC	Not Connected (1)	47	NC	Not Connected (1)
41	Local_ON	High or Open : Local dimming Enable (Only)	48	NC	Not Connected (1)
42	NC	Not Connected (1)	49	NC	Not Connected (1)
43	NC	Not Connected (1)	50	NC	Not Connected (1)
44	NC	Not Connected (1)	51	NC	Not Connected (1)
45	SELLVDS	High: VESA Low or Open: JEIDA			

Notes : 1. NC(Not Connected) : This pins are only used for BOE internal operations.

2. Input Level of LVDS signal is based on the IEA 664 Standard.

3. Pin 41 Local_ON: This pin is used for selecting local dimming ON/OFF

4. Pin 45 SELLVDS : This pin is used for selecting LVDS signal data format.

If this Pin : High (3.3V) → VESA LVDS format

Otherwise : Low (GND) or Open(NC) → JEIDA LVDS format

Rear view of LCM

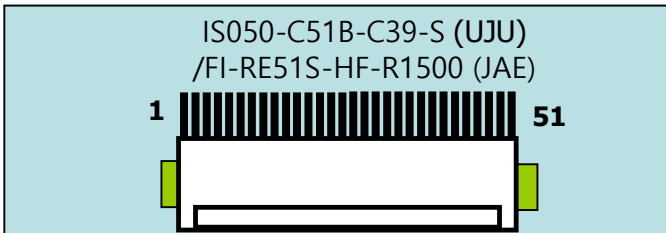

4.2 BLU Input Signal & Power

- BLU Connector(CN1 & CN2) : CI0114M1HR0-NH (Cvilux)or Equivalent.

< Table 6. Input Connector Pin Configuration CN1 >

Pin No	Symbol	Description	Pin No	Symbol	Description
1	VIN	Operating Voltage Supply, +24V DC regulated	8	GND	Ground and Current Return
2	VIN	Operating Voltage Supply, +24V DC regulated	9	GND	Ground and Current Return
3	VIN	Operating Voltage Supply, +24V DC regulated	10	GND	Ground and Current Return
4	VIN	Operating Voltage Supply, +24V DC regulated	11	NC	No Connection
5	VIN	Operating Voltage Supply, +24V DC regulated	12	BLON	BLU On-Off control: DC 0 to 0.3V off , DC 2.4 to 3.6V On
6	GND	Ground and Current Return	13	PWM	1%≤Duty≤100%
7	GND	Ground and Current Return	14	NC	No Connection

< Table 7. Input Connector Pin Configuration CN2 >

Pin No	Symbol	Description	Pin No	Symbol	Description
1	VIN	Operating Voltage Supply, +24V DC regulated	8	GND	Ground and Current Return
2	VIN	Operating Voltage Supply, +24V DC regulated	9	GND	Ground and Current Return
3	VIN	Operating Voltage Supply, +24V DC regulated	10	GND	Ground and Current Return
4	VIN	Operating Voltage Supply, +24V DC regulated	11	NC	No Connection
5	VIN	Operating Voltage Supply, +24V DC regulated	12	NC	No Connection
6	GND	Ground and Current Return	13	NC	No Connection
7	GND	Ground and Current Return	14	NC	No Connection

4.3 LVDS Receiver Type

- LVDS Receiver : Timing Controller (LVDS Rx merged) / LVDS Data : Pixel Data

< Table 8. 8-bit LVDS Type >

Channel No.	Data No.	8-bit LVDS Type	
		VESA	JEIDA
0	Bit-0	R0	R2
	Bit-1	R1	R3
	Bit-2	R2	R4
	Bit-3	R3	R5
	Bit-4	R4	R6
	Bit-5	R5	R7
	Bit-6	G0	G2
1	Bit-0	G1	G3
	Bit-1	G2	G4
	Bit-2	G3	G5
	Bit-3	G4	G6
	Bit-4	G5	G7
	Bit-5	B0	B2
	Bit-6	B1	B3
2	Bit-0	B2	B4
	Bit-1	B3	B5
	Bit-2	B4	B6
	Bit-3	B5	B7
	Bit-4	HS	HS
	Bit-5	VS	VS
	Bit-6	DE	DE
3	Bit-0	R6	R0
	Bit-1	R7	R1
	Bit-2	G6	G0
	Bit-3	G7	G1
	Bit-4	B6	B0
	Bit-5	B7	B1
	Bit-6	-	

5.0 SIGNAL TIMING SPECIFICATION

5.1 Timing Parameters (DE only mode)

< Table 9. Timing Table >

Item		Symbols	Min	Typ	Max	Unit	Notes
Horizontal	Display Period	t _{HV}	960	960	960	t _{CLK}	2 ports
	Blank	t _{HB}	90	140	190	t _{CLK}	1
	Total	t _{HP}	1050	1100	1150	t _{CLK}	
Vertical	Display Period	t _{VV}	-	1080	-	Lines	1
	Blank	t _{VB}	20	45	69	Lines	
	Total	t _{VP}	1100	1125	1149	Lines	

Item		Symbols	Min	Typ	Max	Unit	Notes
Frequency	DCLK	f _{CLK}	66.00	74.25	82	MHz	2 ports
	Horizontal	f _H	62.7	67.5	72.3	KHz	2
	Total	f _V	57	60	63	Hz	2

Notes:

1. The input of HSYNC & VSYNC signal does not have an effect on normal operation (DE Only Mode). If you use spread spectrum of EMI, add some additional clock to minimum value for clock margin.
2. The performance of the electro-optical characteristics may be influenced by variance of the vertical refresh rate and the horizontal frequency.
3. LVDS Receiver Spread spectrum Clock is defined as below figure.

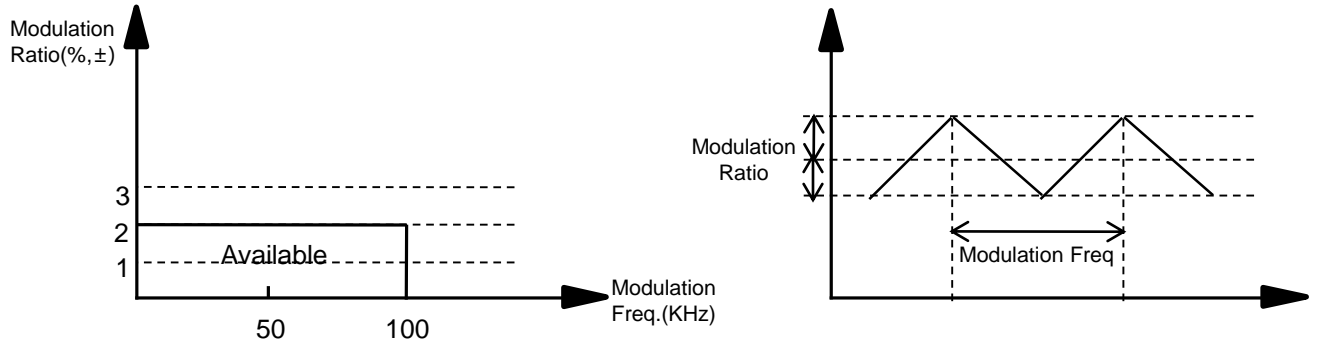

Please pay attention to the followings when you set Spread Spectrum Rate(SSR) and Modulation Frequency(FMOD)

1. Please set proper Spread Spectrum Rate(SSR) and Modulation Frequency (FMOD) of TV system LVDS output.
2. Please check FOS after you set Spread Spectrum Rate(SSR) and Modulation Frequency(FMOD) to avoid abnormal display. Especially, harmonic noise can appear when you use Spread Spectrum under FMOD 30 KHz.

5.2 Signal Timing Waveform

5.2.1 LVDS Input Signal Timing Diagram

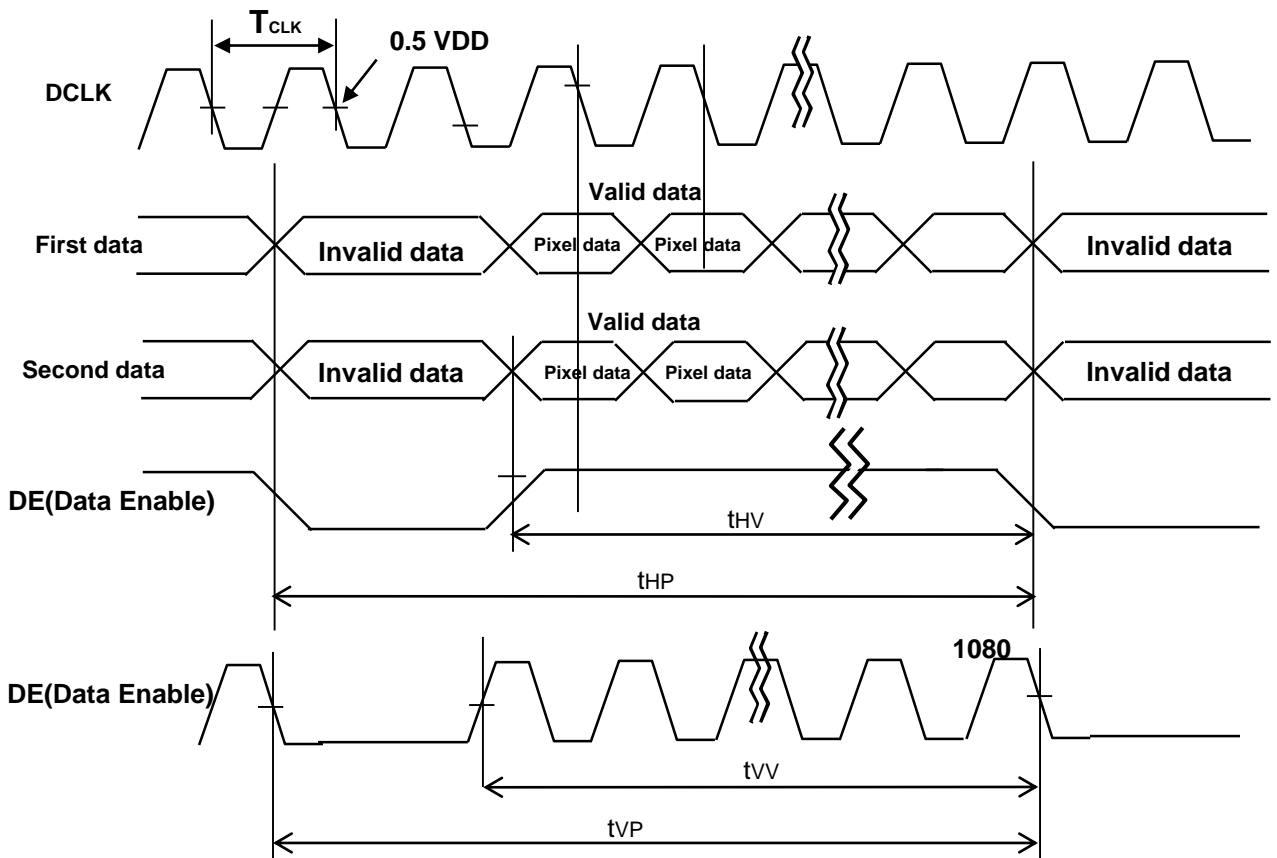

5.2.2 LVDS Input Signal Characteristics

1) DC Specification

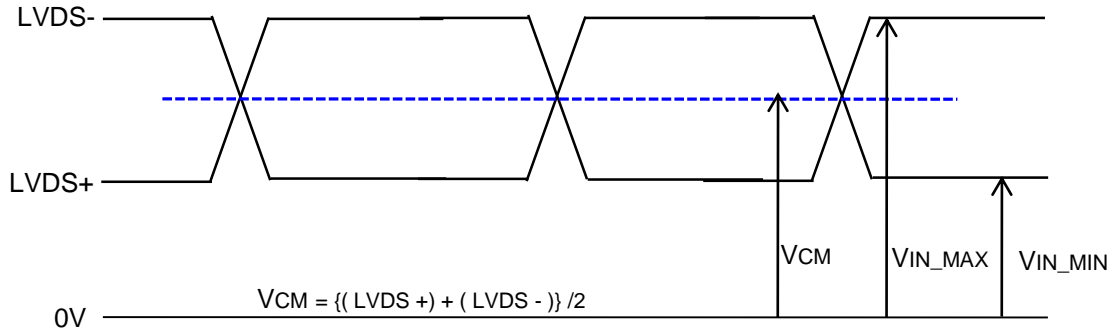

Description	Symbols	Min	Max	Unit
LVDS Common mode Voltage	VCM	1.0	1.4	V
LVDS Input Voltage Range	VIN	0.7	1.7	V
Change in common mode Voltage	ΔV_{CM}	-	200	mV

2) AC Specification

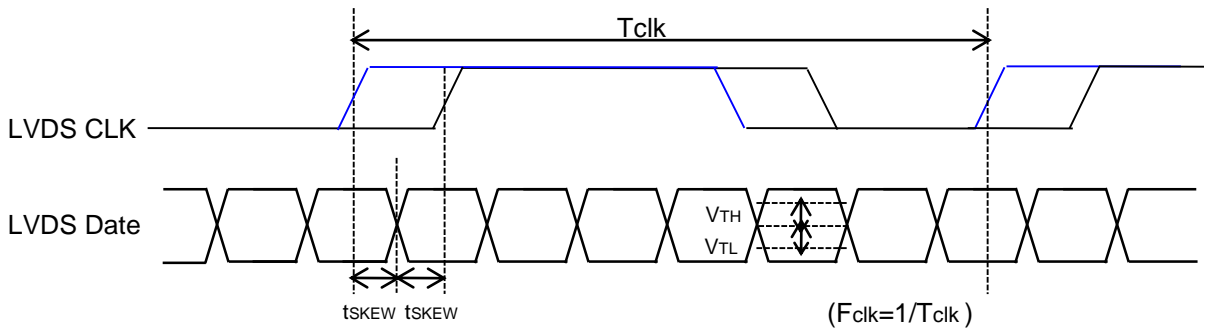

Description	Symbols	Min	Max	Unit	Notes
LVDS Differential Voltage	V_{TH}	100	600	mV	Tested with Differential Probe
	V_{TL}	-600	-100	mV	
LVDS Clock to Data Skew	t_{SKEW}	-	400	ps	
LVDS Clock to Clock Skew (Even to Odd)	t_{SKEW_EO}	-	400	ps	

5.3 Input Signals, Basic Display Colors and Gray Scale of Colors

< Table 10. Input Signal and Display Color Table >

Color & Gray Scale		Input Data Signal																							
		Red Data								Green Data				Blue Data											
		R7	R6	R5	R4	R3	R2	R1	R0	G7	G6	G5	G4	G3	G2	G1	G0	B7	B6	B5	B4	B3	B2	B1	B0
Basic Colors	Black	0	0	0	0	0	0	0	0	0	0	0	0	0	0	0	0	0	0	0	0	0	0	0	
	Blue	0	0	0	0	0	0	0	0	0	0	0	0	0	0	0	0	1	1	1	1	1	1	1	1
	Green	0	0	0	0	0	0	0	0	1	1	1	1	1	1	1	1	0	0	0	0	0	0	0	0
	Cyan	0	0	0	0	0	0	0	0	1	1	1	1	1	1	1	1	1	1	1	1	1	1	1	1
	Red	1	1	1	1	1	1	1	1	0	0	0	0	0	0	0	0	0	0	0	0	0	0	0	0
	Magenta	1	1	1	1	1	1	1	1	0	0	0	0	0	0	0	0	1	1	1	1	1	1	1	1
	Yellow	1	1	1	1	1	1	1	1	1	1	1	1	1	1	1	1	0	0	0	0	0	0	0	0
	White	1	1	1	1	1	1	1	1	1	1	1	1	1	1	1	1	1	1	1	1	1	1	1	1
Gray Scale of Red	Black	0	0	0	0	0	0	0	0	0	0	0	0	0	0	0	0	0	0	0	0	0	0	0	
	△	0	0	0	0	0	0	0	1	0	0	0	0	0	0	0	0	0	0	0	0	0	0	0	
	Darker	0	0	0	0	0	0	1	0	0	0	0	0	0	0	0	0	0	0	0	0	0	0	0	
	△	↑								↑				↑											
	▽	↓								↓				↓											
	Brighter	1	1	1	1	1	1	0	1	0	0	0	0	0	0	0	0	0	0	0	0	0	0	0	0
	▽	1	1	1	1	1	1	1	0	0	0	0	0	0	0	0	0	0	0	0	0	0	0	0	0
	Red	1	1	1	1	1	1	1	1	0	0	0	0	0	0	0	0	0	0	0	0	0	0	0	0
Gray Scale of Green	Black	0	0	0	0	0	0	0	0	0	0	0	0	0	0	0	0	0	0	0	0	0	0	0	
	△	0	0	0	0	0	0	0	0	0	0	0	0	0	0	0	1	0	0	0	0	0	0	0	
	Darker	0	0	0	0	0	0	0	0	0	0	0	0	0	0	1	0	0	0	0	0	0	0	0	
	△	↑								↑				↑											
	▽	↓								↓				↓											
	Brighter	0	0	0	0	0	0	0	0	1	1	1	1	1	1	0	1	0	0	0	0	0	0	0	0
	▽	0	0	0	0	0	0	0	0	1	1	1	1	1	1	1	0	0	0	0	0	0	0	0	0
	Green	0	0	0	0	0	0	0	0	1	1	1	1	1	1	1	1	0	0	0	0	0	0	0	0
Gray Scale of Blue	Black	0	0	0	0	0	0	0	0	0	0	0	0	0	0	0	0	0	0	0	0	0	0	0	
	△	0	0	0	0	0	0	0	0	0	0	0	0	0	0	0	0	0	0	0	0	0	0	1	
	Darker	0	0	0	0	0	0	0	0	0	0	0	0	0	0	0	0	0	0	0	0	0	0	1	
	△	↑								↑				↑											
	▽	↓								↓				↓											
	Brighter	0	0	0	0	0	0	0	0	0	0	0	0	0	0	0	0	1	1	1	1	1	1	0	1
	▽	0	0	0	0	0	0	0	0	0	0	0	0	0	0	0	0	1	1	1	1	1	1	1	0
	Blue	0	0	0	0	0	0	0	0	0	0	0	0	0	0	0	0	1	1	1	1	1	1	1	1
Gray Scale of White	Black	0	0	0	0	0	0	0	0	0	0	0	0	0	0	0	0	0	0	0	0	0	0	0	
	△	0	0	0	0	0	0	0	1	0	0	0	0	0	0	0	1	0	0	0	0	0	0	1	
	Darker	0	0	0	0	0	0	1	0	0	0	0	0	0	0	1	0	0	0	0	0	0	0	1	
	△	↑								↑				↑											
	▽	↓								↓				↓											
	Brighter	1	1	1	1	1	1	0	1	1	1	1	1	1	0	1	1	1	1	1	1	1	1	0	1
	▽	1	1	1	1	1	1	1	0	1	1	1	1	1	1	1	0	1	1	1	1	1	1	1	0
	White	1	1	1	1	1	1	1	1	1	1	1	1	1	1	1	1	1	1	1	1	1	1	1	1

5.4 Power Sequence

5.4.1 LCD driver circuit

To prevent a latch-up or DC operation of the LCD module, the power on/off sequence shall be as shown in below

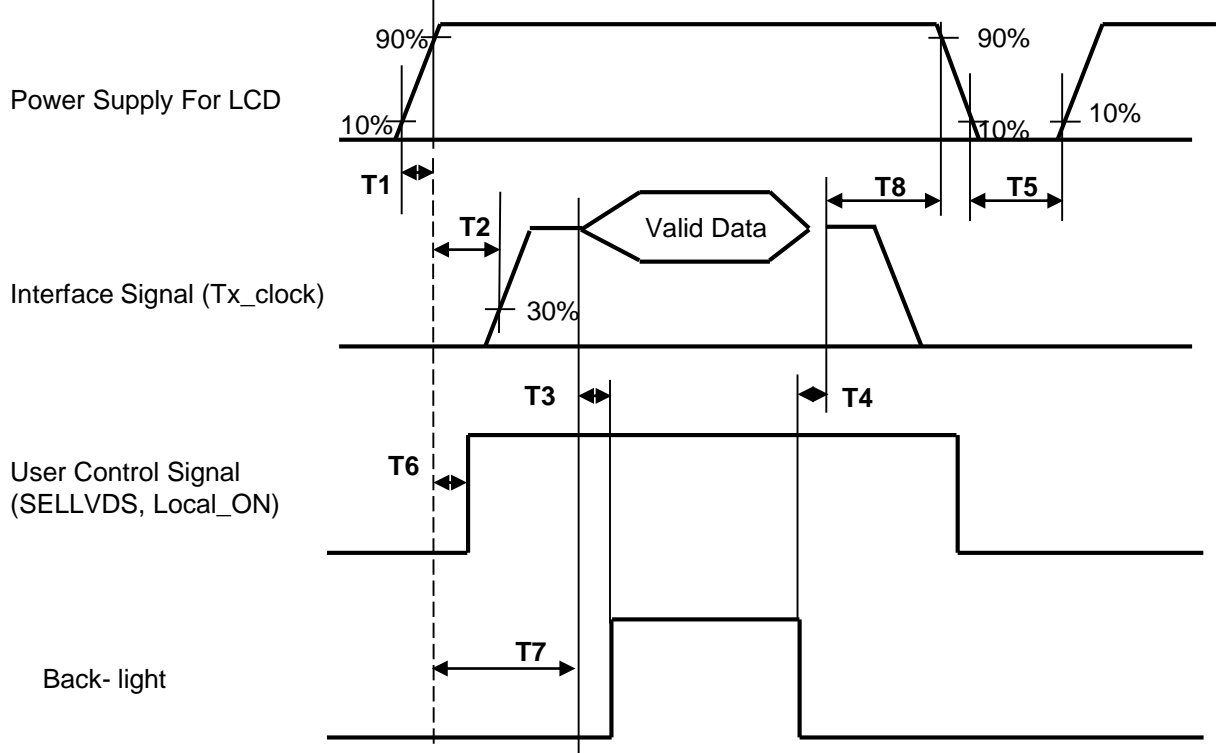

Parameter	Values			Units
	Min	Typ	Max	
T1	0.5	-	10	ms
T2	0.1	-	T7	ms
T3	400	-	-	ms
T4	200	-	-	ms
T5	5	-	-	sec
T6	0.1	-	T2	ms
T7	1	-	10	sec
T8	100	-	-	ms

Notes:

1. When the power supply VDD is 0V, keep the level of input signals on the low or keep high impedance.
2. Do not keep the interface signal high impedance when power is on.
3. Back-light must be turn on after power for logic and interface signal are valid.

5.4.2 Sequence for converter

Power supply for converter

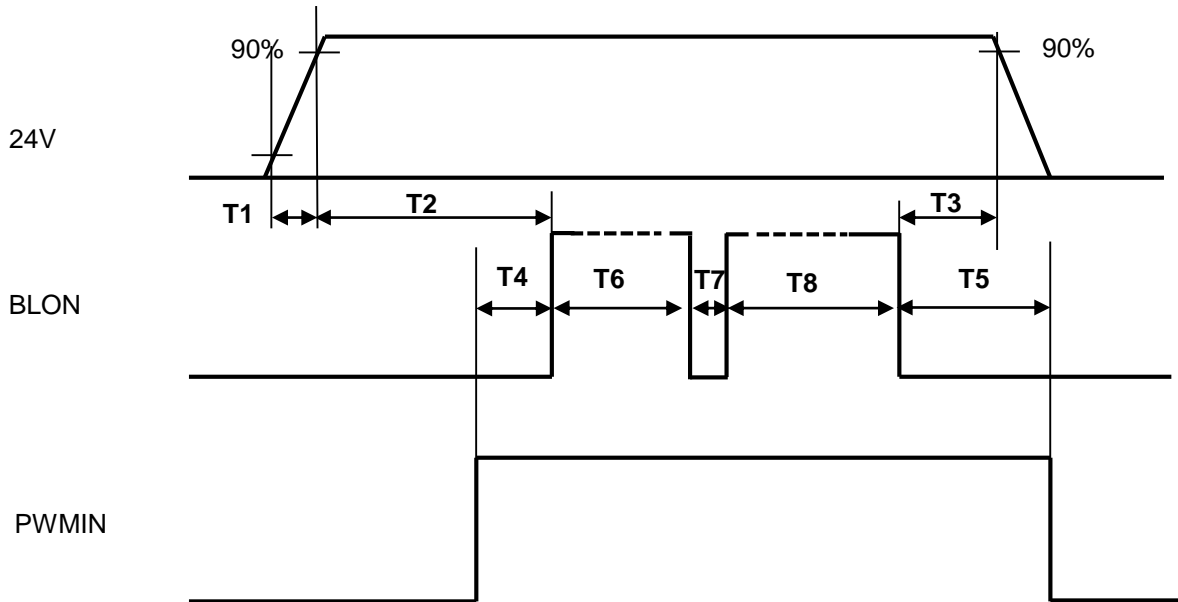

Parameter	Values			Units
	Min	Typ	Max	
T1/T3	10	-	-	ms
T2	200	-	-	ms
T4/T5	0.1	-	-	ms
T6/T8	2	-	-	sec
T7	500	-	-	ms

6.0 OPTICAL SPECIFICATIONS

The test of optical specifications shall be measured in a dark room (ambient luminance \leq 1 lux and temperature $=25\pm 2^{\circ}\text{C}$) with the equipment of Luminance meter system (Goniometer system and PR730) and test unit shall be located at an approximate distance 50cm from the LCD surface at a viewing angle of θ and Φ equal to 0° . We refer to $\theta_{\Phi=0}$ ($=\theta_3$) as the 3 o'clock direction (the "right"), $\theta_{\Phi=90}$ ($=\theta_{12}$) as the 12 o'clock direction ("upward"), $\theta_{\Phi=180}$ ($=\theta_9$) as the 9 o'clock direction ("left") and $\theta_{\Phi=270}$ ($=\theta_6$) as the 6 o'clock direction ("bottom"). While scanning θ and/or Φ , the center of the measuring spot on the Display surface shall stay fixed. The measurement shall be executed after 30 minutes warm-up period. VDD shall be 12.0V +/-10% at 25°C . Optimum viewing angle direction is 6 'clock.

< Table 11. Optical Table >

[VDD = 12.0V, Frame rate = 60Hz, Ta = $25\pm 2^{\circ}\text{C}$]

Parameter		Symbol	Condition	Min	Typ	Max	Unit	Remark
Viewing Angle	Horizontal	Θ_3	CR > 10		89		Deg.	Note 1
		Θ_9			89		Deg.	
	Vertical	Θ_{12}			89		Deg.	
		Θ_6			89		Deg.	
Contrast ratio	LD_ON	CR1		-	45000:1	-		Note 2
	LD_OFF	CR2		900:1	1200:1	-		Note 3
Chromaticity coordinate	White	W_x	$\Theta = 0^{\circ}$ (Center) Normal Viewing Angle	TYP. - 0.03	0.280	TYP. + 0.03		Note 4
		W_y			0.293			
	Red	R_x			0.629			
		R_y			0.345			
	Green	G_x			0.292			
		G_y			0.614			
	Blue	B_x			0.153			
		B_y			0.045			
Response Time	G to G	T_g		-	8	10	ms	Note 5
Color Gamut					72		%	
Gamma Scale				2.0	2.2	2.4		
Brightness				400	500		nit	
Uniformity					85		%	Note 6

Note :

1. Viewing angle is the angle at which the contrast ratio is greater than 10. The viewing are determined for the horizontal or 3, 9 o'clock direction and the vertical or 6, 12 o'clock direction with respect to the optical axis which is normal to the LCD surface.
2. Contrast measurements shall be made at viewing angle of $\theta=0^\circ$ and at the center of the LCD surface. Luminance shall be measured with all pixels in the view field set first to white, then to the dark (black) state. (See Figure 1 shown in Appendix) Luminance Contrast Ratio (CR) is defined mathematically.

$$CR = \frac{\text{Luminance when displaying a white raster}}{\text{Luminance when displaying a black raster}}$$

3. LD_ON=Local Diming enable.
LD_OFF=Local Diming disable.
4. The color chromaticity coordinates specified in Table 11. shall be calculated from the spectral data measured with all pixels first in red, green, blue and white. Measurements shall be made at the center of the panel.
5. Response time Tg is the average time required for display transition by switching the input signal as below table and is based on Frame rate fV =60Hz to optimize.
Each time in below table is defined as Figure2 and shall be measured by switching the input signal;

Measured Response Time	Target																
	0	15	31	47	63	79	95	111	127	143	159	175	191	207	223	239	255
0																	
15																	
31																	
47																	
63																	
79																	
95																	
111																	
127																	
143																	
159																	
175																	
191																	
207																	
223																	
239																	
255																	

6. Brightness Uniformity measurement shall be taken at the locations shown in Figure 3.

7.0 MECHANICAL CHARACTERISTICS

7.1 Dimensional Requirements

Table 12 provides general mechanical characteristics.

Other parameters are shown in Figure 4、 Figure 5.

< Table 12. Dimensional Parameters >

Parameter	Specification	Unit
MDL Outline	1213.5 (H) ×684.3(V)	mm
Active area	1209.6 (H) ×680.4(V)	mm
MDL Thickness	40.9	mm
Weight	15,800(Typ.)	gram

7.2 Surface treatment

The surface of the LCD has an Anti-glare coating to minimize reflection and a coating to Reduce scratching.

8.0 RELIABILITY TEST

The Reliability test items and its conditions are shown in below.

< Table 13. Reliability Test Parameters >

No	Test Items	Conditions
1	High temperature storage test	Ta = 60 °C, 240 hrs
2	Low temperature storage test	Ta = -20 °C, 240 hrs
3	High temperature & high humidity operation test	Ta = 50 °C, 80%RH, 240hrs
4	Low temperature operation test	Ta = -5 °C, 240hrs
5	High temperature operation test	Ta = 50 °C, 240hrs
6	Vibration test (non-operating)	Frequency : 5~ 200 Hz, Random Gravity / AMP : 1.05Grms Period : +Z
7	Electro-static discharge test	Air : ±15kV , 150pF/330Ω , 100Point , 1time/Point MDL Contact : ±8kV , 150pF/330Ω , 100Point , 1time/Point Pin Contact: ±5KV , 150pF/330Ω , Input connector Pin, 3 times/pin with no function loss

9.0 PRODCUT SERIAL NUMBER

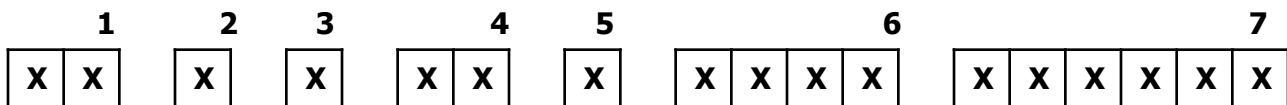

- 1. Control Number
- 2. Rank / Grade
- 3. Line Classification
- 4. Year (2011 : 11, 2012 : 12, ...)

- 5. Month (1,2,3, ... , 9, X, Y, Z)
- 6. Internal Use
- 7. Serial Number

10.0 PACKING INFORMATION

BOE provides the standard shipping container for customers, unless customer specifies their packing information. The standard packing method and Barcode information are shown in below.

10.1 Packing Order

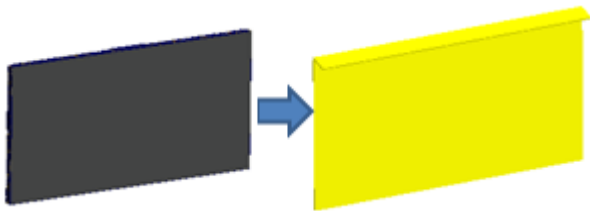

Put one Pcs into the PE Bag

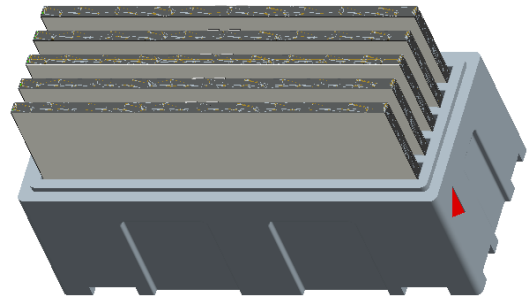

Put Five Pcs LCD MDL in the EPS BOX.

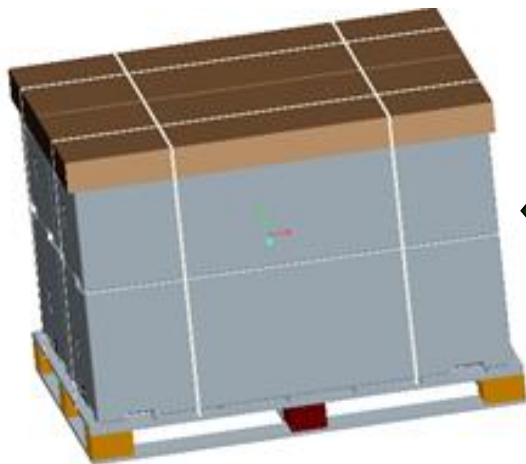

Put the Top-cover on the Box (10ea MDLs per pallet) and Pack with 4 packing belts.

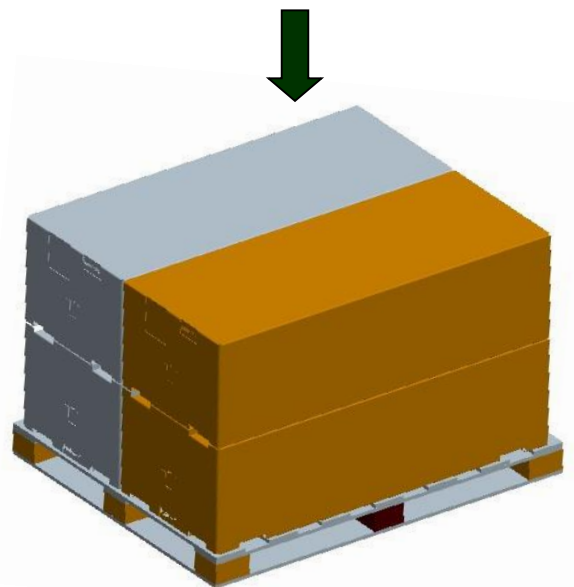

Put 2 EPS BOX on the pallet.

10.2 Packing Note

- Box Dimension : 1362mm (L) × 567mm (W) × 884.5mm (H)
- Package Quantity in one Box : 5pcs

10.3 Box Label

- Label Size : 110 mm (L) × 55 mm (W)
- Contents

Model : DV550FHM-NV8

Q`ty : Module 5 Q`ty in one box

Serial No. : Box Serial No. See next page for detail description.

Date : Packing Date

FG Code : FG Code of Product

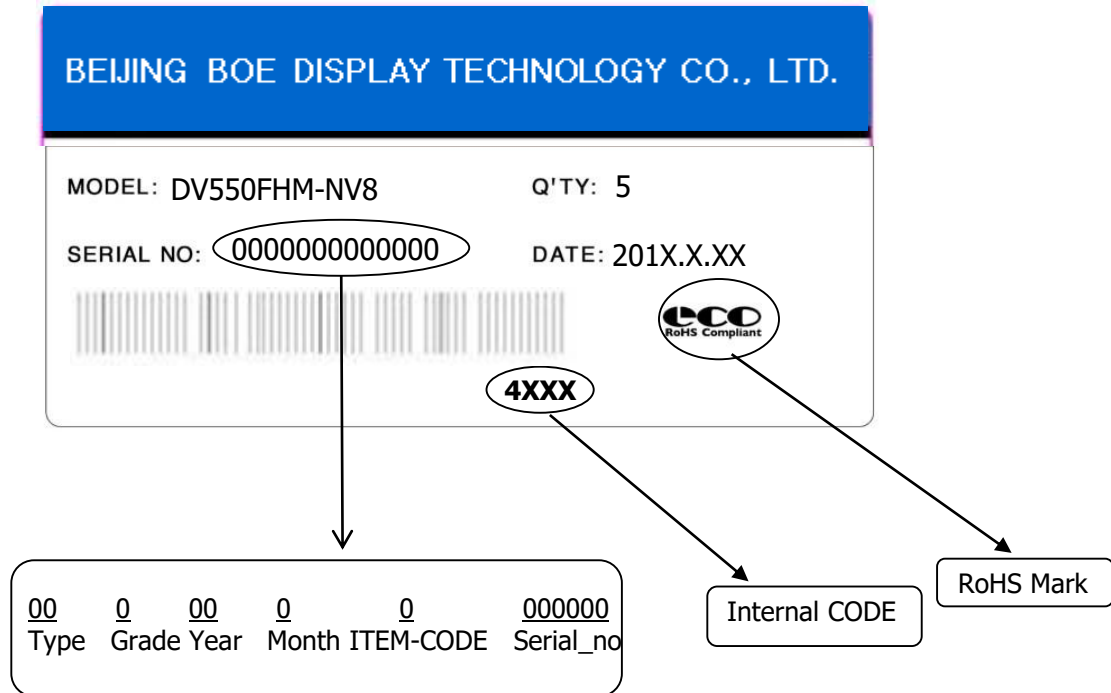

11.0 HANDLING & CAUTIONS

(1) Cautions when taking out the module

- Pick the pouch only, when taking out module from a shipping package.

(2) Cautions for handling the module

- As the electrostatic discharges may break the LCD module, handle the LCD module with care. Peel a protection sheet off from the LCD panel surface as slowly as possible.
- As the LCD panel and back - light element are made from fragile glass material, impulse and pressure to the LCD module should be avoided.
- As the surface of the polarizer is very soft and easily scratched, use a soft dry cloth without chemicals for cleaning.
- Do not pull the interface connector in or out while the LCD module is operating.
- Put the module display side down on a flat horizontal plane.
- Handle connectors and cables with care.

(3) Cautions for the operation

- When the module is operating, do not lose CLK, ENAB signals. If any one of these signals is lost, the LCD panel would be damaged.
- Obey the supply voltage sequence. If wrong sequence is applied, the module would be damaged.

(4) Cautions for the atmosphere

- Dew drop atmosphere should be avoided.
- Do not store and/or operate the LCD module in a high temperature and/or humidity atmosphere. Storage in an electro-conductive polymer packing pouch and under relatively low temperature atmosphere is recommended.

(5) Cautions for the module characteristics

- Do not apply fixed pattern data signal to the LCD module at product aging.
- Applying fixed pattern for a long time may cause image sticking.

(6) Other cautions

- Do not disassemble and/or re-assemble LCD module.
- Do not re-adjust variable resistor or switch etc.
- When returning the module for repair or etc., Please pack the module not to be broken. We recommend to use the original shipping packages.
- Static information display recommended to use with moving image. Moving image is strongly recommended as a screen save

12.0 APPENDIX

< Figure 1. Measurement Set Up >

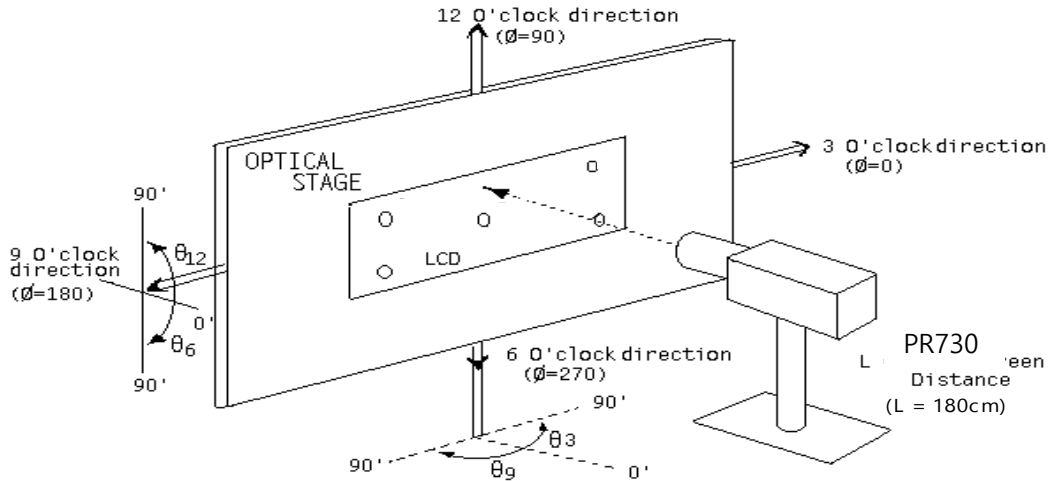

< Figure 2. Response Time Testing >

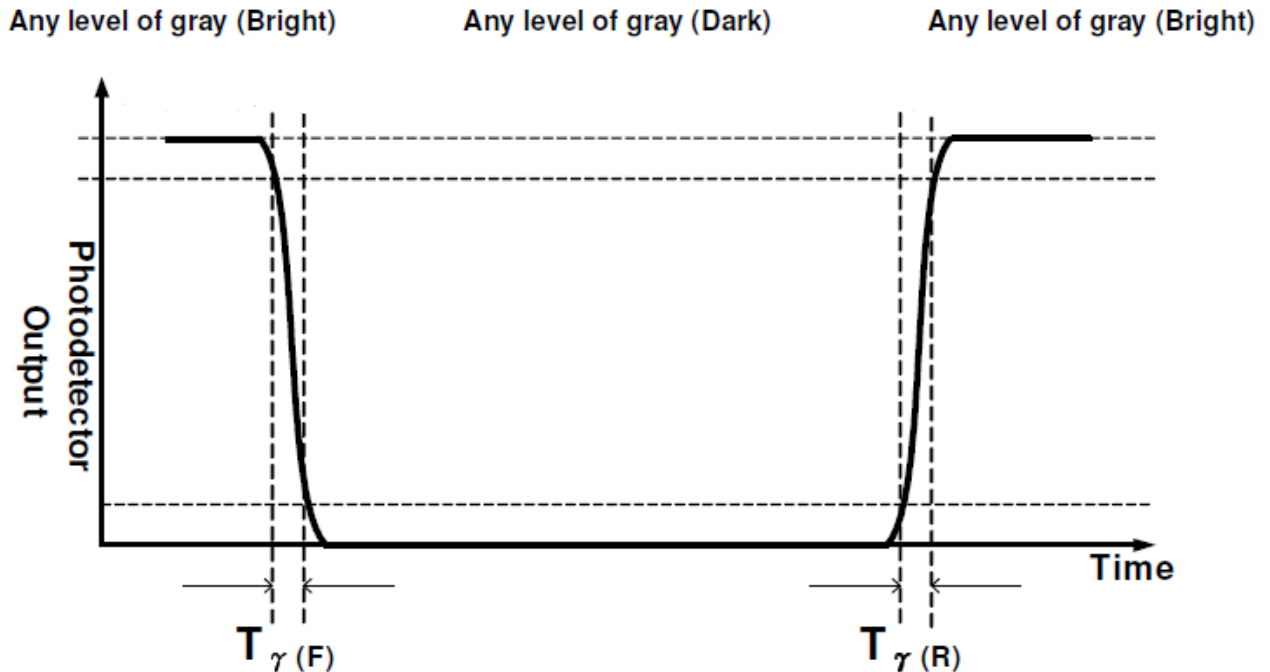

12.0 APPENDIX

< Figure 3. Uniformity Measurement Locations >

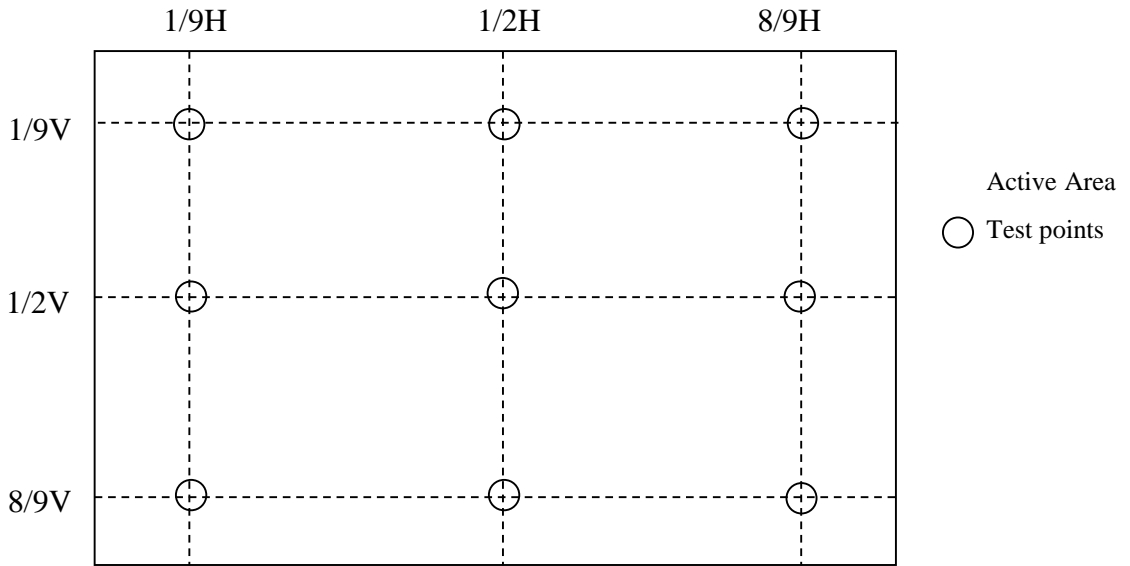
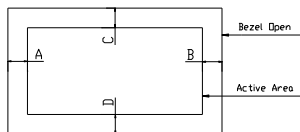
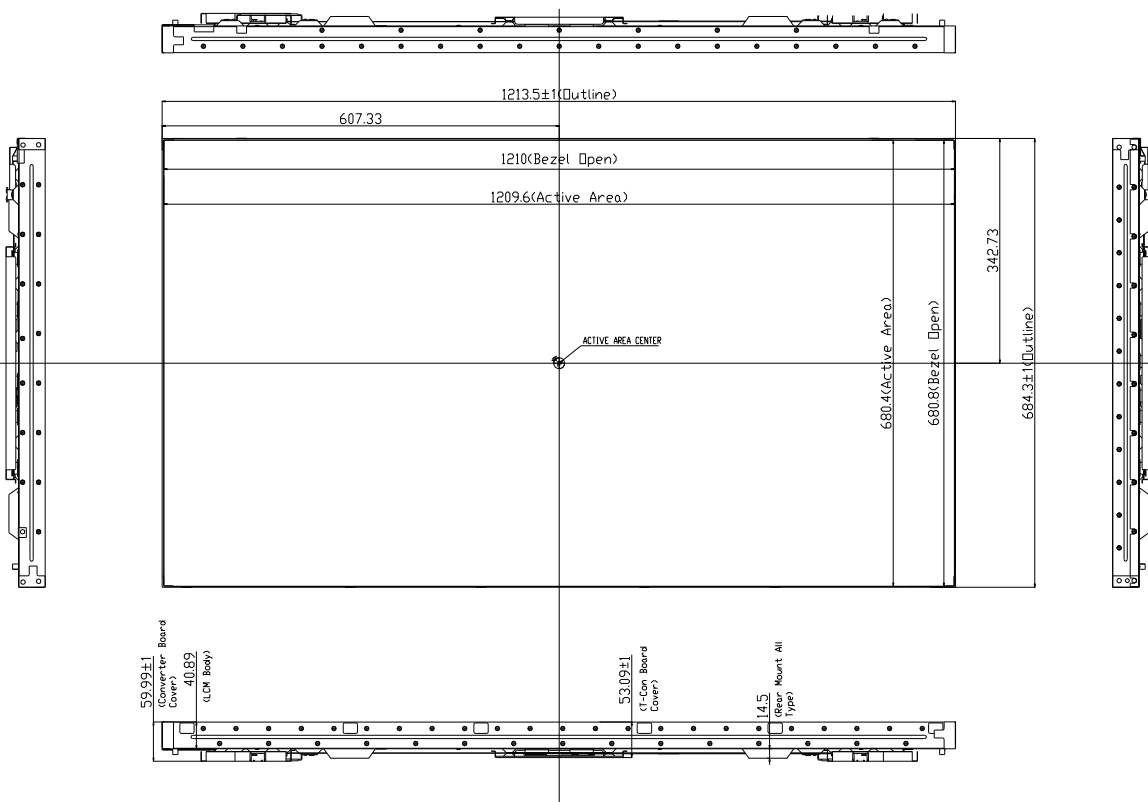

Figure 4. TFT-LCD Module Outline Dimensions (Front view)



NOTES:
 1) UNSPECIFIED DIMENSIONAL TOLERANCES TO BE ±0.5MM.
 2) TILT AND A PARTIAL DISPOSITION TOLERANCE OF DISPLAY AREA ARE AS FOLLOW.
 1) X-DIRECTION: |A-B| < 2.0MM
 2) Y-DIRECTION: |C-D| < 2.0MM

Figure 5. TFT-LCD Module Outline Dimensions (Back view)

