

Ver.	Modify No.	Details	Area	P.I.C	Date
01	01	SNT-ITO-TPB-19-ILI+ZV190E0M-N10 Optical Bonding	DWG	Curry	240628

Front View

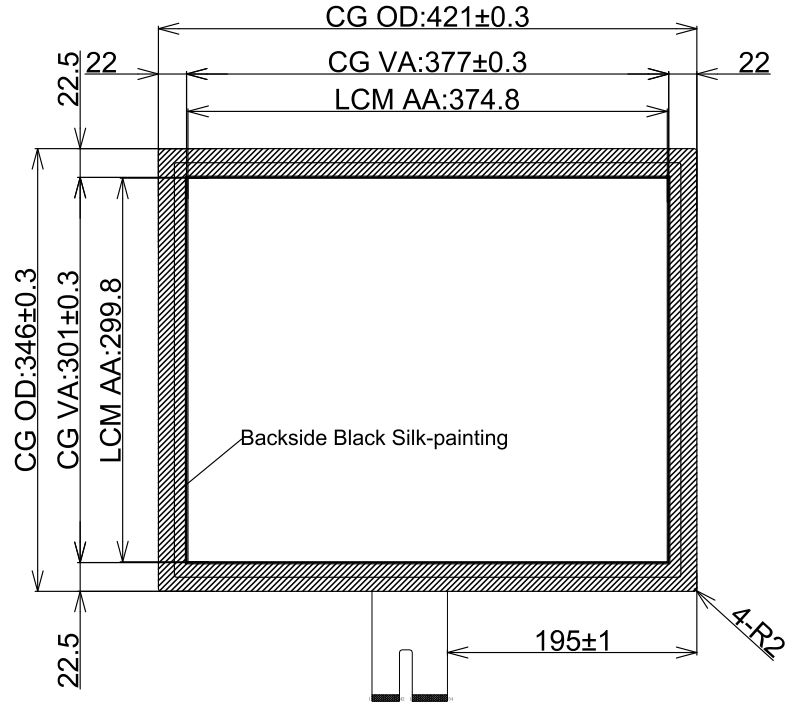

Side View

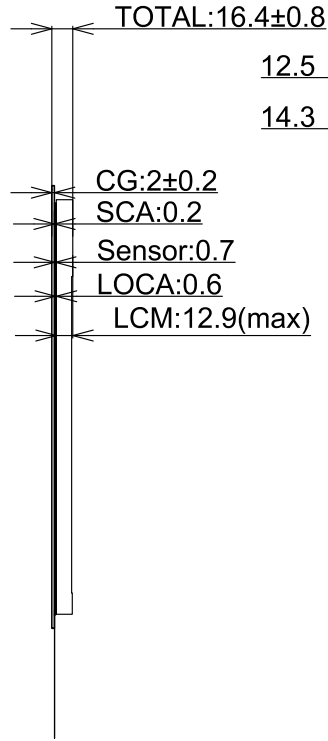

Back View

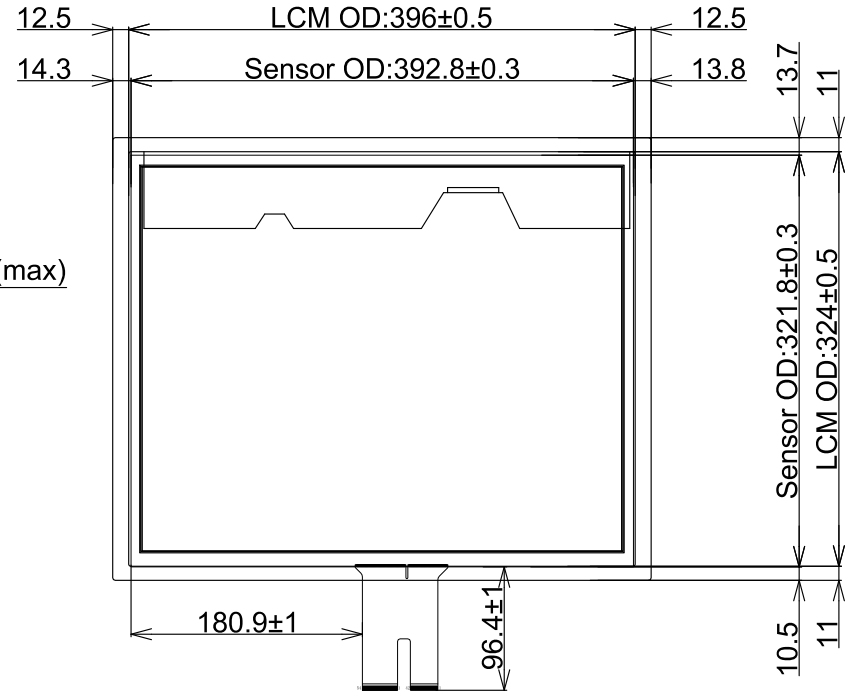

Technical Datasheet:

1. Structure: TP+LCM Optical Bonding
2. Cover Glass: 2mm Tempered Glass
3. LCD: ZV190E0M-N10
4. TP Controller: BTP-TPM-CTR-ILI-190B-SN09
5. TP Controller IC: ILI2510
6. Surface Hardness: ≥6H
7. Light Transmittance: ≥85%
8. Working Temperature: -20°C~+70°C, ≤85%RH;
9. Storage Temperature: -30°C~+80°C, ≤85%RH;
10. Unmarked Tolerance: ±0.5mm
11. All materials used conform to RoHS standards

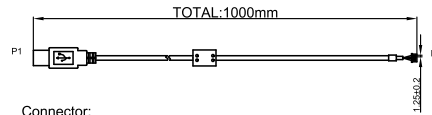
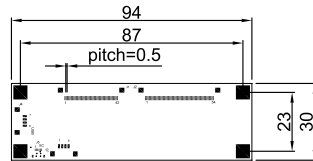

Connector:
P1:USB Male Connector
P2:1.25 Pitch 4pin Connector

Designed by:	Curry, Wang
Checked by:	Jimmy.Lu
Approved by:	Cale.Chen
Workmanship:	
Standardization:	Link.Chen
Released by:	Rocky.Liu

Part No.		BTP-TPM-ZV-19-ILI-SN09		
Product Name:		Drawing No.	PM190240628SN09	
19 inch Touch Display (TP+LCM Optical Bonding)		Project Code.	PM190SN09	
Business Unit:		Period Mark	View Angle	Ratio
SNT-BTP		A		1:1
BOM Code	2.03.190.01.0109	Page 1	Total 1 Page	
Product Series	BTP-TPM	思诺泰科创电子(苏州)有限公司 SINOTRONICS INC.		