



**PROPRIETARY NOTE**

THIS SPECIFICATION IS THE PROPERTY OF BOE DT AND SHALL NOT BE REPRODUCED OR COPIED WITHOUT THE WRITTEN PERMISSION OF BOE DT AND MUST BE RETURNED TO BOE DT UPON ITS REQUEST

**TITLE : MV236FHB-N10**

**Product Specification**

**Rev. 0**

BEIJING BOE Display TECHNOLOGY

SPEC. NUMBER S	PRODUCT GROUP TFT-LCD	Rev. A	ISSUE DATE 2015.6.05	P 1
-------------------	--------------------------	--------	-------------------------	--------



## Contents

<b>No.</b>	<b>Item</b>	<b>Page</b>
1.0	General Description	4
2.0	Absolute Maximum Ratings	6
3.0	Electrical Specifications	7
4.0	Optical Specifications	8
5.0	Interface Connection	10
6.0	Signal Timing Specifications	12
7.0	Signal Timing Waveforms of Interface Signal	14
8.0	Input Signals, Display Colors & Gray Scale of Colors	16
9.0	Power Sequence	17
10.0	Mechanical Characteristics	18
11.0	Reliability Test	19
12.0	Handling & Cautions	20
13.0	Product Serial Number	21
14.0	Packing	22
15.0	Appendix	24

<b>BOE</b>	<b>PRODUCT GROUP</b>	REV	ISSUE DATE
	Customer SPEC	Rev. 0	Jun.05.2015

## 1.0 GENERAL DESCRIPTION

### 1.1 Introduction

MV236FHB-N10 is a color active matrix TFT LCD open cell using amorphous silicon TFT's (Thin Film Transistors) as an active switching devices. This open cell has a 23.6 inch diagonally measured active area with FHD resolutions (1920 horizontal by 1080 vertical pixel array). Each pixel is divided into RED, GREEN, BLUE dots which are arranged in vertical stripe and this open cell can display 16.7M colors. The TFT-LCD panel used for this open cell is adapted for a low reflection and higher color type.

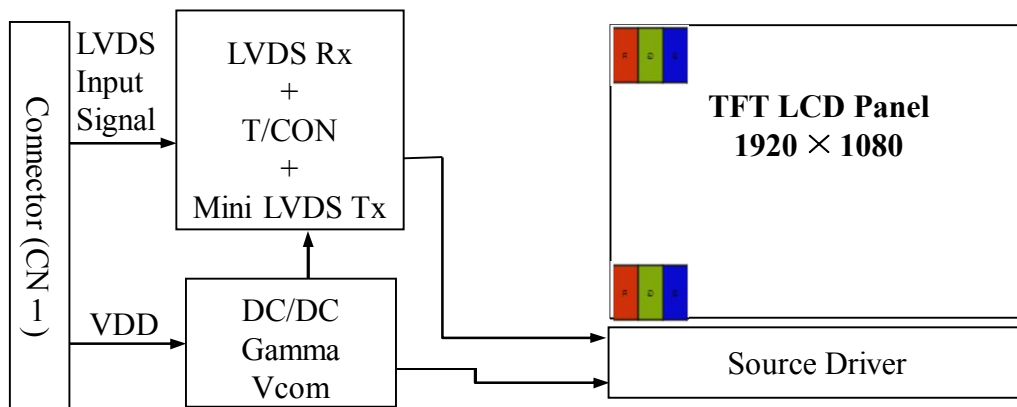

### 1.2 Features

- LVDS Interface with 2 pixel / clock
- High-speed response
- 6-bit (Hi-FRC) color depth, display 16.7M colors
- Incorporated edge type back-light (LED)
  - High luminance and contrast ratio, low reflection and wide viewing angle
- DE (Data Enable) only
- RoHS/Halogen Free
- TCO 6.0 , ES 6.0 compliant
- Gamma Correction
- Reverse type

SPEC. NUMBER S	SPEC. TITLE MV236FHB-N10 Product Specification Rev. 0	P 4
-------------------	--	--------

<b>BOE</b>	<b>PRODUCT GROUP</b>	REV	ISSUE DATE
	Customer SPEC	Rev. 0	Jun.05.2015

### 1.3 Application

- Desktop Type of PC & Workstation Use
- Slim-Size Display for Stand-alone Monitor
- Display Terminals for Control System
- Monitors for Process Controller

### 1.4 General Specification

The followings are general specifications at the model MV236FHB-N10.

<Table 1. General Specifications>

Parameter	Specification	Unit	Remarks
Active area	521.28(H) x293.22(V)	mm	
Number of pixels	1920(H) × 1080(V)	pixels	
Pixel pitch	0.2715(H) x 0.2715(V)	mm	
Pixel arrangement	RGB Vertical stripe		
Display colors	16.7M	colors	
Display mode	Normally Black		
Open Cell Transmittance	5.3	%	
Weight (typ)	490	gram	
Power Consumption	3.6(@ Mosaic Pattern)	Watt	
Surface Treatment	Haze 25%, 3H		

SPEC. NUMBER S	SPEC. TITLE MV236FHB-N10 Product Specification Rev. 0	P 5
-------------------	--	--------

### 2.0 ABSOLUTE MAXIMUM RATINGS

The followings are maximum values which, if exceed, may cause faulty operation or damage to the unit. The operational and non-operational maximum voltage and current values are listed in Table 2.

< Table 2. Absolute Maximum Ratings> [VSS=GND=0V]

Parameter	Symbol	Min.	Max.	Unit	Remarks
Power Supply Voltage	$V_{DD}$	-0.3	5.5	V	Ta = 25 °C
Logic Supply Voltage	$V_{IN}$	VSS-0.3	$V_{DD}+0.3$	V	
Operating Temperature	$T_{OP}$	0	+50	°C	1)
Storage Temperature	$T_{ST}$	-20	+60	°C	1)

Note : 1) Temperature and relative humidity range are shown in the figure below.  
Wet bulb temperature should be 39 °C max. and no condensation of water.

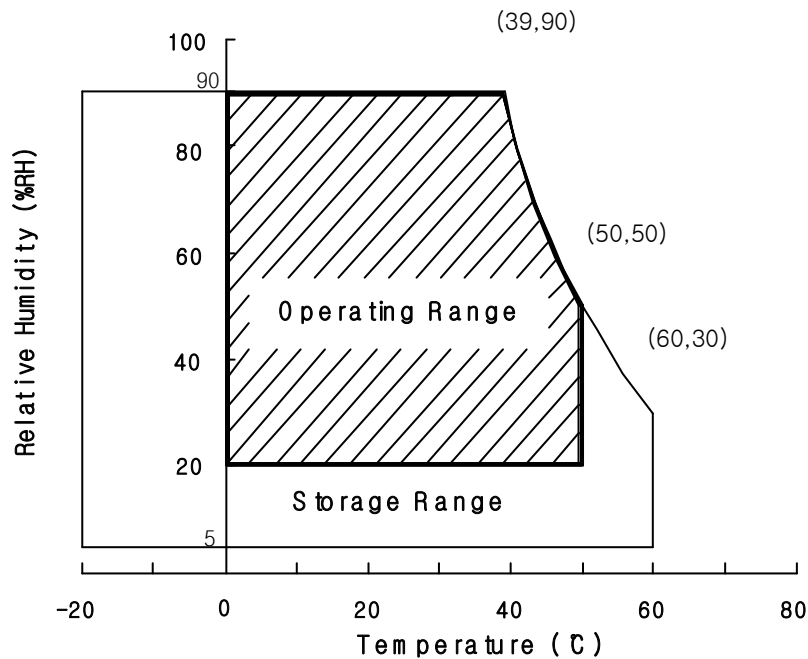

SPEC. NUMBER S	SPEC. TITLE MV236FHB-N10 Product Specification Rev. 0	P 6
-------------------	--	--------

**3.0 ELECTRICAL SPECIFICATIONS****3.1 Electrical Specifications**

&lt; Table 3. Electrical specifications &gt;

[Ta =25 ± 2 °C]

Parameter		Min.	Typ.	Max.	Unit	Remarks
Power Supply Voltage	V <sub>DD</sub>	4.5	5.0	5.5	V	Note1
Power Supply Current	I <sub>DD</sub>	-	TBD	TBD	mA	
In-Rush Current	I <sub>RUSH</sub>	-	-	5.0	A	Note 2
Permissible Input Ripple Voltage	V <sub>RF</sub>	-	-	300	mV	Note1,3
High Level Differential Input Threshold Voltage	V <sub>IH</sub>	-	-	+100	mV	
Low Level Differential Input Threshold Voltage	V <sub>IL</sub>	-100	-	-	mV	
Differential input voltage	V <sub>ID</sub>	200	-	600	mV	
Differential input common mode voltage	V <sub>cm</sub>	1.0	1.2	1.5		V <sub>IH</sub> =100mV, V <sub>IL</sub> =-100mV
Power Consumption	P <sub>D</sub>	-	3.6	-	W	
	P <sub>BL</sub>	-	-	-	W	
	P <sub>total</sub>	-	-	-	W	

Notes : 1. The supply voltage is measured and specified at the interface connector of LCM.  
The current draw and power consumption specified is for VDD=5.0V, Frame rate=60Hz  
Clock frequency = 92.9 MHz. Test Pattern of power supply current  
a) Typ : Mosaic Pattern

2. Duration of rush current is about 2 ms and rising time of VDD is 520 μs ± 20 %  
3. Ripple Voltage should be covered by Input voltage Spec.

SPEC. NUMBER  
S

SPEC. TITLE  
MV236FHB-N10 Product Specification Rev. 0

P  
7

## 4.0 OPTICAL SPECIFICATION

### 4.1 Overview

The test of Optical specifications shall be measured in a dark room (ambient luminance = 1 lux and temperature =  $25 \pm 2^\circ\text{C}$ ) with the equipment of Luminance meter system (Goniometer system and **TOPCONE PR730**) and test unit shall be located at an approximate distance 50cm from the LCD surface at a viewing angle of  $\theta$  and  $\Phi$  equal to  $0^\circ$ . We refer to  $\theta_{0=0}$  ( $=\theta_3$ ) as the 3 o'clock direction (the "right"),  $\theta_{0=90}$  ( $=\theta_{12}$ ) as the 12 o'clock direction ("upward"),  $\theta_{0=180}$  ( $=\theta_9$ ) as the 9 o'clock direction ("left") and  $\theta_{0=270}$  ( $=\theta_6$ ) as the 6 o'clock direction ("bottom"). While scanning  $\theta$  and/or  $\Phi$ , the center of the measuring spot on the Display surface shall stay fixed. The measurement shall be executed after 30 minutes warm-up period. VDD shall be 5.0V +/-10% at  $25^\circ\text{C}$ . Optimum viewing angle direction is 6 o'clock.

### 4.2 Optical Specifications

[VDD = 5.0V, Frame rate = 60Hz, Clock = 74.25MHz,  $T_a = 25 \pm 2^\circ\text{C}$ ]

< Table 4. Module Optical >

Parameter		Symbol	Condition	Min.	Typ.	Max.	Unit	Remark
Viewing Angle range	Horizontal	$\Theta_3$	CR > 10	80	89	-	Deg.	Note 1
		$\Theta_9$		80	89	-	Deg.	
	Vertical	$\Theta_{12}$		80	89	-	Deg.	
		$\Theta_6$		80	89	-	Deg.	
Luminance Contrast ratio		CR		700	1000			Note 2
Transmittance		Tr		5.0	5.3	-		
Luminance of White		$Y_w$	$\Theta = 0^\circ$ (Center) Normal Viewing Angle	200	250		cd/m <sup>2</sup>	Note 3
White luminance uniformity		$\Delta Y$		75	-		%	Note 4
Reproduction of color	White	$W_x$		-0.03	+0.03	0.313	-	Note 5
		$W_y$				0.329	-	
	Red	$R_x$				0.641	-	
		$R_y$				0.334	-	
	Green	$G_x$				0.318	-	
		$G_y$				0.639	-	
	Blue	$B_x$				0.154	-	
		$B_y$				0.066	-	
Response Time	GTG	$T_g$		14	20	ms	Note 6	
Cross Talk		CT		-	-	2.0	%	Note 8

<b>BOE</b>	PRODUCT GROUP	REV	ISSUE DATE
	Customer SPEC	Rev. 0	Jun.05.2015

**Note :**

1. Viewing angle is the angle at which the contrast ratio is greater than 10. The viewing are determined for the horizontal or 3, 9 o'clock direction and the vertical or 6, 12 o'clock direction with respect to the optical axis which is normal to the LCD surface.
2. Contrast measurements shall be made at viewing angle of  $\theta = 0^\circ$  and at the center of the LCD surface. Luminance shall be measured with all pixels in the view field set first to white, then to the dark (black) state. Luminance Contrast Ratio (CR) is defined mathematically.

$$CR = \frac{\text{Luminance when displaying a white raster}}{\text{Luminance when displaying a black raster}}$$

3. Center Luminance of white is defined as the LCD surface. Luminance shall be measured with all pixels in the view field set first to white. This measurement shall be taken at the locations shown in FIGURE 2 for a total of the measurements per display.
4. The White luminance uniformity on LCD surface is then expressed as :  
 $\Delta Y = ( \text{Minimum Luminance of 9points} / \text{Maximum Luminance of 9points} ) * 100$
5. The color chromaticity coordinates specified in Table 4. shall be calculated from the spectral data measured with all pixels first in red, green, blue and white. Measurements shall be made at the center of the panel.
6. Response time Tg is the average time required for display transition by switching the input signal as below table and is based on Frame rate fV =60Hz to optimize.  
Each time in below table is defined as appendix Figure 3 and shall be measured by switching the input signal for “any level of gray(bright)”and “any level of gray(dark)”
7. Flicker value is measured at the LCD surface at flicker pattern. And flicker pattern is different with different driving method. (The Flicker pattern of z-inversion is the 1V1H at Green status)

a.) Test Pattern : It is listed as following.

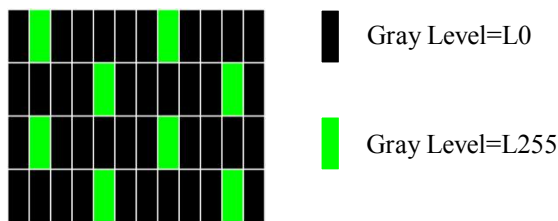

b.) Measured Position: Center of screen & perpendicular to the screen

SPEC. NUMBER S	SPEC. TITLE MV236FHB-N10 Product Specification Rev. 0	P 9
-------------------	--	--------

<b>BOE</b>	<b>PRODUCT GROUP</b>	REV	ISSUE DATE
	Customer SPEC	Rev. 0	Jun.05.2015

8. Cross-Talk of one area of the LCD surface by another shall be measured by comparing the luminance (YA) of a 25mm diameter area, with all display pixels set to a gray level, to the luminance (YB) of that same area when any adjacent area is driven dark.

SPEC. NUMBER S	SPEC. TITLE MV236FHB-N10 Product Specification Rev. 0	P 10
-------------------	--	---------

## 5.0 INTERFACE CONNECTION.

### 5.1 Electrical Interface Connection

- CN11 Module Side Connector : UJU IS100-L30R-C23or Equivalent  
User Side Connector : JAE FI-X30H or Equivalent

Pin No	Symbol	Function	Remark
1	RX00-	Negative Transmission data of Pixel 0 (ODD)	
2	RX00+	Positive Transmission data of Pixel 0 (ODD)	
3	RX01-	Negative Transmission data of Pixel 1 (ODD)	
4	RX01+	Positive Transmission data of Pixel 1 (ODD)	
5	RX02-	Negative Transmission data of Pixel 2 (ODD)	
6	RX02+	Positive Transmission data of Pixel 2 (ODD)	
7	GND	Ground	
8	RXOC-	Negative Transmission Clock (ODD)	
9	RXOC+	Positive Transmission Clock (ODD)	
10	RX03-	Negative Transmission data of Pixel 3 (ODD)	
11	RX03+	Positive Transmission data of Pixel 3 (ODD)	
12	RXE0-	Negative Transmission data of Pixel 0 (EVEN)	
13	RXE0+	Positive Transmission data of Pixel 0 (EVEN)	
14	GND	Ground	
15	RXE1-	Negative Transmission data of Pixel 1 (EVEN)	
16	RXE1+	Positive Transmission data of Pixel 1 (EVEN)	
17	GND	Ground	
18	RXE2-	Negative Transmission data of Pixel 2 (EVEN)	
19	RXE2+	Positive Transmission data of Pixel 2 (EVEN)	
20	RXEC-	Negative Transmission Clock (EVEN)	
21	RXEC+	Positive Transmission Clock (EVEN)	
22	RXE3-	Negative Transmission data of Pixel 3 (EVEN)	
23	RXE3+	Positive Transmission data of Pixel 3 (EVEN)	
24	GND	Ground	Note 1
25	CE	Internal Use	DVR
26	CTL	Internal Use	DVR
27	NC		
28	VDD	Power Supply: +5V	
29	VDD		
30	VDD		

Note 1 : This pin should be connected with GND.

### 5.2 LVDS Interface (Tx; THC63LVDF83A or Equivalent)

#### 5.2.1 LVDS Interface

	Input Signal	Transmitter		Interface		MV236FHB-N10 (CN11)	Remark
		Pin No.	Pin No.	System (Tx)	TFT-LCD (Rx)	Pin No.	
L V D S	OR0	51	48 47	OUT0- OUT0+	RXO0- RXO0+	1 2	
	OR1	52					
	OR2	54					
	OR3	55					
	OR4	56					
	OR5	3					
	OG0	4	46 45	OUT1- OUT1+	RXO1- RXO1+	3 4	
	OG1	6					
	OG2	7					
	OG3	11					
	OG4	12					
	OG5	14					
	OB0	15	42 41	OUT2- OUT2+	RXO2- RXO2+	5 6	
	OB1	19					
	OB2	20					
	OB3	22					
	OB4	23					
	OB5	24					
	Hsync	27	40 39	CLK	RXO	8 9	
	Vsync	28					
DE	30	40 39	OUT- CLK	CLK- RXO	8 9		
MCLK	31						
OR6	50	38 37	OUT+ OUT3- OUT3+	CLK+ RXO3- RXO3+	10 11		
OR7	2						
OG6	8						
OG7	10						
OB6	16						
OB7	18						
RSVD	25						

## 6.0 SIGNAL TIMING SPECIFICATION

6.1 The MV236FHB-N10 is operated by the DE only.

Item	Symbols		Min	Typ	Max	Unit	Note
DCLK	Period	tCLK	11.5	14.9	18.7	ns	
	Frequency	-	53.6	67.3	87.2	MHz	
Hsync	Period	tHP	990	1010	1040	tCLK	
	Horizontal Valid	tHV	960	960	960	tCLK	
	Frequency	fH	48.5	60.6	78	KHz	
Vsync	Period	tVP	972	1111	1250	tHP	
	Vertical Valid	tVV	1080	1080	1080	tHP	
	Frequency	fV	49	60	75	Hz	
DE (Data Enable)	DE Setup Time	tSI	4	-	-	ns	For DCLK
	DE Hold Time	tHI	4	-	-	ns	
Data	Data Setup Time	tSD	4	-	-	ns	For DCLK
	Data Hold Time	tHD	4	-	-	ns	
LVDS Receiver clock	Input spread spectrum ratio	SSr	-3	-	3	%	

Note: Hsync period and Hsync width-active should be even number times of tCLK. If the value is odd number times of tCLK, display control signal can be asynchronous. In order to operate this LCM a Hsync, Vsyn, and DE (data enable) signals should be used.

1. The performance of the electro-optical characteristics may be influenced by variance of the vertical refresh rates.
2. Vsync and Hsync should be keep the above specification.
3. Hsync Period, Hsync Width, and Horizontal Back Porch should be any times of character number (4).
4. The polarity of Hsync, Vsync is not restricted.
5. The Max frequency of 1920X1080 resolution is 82.5Mhz

SPEC. NUMBER S	SPEC. TITLE MV236FHB-N10 Product Specification Rev. 0	P 13
-------------------	--	---------

### 6.2 LVDS Rx Interface Timing Parameter

The specification of the LVDS Rx interface timing parameter is shown in Table 5.

<Table 5. LVDS Rx Interface Timing Specification>

Item	Symbol	Min	Typ	Max	Unit	Remark
CLKIN Period	tRCIP	11.5	14.9	18.7	nsec	
Input Data 0	tRIP1	-0.4	0.0	+0.4	nsec	
Input Data 1	tRIP0	tRCIP/7-0.4	tRCIP/7	tRCIP/7+0.4	nsec	
Input Data 2	tRIP6	2 × tRCIP/7-0.4	2 × tRCIP/7	2 × tRCIP/7+0.4	nsec	
Input Data 3	tRIP5	3 × tRCIP/7-0.4	3 × tRCIP/7	3 × tRCIP/7+0.4	nsec	
Input Data 4	tRIP4	4 × tRCIP/7-0.4	4 × tRCIP/7	4 × tRCIP/7+0.4	nsec	
Input Data 5	tRIP3	5 × tRCIP/7-0.4	5 × tRCIP/7	5 × tRCIP/7+0.4	nsec	
Input Data 6	tRIP2	6 × tRCIP/7-0.4	6 × tRCIP/7	6 × tRCIP/7+0.4	nsec	

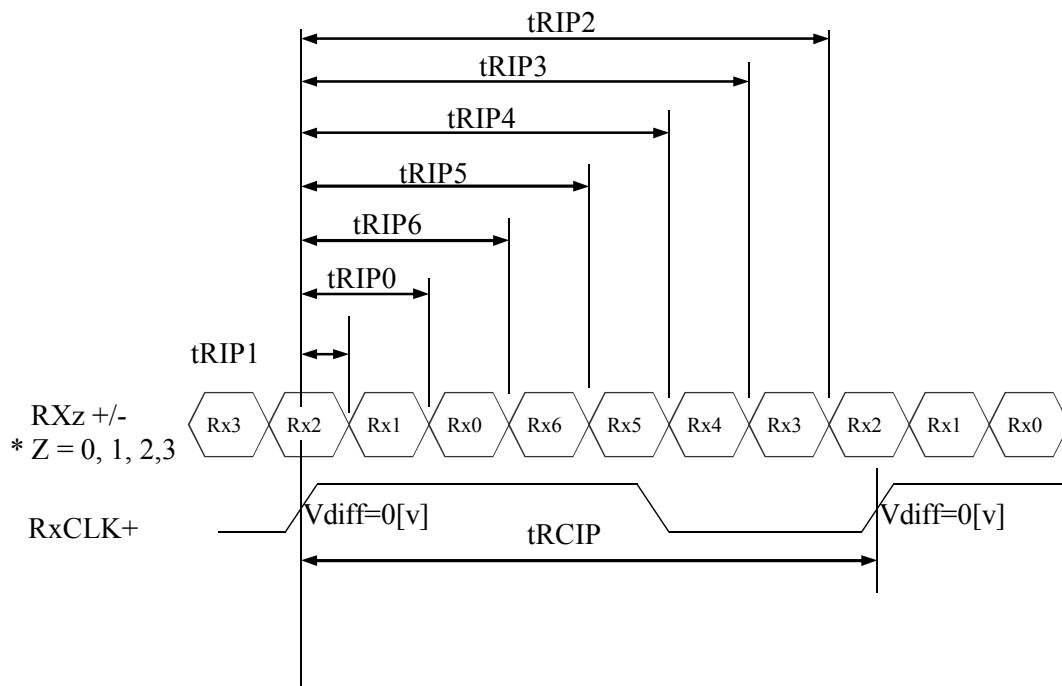

\*  $V_{diff} = (RXz+) - (RXz-), \dots, (RXCLK+) - (RXCLK-)$

SPEC. NUMBER S	SPEC. TITLE MV236FHB-N10 Product Specification Rev. 0	P 14
-------------------	--	---------

## 7.0 SIGNAL TIMING WAVEFORMS OF INTERFACE SIGNAL

### 7.1 Sync Timing Waveforms

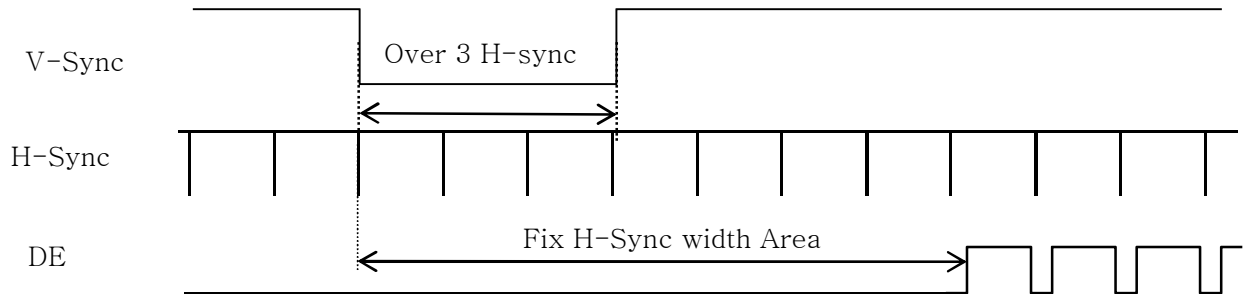

- 1) Need over 3 H-sync during V-Sync Low
- 2) Fix H-Sync width from V-Sync falling edge to first rising edge

### 7.2 Vertical Timing Waveforms

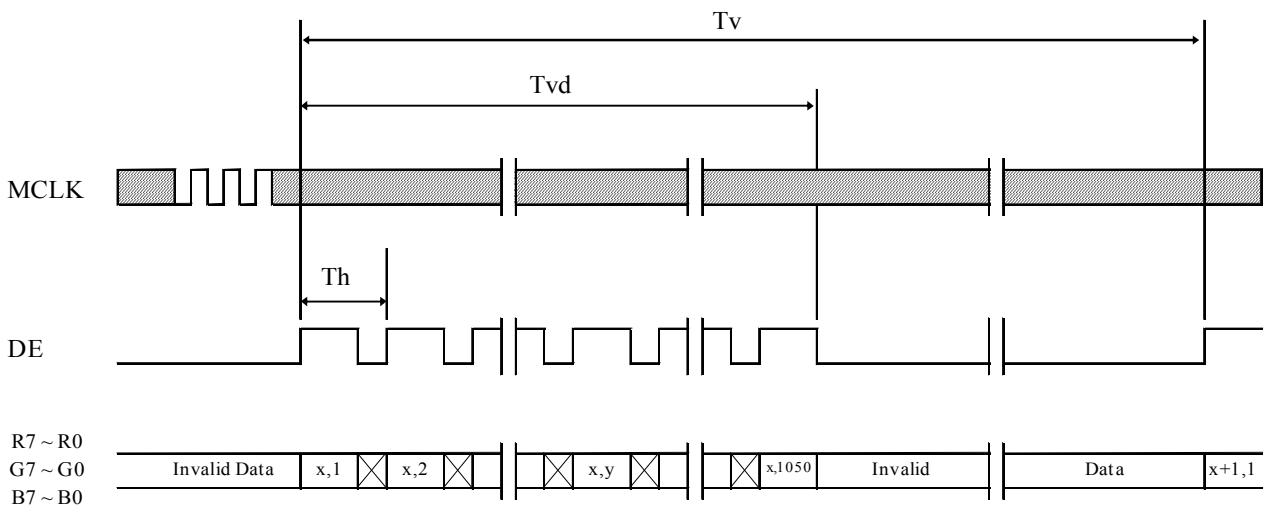

### 7.3 Horizontal Timing Waveforms

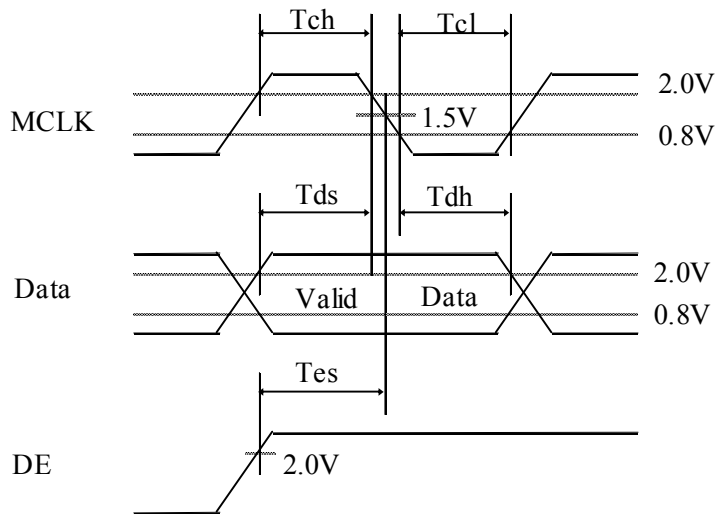
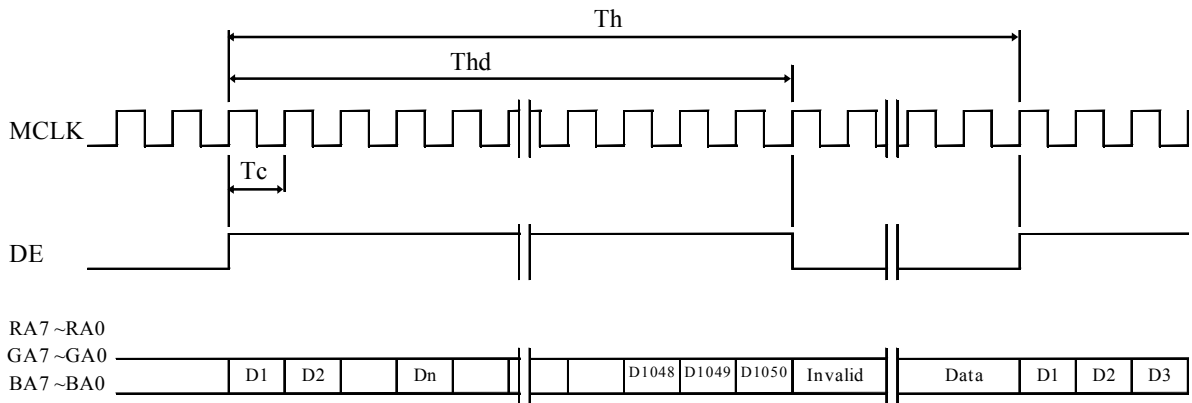

## 8.0 INPUT SIGNALS, BASIC DISPLAY COLORS & GRAY SCALE OF COLORS

Color & Gray Scale		RED DATA								GREEN DATA								BLUE DATA							
		R7	R6	R5	R4	R3	R2	R1	R0	G7	G6	G5	G4	G3	G2	G1	G0	B7	B6	B5	B4	B3	B2	B1	B0
Basic Colors	Black	0	0	0	0	0	0	0	0	0	0	0	0	0	0	0	0	0	0	0	0	0	0	0	0
	Blue	0	0	0	0	0	0	0	0	0	0	0	0	0	0	0	0	1	1	1	1	1	1	1	1
	Green	0	0	0	0	0	0	0	0	1	1	1	1	1	1	1	1	0	0	0	0	0	0	0	0
	Cyan	0	0	0	0	0	0	0	0	1	1	1	1	1	1	1	1	1	1	1	1	1	1	1	1
	Red	1	1	1	1	1	1	1	1	0	0	0	0	0	0	0	0	0	0	0	0	0	0	0	0
	Magenta	1	1	1	1	1	1	1	1	0	0	0	0	0	0	0	0	1	1	1	1	1	1	1	1
	Yellow	1	1	1	1	1	1	1	1	1	1	1	1	1	1	1	1	0	0	0	0	0	0	0	0
	White	1	1	1	1	1	1	1	1	1	1	1	1	1	1	1	1	1	1	1	1	1	1	1	1
Gray Scale of RED	Black	0	0	0	0	0	0	0	0	0	0	0	0	0	0	0	0	0	0	0	0	0	0	0	
	△	0	0	0	0	0	0	1	0	0	0	0	0	0	0	0	0	0	0	0	0	0	0	0	
	Darker	0	0	0	0	0	0	1	0	0	0	0	0	0	0	0	0	0	0	0	0	0	0	0	
	△	↑								↑															
	▽	↓								↓															
	Brighter	1	1	1	1	1	1	0	1	0	0	0	0	0	0	0	0	0	0	0	0	0	0	0	
	▽	1	1	1	1	1	1	0	0	0	0	0	0	0	0	0	0	0	0	0	0	0	0	0	
	Red	1	1	1	1	1	1	1	0	0	0	0	0	0	0	0	0	0	0	0	0	0	0	0	
Gray Scale of GREEN	Black	0	0	0	0	0	0	0	0	0	0	0	0	0	0	0	0	0	0	0	0	0	0	0	
	△	0	0	0	0	0	0	0	0	0	0	0	0	0	0	1	0	0	0	0	0	0	0	0	
	Darker	0	0	0	0	0	0	0	0	0	0	0	0	0	1	0	0	0	0	0	0	0	0	0	
	△	↑								↑															
	▽	↓								↓															
	Brighter	0	0	0	0	0	0	0	1	1	1	1	1	1	0	1	0	0	0	0	0	0	0	0	
	▽	0	0	0	0	0	0	0	1	1	1	1	1	1	0	0	0	0	0	0	0	0	0	0	
	Green	0	0	0	0	0	0	0	1	1	1	1	1	1	1	1	0	0	0	0	0	0	0	0	
Gray Scale of BLUE	Black	0	0	0	0	0	0	0	0	0	0	0	0	0	0	0	0	0	0	0	0	0	0	0	
	△	0	0	0	0	0	0	0	0	0	0	0	0	0	0	0	0	0	0	0	0	0	0	1	
	Darker	0	0	0	0	0	0	0	0	0	0	0	0	0	0	0	0	0	0	0	0	0	1	0	
	△	↑								↑															
	▽	↓								↓															
	Brighter	0	0	0	0	0	0	0	0	0	0	0	0	0	0	0	1	1	1	1	1	1	0	1	
	▽	0	0	0	0	0	0	0	0	0	0	0	0	0	0	0	1	1	1	1	1	1	1	0	
	Blue	0	0	0	0	0	0	0	0	0	0	0	0	0	0	0	1	1	1	1	1	1	1	1	
Gray Scale of WHITE	Black	0	0	0	0	0	0	0	0	0	0	0	0	0	0	0	0	0	0	0	0	0	0	0	
	△	0	0	0	0	0	0	1	0	0	0	0	0	0	0	1	0	0	0	0	0	0	0	1	
	Darker	0	0	0	0	0	0	1	0	0	0	0	0	0	1	0	0	0	0	0	0	0	1	0	
	△	↑								↑															
	▽	↓								↓															
	Brighter	1	1	1	1	1	1	0	1	1	1	1	1	1	0	1	1	1	1	1	1	1	0	1	
	▽	1	1	1	1	1	1	0	1	1	1	1	1	1	0	1	1	1	1	1	1	1	1	0	
	White	1	1	1	1	1	1	1	1	1	1	1	1	1	1	1	1	1	1	1	1	1	1	1	

### 9.0 POWER SEQUENCE

To prevent a latch-up or DC operation of the LCD module, the power on/off sequence shall be as shown in below

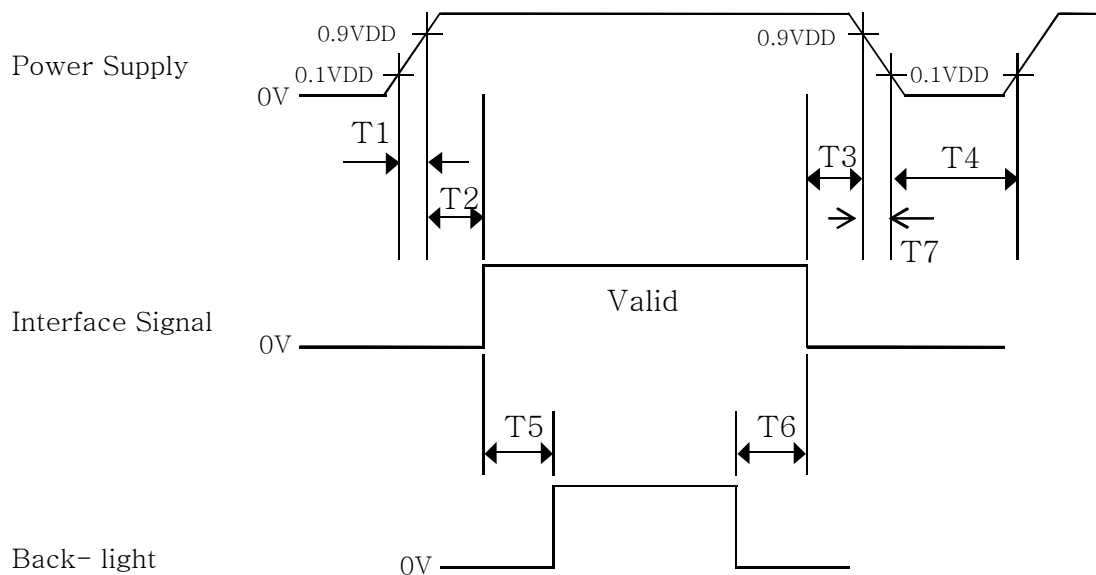

- $0.5 \text{ ms} \leq T1 \leq 10 \text{ ms}$
- $0 \leq T2 \leq 50 \text{ ms}$
- $0 \leq T3 \leq 50 \text{ ms}$
- $1 \text{ sec} \leq T4$
- $200 \text{ ms} \leq T5$
- $200 \text{ ms} \leq T6$

#### Notes:

1. When the power supply VDD is 0V, keep the level of input signals on the low or keep high impedance.
2. Do not keep the interface signal high impedance when power is on.
3. Back Light must be turn on after power for logic and interface signal are valid.
4. T7 decreases smoothly, there is none re-bouncing voltage.

<b>BOE</b>	<b>PRODUCT GROUP</b>	REV	ISSUE DATE
	Customer SPEC	Rev. 0	Jun.05.2015

## 10.0 MECHANICAL CHARACTERISTICS

### 10.1 Dimensional Requirements

FIGURE 6 (located in Appendix) shows mechanical outlines for the model MV236FHB-N10. Other parameters are shown in Table 6.

<Table 6. Dimensional Parameters>

Parameter	Specification	Unit
Dimensional outline	442.2(H) × 286.6(V) × 10.2(D) typ.	mm
Weight	TBD	gram
Active area	521.28 (H) × 293.22 (V)	mm
Pixel pitch	0.2715 (H) × 0.2715(V)	mm
Number of pixels	1920 (H) × 1080 (V) (1 pixel = R + G + B dots)	pixels

### 10.2 Mounting

See FIGURE 5 . (shown in Appendix)

### 10.3 Anti-Glare and Polarizer Hardness.

The surface of the LCD has an anti-glare coating to minimize reflection and a coating to reduce scratching.

### 10.4 Light Leakage

There shall not be visible light from the back-lighting system around the edges of the screen as seen from a distance 50cm from the screen with an overhead light level of 350lux.

SPEC. NUMBER S	SPEC. TITLE MV236FHB-N10 Product Specification Rev. 0	P 19
-------------------	--	---------

### 11.0 RELIABILITY TEST

The Reliability test items and its conditions are shown in below.

<Table 7 Reliability Test Parameters >

No	Test Items	Conditions
1	High temperature storage test	Ta = 60 °C, 240 hrs
2	Low temperature storage test	Ta = -20 °C, 240 hrs
3	High temperature & high humidity operation test	Ta = 50 °C, 80%RH, 240hrs
4	High temperature operation test	Ta = 50 °C, 240hrs
5	Low temperature operation test	Ta = -5°C, 240hrs
6	Thermal shock	Ta = -20 °C ↔ 60 °C (0.5 hr), 100 cycle
7	Vibration test (non-operating)	Frequency Random, 1 ~ 200 Hz, Gravity 1.05 Grms Period +Z 60 min
8	Electro-static discharge test	Air : 150 pF, 330Ω, 15 KV Contact : 150 pF, 330Ω, 8 KV PCBA Pin Contact: 3times/Point, ± 5KV

<b>BOE</b>	<b>PRODUCT GROUP</b>	REV	ISSUE DATE
	Customer SPEC	Rev. 0	Jun.05.2015

## 12.0 HANDLING & CAUTIONS

- (1) Cautions when taking out the module
  - Pick the pouch only, when taking out module from a shipping package.
- (2) Cautions for handling the module
  - As the electrostatic discharges may break the LCD module, handle the LCD module with care. Peel a protection sheet off from the LCD panel surface as slowly as possible.
  - As the LCD panel and back - light element are made from fragile glass material, impulse and pressure to the LCD module should be avoided.
  - As the surface of the polarizer is very soft and easily scratched, use a soft dry cloth without chemicals for cleaning.
  - Do not pull the interface connector in or out while the LCD module is operating.
  - Put the module display side down on a flat horizontal plane.
  - Handle connectors and cables with care.
- (3) Cautions for the operation
  - When the module is operating, do not lose CLK, ENAB signals. If any one of these signals is lost, the LCD panel would be damaged.
  - Obey the supply voltage sequence. If wrong sequence is applied, the module would be damaged.
- (4) Cautions for the atmosphere
  - Dew drop atmosphere should be avoided.
  - Do not store and/or operate the LCD module in a high temperature and/or humidity atmosphere. Storage in an electro-conductive polymer packing pouch and under relatively low temperature atmosphere is recommended.
- (5) Cautions for the module characteristics
  - Do not apply fixed pattern data signal to the LCD module at product aging.
  - Applying fixed pattern for a long time may cause image sticking.
- (6) Other cautions
  - Do not disassemble and/or re-assemble LCD module.
  - Do not re-adjust variable resistor or switch etc.
  - When returning the module for repair or etc., Please pack the module not to be broken. We recommend to use the original shipping packages.

SPEC. NUMBER S	SPEC. TITLE MV236FHB-N10 Product Specification Rev. 0	P 21
-------------------	--	---------

<b>BOE</b>	<b>PRODUCT GROUP</b>	REV	ISSUE DATE
	Customer SPEC	Rev. 0	Jun.05.2015

### 13.0 PRODUCT SERIAL NUMBER

DP/N XXXXXX	MV236FHB-N10	B4	<b>BOE</b>
XXXX	XXXXXXXXXXXXXXXXXXXXXX	REV A00	<b>ECO</b> RoHS Compliant <b>UL</b> C US
XX-XXXXXX-XXXXX-XXX-XXXX			MADE IN CHINA

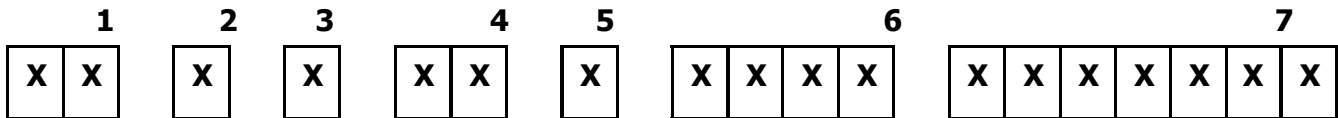

- |                                     |                                    |
|-------------------------------------|------------------------------------|
| 1. Control Number                   | 5. Month (1,2,3, ... , 9, X, Y, Z) |
| 2. Rank / Grade                     | 6. Internal Use                    |
| 3. Line Classification              | 7. Serial Number                   |
| 4. Year (2001 : 01, 2002 : 02, ...) |                                    |

SPEC. NUMBER S	SPEC. TITLE MV236FHB-N10 Product Specification Rev. 0	P 22
-------------------	--	---------

### 14.0 Packing

#### 14.1 Packing Order

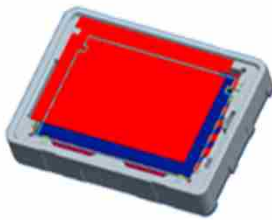

Put EPE pads and open cells into the box, 20pcs open cells per box.

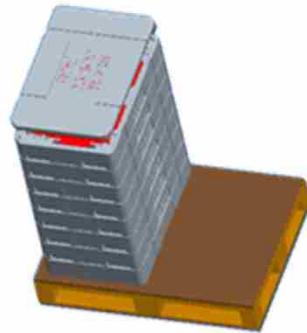

Place the paper pad on the pallet, and put the EPO boxes on the pallet (8ea boxes per row) and a cover on the top of the boxes.

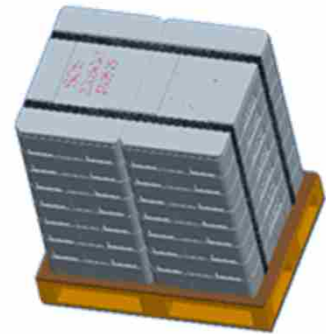

Pack with 2 belts (16ea boxes and 2 covers per pallet).

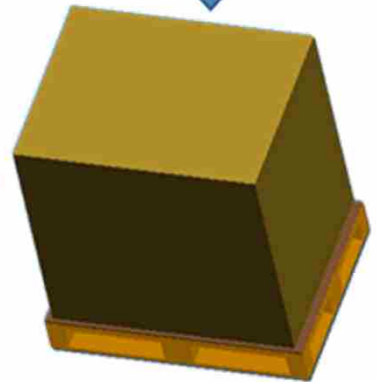

Cover with 1 out box.

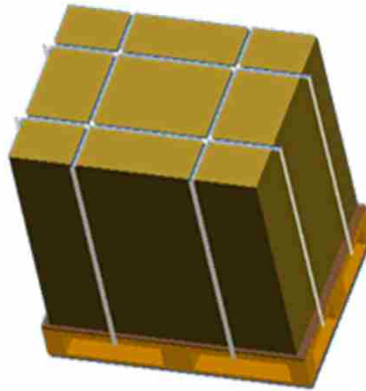

Pack with 4 packing belts.

20pcs OC/box

16boxes/Pallet

320pcs OC/Pallet

<b>BOE</b>	<b>PRODUCT GROUP</b>	REV	ISSUE DATE
	Customer SPEC	Rev. 0	Jun.05.2015

**14.2 Packing Note**

- Box Dimension : 480mm(W) 690mm(L) 110mm(H)
- Package Quantity in one Box : 20pcs

**14.3 Box label**

- Label Size : 108 mm (L) 56 mm (W)
- Contents  
 Model : MV236FHB-N10  
 Q`ty : Module 20 Q`ty in one box  
 Serial No. : Box Serial No. See next page for detail description.  
 Date : Packing Date



**MODEL :** MV236FHB-N10      **Q'TY :** 20

**SERIAL NO. :** 00000000000000      **DATE :**



• QAA0330000268 •

XXXX



(QA)

00	0	00	0	0	000000
Type	Grade	Year	Month	ITEM-CODE	Serial_no

Internal Use

RoHS Mark

SPEC. NUMBER S	SPEC. TITLE MV236FHB-N10 Product Specification Rev. 0	P 24
-------------------	--	---------

## 15.0 APPENDIX

**Figure 1. Measurement Set Up**

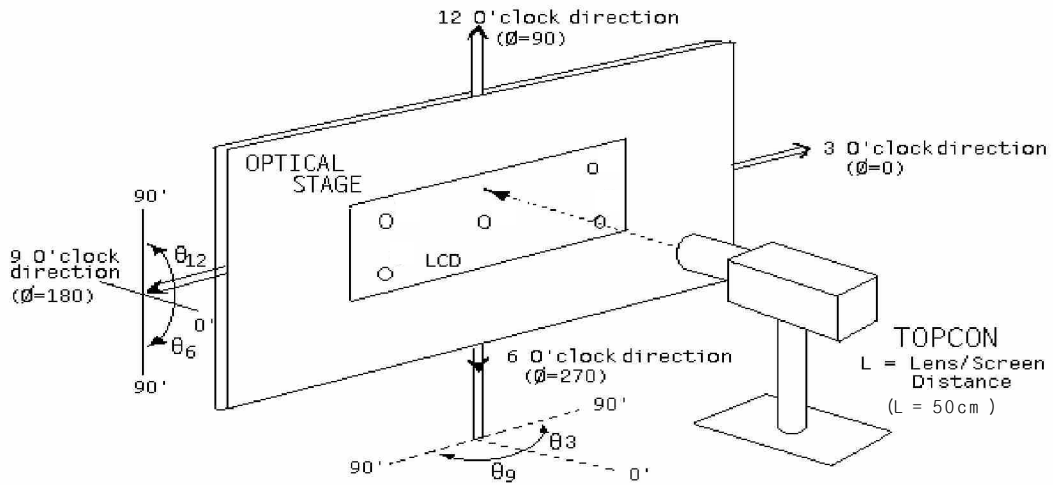

**Figure 2. White Luminance and Uniformity Measurement Locations (9 points)**

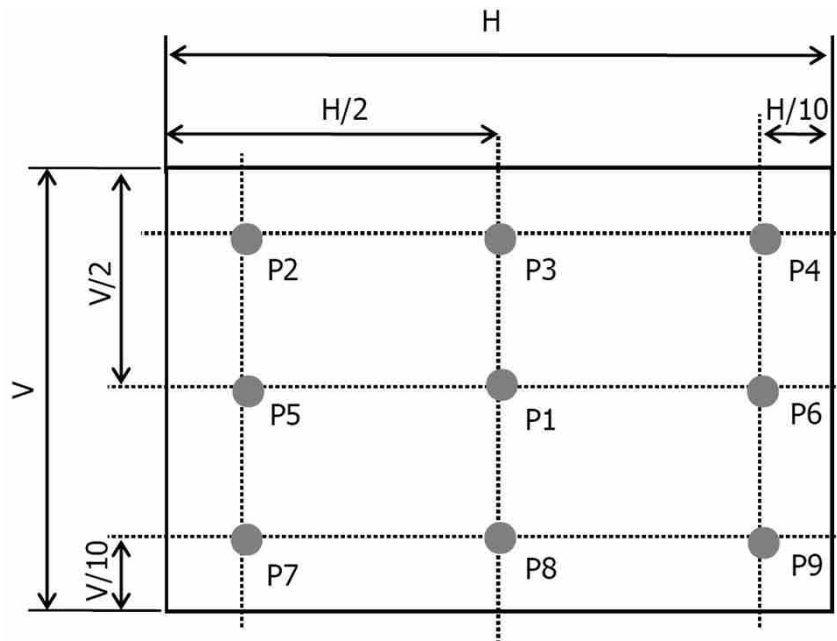

SPEC. NUMBER S	SPEC. TITLE MV236FHB-N10 Product Specification Rev. 0	P 25
-------------------	--	---------

**Figure 3. Response Time Testing**



**Figure 4. Cross Modulation Test Description**

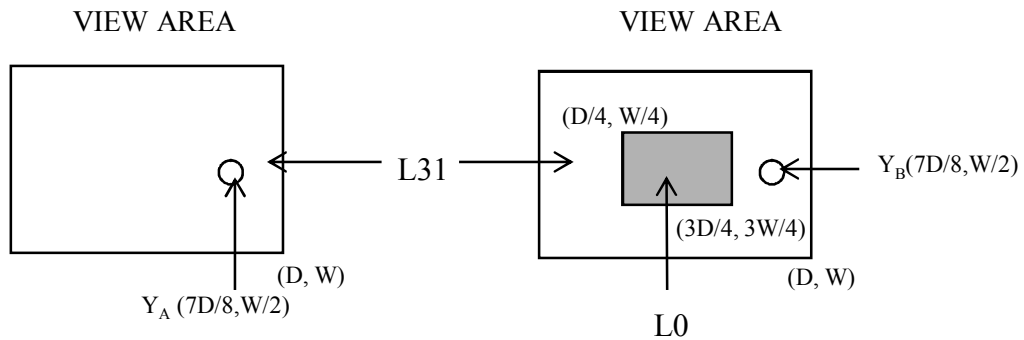

$$\text{Cross-Talk (\%)} = \left| \frac{Y_B - Y_A}{Y_A} \right| \times 100$$

Where:  $Y_A$  = Initial luminance of measured area (cd/m<sup>2</sup>)  
 $Y_B$  = Subsequent luminance of measured area (cd/m<sup>2</sup>)  
 The location measured will be exactly the same in both patterns

**Figure 5. TFT-LCD Open Cell Outline Dimensions (Front view)**

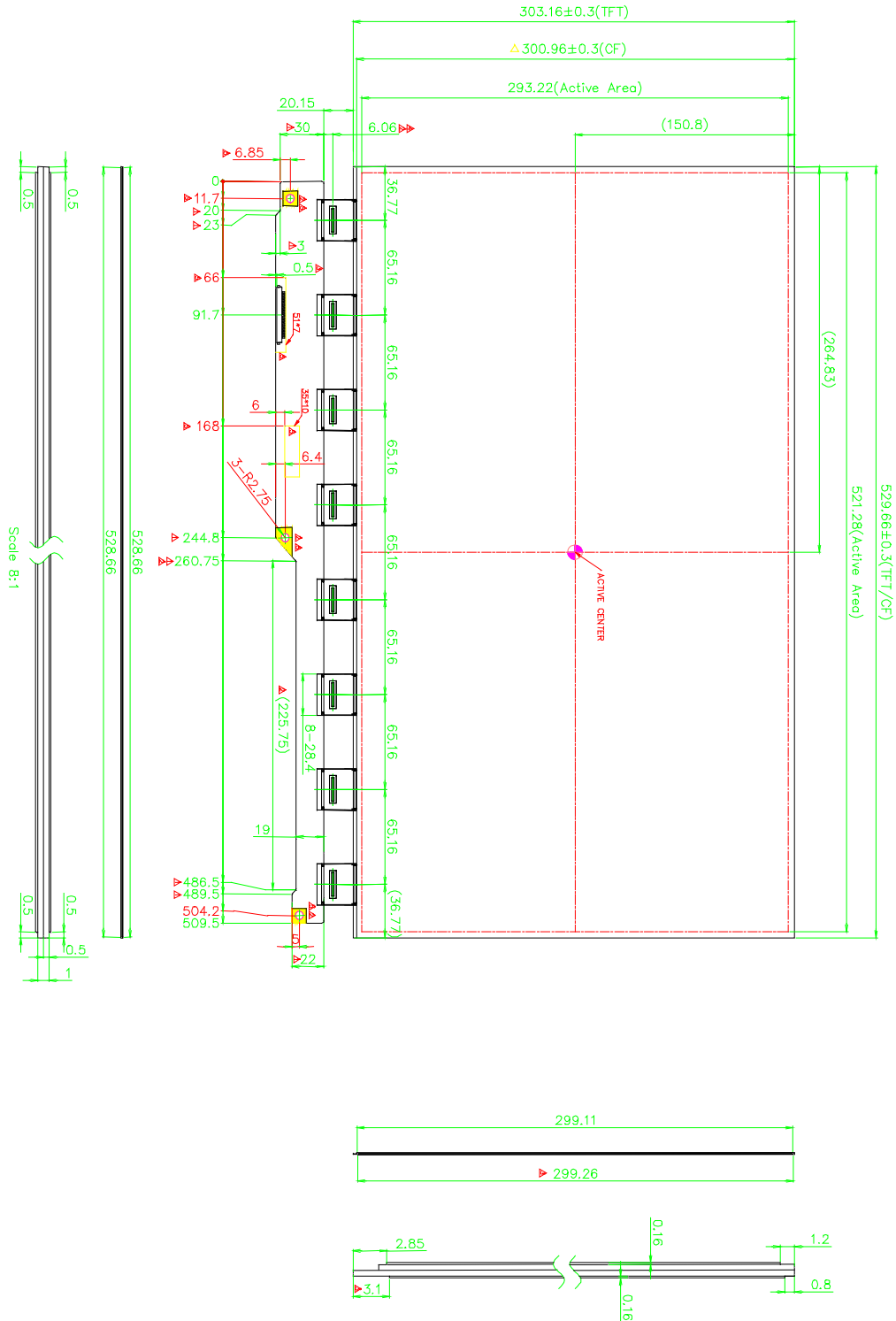

<p>SPEC. NUMBER S</p>	<p>SPEC. TITLE MV236FHB-N10 Product Specification Rev. 0</p>	<p>P 27</p>
---------------------------	--	-----------------