



SPECIFICATION

BOE

DV210FBM-N00

20,9" TFT - FHD - LVDS

Version: 1.0

Date: 01.07.2017

Note: This specification is subject to change without prior notice



PROPRIETARY NOTE

THIS SPECIFICATION IS THE PROPERTY OF BOEFZ AND SHALL NOT BE REPRODUCED OR COPIED WITHOUT THE WRITTEN PERMISSION OF BOEFZ AND MUST BE RETURNED TO BOEFZ UPON ITS REQUEST

SPEC. NUMBER
NO. S8-65-8D-001

PRODUCT GROUP
TFT-LCD

Rev. P0

ISSUE DATE
2017.07.01

PAGE
1 OF 27

TITLE :

DV210FBM-N00 Product Specification

Fuzhou BOE Optoelectronics Technology Co.,Ltd

| | | | |
|------------|----------------------|------------|-------------------|
| BOE | PRODUCT GROUP | REV | ISSUE DATE |
| | TFT- LCD PRODUCT | P0 | 2017.07.01 |

| | | |
|---|--|------------------------|
| SPEC. NUMBER NO. S8-65-8D-001 | SPEC. TITLE DV210FBM-N00 Product Specification | PAGE 2 OF 27 |
|---|--|------------------------|

REVISION HISTORY

| REV. | ECN No. | DESCRIPTION OF CHANGES | DATE | PREPARED |
|------|---------|------------------------|------------|----------|
| P0 | - | Initial Release | 2017.07.01 | W.C WANG |
| | | | | |
| | | | | |
| | | | | |
| | | | | |
| | | | | |
| | | | | |
| | | | | |
| | | | | |
| | | | | |
| | | | | |
| | | | | |

| | | | |
|---|---|-----|-----------------|
| BOE | PRODUCT GROUP | REV | ISSUE DATE |
| | TFT- LCD PRODUCT | P0 | 2017.07.01 |
| SPEC. NUMBER NO. S8-65-8D-001 | SPEC. TITLE DV210FBM-N00 Product Specification | | PAGE 3 OF 27 |

Contents

| No | ITEM | Page |
|----|--|------|
| | REVISIONS HISTORY | 2 |
| | CONTENTS | 3 |
| 1 | GENERAL DESCRIPTION | 4 |
| | 1.1 Introduction | |
| | 1.2 Features | |
| | 1.3 Applications | |
| | 1.4 General Specification | |
| 2 | ABSOLUTE MAXIMUM RATINGS | 6 |
| 3 | ELECTRICAL SPECIFICATIONS | 7 |
| | 3.1 TFT LCD Open Cell | |
| 4 | INTERFACE CONNECTION | 8 |
| | 4.1 Open Cell Input Signal & Power | |
| | 4.2 LVDS Interface | |
| | 4.3 LVDS Rx Interface Timing Parameter | |
| | 4.4 LVDS Rx Interface Eye Diagram | |
| | 4.5 LVDS Receiver Differential Input | |
| 5 | SIGNAL TIMING SPECIFICATIONS | 14 |
| | 5.1 Timing Parameters (DE only mode) | |
| | 5.2 Signal Timing Waveform | |
| | 5.3 Input Signals, Basic Display Colors and Gray Scale of Colors | |
| | 5.4 Power Sequence | |
| 6 | OPTICAL SPECIFICATIONS | 18 |
| 7 | MECHANICAL CHARACTERISTICS | 20 |
| 8 | RELIABILITY TEST | 21 |
| 9 | PRODCUT SERIAL NUMBER | 22 |
| 10 | PACKING INFORMATION | 23 |
| 11 | HANDING & CAUTIONS | 25 |
| 12 | APPENDIX | 26 |

| | | | |
|---|---|-----|-----------------|
| BOE | PRODUCT GROUP | REV | ISSUE DATE |
| | TFT- LCD PRODUCT | P0 | 2017.07.01 |
| SPEC. NUMBER NO. S8-65-8D-001 | SPEC. TITLE DV210FBM-N00 Product Specification | | PAGE 4 OF 27 |

1.0 GENERAL DESCRIPTION

1.1 Introduction

DV210FBM-N00 is a color active matrix TFT LCD MDL using amorphous silicon TFT's (Thin Film Transistors) as an active switching devices. This MDL has a 20.9 inch diagonally measured active area with FHD resolutions (1920 horizontal by 132 vertical pixel array). Each pixel is divided into RED, GREEN, BLUE dots which are arranged in vertical stripe and this module can display 16.7M colors. The TFT-LCD MDL panel is adapted for a low reflection and higher color type.

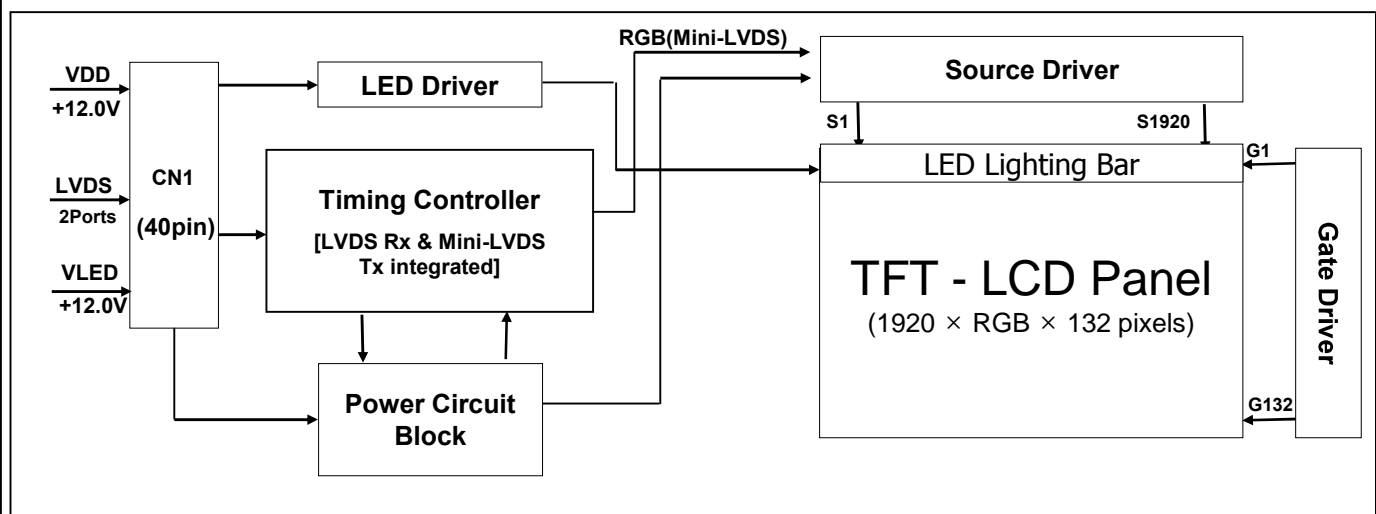

1.2 Features

- LVDS interface with 2 pixel / clock
- High-speed response
- Low color shift image quality
- 8-bit color depth, display 16.7M colors
- Wide viewing angle
- DE (Data Enable) only mode
- HADS technology is applied for high display quality
- RoHS compliant

| | | | |
|---|---|-----|-----------------|
| BOE | PRODUCT GROUP | REV | ISSUE DATE |
| | TFT- LCD PRODUCT | P0 | 2017.07.01 |
| SPEC. NUMBER NO. S8-65-8D-001 | SPEC. TITLE DV210FBM-N00 Product Specification | | PAGE 5 OF 27 |

1.3 Application

- Home Alone Multimedia TFT-LCD TV
- Display Terminals for Control System
- Full High Definition TV(FHD TV)
- AV application Products

1.4 General Specification

< Table 1. General Specifications >

| Parameter | Specification | Unit | Remarks |
|-------------------------|--------------------------------|--------|------------------------------|
| Active area | 529.416(H) × 36.39735(V) | mm | |
| Number of pixels | 1920(H) × 132(V) | pixels | |
| Pixel pitch | 91.9125(H) × 275.7375(V) | mm | |
| Pixel arrangement | Pixels RGB Vertical stripe | | |
| Display colors | 16.7M | colors | 8bits True |
| Display mode | Normally Black | | |
| Open Cell Transmittance | 5.15 (Typ.) | % | At center point with BOE BLU |
| Dimensional outline | 542.4(H) × 54.7(V) × 8.0(B) . | mm | Detail refer to drawing |
| Weight | TBD (typ.) | g | |
| Power Consumption | 7 | Watt | Typ. |
| Bezel width (L/R/U/D) | 6/6/11.3/6 | mm | |
| Surface Treatment | Haze 25% | | |
| Back-light | Up edge side, 1- LED Light bar | | |

2.0 ABSOLUTE MAXIMUM RATINGS

The followings are maximum values which, if exceed, may cause faulty operation or damage to the unit. The operational and non-operational maximum voltage and current values are listed in Table 2.

< Table 2. Open Cell Electrical Specifications >

[VSS=GND=0V]

| Parameter | Symbol | Min. | Max. | Unit | Remark |
|----------------------------|------------------|---------|------|------|------------|
| Power Supply Voltage | VDD | VSS-0.3 | 13.5 | V | Ta = 25 °C |
| Operating Temperature | T _{OP} | 0 | +50 | °C | Note 1 |
| Storage Temperature | T _{SUR} | -20 | +60 | °C | |
| | T _{ST} | -20 | +60 | °C | |
| Operating Ambient Humidity | Hop | 10 | 80 | %RH | |
| Storage Humidity | Hst | 10 | 80 | %RH | |

Note 1 : Temperature and relative humidity range are shown in the figure below.
Wet bulb temperature should be 39 °C max. and no condensation of water.

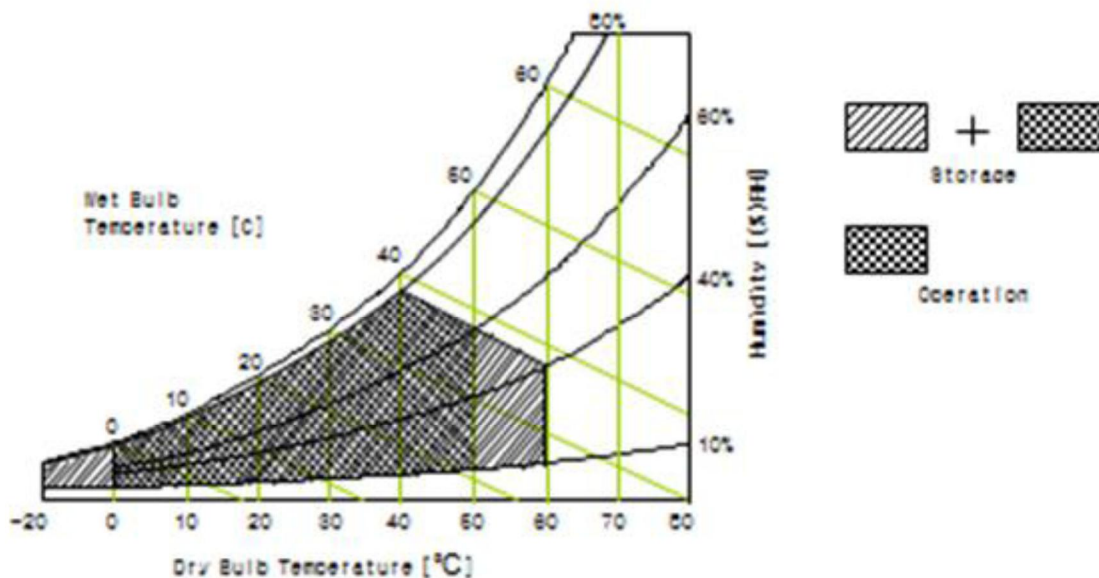

| | | | |
|---|---|-----------------|------------|
| BOE | PRODUCT GROUP | REV | ISSUE DATE |
| | TFT- LCD PRODUCT | P0 | 2017.07.01 |
| SPEC. NUMBER NO. S8-65-8D-001 | SPEC. TITLE DV210FBM-N00 Product Specification | PAGE 7 OF 27 | |

3.0 ELECTRICAL SPECIFICATIONS

3.1 TFT LCD Open Cell

< Table 3. Open Cell Electrical Specifications >

[Ta =25±2 °C]

| Parameter | Symbol | Values | | | Unit | Remark | |
|-----------------------------|---|--------|------|------|------|--------|--|
| | | Min | Typ | Max | | | |
| Power Supply Input Voltage | VDD | 10.8 | 12 | 13.2 | Vdc | | |
| Power Supply Ripple Voltage | VRP | | | 300 | mV | | |
| Power Supply Current | IDD | - | 250 | 500 | mA | Note 1 | |
| Power Consumption | PDD | - | 3 | 6 | Watt | | |
| Rush current | IRUSH | - | - | 3.0 | A | Note 2 | |
| LVDS Interface | Differential Input High Threshold Voltage | VLVTH | +100 | | +300 | mV | |
| | Differential Input Low Threshold Voltage | VLVTL | -300 | | -100 | mV | |
| | Common Input Voltage | VLVC | 1.0 | 1.2 | 1.4 | V | |
| CMOS Interface | Input High Threshold Voltage | VIH | 2.7 | - | 3.3 | V | |
| | Input Low Threshold Voltage | VIL | 0 | - | 0.6 | V | |

Note 1 : The supply voltage is measured and specified at the interface connector of LCM.

The current draw and power consumption specified is for VDD=12.0V,

Frame rate $f_v=60\text{Hz}$ and Clock frequency = 74.25MHz.

Test Pattern of power supply current

a) Typ : Mosaic 7X5 (L0/L255)

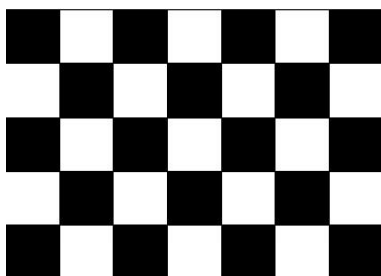

b) Max : Horizontal 1 Line (L0/L255)

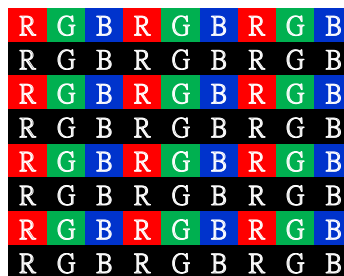

c) Flicker Pattern

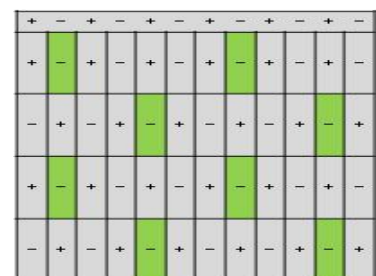

Note 2 : The duration of rush current is about 2ms and rising time of Power Input is 1ms(min)

3.0 ELECTRICAL SPECIFICATIONS

3.2 Backlight Unit

< Table 3. Backlight Unit Electrical Specifications >

[Ta =25±2 °C]

| Parameter | | Min. | Typ. | Max. | Unit | Remarks |
|-------------------------------------|------------------|-------|------|--------|------|-----------|
| LED Forward Voltage | V _F | - | - | 3.2 | V | - |
| LED Forward Current | I _F | - | 14 | | mA | - |
| LED Power Consumption | P _{LED} | | 4 | - | W | Note 1 |
| LED Life-Time | N/A | 30000 | - | - | Hour | IF = 14mA |
| Power supply voltage for LED Driver | VLED | 5 | 12 | 21 | V | |
| EN Control Level | Backlight on | 2.1 | 3.3 | 5.0 | V | |
| | Backlight off | 0 | - | 0.8 | V | |
| PWM Control Level | PWM High Level | 2.1 | 3.3 | 5.0 | V | |
| | PWM Low Level | 0 | - | 0.6 | V | |
| PWM Control Frequency | F _{PWM} | 100 | - | 10,000 | Hz | |
| Duty Ratio | - | 1 | - | 100 | % | |

Notes : 1. Power supply voltage 12V for LED Driver, Driver efficiency 87%,
 Calculator Value for reference $I_F \times V_F \times 77 / 0.87 = P_{LED}$

2. The LED Life-time define as the estimated time to 50% degradation of initial luminous.

| | | | |
|---|---|-----------------|------------|
| BOE | PRODUCT GROUP | REV | ISSUE DATE |
| | TFT- LCD PRODUCT | P0 | 2017.07.01 |
| SPEC. NUMBER NO. S8-65-8D-001 | SPEC. TITLE DV210FBM-N00 Product Specification | PAGE 9 OF 27 | |

4.0 INTERFACE CONNECTION

4.1 Open Cell Input Signal & Power

- LVDS Connector : MSAK24025P40 (STM) or IS050-L40B-C10(UJU).

< Table 4. Open Cell Input Connector Pin Configuration >

| Pin No | Symbol | Description | Pin No | Symbol | Description |
|--------|--------|--|--------|--------|--|
| 1 | RX00- | Negative Transmission data of Pixel 0 (ODD) | 16 | RXE1+ | Positive Transmission data of Pixel 1 (EVEN) |
| 2 | RX00+ | Positive Transmission data of Pixel 0 (ODD) | 17 | GND | Power Ground |
| 3 | RX01- | Negative Transmission data of Pixel 1 (ODD) | 18 | RXE2- | Negative Transmission data of Pixel 2 (EVEN) |
| 4 | RX01+ | Positive Transmission data of Pixel 1 (ODD) | 19 | RXE2+ | Positive Transmission data of Pixel 2 (EVEN) |
| 5 | RX02- | Negative Transmission data of Pixel 2 (ODD) | 20 | RXEC- | Negative Transmission Clock (EVEN) |
| 6 | RX02+ | Positive Transmission data of Pixel 2 (ODD) | 21 | RXEC+ | Positive Transmission Clock (EVEN) |
| 7 | GND | Power Ground | 22 | RXE3- | Negative Transmission data of Pixel 3 (EVEN) |
| 8 | RXOC- | Negative Transmission Clock (ODD) | 23 | RXE3+ | Positive Transmission data of Pixel 3 (EVEN) |
| 9 | RXOC+ | Positive Transmission Clock (ODD) | 24 | GND | Power Ground |
| 10 | RX03- | Negative Transmission data of Pixel 3 (ODD) | 25 | CTL | CTL_DVR for LCD manufacturer |
| 11 | RX03+ | Positive Transmission data of Pixel 3 (ODD) | 26 | CE | CE_DVR for LCD manufacturer |
| 12 | RXE0- | Negative Transmission data of Pixel 0 (EVEN) | 27 | NC | Not connection |
| 13 | RXE0+ | Positive Transmission data of Pixel 0 (EVEN) | 28 | VDD | Power Supply : +12V |
| 14 | GND | Power Ground | 29 | VDD | |
| 15 | RXE1- | Negative Transmission data of Pixel 1 (EVEN) | 30 | VDD | |

| | | | |
|---|---|-----|------------------|
| BOE | PRODUCT GROUP | REV | ISSUE DATE |
| | TFT- LCD PRODUCT | P0 | 2017.07.01 |
| SPEC. NUMBER NO. S8-65-8D-001 | SPEC. TITLE DV210FBM-N00 Product Specification | | PAGE 10 OF 27 |

| Pin No | Symbol | Description | Pin No | Symbol | Description |
|--------|--------|-------------------|--------|--------|-------------------------|
| 31 | NC | Not connection | 36 | GND | Power Ground |
| 32 | GND | Power Ground | 37 | VLED | LED Power Supply : +12V |
| 33 | LED_EN | LED Enable : 3.3V | 38 | VLED | |
| 34 | PWM | Dimming : 3.3V | 39 | VLED | |
| 35 | GND | Power Ground | 40 | VLED | |

- Notes : 1. NC(Not Connected) : This pins are only used for BOE internal operations.
2. Input Level of LVDS signal is based on the EIA-644 Standard.

Front view of LCM

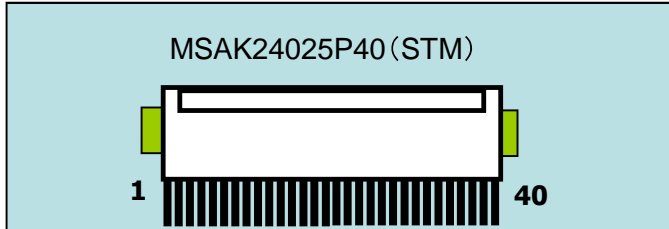

BIST Pattern



4.2 LVDS Interface

- LVDS Receiver : Timing Controller (LVDS Rx merged) / LVDS Data : Pixel Data

< Table 5. Open Cell Input Connector Pin Configuration >

| Channel No. | Data No. | 8-bit LVDS Type | |
|-------------|----------|-----------------|-------|
| | | NS | JEIDA |
| 0 | Bit-0 | R0 | R2 |
| | Bit-1 | R1 | R3 |
| | Bit-2 | R2 | R4 |
| | Bit-3 | R3 | R5 |
| | Bit-4 | R4 | R6 |
| | Bit-5 | R5 | R7 |
| | Bit-6 | G0 | G2 |
| 1 | Bit-0 | G1 | G3 |
| | Bit-1 | G2 | G4 |
| | Bit-2 | G3 | G5 |
| | Bit-3 | G4 | G6 |
| | Bit-4 | G5 | G7 |
| | Bit-5 | B0 | B2 |
| | Bit-6 | B1 | B3 |
| 2 | Bit-0 | B2 | B4 |
| | Bit-1 | B3 | B5 |
| | Bit-2 | B4 | B6 |
| | Bit-3 | B5 | B7 |
| | Bit-4 | HS | HS |
| | Bit-5 | VS | VS |
| | Bit-6 | DE | DE |
| 3 | Bit-0 | R6 | R0 |
| | Bit-1 | R7 | R1 |
| | Bit-2 | G6 | G0 |
| | Bit-3 | G7 | G1 |
| | Bit-4 | B6 | B0 |
| | Bit-5 | B7 | B1 |
| | Bit-6 | - | |

4.3 LVDS Rx Interface Timing Parameter

The specification of the LVDS Rx interface timing parameter is shown in Table 6.

<Table 6. LVDS Rx Interface Timing Specification>

| Item | Symbol | Min | Typ | Max | Unit | Remark |
|--------------|--------|------------------|--------------|------------------|------|--------|
| CLKIN Period | tRCIP | 10.31 | 13.47(10.78) | 15.87 | nsec | |
| Input Data 0 | tRIP1 | -0.42 | 0.0 | +0.42 | nsec | |
| Input Data 1 | tRIP0 | tRCIP/7-0.42 | tRCIP/7 | tRCIP/7+0.42 | nsec | |
| Input Data 2 | tRIP6 | 2 × tRCIP/7-0.42 | 2 × tRCIP/7 | 2 × tRCIP/7+0.42 | nsec | |
| Input Data 3 | tRIP5 | 3 × tRCIP/7-0.42 | 3 × tRCIP/7 | 3 × tRCIP/7+0.42 | nsec | |
| Input Data 4 | tRIP4 | 4 × tRCIP/7-0.42 | 4 × tRCIP/7 | 4 × tRCIP/7+0.42 | nsec | |
| Input Data 5 | tRIP3 | 5 × tRCIP/7-0.42 | 5 × tRCIP/7 | 5 × tRCIP/7+0.42 | nsec | |
| Input Data 6 | tRIP2 | 6 × tRCIP/7-0.42 | 6 × tRCIP/7 | 6 × tRCIP/7+0.42 | nsec | |

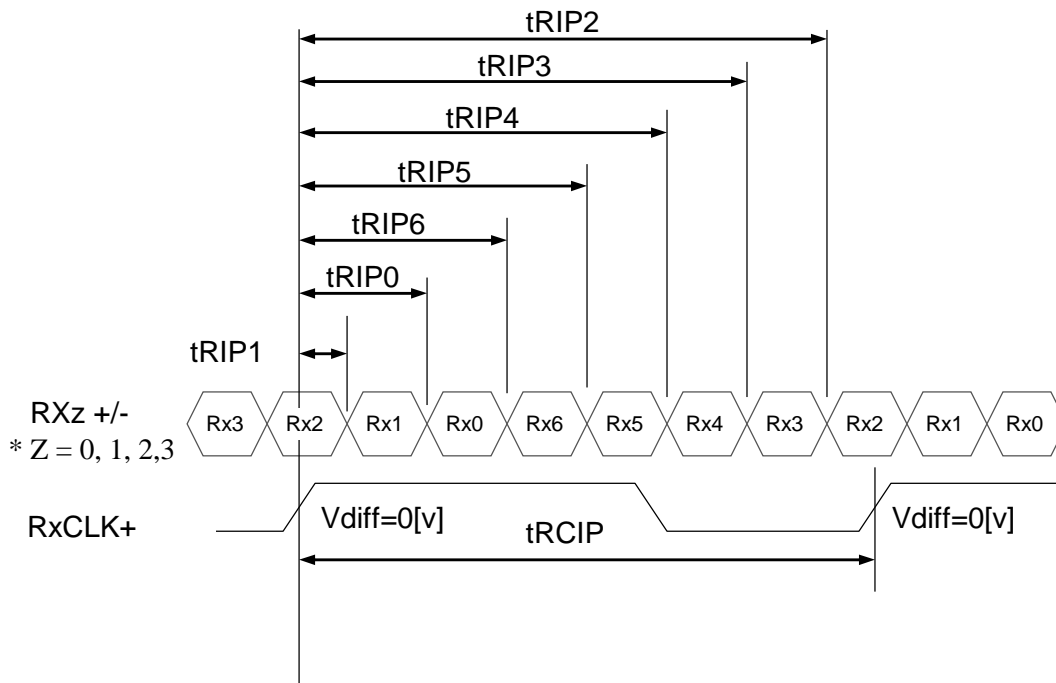

* Vdiff = (RXz+)-(RXz-),.... ,(RXCLK+)-(RXCLK-)

| | | | |
|---|---|-----|------------------|
| BOE | PRODUCT GROUP | REV | ISSUE DATE |
| | TFT- LCD PRODUCT | P0 | 2017.07.01 |
| SPEC. NUMBER NO. S8-65-8D-001 | SPEC. TITLE DV210FBM-N00 Product Specification | | PAGE 13 OF 27 |

4.4 LVDS Rx Interface Eye Diagram

< Table 7. LVDS Rx Interface Eye Diagram >

| Symbol | Min | Typ | Max | Unit | Note |
|--------|-----|------|-----|------|------|
| A | — | 100 | — | mV | |
| B | — | 100 | — | mV | |
| C | — | 0 | — | mV | |
| D | — | -100 | — | mV | |
| E | — | -100 | — | mV | |
| F | — | 0 | — | mV | |

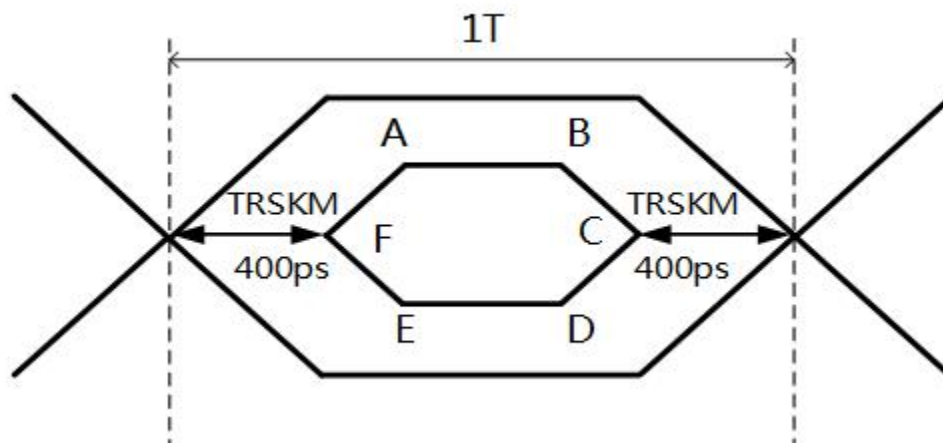

- Notes: 1. Time F to A,B to C,C to D,E to F is 150p second.
 2. LVDS clock=85Mhz.
 3. The time A to B=1T-2*TRSKM-2*150ps.

4.5 LVDS Receiver Differential Input

< Table 7-1. LVDS Receiver Differential Input >

| Symbol | Parameter | Min | Typ | Max | Unit | Condition |
|------------|---|--------------|-----|--------------------|------|-------------------|
| R_{xVTH} | Differential input high threshold voltage | | | +0.1V | V | $R_{xVCM} = 1.2V$ |
| R_{xVTL} | Differential input low threshold voltage | -0.1V | | | V | |
| R_{xVIN} | Input voltage range (singled-end) | 0 | | 2.4 | V | |
| R_{xVCM} | Differential input common mode voltage | $ V_{ID} /2$ | | $2.4 - V_{ID} /2$ | V | |
| $ V_{ID} $ | Differential input voltage | 0.1 | | 0.6 | V | |

Single-end Signals

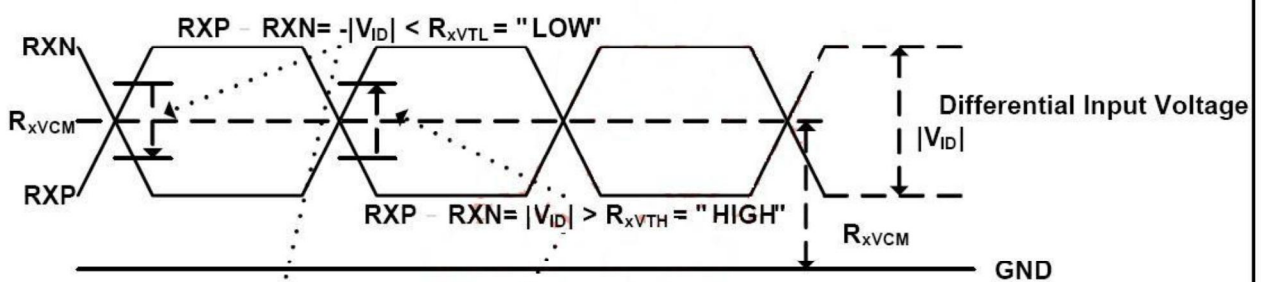

Differential Signal

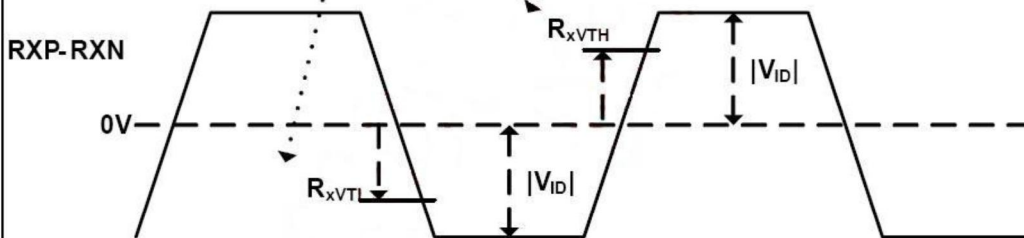

| | | | |
|---|---|-----|------------------|
| BOE | PRODUCT GROUP | REV | ISSUE DATE |
| | TFT- LCD PRODUCT | P0 | 2017.07.01 |
| SPEC. NUMBER NO. S8-65-8D-001 | SPEC. TITLE DV210FBM-N00 Product Specification | | PAGE 15 OF 27 |

5.0 SIGNAL TIMING SPECIFICATION

5.1 Timing Parameters (DE only mode)

< Table 8. Timing Table >

| Item | | Symbols | Min | Typ | Max | Unit | |
|--------------------------------|-----------|---------|-----------------|-------|------|-------|------------------|
| Clock | Frequency | 1/Tc | 60 | 74.25 | 78 | MHz | |
| | High Time | Tch | - | 4/7Tc | - | | |
| | Low Time | Tcl | - | 4/7Tc | - | | |
| Frame Period | | Tv | 1100 | 1125 | 1149 | lines | |
| | | | 48.5 | 60 | 63 | Hz | |
| Horizontal Active Display Term | | Valid | t _{HV} | - | 960 | - | t _{CLK} |
| | | Total | t _{HP} | 1060 | 1100 | 1200 | t _{CLK} |
| Vertical Active Display Term | | Valid | t _{VV} | - | 1080 | - | t _{HP} |
| | | Total | t _{VP} | 1100 | 1125 | 1149 | t _{HP} |

Notes: This product is DE only mode. The input of Hsync & Vsync signal does not have an effect on normal operation.

< Table 9. LVDS Input SSCG >

| Symbol | Parameter | Condition | Min | Typ | Max | Unit |
|--------------------|---|--|------|-------|------|------|
| F | LVDS Input frequency | - | 60 | 74.25 | 78 | MHz |
| T _{LVSK} | LVDS channel to channel skew | F=100MHz V _{IC} =1.2V V _{ID} =±400mV | -380 | - | +380 | ps |
| F _{LVMOD} | Modulating frequency of input clock during SSC | | 60 | - | 85 | KHz |
| F _{LVDEV} | Maximum deviation of input clock frequency during SSC | | -3 | - | +3 | % |
| T _{CY-CY} | Cycle to Cycle jitter | | - | - | 100 | ps |

5.2 Signal Timing Waveform

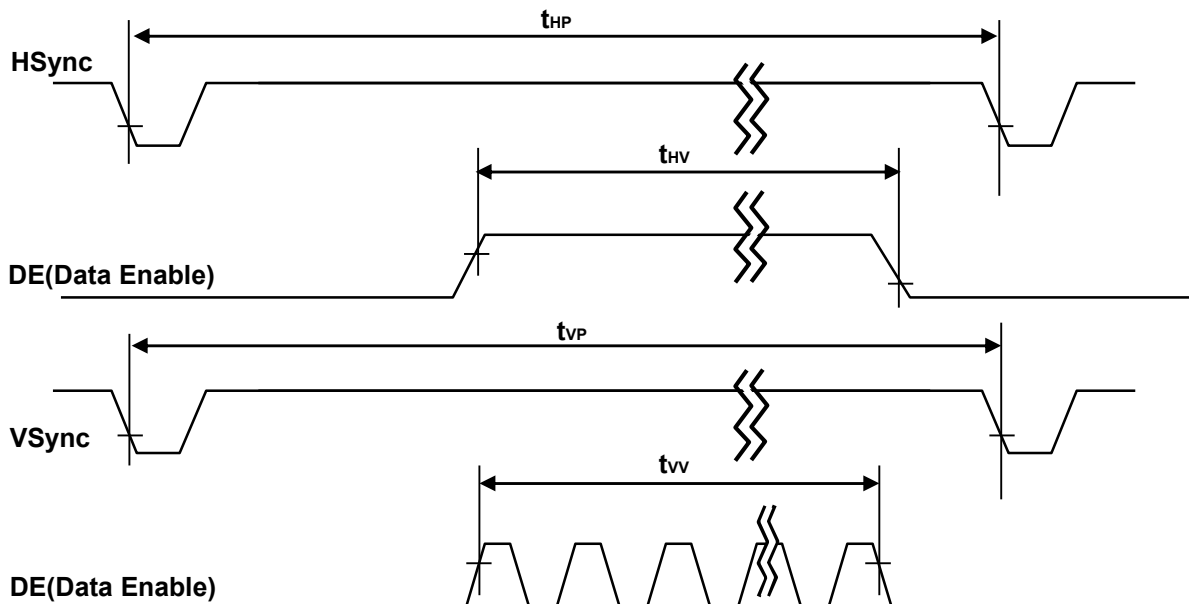
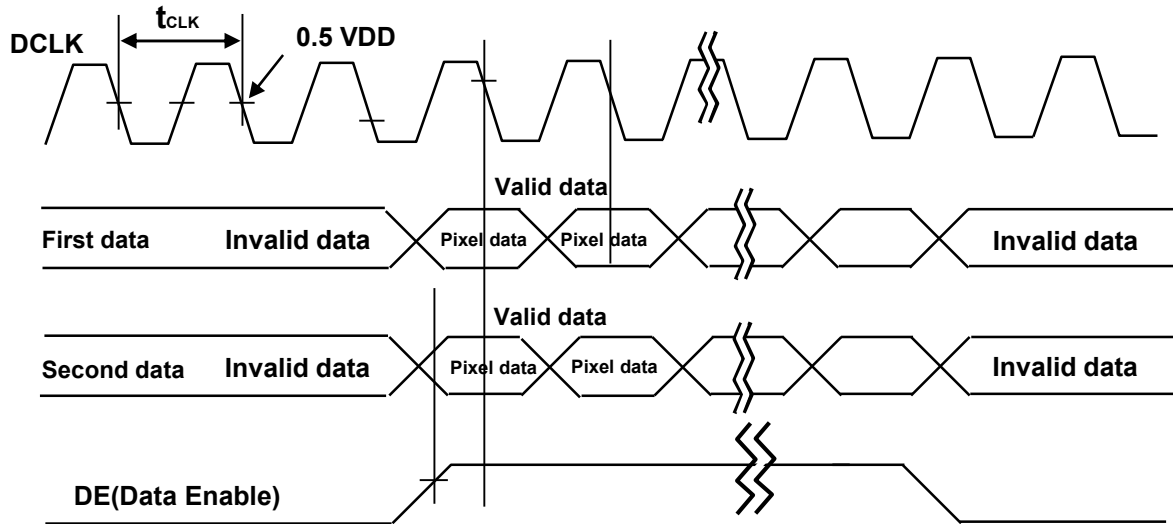

5.3 Input Signals, Basic Display Colors and Gray Scale of Colors

< Table 10. Input Signal and Display Color Table >

| Color & Gray Scale | | Input Data Signal | | | | | | | | | | | | | | | | | | | | | | | |
|---------------------|----------|-------------------|----|----|----|----|----|----|----|------------|----|----|----|----|----|-----------|----|----|----|----|----|----|----|----|----|
| | | Red Data | | | | | | | | Green Data | | | | | | Blue Data | | | | | | | | | |
| | | R7 | R6 | R5 | R4 | R3 | R2 | R1 | R0 | G7 | G6 | G5 | G4 | G3 | G2 | G1 | G0 | B7 | B6 | B5 | B4 | B3 | B2 | B1 | B0 |
| Basic Colors | Black | 0 | 0 | 0 | 0 | 0 | 0 | 0 | 0 | 0 | 0 | 0 | 0 | 0 | 0 | 0 | 0 | 0 | 0 | 0 | 0 | 0 | 0 | 0 | 0 |
| | Blue | 0 | 0 | 0 | 0 | 0 | 0 | 0 | 0 | 0 | 0 | 0 | 0 | 0 | 0 | 0 | 0 | 1 | 1 | 1 | 1 | 1 | 1 | 1 | 1 |
| | Green | 0 | 0 | 0 | 0 | 0 | 0 | 0 | 0 | 1 | 1 | 1 | 1 | 1 | 1 | 1 | 1 | 0 | 0 | 0 | 0 | 0 | 0 | 0 | 0 |
| | Cyan | 0 | 0 | 0 | 0 | 0 | 0 | 0 | 0 | 1 | 1 | 1 | 1 | 1 | 1 | 1 | 1 | 1 | 1 | 1 | 1 | 1 | 1 | 1 | 1 |
| | Red | 1 | 1 | 1 | 1 | 1 | 1 | 1 | 1 | 0 | 0 | 0 | 0 | 0 | 0 | 0 | 0 | 0 | 0 | 0 | 0 | 0 | 0 | 0 | 0 |
| | Magenta | 1 | 1 | 1 | 1 | 1 | 1 | 1 | 1 | 0 | 0 | 0 | 0 | 0 | 0 | 0 | 0 | 1 | 1 | 1 | 1 | 1 | 1 | 1 | 1 |
| | Yellow | 1 | 1 | 1 | 1 | 1 | 1 | 1 | 1 | 1 | 1 | 1 | 1 | 1 | 1 | 1 | 1 | 0 | 0 | 0 | 0 | 0 | 0 | 0 | 0 |
| | White | 1 | 1 | 1 | 1 | 1 | 1 | 1 | 1 | 1 | 1 | 1 | 1 | 1 | 1 | 1 | 1 | 1 | 1 | 1 | 1 | 1 | 1 | 1 | 1 |
| Gray Scale of Red | Black | 0 | 0 | 0 | 0 | 0 | 0 | 0 | 0 | 0 | 0 | 0 | 0 | 0 | 0 | 0 | 0 | 0 | 0 | 0 | 0 | 0 | 0 | 0 | |
| | △ | 0 | 0 | 0 | 0 | 0 | 0 | 0 | 1 | 0 | 0 | 0 | 0 | 0 | 0 | 0 | 0 | 0 | 0 | 0 | 0 | 0 | 0 | 0 | |
| | Darker | 0 | 0 | 0 | 0 | 0 | 0 | 1 | 0 | 0 | 0 | 0 | 0 | 0 | 0 | 0 | 0 | 0 | 0 | 0 | 0 | 0 | 0 | 0 | |
| | △ | | | | | | | | | | | | | | | | | | | | | | | | |
| | ▽ | | | | | | | | | | | | | | | | | | | | | | | | |
| | Brighter | 1 | 1 | 1 | 1 | 1 | 1 | 0 | 1 | 0 | 0 | 0 | 0 | 0 | 0 | 0 | 0 | 0 | 0 | 0 | 0 | 0 | 0 | 0 | |
| | ▽ | 1 | 1 | 1 | 1 | 1 | 1 | 1 | 0 | 0 | 0 | 0 | 0 | 0 | 0 | 0 | 0 | 0 | 0 | 0 | 0 | 0 | 0 | 0 | |
| | Red | 1 | 1 | 1 | 1 | 1 | 1 | 1 | 1 | 0 | 0 | 0 | 0 | 0 | 0 | 0 | 0 | 0 | 0 | 0 | 0 | 0 | 0 | 0 | 0 |
| Gray Scale of Green | Black | 0 | 0 | 0 | 0 | 0 | 0 | 0 | 0 | 0 | 0 | 0 | 0 | 0 | 0 | 0 | 0 | 0 | 0 | 0 | 0 | 0 | 0 | 0 | |
| | △ | 0 | 0 | 0 | 0 | 0 | 0 | 0 | 0 | 0 | 0 | 0 | 0 | 0 | 0 | 0 | 1 | 0 | 0 | 0 | 0 | 0 | 0 | 0 | |
| | Darker | 0 | 0 | 0 | 0 | 0 | 0 | 0 | 0 | 0 | 0 | 0 | 0 | 0 | 0 | 1 | 0 | 0 | 0 | 0 | 0 | 0 | 0 | 0 | |
| | △ | | | | | | | | | | | | | | | | | | | | | | | | |
| | ▽ | | | | | | | | | | | | | | | | | | | | | | | | |
| | Brighter | 0 | 0 | 0 | 0 | 0 | 0 | 0 | 0 | 1 | 1 | 1 | 1 | 1 | 1 | 0 | 1 | 0 | 0 | 0 | 0 | 0 | 0 | 0 | |
| | ▽ | 0 | 0 | 0 | 0 | 0 | 0 | 0 | 0 | 1 | 1 | 1 | 1 | 1 | 1 | 1 | 0 | 0 | 0 | 0 | 0 | 0 | 0 | 0 | |
| | Green | 0 | 0 | 0 | 0 | 0 | 0 | 0 | 0 | 1 | 1 | 1 | 1 | 1 | 1 | 1 | 1 | 0 | 0 | 0 | 0 | 0 | 0 | 0 | 0 |
| Gray Scale of Blue | Black | 0 | 0 | 0 | 0 | 0 | 0 | 0 | 0 | 0 | 0 | 0 | 0 | 0 | 0 | 0 | 0 | 0 | 0 | 0 | 0 | 0 | 0 | 0 | |
| | △ | 0 | 0 | 0 | 0 | 0 | 0 | 0 | 0 | 0 | 0 | 0 | 0 | 0 | 0 | 0 | 0 | 0 | 0 | 0 | 0 | 0 | 0 | 1 | |
| | Darker | 0 | 0 | 0 | 0 | 0 | 0 | 0 | 0 | 0 | 0 | 0 | 0 | 0 | 0 | 0 | 0 | 0 | 0 | 0 | 0 | 0 | 0 | 1 | |
| | △ | | | | | | | | | | | | | | | | | | | | | | | | |
| | ▽ | | | | | | | | | | | | | | | | | | | | | | | | |
| | Brighter | 0 | 0 | 0 | 0 | 0 | 0 | 0 | 0 | 0 | 0 | 0 | 0 | 0 | 0 | 0 | 1 | 1 | 1 | 1 | 1 | 1 | 1 | 0 | |
| | ▽ | 0 | 0 | 0 | 0 | 0 | 0 | 0 | 0 | 0 | 0 | 0 | 0 | 0 | 0 | 0 | 1 | 1 | 1 | 1 | 1 | 1 | 1 | 0 | |
| | Blue | 0 | 0 | 0 | 0 | 0 | 0 | 0 | 0 | 0 | 0 | 0 | 0 | 0 | 0 | 0 | 1 | 1 | 1 | 1 | 1 | 1 | 1 | 1 | |
| Gray Scale of White | Black | 0 | 0 | 0 | 0 | 0 | 0 | 0 | 0 | 0 | 0 | 0 | 0 | 0 | 0 | 0 | 0 | 0 | 0 | 0 | 0 | 0 | 0 | 0 | |
| | △ | 0 | 0 | 0 | 0 | 0 | 0 | 0 | 1 | 0 | 0 | 0 | 0 | 0 | 0 | 0 | 1 | 0 | 0 | 0 | 0 | 0 | 0 | 1 | |
| | Darker | 0 | 0 | 0 | 0 | 0 | 0 | 1 | 0 | 0 | 0 | 0 | 0 | 0 | 0 | 1 | 0 | 0 | 0 | 0 | 0 | 0 | 0 | 1 | |
| | △ | | | | | | | | | | | | | | | | | | | | | | | | |
| | ▽ | | | | | | | | | | | | | | | | | | | | | | | | |
| | Brighter | 1 | 1 | 1 | 1 | 1 | 1 | 0 | 1 | 1 | 1 | 1 | 1 | 1 | 1 | 0 | 1 | 1 | 1 | 1 | 1 | 1 | 1 | 0 | |
| | ▽ | 1 | 1 | 1 | 1 | 1 | 1 | 1 | 0 | 1 | 1 | 1 | 1 | 1 | 1 | 1 | 0 | 1 | 1 | 1 | 1 | 1 | 1 | 0 | |
| | White | 1 | 1 | 1 | 1 | 1 | 1 | 1 | 1 | 1 | 1 | 1 | 1 | 1 | 1 | 1 | 1 | 1 | 1 | 1 | 1 | 1 | 1 | 1 | |

5.4 Power Sequence

To prevent a latch-up or DC operation of the Open Cell, the power on/off sequence shall be as shown in below

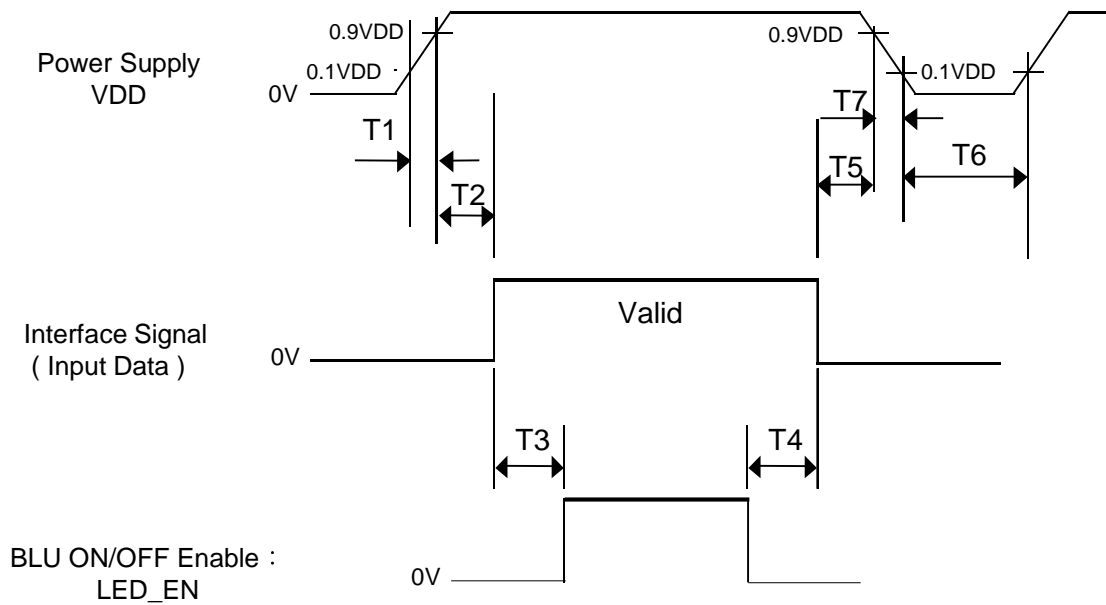

< Table 11. Sequence Table >

| Parameter | Values | | | Units |
|-----------|--------|-----|-----|-------|
| | Min | Typ | Max | |
| T1 | 0.5 | - | 20 | ms |
| T2 | 10 | - | 100 | ms |
| T3 | 200 | - | - | ms |
| T4 | 200 | - | - | ms |
| T5 | 0 | - | - | ms |
| T6 | 1 | - | - | s |

- Notes:
1. Back Light must be turn on after power for logic and interface signal are valid.
 2. Even though T1 is out of SPEC, it is still ok if the inrush current of VDD is below the limit.
 3. When $VDD < 0.9VDD(Typ.)$, Power off.
 4. T7 decreases smoothly, if there were rebounding voltage, it must smaller than 5 volts.

| | | | |
|---|---|------------------|------------|
| BOE | PRODUCT GROUP | REV | ISSUE DATE |
| | TFT- LCD PRODUCT | P0 | 2017.07.01 |
| SPEC. NUMBER NO. S8-65-8D-001 | SPEC. TITLE DV210FBM-N00 Product Specification | PAGE 19 OF 27 | |

6.0 OPTICAL SPECIFICATIONS

The test of optical specifications shall be measured in a dark room (ambient luminance \leq 1 lux and temperature= $25\pm 2^{\circ}\text{C}$) with the equipment of Luminance meter system (Goniometer system and PR730) and test unit shall be located at an approximate distance 180cm from the LCD surface at a viewing angle of θ and Φ equal to 0° . We refer to $\theta_{\Phi=0}$ ($=\theta_3$) as the 3 o'clock direction (the "right"), $\theta_{\Phi=90}$ ($=\theta_{12}$) as the 12 o'clock direction ("upward"), $\theta_{\Phi=180}$ ($=\theta_9$) as the 9 o'clock direction ("left") and $\theta_{\Phi=270}$ ($=\theta_6$) as the 6 o'clock direction ("bottom"). While scanning θ and/or Φ , the center of the measuring spot on the Display surface shall stay fixed. The measurement shall be executed after 30 minutes warm-up period. VDD shall be 12.0V at 25°C . Optimum viewing angle direction is 6 'clock.

< Table 12. Optical Table >

[VDD = 12.0V, Frame rate = 60Hz, Ta = $25\pm 2^{\circ}\text{C}$]

| Parameter | | Symbol | Condition | Min | Typ | Max | Unit | Remark |
|-----------------------|------------|---------------|--|----------------|--------|----------------|------|--------|
| Viewing Angle | Horizontal | θ_3 | CR > 10 | | 89 | | Deg. | Note 1 |
| | | θ_9 | | | 89 | | Deg. | |
| | Vertical | θ_{12} | | | 89 | | Deg. | |
| | | θ_6 | | | 89 | | Deg. | |
| Brightness | | Lv | | 250 | 300 | | nit | |
| Contrast ratio | | CR | | 800:1 | 1200:1 | - | | Note 2 |
| Reproduction of color | White | W_x | $\theta = 0^{\circ}$ (Center) Normal Viewing Angle | TYP. - 0.03 | 0.313 | TYP. + 0.03 | | Note 3 |
| | | W_y | | | 0.329 | | | |
| | Red | R_x | | | 0.643 | | | |
| | | R_y | | | 0.328 | | | |
| | Green | G_x | | | 0.303 | | | |
| | | G_y | | | 0.619 | | | |
| | Blue | B_x | | | 0.154 | | | |
| | | B_y | | | 0.067 | | | |
| Response Time | G to G | T_g | | - | 8 | 10 | ms | Note 4 |
| Gamma Scale | | | | 2.0 | 2.2 | 2.4 | | |
| Cell Transmittance | | | | 5.9 | 5.15% | | % | Note 5 |

| | | | |
|---|---|-----|------------------|
| BOE | PRODUCT GROUP | REV | ISSUE DATE |
| | TFT- LCD PRODUCT | P0 | 2017.07.01 |
| SPEC. NUMBER NO. S8-65-8D-001 | SPEC. TITLE DV210FBM-N00 Product Specification | | PAGE 20 OF 27 |

Note :

- Viewing angle is the angle at which the contrast ratio is greater than 10. The viewing are determined for the horizontal or 3, 9 o'clock direction and the vertical or 6, 12 o'clock direction with respect to the optical axis which is normal to the LCD surface.
- Contrast measurements shall be made at viewing angle of $\theta = 0^\circ$ and at the center of the LCD surface. Luminance shall be measured with all pixels in the view field set first to white, then to the dark (black) state. (See Figure 1 shown in Appendix) Luminance Contrast Ratio (CR) is defined mathematically.

$$CR = \frac{\text{Luminance when displaying a white raster}}{\text{Luminance when displaying a black raster}}$$

- The color chromaticity coordinates specified in Table 9 shall be calculated from the spectral data measured with all pixels first in red, green, blue and white. Measurements shall be made at the center of the panel. The BLU is used by BOE.
- Response time T_g is the average time required for display transition by switching the input signal as below table and is based on Frame rate $f_V = 60\text{Hz}$ to optimize.

Each time in below table is defined as Figure 2 and shall be measured by switching the

| Measured Response Time | Target | | | | | | | | | | | | | | | | |
|------------------------|--------|----|----|----|----|----|----|-----|-----|-----|-----|-----|-----|-----|-----|-----|-----|
| | 0 | 15 | 31 | 47 | 63 | 79 | 95 | 111 | 127 | 143 | 159 | 175 | 191 | 207 | 223 | 239 | 255 |
| 0 | | | | | | | | | | | | | | | | | |
| 15 | | | | | | | | | | | | | | | | | |
| 31 | | | | | | | | | | | | | | | | | |
| 47 | | | | | | | | | | | | | | | | | |
| 63 | | | | | | | | | | | | | | | | | |
| 79 | | | | | | | | | | | | | | | | | |
| 95 | | | | | | | | | | | | | | | | | |
| 111 | | | | | | | | | | | | | | | | | |
| 127 | | | | | | | | | | | | | | | | | |
| 143 | | | | | | | | | | | | | | | | | |
| 159 | | | | | | | | | | | | | | | | | |
| 175 | | | | | | | | | | | | | | | | | |
| 191 | | | | | | | | | | | | | | | | | |
| 207 | | | | | | | | | | | | | | | | | |
| 223 | | | | | | | | | | | | | | | | | |
| 239 | | | | | | | | | | | | | | | | | |
| 255 | | | | | | | | | | | | | | | | | |

5. Definition of Transmittance (T%) :

Module is with white(L255) signal input

$$\text{Transmittance} = \frac{\text{Luminance of LCD Module}}{\text{Luminance of BLU}} \times 100 \%$$

| | | | |
|---|---|-----|------------------|
| BOE | PRODUCT GROUP | REV | ISSUE DATE |
| | TFT- LCD PRODUCT | P0 | 2017.07.01 |
| SPEC. NUMBER NO. S8-65-8D-001 | SPEC. TITLE DV210FBM-N00 Product Specification | | PAGE 21 OF 27 |

7.0 MECHANICAL CHARACTERISTICS

7.1 Dimensional Requirements

Figure 3(located in Appendix) shows mechanical outlines for the model HV430FHB-N10. Other parameters are shown in Table 13.

< Table 13. Dimensional Parameters >

| Parameter | Specification | Unit |
|---------------------|---|--------|
| Dimensional outline | 542.4(H) × 52.7(V) × 8.0(B) | mm |
| Weight | TBD(typ.) | gram |
| Active area | 529.416(H) × 36.39735(V) | mm |
| Pixel pitch | 91.9125(H) × 275.7375(V) | mm |
| Number of pixels | 1920(H) × 132(V) (1 pixel = R + G + B dots) | pixels |
| Back-light | Up edge side 1-LED Light bar Type | |

7.2 Mounting

See FIGURE 5. (shown in Appendix)

7.3 Anti-Glare and Polarizer Hardness.

The surface of the LCD has an anti-glare coating to minimize reflection and a coating to reduce scratching.

| | | | |
|---|---|-----|------------------|
| BOE | PRODUCT GROUP | REV | ISSUE DATE |
| | TFT- LCD PRODUCT | P0 | 2017.07.01 |
| SPEC. NUMBER NO. S8-65-8D-001 | SPEC. TITLE DV210FBM-N00 Product Specification | | PAGE 22 OF 27 |

8.0 RELIABILITY TEST

The Reliability test items and its conditions are shown in below.

< Table 14. Reliability Test Parameters >

| No | Test Items | Conditions |
|----|---|---|
| 1 | High temperature storage test | Ta = 60 °C, 240 hrs |
| 2 | Low temperature storage test | Ta = -20 °C, 240 hrs |
| 3 | High temperature & high humidity operation test | Ta = 50 °C, 80%RH, 240hrs |
| 4 | High temperature operation test | Ta = 50 °C, 240hrs |
| 5 | Low temperature operation test | Ta = -5 °C, 240hrs |
| 6 | Thermal shock | Ta = -20 °C ↔ 60 °C (0.5 hr), 100 cycle |

This test condition is based on BOE module.

| | | | |
|---|---|-----|------------------|
| BOE | PRODUCT GROUP | REV | ISSUE DATE |
| | TFT- LCD PRODUCT | P0 | 2017.07.01 |
| SPEC. NUMBER NO. S8-65-8D-001 | SPEC. TITLE DV210FBM-N00 Product Specification | | PAGE 23 OF 27 |

9.0 PRODCUT SERIAL NUMBER

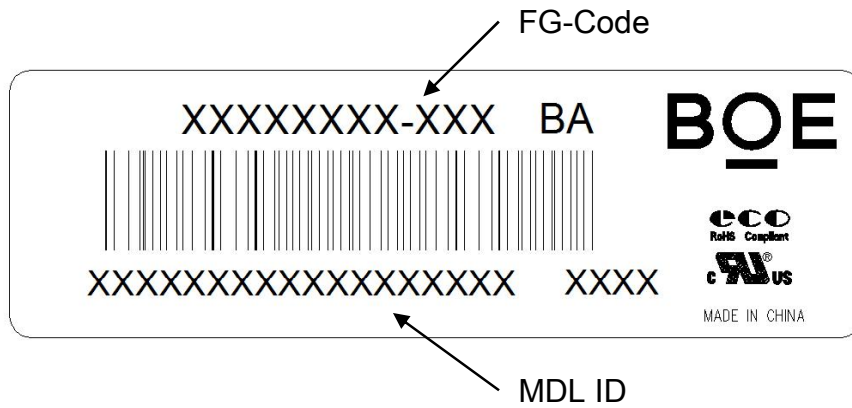

MDL ID Naming Rule:

| | | | | | | | | | | | |
|---------------|-------------------|----|-------|------|------|----|---------------|----------------------|---|----|----|
| Digit Code | 1 | 2 | 3 | 4 | 5 | 6 | 7 | 8 | 9 | 10 | 11 |
| Description | Model Code GBN | | Grade | Line | Year | | Month | Model Extension Code | | | |
| Digit Code | 12 | 13 | 14 | 15 | 16 | 17 | 18 | | | | |
| Description | Serial No | | | | | | 扫码不显示, BOE厂内用 | | | | |

| | | | |
|---|---|-----|------------------|
| BOE | PRODUCT GROUP | REV | ISSUE DATE |
| | TFT- LCD PRODUCT | P0 | 2017.07.01 |
| SPEC. NUMBER NO. S8-65-8D-001 | SPEC. TITLE DV210FBM-N00 Product Specification | | PAGE 24 OF 27 |

10.0 PACKING INFORMATION

BOE provides the standard shipping container for customers, unless customer specifies their packing information. The standard packing method and Barcode information are shown in below.

10.1 Packing Order

Put 1 EPO bottom into the inner box.



Put each module into a PE bag.
Insert 8 Pcs MDL into each box

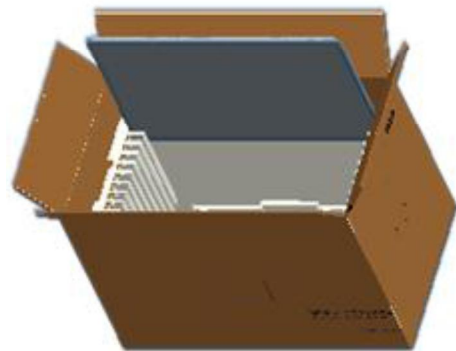

Put totally 36 boxes. Place paper corners and wrap film around the boxes. Pack with 4 packing belts.

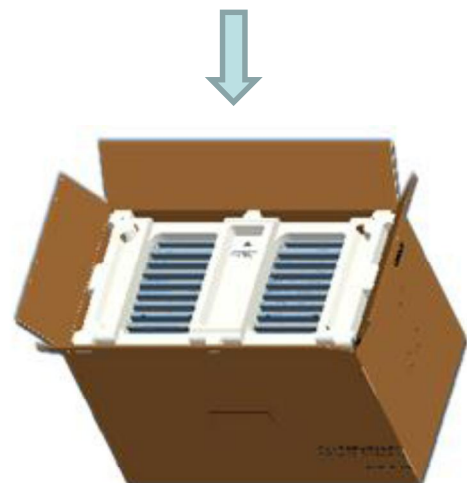

Put 1 EPO cover in and seal the box.

| | | | |
|---|---|------------------|------------|
| BOE | PRODUCT GROUP | REV | ISSUE DATE |
| | TFT- LCD PRODUCT | P0 | 2017.07.01 |
| SPEC. NUMBER NO. S8-65-8D-001 | SPEC. TITLE DV210FBM-N00 Product Specification | PAGE 25 OF 27 | |

10.2 Packing Note

- Box Dimension : 639mm(L)×310mm(W)×142mm(H)
- Package Quantity in one Box : 8pcs

10.3 Box Label

- Label Size : 100 mm (L) × 50 mm (W)
 - Contents

Model : DV210FBM-N00

Q`ty : Module 8 Q`ty in one box

Serial No. : Box Serial No.

Date : Packing Date

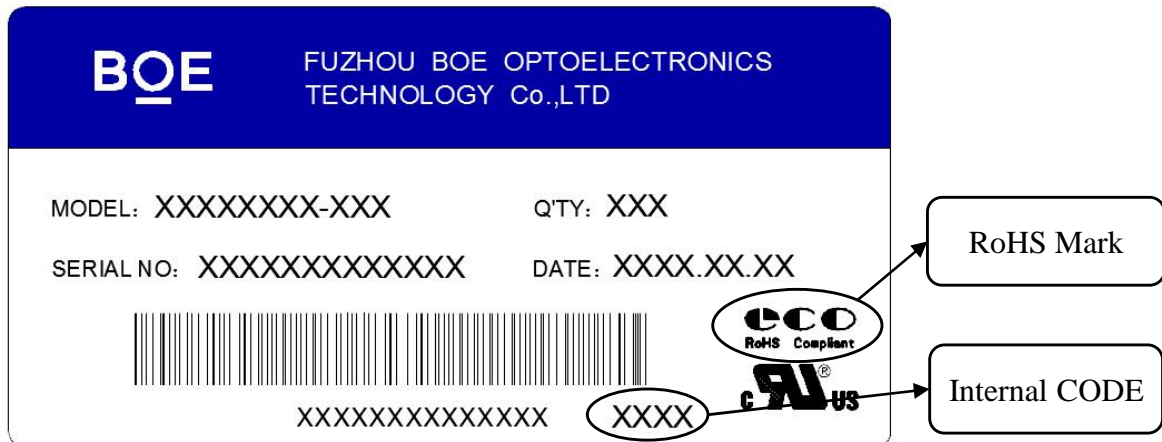

| Digit | 1 | 2 | 3 | 4 | 5 | 6 | 7 | | | | | | | |
|-------|--|---|---|---|---|---|---|---|---|---|---|---|---|--|
| Code | x | x | x | x | x | x | x | x | x | x | x | x | x | |
| Des. | 1. Model Code GBN 2. Grade 3. Line 4. Year(2016:16, 2017:17, ...) 5. Month(1, 2, 3, ..., 9, X, Y, Z) 6. Revision Code 7. Serial Number | | | | | | | | | | | | | |

| | | | |
|---|---|-----|------------------|
| BOE | PRODUCT GROUP | REV | ISSUE DATE |
| | TFT- LCD PRODUCT | P0 | 2017.07.01 |
| SPEC. NUMBER NO. S8-65-8D-001 | SPEC. TITLE DV210FBM-N00 Product Specification | | PAGE 26 OF 27 |

11.0 HANDLING & CAUTIONS

- (1) Cautions when taking out the module
 - Pick the pouch only, when taking out module from a shipping package.
- (2) Cautions for handling the module
 - As the electrostatic discharges may break the LCD module, handle the LCD module with care. Peel a protection sheet off from the LCD panel surface as slowly as possible.
 - As the LCD panel and back - light element are made from fragile glass material, impulse and pressure to the LCD module should be avoided.
 - As the surface of the polarizer is very soft and easily scratched, use a soft dry cloth without chemicals for cleaning.
 - Do not pull the interface connector in or out while the LCD module is operating.
 - Put the module display side down on a flat horizontal plane.
 - Handle connectors and cables with care.
- (3) Cautions for the operation
 - When the module is operating, do not lose CLK, ENAB signals. If any one of these signals is lost, the LCD panel would be damaged.
 - Obey the supply voltage sequence. If wrong sequence is applied, the module would be damaged.
- (4) Cautions for the atmosphere
 - Dew drop atmosphere should be avoided.
 - Do not store and/or operate the LCD module in a high temperature and/or humidity atmosphere. Storage in an electro-conductive polymer packing pouch and under relatively low temperature atmosphere is recommended.
- (5) Cautions for the module characteristics
 - Do not apply fixed pattern data signal to the LCD module at product aging.
 - Applying fixed pattern for a long time may cause image sticking.
- (6) Other cautions
 - Do not disassemble and/or re-assemble LCD module.
 - Do not re-adjust variable resistor or switch etc.
 - When returning the module for repair or etc., Please pack the module not to be broken. We recommend to use the original shipping packages.

| | | | |
|---|---|-----|------------------|
| BOE | PRODUCT GROUP | REV | ISSUE DATE |
| | TFT- LCD PRODUCT | P0 | 2017.07.01 |
| SPEC. NUMBER NO. S8-65-8D-001 | SPEC. TITLE DV210FBM-N00 Product Specification | | PAGE 27 OF 27 |

12.0 APPENDIX

< Figure 1. Measurement Set Up >

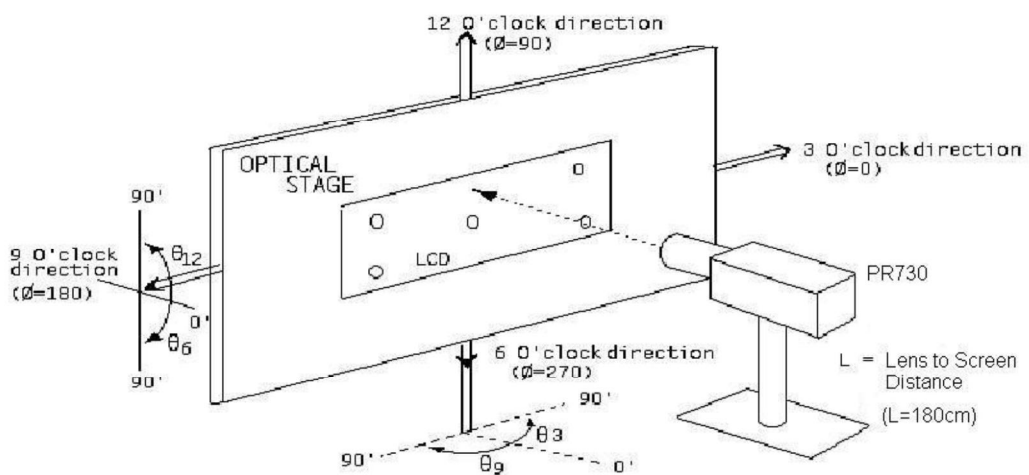

< Figure 2. Response Time Testing >

Any level of gray (Bright)

Any level of gray (Dark)

Any level of gray (Bright)

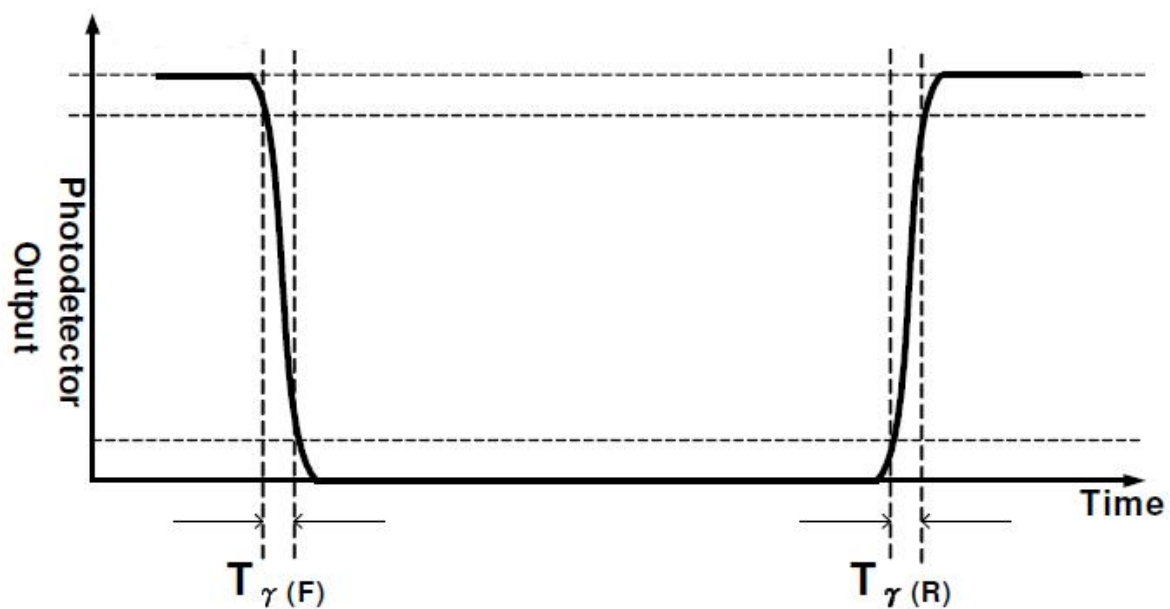

< Figure 3.TFT-LCD Module Outline Dimensions (Front View) >

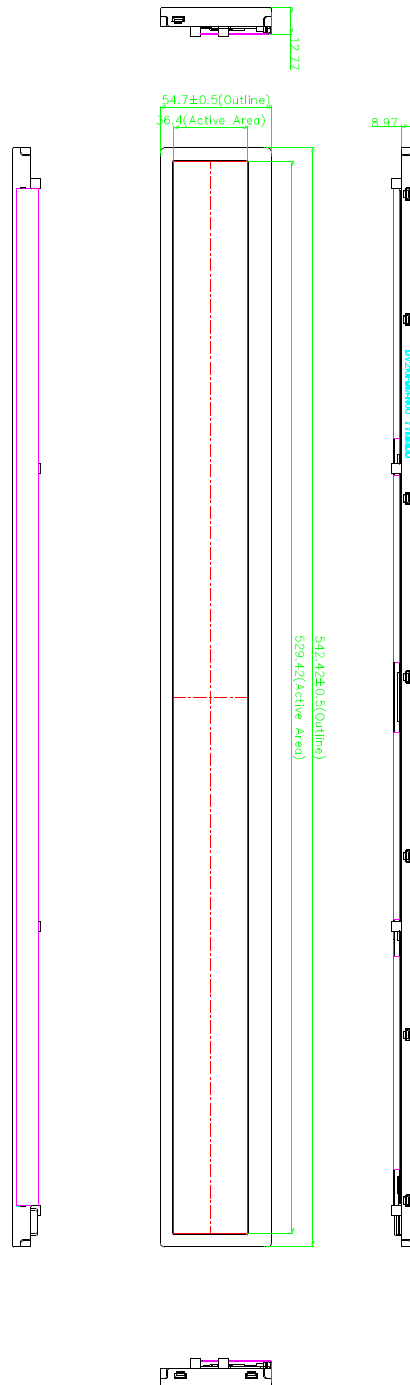

< Figure 4.TFT-LCD Module Outline Dimensions (Rear View) >

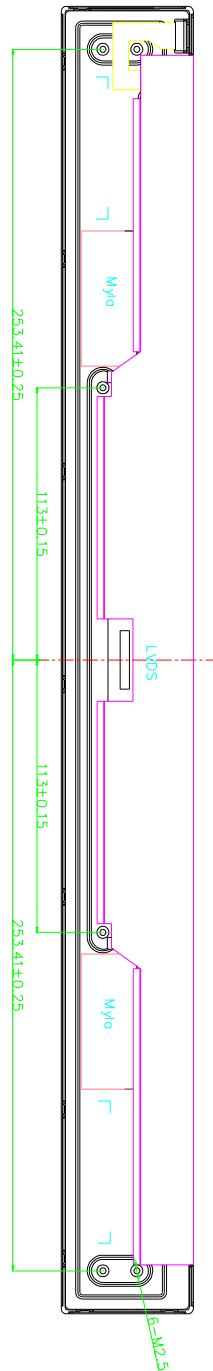

DATA MODUL



ALL TECHNOLOGIES. ALL COMPETENCIES. ONE SPECIALIST.



DATA MODUL AG
Landsberger Straße 322
DE-80687 Munich
Phone: +49-89-56017-0

DATA MODUL WEIKERSHEIM GMBH
Lindenstraße 8
DE-97990 Weikersheim
Phone: +49-7934-101-0



More information and worldwide locations can be found at

www.data-modul.com