



AUO Display+

# Product Specification

G121XTN02.0

( V ) Preliminary Specifications

( ) Final Specifications

<b>Module</b>	12.1 Inch Color TFT-LCD
<b>Model Name</b>	G121XTN02.0
<b>Model Version</b>	

<b>Customer</b>	<b>Date</b>
_____	_____
<b>Checked &amp; Approved by</b>	
_____	_____

<b>Approved by</b>	<b>Date</b>
Ginger Lin _____	2024/09/30 _____
<b>Prepared by</b>	
Ken Wang _____	2024/09/30 _____
General Display Business Unit / AUO Display Plus Corporation	

## Contents

<b>1. Operating Precautions .....</b>	<b>4</b>
<b>2. General Description .....</b>	<b>5</b>
2.1 Display Characteristics.....	5
2.2 Optical Characteristics .....	6
<b>3. Functional Block Diagram.....</b>	<b>9</b>
<b>4. Absolute Maximum Ratings.....</b>	<b>10</b>
4.1 Absolute Ratings of TFT LCD Module.....	10
4.2 Absolute Ratings of Environment.....	10
<b>5. Electrical Characteristics .....</b>	<b>11</b>
5.1 TFT LCD Module.....	11
<b>6. Signal Characteristics .....</b>	<b>14</b>
6.1 Pixel Format Image .....	14
6.2 Scanning Direction.....	14
6.3 TFT-LCD Interface Signal Description.....	15
6.4 The Input Data Format .....	16
6.5 TFT-LCD Interface Timing.....	17
6.6 Power ON/OFF Sequence .....	18
<b>7. Connector &amp; Pin Assignment .....</b>	<b>19</b>
7.1 TFT-LCD Signal (CN1): LCD Connector .....	19
7.2 LED Backlight Unit (CN2): Driver Connector.....	19
<b>8. Reliability Test Criteria .....</b>	<b>20</b>
<b>9. Mechanical Characteristics.....</b>	<b>21</b>
<b>9.1 LCM Outline Dimension (Front View) .....</b>	<b>21</b>
<b>9.2 LCM Outline Dimension (Rear View).....</b>	<b>22</b>
<b>10. Label and Packaging .....</b>	<b>23</b>
10.1 Shipping Label (on the rear side of TFT-LCD display) .....	23
10.2 Carton Package .....	23
<b>11 Safety.....</b>	<b>24</b>
11.1 Keen Edge Requirements .....	24
11.2 Materials.....	24



## 1. Operating Precautions

- 1) Since front polarizer is easily damaged, please be cautious and not to scratch it.
- 2) Be sure to turn off power supply when inserting or disconnecting from input connector.
- 3) Wipe off water drop immediately. Long contact with water may cause discoloration or spots.
- 4) When the panel surface is soiled, wipe it with absorbent cotton or soft cloth.
- 5) Since the panel is made of glass, it may be broken or cracked if dropped or bumped on hard surface.
- 6) To avoid ESD (Electro Static Discharge) damage, be sure to ground yourself before handling TFT-LCD Module.
- 7) Do not open nor modify the module assembly.
- 8) Do not press the reflector sheet at the back of the module to any direction.
- 9) In case if a module has to be put back into the packing container slot after it was taken out from the container, do not press the center of the LED light bar edge. Instead, press at the far ends of the LED light bar edge softly. Otherwise the TFT Module may be damaged.
- 10) At the insertion or removal of the Signal Interface Connector, be sure not to rotate nor tilt the Interface Connector of the TFT Module.
- 11) TFT-LCD Module is not allowed to be twisted & bent even force is added on module in a very short time. Please design your display product well to avoid external force applying to module by end-user directly.
- 12) Small amount of materials without flammability grade are used in the TFT-LCD module. The TFT-LCD module should be supplied by power complied with requirements of Limited Power Source (IEC60950 or UL1950), or be applied exemption.
- 13) Severe temperature condition may result in different luminance, response time and lamp ignition voltage.
- 14) Continuous operating TFT-LCD display under low temperature environment may accelerate lamp exhaustion and reduce luminance dramatically.
- 15) The data on this specification sheet is applicable when LCD module is placed in landscape position.
- 16) Continuous displaying fixed pattern may induce image sticking. It's recommended to use screen saver or shuffle content periodically if fixed pattern is displayed on the screen.

## 2. General Description

This specification applies to the Color Active Matrix Liquid Crystal Display G121XTN02.0 composed of a TFT-LCD display, a driver and power supply circuit, and a LED backlight system. The screen format is intended to support XGA (1024(H) x 768(V)) screen and 16.7M (RGB 8-bits) or 262k colors (RGB 6-bits).

LED driving board for backlight unit is included in G121XTN02.0.

All input signals are LVDS interface and compatible.

G121XTN02.0 designed with wide viewing angle; wide temperature and long life LED backlight is well suited for industrial applications.

G121XTN02.0 is a RoHS product.

### 2.1 Display Characteristics

The following items are characteristics summary on the table under 25 °C condition:

Items	Unit	Specifications
Screen Diagonal	[inch]	12.1
Active Area	[mm]	245.76 (H) x 184.32 (V)
Pixels H x V		1024 x 768
Pixel Pitch	[mm]	0.24 x 0.24
Pixel Arrangement		R.G.B. Vertical Stripe
Display Mode		TN, Normally White
Nominal Input Voltage VDD	[Volt]	3.3 (typ.)
Typical Power Consumption	[Watt]	10.3(typ.)
Weight	[Grams]	490 (Max.)
Physical Size	[mm]	260.5(H) x 204.0(V) x 9.0(D) (TYP.)
Electrical Interface		1 channel LVDS
Surface Treatment		Anti-glare, Hardness 3H
Support Color		16.2M / 262K colors
Temperature Range		
Operating	[°C]	-30 to +85
Storage (Non-Operating)	[°C]	-30 to +85
RoHS Compliance		RoHS Compliance

## 2.2 Optical Characteristics

The optical characteristics are measured under stable conditions at 25°C (Room Temperature):

Item	Unit	Conditions	Min.	Typ.	Max.	Remark
White Luminance	[cd/m <sup>2</sup> ]	I <sub>F</sub> = 81 mA/1 LED Line (center point)	800	1000	-	Note 1
Uniformity	%	5 Points	75	-	-	Note 2, 3
Contrast Ratio			500	700	-	Note 4
Response Time	[msec]	Rising	-	25	35	Note 5
	[msec]	Falling	-	10	20	
	[msec]	Raising + Falling	-	35	55	
Viewing Angle	[degree] [degree]	Horizontal (Right) CR = 10 (Left)	70 70	80 80	- -	Note 6
	[degree] [degree]	Vertical (Upper) CR = 10 (Lower)	60 60	70 70	- -	
Color / Chromaticity Coordinates (CIE 1931)		Red x				
		Red y				
		Green x				
		Green y				
		Blue x				
		Blue y				
		White x		0.260	0.310	0.360
	White y		0.280	0.330	0.380	
Color Gamut	%		-	72	-	

Note 1: Measurement method

Equipment Pattern Generator, Power Supply, Digital Voltmeter, Luminance meter (SR\_3 or equivalent)

Aperture 1° with 50cm viewing distance

Test Point Center

Environment < 1 lux

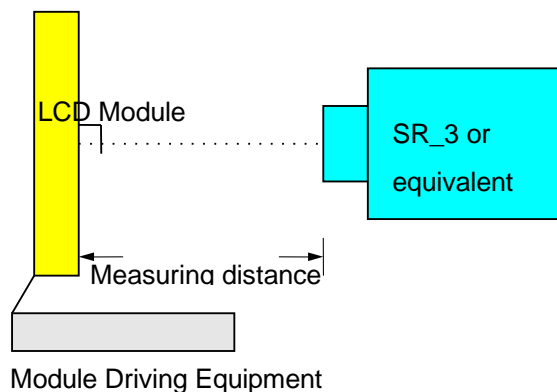

Note 2: Definition of 5 points position (Display active area: 245.76mm (H) x 184.32mm (V))

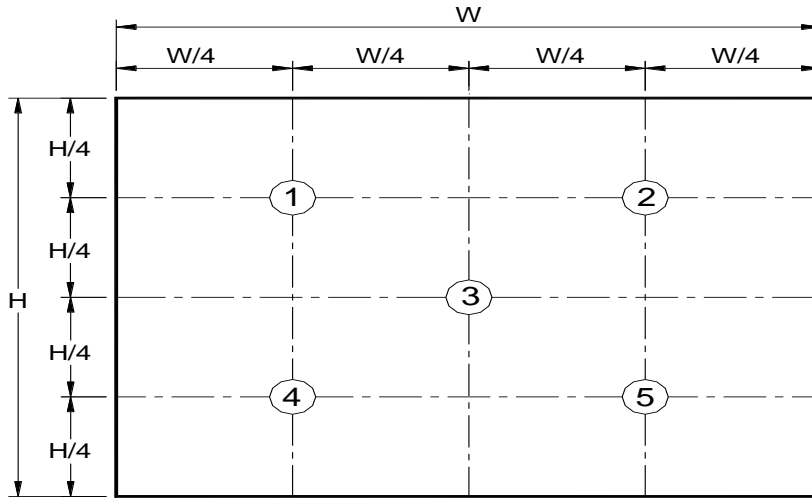

Note 3: The luminance uniformity of 5 points is defined by dividing the minimum luminance values by the maximum test point luminance

$$\delta_{w9} = \frac{\text{Minimum Brightness of five points}}{\text{Maximum Brightness of five points}}$$

Note 4: Definition of contrast ratio (CR):

$$\text{Contrast ratio (CR)} = \frac{\text{Brightness on the "White" state}}{\text{Brightness on the "Black" state}}$$

Note 5: Definition of response time:

The output signals of photo detector are measured when the input signals are changed from "White" to "Black" (falling time) and from "Black" to "White" (rising time), respectively. The response time interval is between 10% and 90% of amplitudes. Please refer to the figure as below.

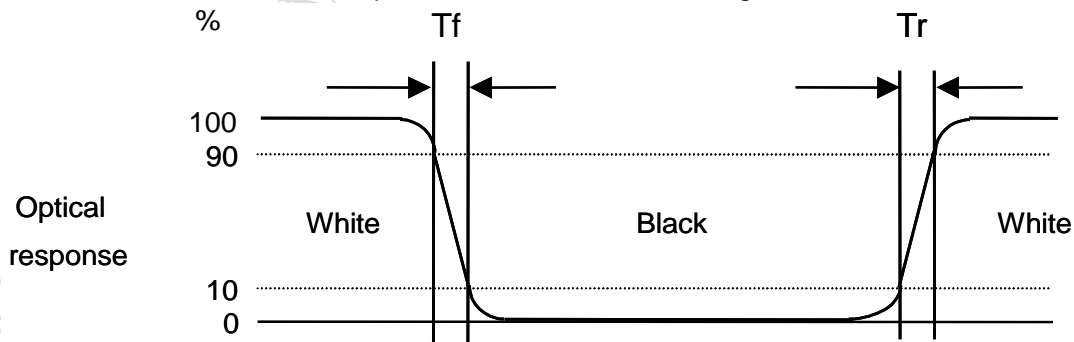

Note 6: Definition of viewing angle

Viewing angle is the measurement of contrast ratio  $\geq 10$ , at the screen center, over a 180° horizontal and 180° vertical range (off-normal viewing angles). The 180° viewing angle range is broken down as below:

## AUO Display+

90° ( $\theta$ ) horizontal left and right, and 90° ( $\Phi$ ) vertical high (up) and low (down). The measurement direction is typically perpendicular to the display surface with the screen rotated to its center to develop the desired measurement viewing angle.

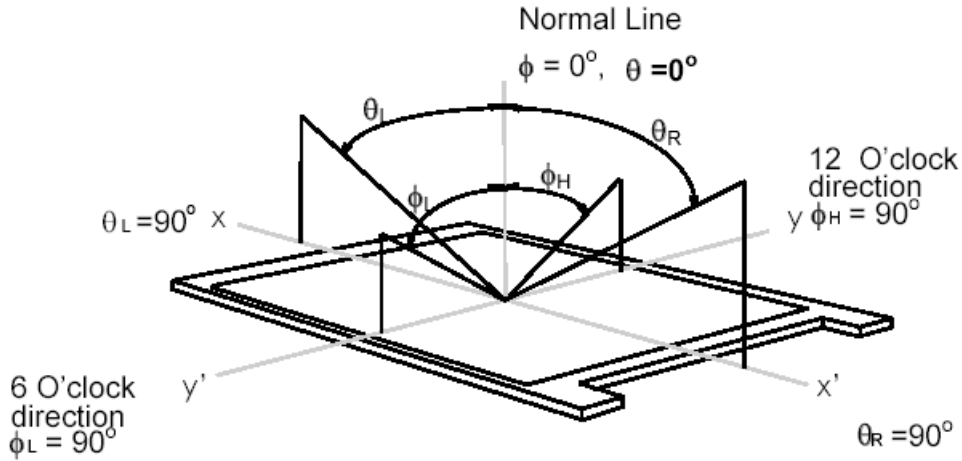

USE ONLY

ADP CONFIDENTIAL FOR PROMATE

## 3. Functional Block Diagram

The following diagram shows the functional block of the 12.1 inch color TFT/LCD module:

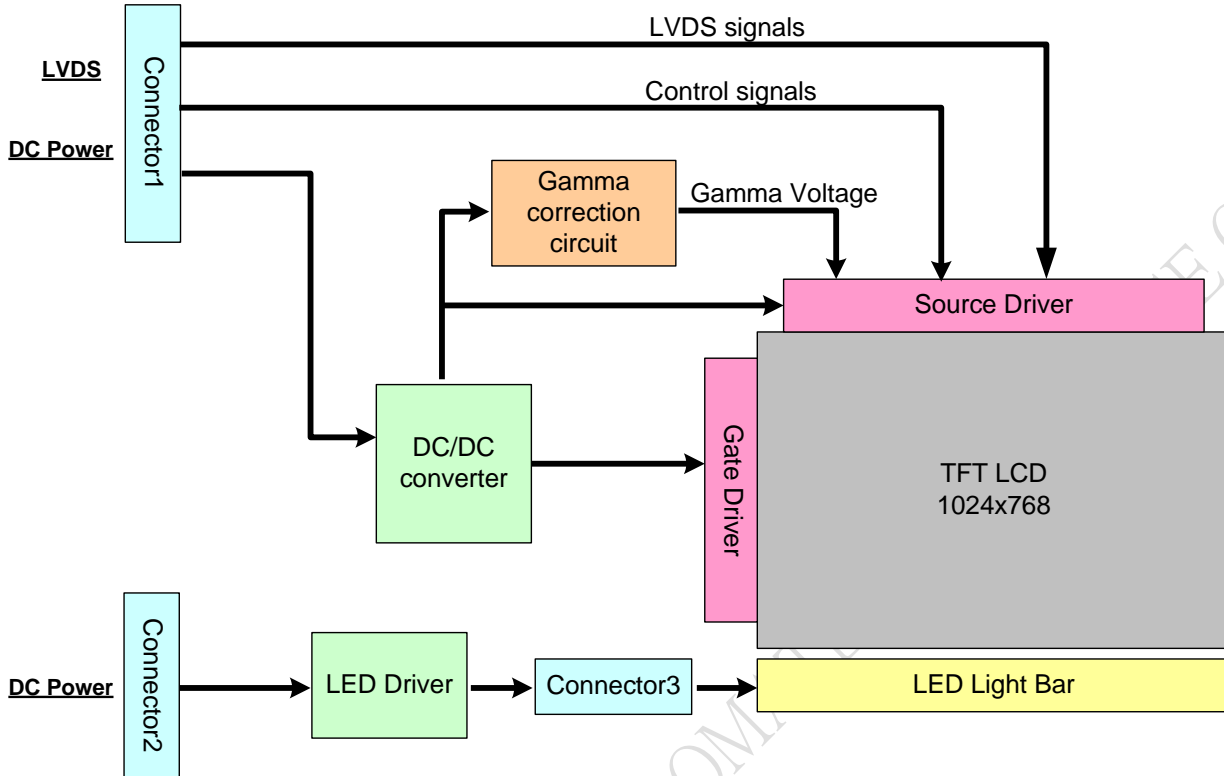

## 4. Absolute Maximum Ratings

### 4.1 Absolute Ratings of TFT LCD Module

Item	Symbol	Min	Max	Unit
Logic/LCD Drive Voltage	VDD	-0.3	+3.6	[Volt]
Converter Input Voltage	VCC	-0.3	+14	[Volt]
Converter Control Signal	ON/OFF	-0.3	+6	[Volt]
Converter Control Signal	Dimming	-0.3	+6	[Volt]

### 4.2 Absolute Ratings of Environment

Item	Symbol	Min	Max	Unit
Operating Temperature	TOP	-30	+85	[°C]
Operation Humidity	HOP	5	90	[%RH]
Storage Temperature	TST	-30	+85	[°C]
Storage Humidity	HST	5	90	[%RH]

Note: Maximum Wet-Bulb should be 39°C and no condensation.

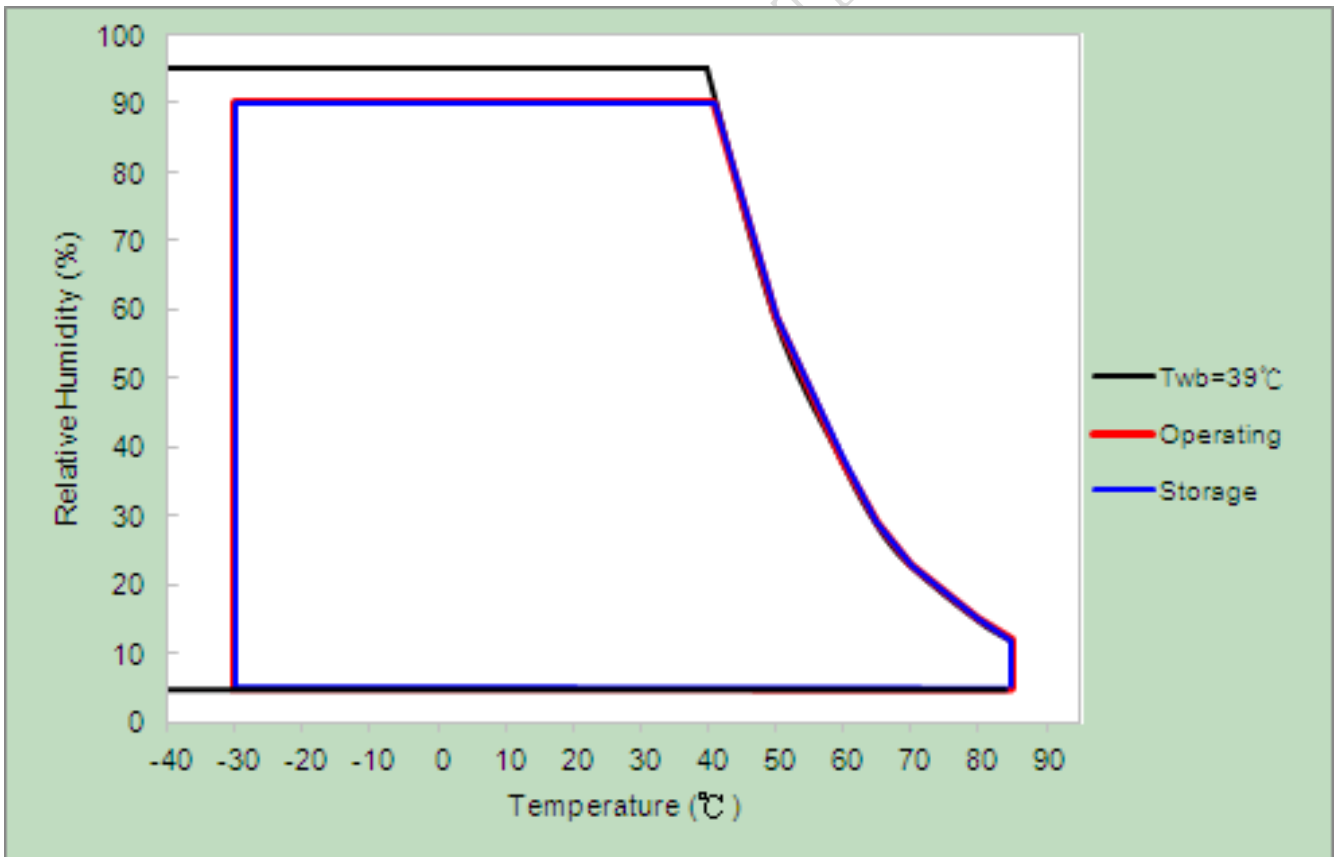

## 5. Electrical Characteristics

### 5.1 TFT LCD Module

#### 5.1.1 Power Specification

Symbol	Parameter	Min	Typ	Max	Units	Remark
<b>VDD</b>	Logic/LCD Input Voltage	3.0	3.3	3.6	[Volt]	
<b>I<sub>VDD</sub></b>	LCD Input Current	-	320	360	[mA]	VDD=3.3V at 60 HZ, all Black Pattern
<b>P<sub>VDD</sub></b>	LCD Power consumption	-	1056	1296	[mWatt]	VDD=3.3V at 60 HZ, all Black Pattern
<b>I<sub>rush LCD</sub></b>	LCD Inrush Current	-	-	1.5	[A]	Note 1; VDD=3.3V Black Pattern, Rising time=470us
<b>VDD<sub>rp</sub></b>	Allowable Logic/LCD Drive Ripple Voltage	-	-	100	[mV] p-p	VDD=3.3V at 60 HZ, all Black Pattern

Note 1: Measurement condition:

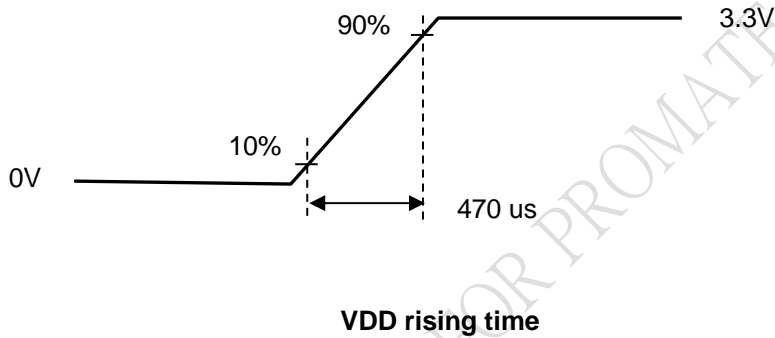

## 5.1.2 Signal Electrical Characteristics

Symbol	Item	Min.	Typ.	Max.	Unit	Remark
VTH	Differential Input High Threshold	-	-	100	[mV]	VCM=1.2V
VTL	Differential Input Low Threshold	100	-	-	[mV]	VCM=1.2V
VID	Input Differential Voltage	100	400	600	[mV]	
VCM	Differential Input Common Mode Voltage	1.15	1.2	1.45	[V]	VTH/VTL=+-100mV

Input signals shall be low or Hi-Z state when VDD is off.

Note: LVDS Signal Waveform.

### Single-end Signal

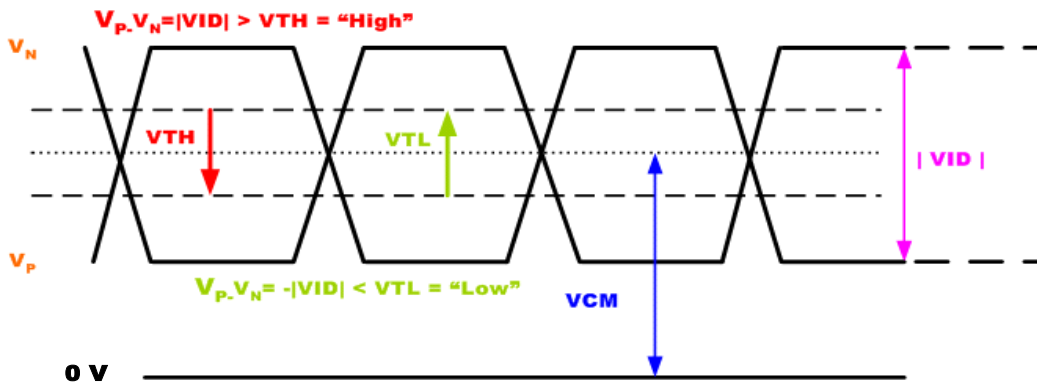

### Differential Signal

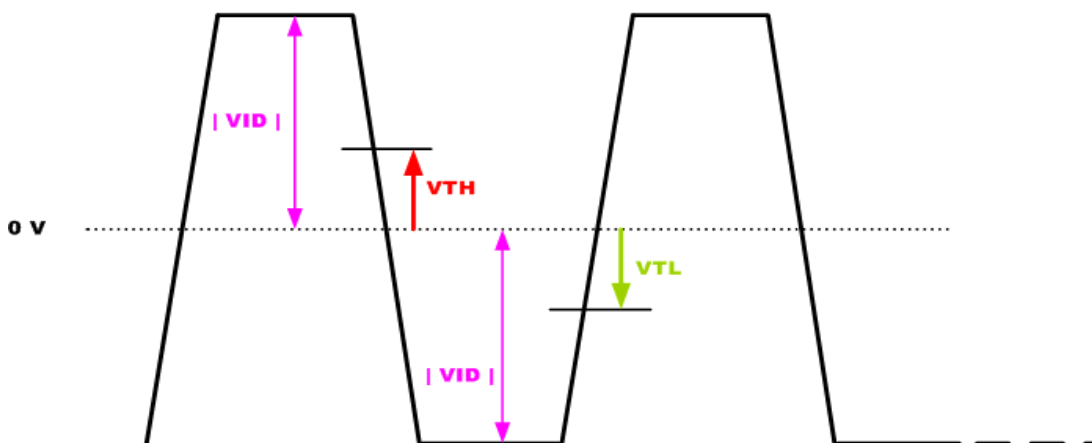

## 5.2 Backlight Unit

### 5.2.1 Parameter guideline for LCD

Following characteristics are measured under a stable condition using a inverter at 25°C. (Room Temperature):

Symbol	Parameter		Min.	Typ.	Max.	Unit	Remark
VCC	Input Voltage		10.8	12	13.2	[Volt]	
I <sub>VCC</sub>	Input Current		-	0.80	-	[A]	100% PWM Duty Ta= 25°C
P <sub>VCC</sub>	Power Consumption		-	9.23	-	[Watt]	100% PWM Duty Ta= 25°C
ON/OFF	EN Control Level	BL On	3	-	5.5	[Volt]	
		BL Off	0	-	0.5	[Volt]	
F <sub>PWM</sub>	Dimming Frequency		200	-	20K	[Hz]	PWM Control
D <sub>PWM</sub>	Dimming duty cycle		5	-	100	%	
V <sub>PWM</sub>	Dimming Control Level	High Level	3	-	5.5	[Volt]	
		Low Level	0	-	0.5	[Volt]	
I <sub>F</sub>	LED Forward Current		-	81	-	[mA]	Ta = 25°C
Operation Life			50,000	-	-	Hrs	I <sub>F</sub> = 81mA, Ta = 25°C

Note 1: Ta means ambient temperature of TFT-LCD module.

Note 2: VCC, I<sub>VCC</sub>, I<sub>rush LED</sub>, P<sub>VCC</sub> are defined for LED backlight.(100% duty of PWM dimming)

Note 3: I<sub>F</sub>, V<sub>F</sub> are defined for one channel LED. There are four LED channel in back light unit.

Note 4: If G121XTN02.0 module is driven by high current or at high ambient temperature & humidity condition. The operating life will be reduced.

Note 5: Operating life means brightness goes down to 50% initial brightness. Minimum operating life time is estimated data.

## 6. Signal Characteristics

### 6.1 Pixel Format Image

Following figure shows the relationship between input signal and LCD pixel format.

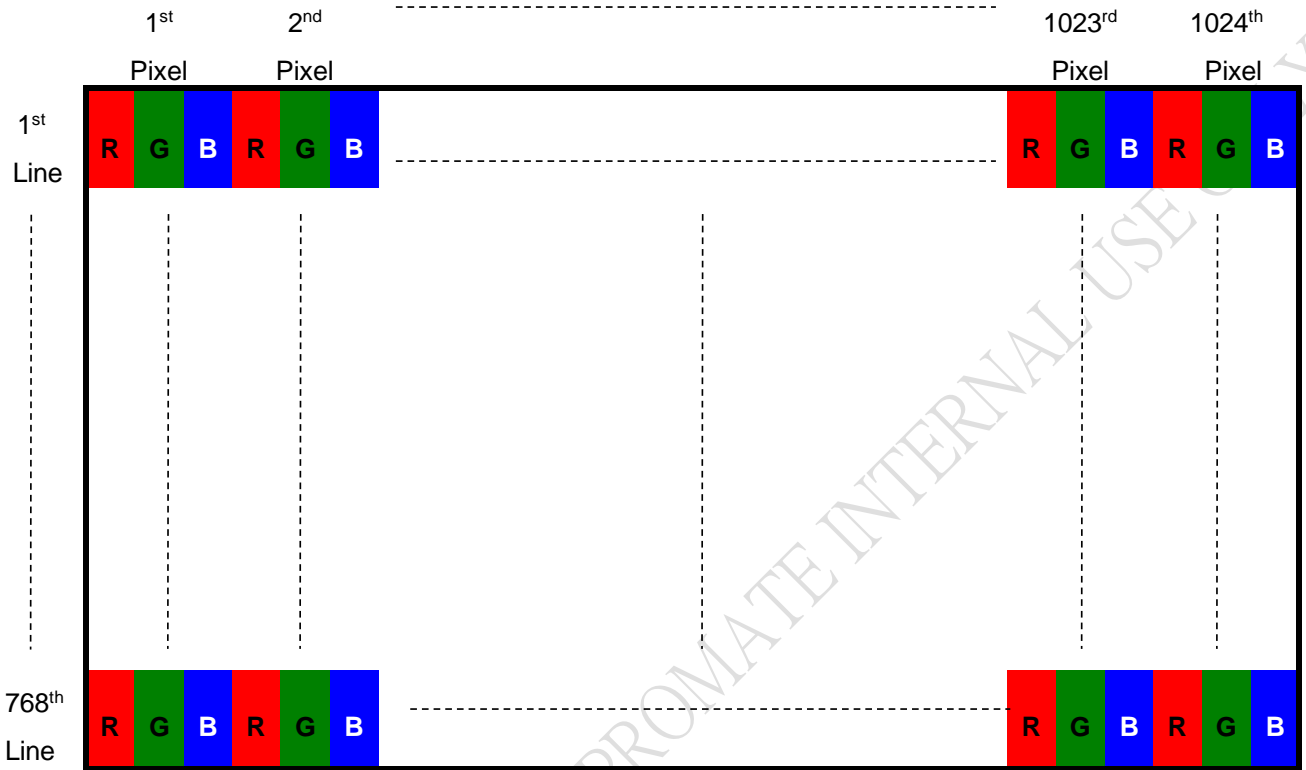

### 6.2 Scanning Direction

The following figures show the image seen from the front view. The arrow indicates the direction of scan.

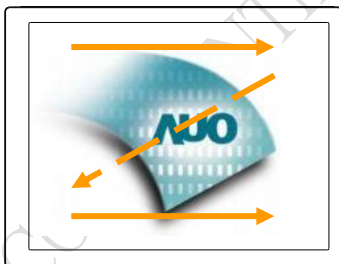

Fig. 1 Normal scan (Pin19, RVS=Low or NC)

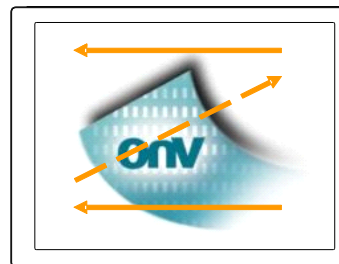

Fig. 2 Reverse scan (Pin19, RVS=High or VDD)

## 6.3 TFT-LCD Interface Signal Description

The module using a LVDS receiver embaded in AUO's ASIC. LVDS is a differential signal technology for LCD interface and a high-speed data transfer device.

Input Signal Interface		
Pin No.	Symbol	Description
1	RIN3+	LVDS receiver signal channel 3
2	RIN3-	LVDS Differential Data Input (R6, R7, G6, G7, B6, B7, RSV) Pin1 & pin 2=GND for 6bit LVDS Input
3	NC	For LCD internal use only, Do not connect
4	SEL68	6/8bits LVDS data input selection [H: 8bits L/NC: 6bit]
5	GND	Ground
6	CLKIN+	LVDS receiver signal clock
7	CLKIN-	
8	GND	Ground
9	RIN2+	LVDS receiver signal channel 2
10	RIN2-	LVDS Differential Data Input (B2, B3, B4, B5, HS, VS, DE)
11	GND	Ground
12	RIN1+	LVDS receiver signal channel 1
13	RIN1-	LVDS Differential Data Input (G1, G2, G3, G4, G5, B0, B1)
14	GND	Ground
15	RIN0+	LVDS receiver signal channel 0
16	RIN0-	LVDS Differential Data Input (R0, R1, R2, R3, R4, R5, G0)
17	SHLR	Reverse Horizontal Scan [H: Enable; L/NC: Disable]
18	UPDN	Reverse Vertical Scan [H: Enable; L/NC: Disable]
19	VDD	Power Supply, 3.3V (typical)
20	VDD	Power Supply, 3.3V (typical)

Note 1: Input Signals shall be in low status when VDD is off.

Note 2: High stands for "3.3V", Low stands for "0V", NC stands for "No Connection".

## 6.4 The Input Data Format

### 6.4.1 SEL68

SEL68 = “Low” or “NC” for 6 bits LVDS Input

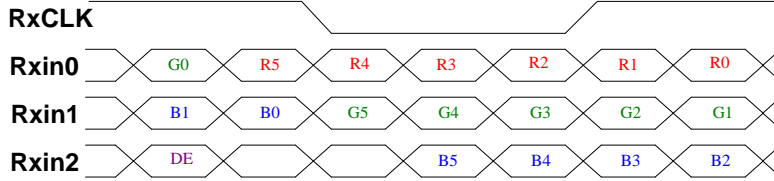

SEL68 = “High” for 8 bits LVDS Input

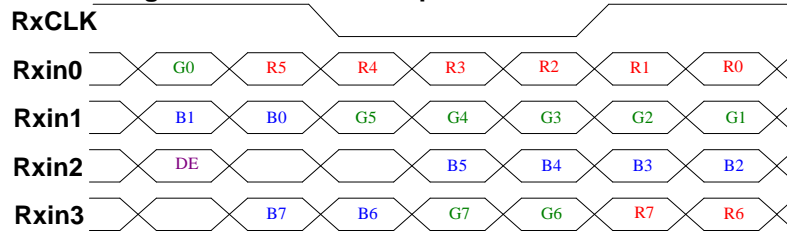

**Note1:** Please follow PSWG.

**Note2:** R/G/B data 7:MSB, R/G/B data 0:LSB

Signal Name	Description	
+RED5(R5) +RED4(R4) +RED3(R3) +RED2(R2) +RED1(R1) +RED0(R0)	Red Data 5 (MSB) Red Data 4 Red Data 3 Red Data 2 Red Data 1 Red Data 0 (LSB) Red-pixel Data	Red-pixel Data Each red pixel's brightness data consists of these 6 bits pixel data.
+GREEN5(G5) +GREEN4(G4) +GREEN3(G3) +GREEN2(G2) +GREEN1(G1) +GREEN0(G0)	Green Data 5 (MSB) Green Data 4 Green Data 3 Green Data 2 Green Data 1 Green Data 0 (LSB) Green-pixel Data	Green-pixel Data Each green pixel's brightness data consists of these 6 bits pixel data.
+BLUE5(B5) +BLUE4(B4) +BLUE3(B3) +BLUE2(B2) +BLUE1(B1) +BLUE0(B0)	Blue Data 5 (MSB) Blue Data 4 Blue Data 3 Blue Data 2 Blue Data 1 Blue Data 0 (LSB) Blue-pixel Data	Blue-pixel Data Each blue pixel's brightness data consists of these 6 bits pixel data.
CLK	Data Clock	The typical frequency is 65MHz. The signal is used to strobe the pixel data and DE signals. All pixel data shall be valid at the falling edge when the DE signal is high.
DE	Display Timing	This signal is strobed at the falling edge of CLK. When the signal is high, the pixel data shall be valid to be displayed.

Note: Output signals from any system shall be low or Hi-Z state when VDD is off.

## 6.5 TFT-LCD Interface Timing

### 6.5.1 Timing Characteristics

Signal	Symbol	Min.	Typ.	Max.	Unit	
Clock Frequency	$1/T_{Clock}$	52	65	71	MHz	
Vertical Section	Period	$T_V$	778	806	845	$T_{Line}$
	Active	$T_{VD}$	-	768	-	
	Blanking	$T_{VB}$	10	38	77	
Horizontal Section	Period	$T_H$	1114	1344	1400	$T_{Clock}$
	Active	$T_{HD}$	-	1024	-	
	Blanking	$T_{HB}$	90	320	376	

Note 1: Frame rate is 60 Hz.

Note 2: DE mode.

### 6.5.2 Input Timing Diagram

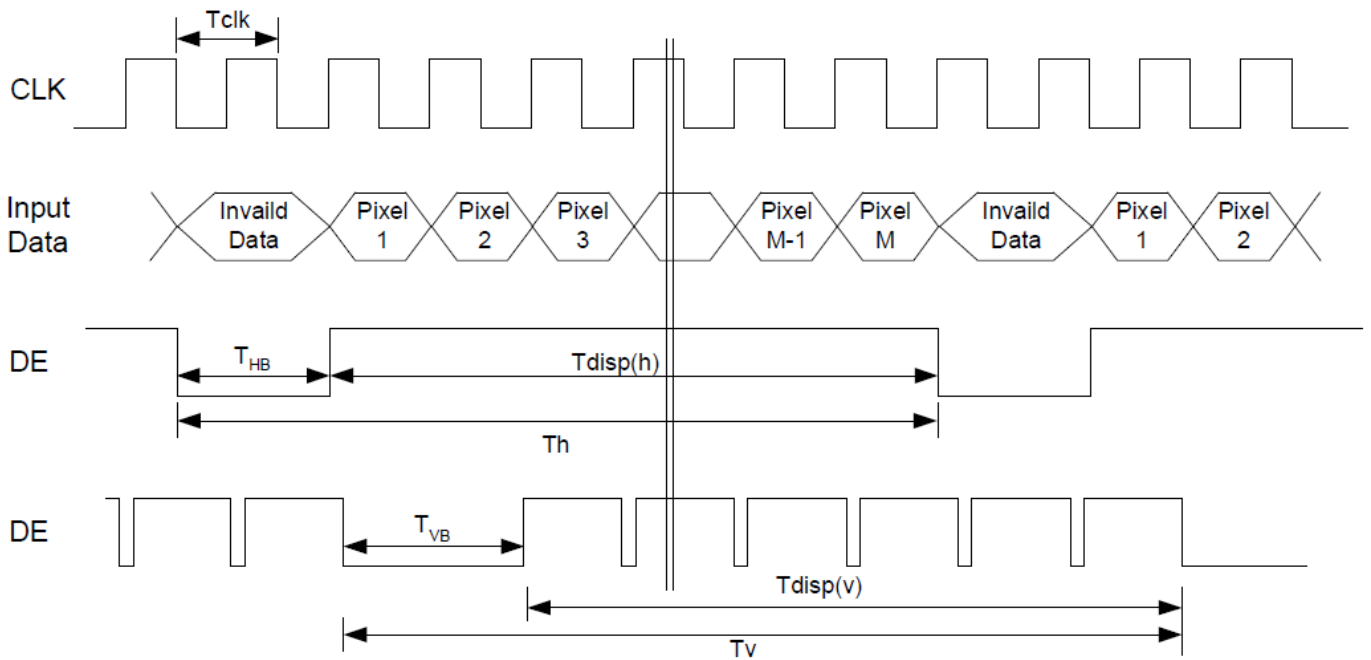

## 6.6 Power ON/OFF Sequence

VDD power and lamp on/off sequence is as below. Interface signals are also shown in the chart. Signals from any system shall be Hi-Z state or low level when VDD is off.

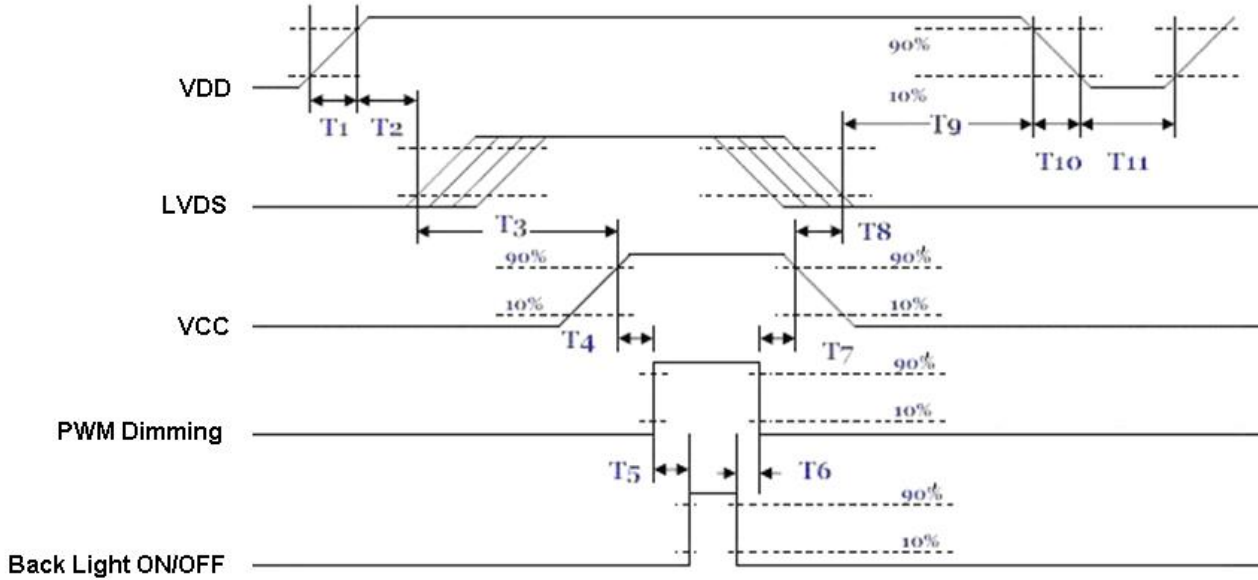

Power ON/OFF sequence timing

Parameter	Value			Units
	Min.	Typ.	Max.	
T1	0.5	-	10	[ms]
T2	30	40	50	[ms]
T3	200	-	-	[ms]
T4	10	-	-	[ms]
T5	10	-	-	[ms]
T6	0	-	-	[ms]
T7	10	-	-	[ms]
T8	100	-	-	[ms]
T9	0	16	50	[ms]
T10	-	-	10	[ms]
T11	1000	-	-	[ms]

The above on/off sequence should be applied to avoid abnormal function in the display. Please make sure to turn off the power when you plug the cable into the input connector or pull the cable out of the connector.

## 7. Connector & Pin Assignment

Physical interface is described as for the connector on module. These connectors are capable of accommodating the following signals and will be following components.

### 7.1 TFT-LCD Signal (CN1): LCD Connector

Connector Name / Designation	Signal Connector
Manufacturer	JAE or compatible
Connector Model Number	FI-SEB20P-HFE or compatible
Adaptable Plug	FI-S20S , FI-SE20ME or compatible

Pin No.	Symbol	Pin No.	Symbol
1	RIN3+	2	RIN3-
3	NC	4	SEL68
5	GND	6	CLKIN+
7	CLKIN-	8	GND
9	RIN2+	10	RIN2-
11	GND	12	RIN1+
13	RIN1-	14	GND
15	RIN0+	16	RIN0-
17	SHLR-	18	UPDN
19	VDD	20	VDD

### 7.2 LED Backlight Unit (CN2): Driver Connector

Connector Name / Designation	Lamp Connector
Manufacturer	ACES or compatible
Connector Model Number	50214-01001-001 or compatible
Mating Model Number	50216-01011-001 or compatible

Pin No.	symbol	description
Pin1	VCC	12V input
Pin2	VCC	12V input
Pin3	VCC	12V input
Pin4	VCC	12V input
Pin5	GND	GND
Pin6	GND	GND
Pin7	GND	GND
Pin8	GND	GND
Pin9	ON/OFF	5V/3.3V-ON,0V-OFF
Pin10	PWM	Dimming

## 8. Reliability Test Criteria

Items	Required Condition	Note
Temperature Humidity Bias	40 °C, 90%RH, 300 hours	
High Temperature Operation	85 °C, 300 hours	
Low Temperature Operation	-30 °C, 300 hours	
Hot Storage	85 °C, 300 hours	
Cold Storage	-30 °C, 300 hours	
Thermal Shock Test	-20 °C / 30 min, 60 °C / 30 min, 100cycles, 40 °C minimum ramp rate	
Hot Start Test	85 °C / 1Hr min. power on/off per 5 minutes, 5 times	
Cold Start Test	-30 °C / 1Hr min. power on/off per 5 minutes, 5 times	
Shock Test (Non-Operating)	50G, 20ms, Half-sine wave, ( ±X, ±Y, ±Z)	
Vibration Test (Non-Operating)	1.5G, (10~200Hz, Sine wave) 30 mins/axis, 3 direction (X, Y, Z)	
On/off test	On/10 sec, Off/10 sec, 30,000 cycles	
ESD	Contact Discharge: ± 8KV, 150pF(330Ω ) 1sec, 8 points, 25 times/ point Air Discharge: ± 15KV, 150pF(330Ω ) 1sec, 8 points, 25 times/ point	Note 1
EMI	30-230 MHz, limit 30 dBu V/m, 230-1000 MHz, limit 37 dBu V/m	

Note1: According to EN61000-4-2, ESD class B: Some performance degradation allowed. No data lost  
Self-recoverable. No hardware failures.

Note2:

- Water condensation is not allowed for each test items.
- Each test is done by new TFT-LCD module. Don't use the same TFT-LCD module repeatedly for reliability test.
- The reliability test is performed only to examine the TFT-LCD module capability.
- To inspect TFT-LCD module after reliability test, please store it at room temperature and room humidity for 24 hours at least in advance.

## 9. Mechanical Characteristics

### 9.1 LCM Outline Dimension (Front View)

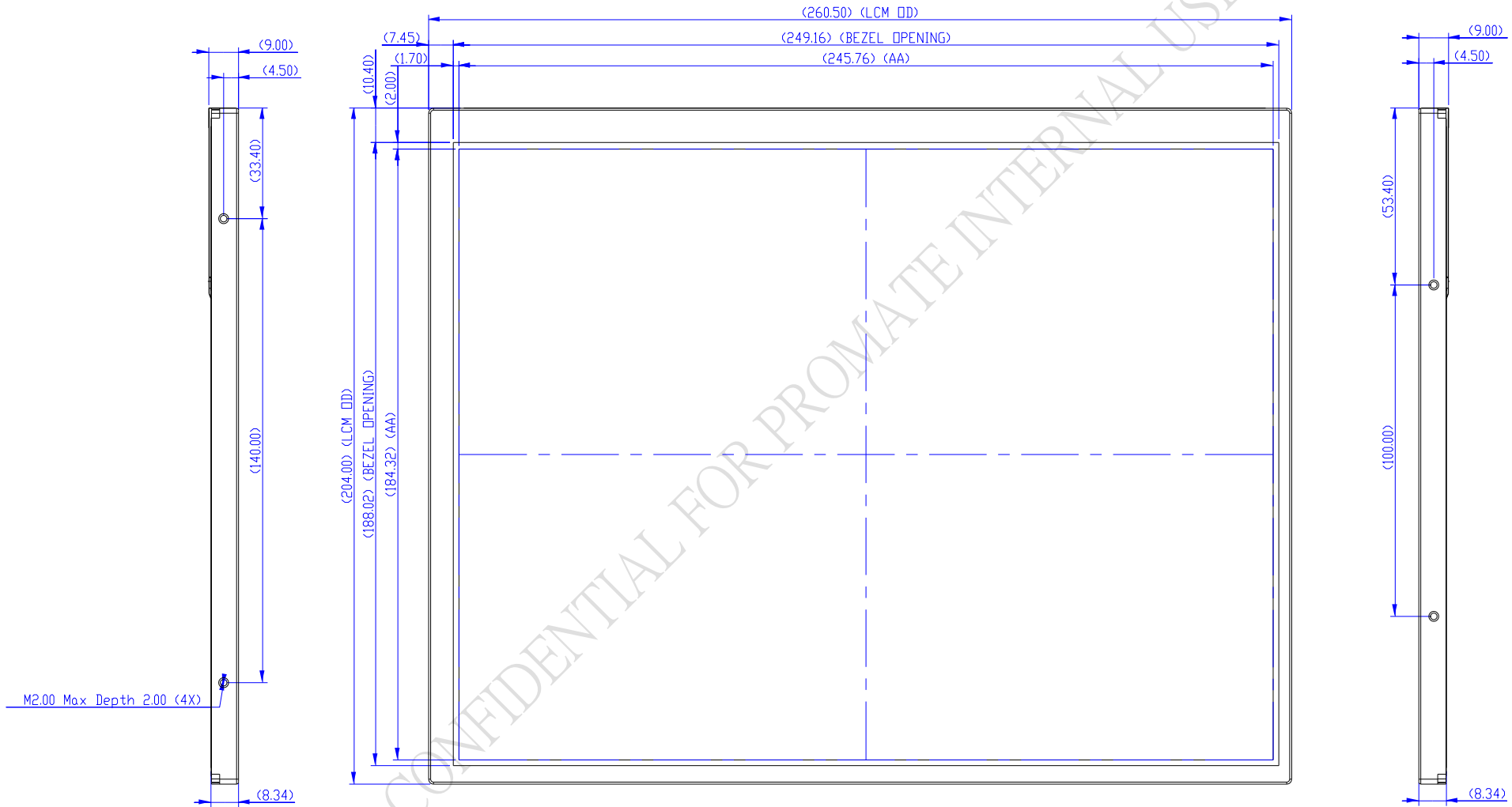

## 9.2 LCM Outline Dimension (Rear View)

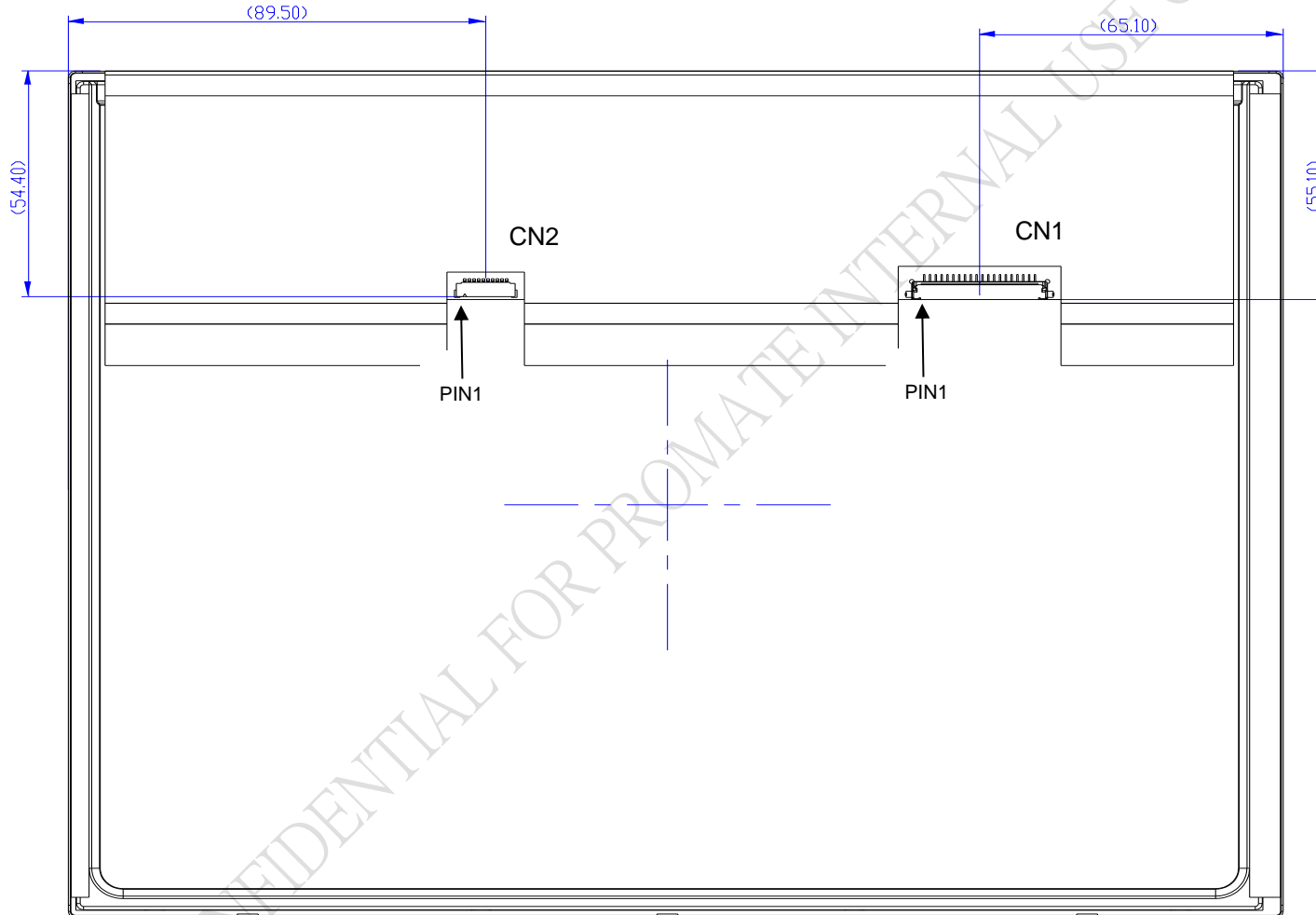

ADP CONFIDENTIAL FOR PROMATE INTERNAL USE ONLY

AUO Display+

## 10. Label and Packaging

### 10.1 Shipping Label (on the rear side of TFT-LCD display)



### 10.2 Carton Package

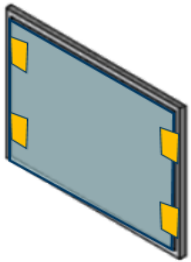

Protective film cover Panel with tape



Panel input into ESD bag

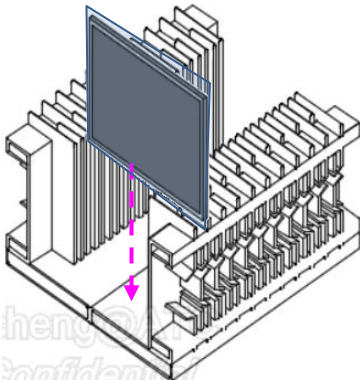
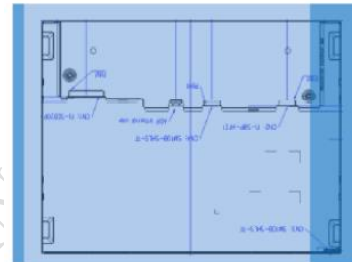

20 pcs Panel input into paper cushion

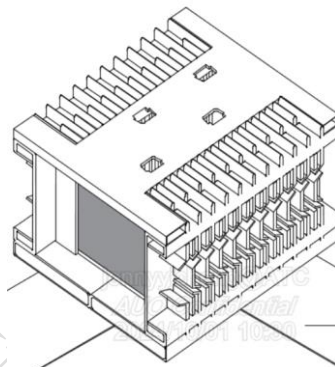

Cover the top Cushion



Closed carton by tape

20 TFT-LCD module per carton

Carton size: 570 (L)\* 320 (W)\* 420 (H)mm

Max. Weight: 12.8 kg / per carton

Packing of Pallet

Pallet size : 1150 mm\* 980 mm\* 130mm

One Pallet : (3\*2)\*3 Layers total 18 boxes/pallet(360 pcs/pallet)

Packing size (including pallet): 1150 mm\* 980mm \*1400mm

## 11 Safety

### 11.1 Keen Edge Requirements

There will be no sharp edges or comers on the display assembly that could cause injury.

### 11.2 Materials

#### 11.2.1 Toxicity

There will be no carcinogenic materials used anywhere in the display module. If toxic materials are used, they will be reviewed and approved by the responsible AUO toxicologist.

#### 11.2.2 Flammability

The printed circuit board will be made from material rated 94-V1 or better. The actual UL flammability rating will be printed on the printed circuit board.

### 11.3 Capacitors

If any polarized capacitors are used in the display assembly, provisions will be made to keep them from being inserted backwards.

### 11.4 International Safty Standard Compliance

The display module will satisfy all requirements for compliance to IEC/UL 62368-1