

- Tentative Specification
- Preliminary Specification
- Approval Specification

MODEL NO.: S320HJJ

SUFFIX: T03

Revision : B3	
Customer :	
APPROVED BY	SIGNATURE
Name / Title _____	
Note	

Please return 1 copy for your confirmation with your signature and comments.	

Approved By	Checked By	Prepared By
Chris Chen	SJ Chien	Chiawen Chen

CONTENTS

CONTENTS.....	2
1. GENERAL DESCRIPTION	5
1.1 OVERVIEW.....	5
1.2 FEATURES.....	5
1.3 GENERAL SPECIFICATIONS	5
1.4 MECHANICAL SPECIFICATIONS	6
2. ABSOLUTE MAXIMUM RATINGS	7
2.1 ABSOLUTE RATINGS OF ENVIRONMENT	7
2.2 PACKAGE STORAGE.....	7
2.3 ELECTRICAL ABSOLUTE RATINGS	8
2.3.1 TFT LCD MODULE	8
2.3.2 BACKLIGHT CONVERTER UNIT	8
3. ELECTRICAL CHARACTERISTICS.....	9
3.1 TFT LCD MODULE	9
3.2 BACKLIGHT CONVERTER UNIT.....	11
3.2.1 CONVERTER CHARACTERISTICS (Ta=25±2°C)	11
3.2.2 CONVERTER INTERFACE CHARACTERISTICS	13
4. INTERFACE PIN CONNECTION	15
4.1 TFT LCD MODULE	15
4.2 BACKLIGHT UNIT	18
4.2.1 LIGHT BAR UNIT.....	18
4.2.2 CONVERTER UNIT	20
4.3 LVDS INTERFACE	22
4.4 COLOR DATA INPUT ASSIGNMENT	23
5. INTERFACE TIMING.....	24
5.1 INPUT SIGNAL TIMING SPECIFICATIONS	24
5.2 POWER ON/OFF SEQUENCE.....	27
6. OPTICAL CHARACTERISTICS.....	28
6.1 TEST CONDITIONS.....	28
6.2 OPTICAL SPECIFICATIONS.....	29
7. PRECAUTIONS.....	32
7.1 SAFETY PRECAUTIONS.....	32
7.2 PRECAUTIONS FOR STRONG LIGHT EXPOSURE.....	32

7.3 SAFETY STANDARDS..... 33

8. DEFINITION OF LABELS..... 34

 8.1 MODULE LABEL..... 34

 8.2 CARTON LABEL 35

9. PACKAGING 36

 9.1 PACKAGING SPECIFICATIONS 36

 9.2 PACKAGING METHOD 36

 9.3 UN-PACKAGING METHOD 37

10. MECHANICAL CHARACTERISTIC 38

REVISION HISTORY

Version	Date	Page(New)	Section	Description
Ver. 1.1	2024. 12. 4	ALL	ALL	Preliminary Specification first issued.

1. GENERAL DESCRIPTION

1.1 OVERVIEW

S320HJJ-T03 is a 32" TFT Liquid Crystal Display PID module with LED Backlight unit and 2ch-LVDS interface. This module supports 1920 x 1080 Full HDTV format and can display 16.7M colors (8-bit). The driving board module for backlight is built-in.

1. Liquid crystal: High Tni LC (110°C)
2. Polarizer: Wide temperature polarizer (95°C)

1.2 FEATURES

- High brightness 2000 nits
- High contrast ratio 5000:1
- Fast response time Gray to gray average 11 ms
- High color saturation NTSC 72%
- Full HDTV (1920 x 1080 pixels) resolution, true HDTV format
- DE (Data Enable) only mode
- LVDS (Low Voltage Differential Signaling) interface
- Optimized response time for 50Hz/60Hz frame rate
- Ultra wide viewing angle : Super MVA technology
- Viewing Angle : 178(H)/178(V) (CR ≥ 10) VA Technology
- RoHs compliance
- T-con input frame rate: 50Hz/60Hz, output frame rate: 50Hz/60Hz

1.3 GENERAL SPECIFICATIONS

Item	Specification	Unit	Note
Active Area	698.40(H) x 392.85 (V) (32" diagonal)	mm	(1)
Bezel Opening Area	702.40(H) x 396.85(V)	mm	
Driver Element	a-si TFT active matrix	-	-
Pixel Number	1920 x R.G.B. x 1080	pixel	-
Pixel Pitch	0.36375(H) x 0.36375(V)	mm	-
Pixel Arrangement	RGB vertical stripe	-	-
Display Colors	16.7M colors (8-bit)	color	-
Display Operation Mode	Transmissive mode / Normally black	-	-
Surface Treatment	AG, Haze (~28%) Hardness : 3H	-	(2)
Rotation Function	Unachievable		(3)
Display Orientation	Signal input with "INX"		(3)

Note (1) Please refer to the attached drawings in chapter 9 for more information about the front and back outlines.

Note (2) The spec. of the surface treatment is temporarily for this phase. INX reserves the rights to change this feature.

Note (3)

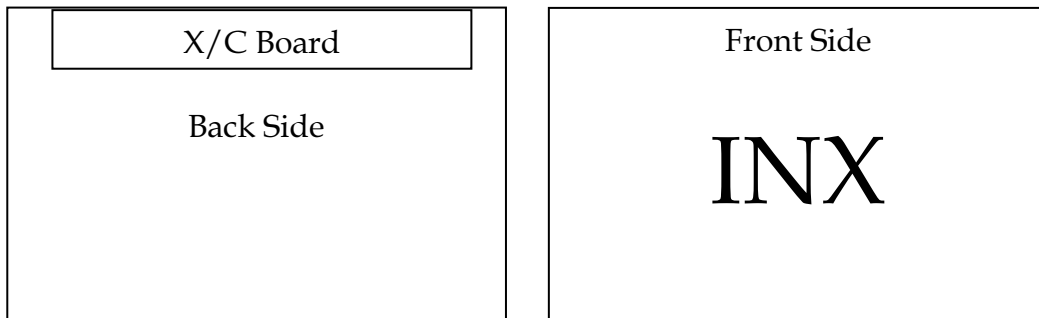

1.4 MECHANICAL SPECIFICATIONS

Item		Min.	Typ.	Max.	Unit	Note
Module Size	Horizontal (H)	722.6	723.6	724.6	mm	(1)
	Vertical (V)	417	418	419	mm	(1)
	Thickness (T)	37	38	39	mm	(2)
	Thickness (T)		(38)		mm	(3)
Weight			(4680)		g	

Note (1) Please refer to the attached drawings for more information of front and back outline dimensions.

Note (2) Module Depth is between bezel to T-CON cover.

Note (3) Module Depth is between bezel to Converter cover

2. ABSOLUTE MAXIMUM RATINGS

2.1 ABSOLUTE RATINGS OF ENVIRONMENT

Item	Symbol	Value		Unit	Note
		Min.	Max.		
Storage Temperature	T _{ST}	-30	+70	°C	(1), (3), (4)
Operating Ambient Temperature	T _{OP}	-30	+70	°C	(1), (3), (4)
Panel Surface Temperature	T _{PS}	-	+80	°C	(2)

Note (1) Temperature and relative humidity range is shown in the figure below.

- (a) 90 %RH Max. ($T_a \leq 40 \text{ }^\circ\text{C}$)
- (b) Wet-bulb temperature should be 39 °C Max.
- (c) No condensation.

Note (2) Surface temperature is measured at 70 °C dry condition.

Note (3) The specified temperature range is determined by the design of the product module. When integrated with the customer’s system, it is imperative to control environmental conditions within this prescribed range; otherwise, the operational capability of the product cannot be guaranteed.

Note (4) Low temperature start can only be performed when the ambient temperature is greater than -20°C.

Response time depends on the temperature. (In lower temperature, it becomes longer.)

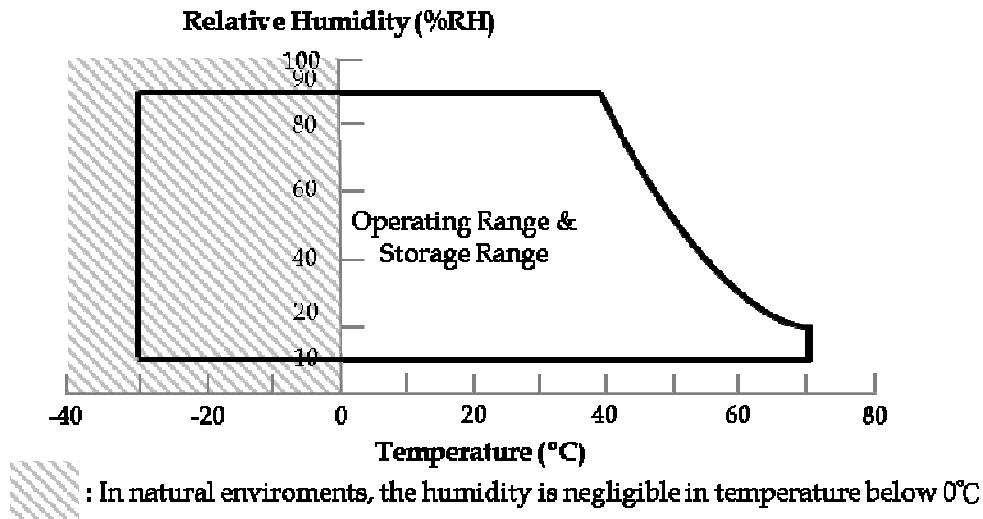

2.2 PACKAGE STORAGE

When storing modules as spares for a long time, the following precaution is necessary.

- (a) Do not leave the module in high temperature, and high humidity for a long time, It is highly recommended to store the module with temperature from 0 to 35 °C at normal humidity without condensation.
- (b) The module shall be stored in dark place. Do not store the TFT-LCD module in direct sunlight or fluorescent light.

2.3 ELECTRICAL ABSOLUTE RATINGS

2.3.1 TFT LCD MODULE

Item	Symbol	Value		Unit	Note
		Min.	Max.		
Power Supply Voltage	VCC	-0.3	13.5	V	(1)
Logic Input Voltage	VIN	-0.3	3.6	V	

Note (1) Permanent damage to the device may occur if maximum values are exceeded. Function operation should be restricted to the conditions described under Normal Operating Conditions

2.3.2 BACKLIGHT CONVERTER UNIT

Item	Symbol	Value		Unit	Note
		Min.	Max.		
Light Bar Voltage	VW	—	44	VRMS	
Converter Input Voltage	VBL	21.6	26.4	V	(1)
Control Signal Level	—	-0.3	6	V	(1), (3)

Note (1) Permanent damage to the device may occur if maximum values are exceeded. Functional operation should be restricted to the conditions described under normal operating conditions.

Note (2) No moisture condensation or freezing.

Note (3) The control signals include On/Off Control and External PWM Control.

3. ELECTRICAL CHARACTERISTICS

3.1 TFT LCD MODULE

(Ta = 25 ± 2 °C)

Parameter		Symbol	Value			Unit	Note
			Min.	Typ.	Max.		
Power Supply Voltage		V _{CC}	10.8	12	13.2	V	(1)
Rush Current		I _{RUSH}	—	—	1.56	A	(2)
Power Consumption	White Pattern	P _T	—	7.06	7.76	W	(3)
	Black Pattern	P _T	—	4.30	4.73	W	
	Horizontal Stripe	P _T	—	6.88	7.57	W	
Power Supply Current	White Pattern	—	—	0.60	0.73	A	
	Black Pattern	—	—	0.37	0.45	A	
	Horizontal Stripe	—	—	0.60	0.72	A	
LVDS interface	Differential Input High Threshold Voltage	V _{LVTH}	—	—	+100	mV	(4)
	Differential Input Low Threshold Voltage	V _{LVTL}	-100	—	—	mV	
	Common Input Voltage	V _{CM}	1.0	1.2	1.4	V	
	Differential input voltage (single-end)	V _{ID}	100	—	600	mV	
	Terminating Resistor	R _T	—	100	—	ohm	
CMIS interface	Input High Threshold Voltage	V _{IH}	2.7	—	3.3	V	
	Input Low Threshold Voltage	V _{IL}	0	—	0.7	V	

Note (1) The module should be always operated within the above ranges. The ripple voltage should be controlled under 10% of V_{cc} (Typ.)

Note (2) Measurement Conditions :

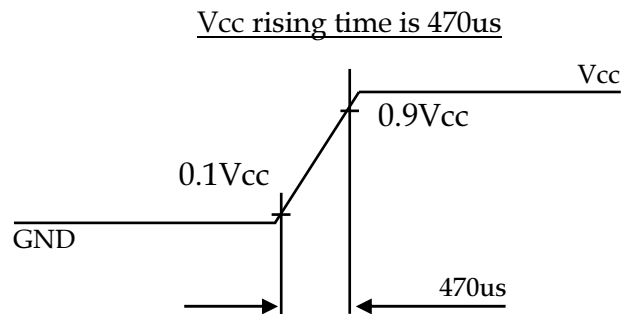
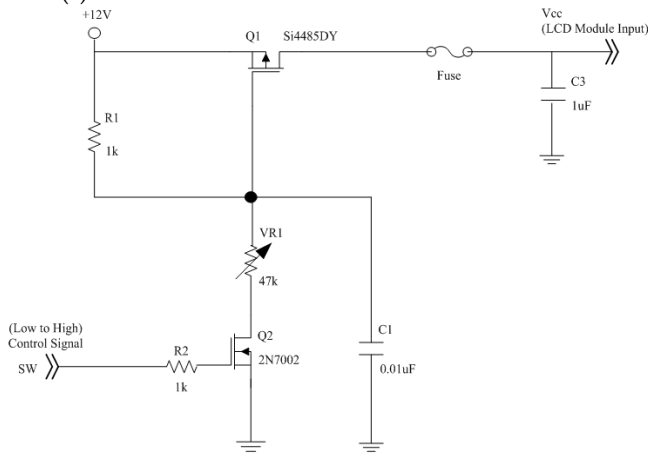

Note (3) The specified power supply current is under the conditions at $V_{cc} = 12\text{ V}$, $T_a = 25 \pm 2\text{ }^\circ\text{C}$, $f_v = 60\text{ Hz}$, whereas a power dissipation check pattern below is displayed.

a. White Pattern

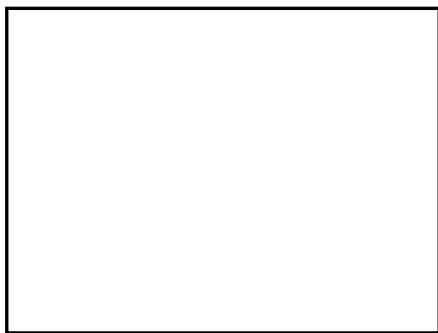

Active Area

b. Black Pattern



Active Area

c. Horizontal Pattern

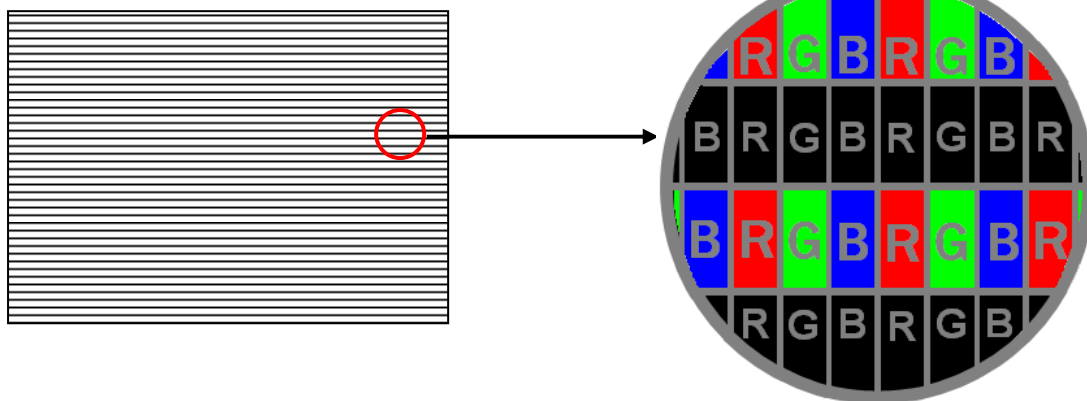

Note (4) The LVDS input characteristics is shown as below : The position of measurement is TCON LVDS input pin.
The differential voltage must be higher than V_{TH} and lower than V_{TL} to ensure that the receiver indicates a valid logic state at its output.

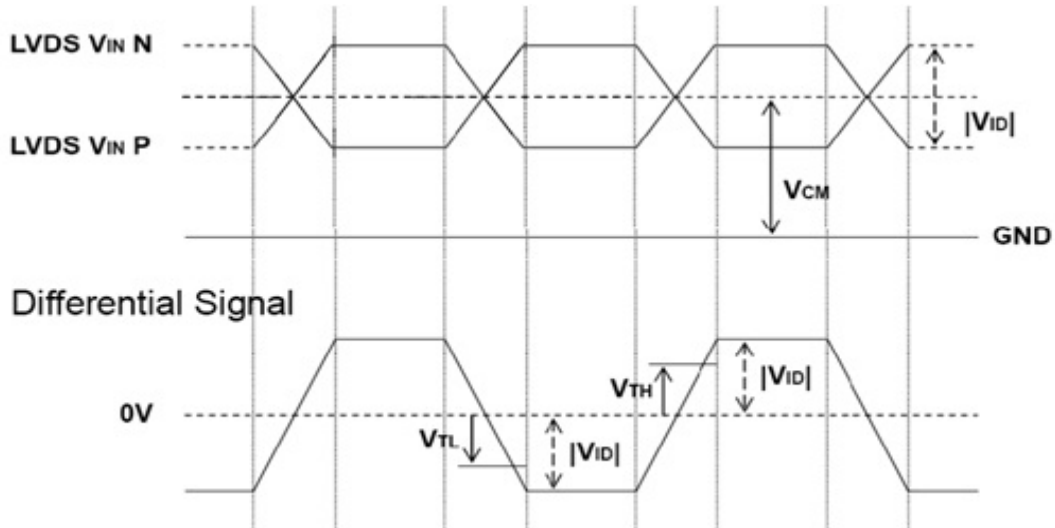

3.2 BACKLIGHT CONVERTER UNIT

3.2.1 CONVERTER CHARACTERISTICS ($T_a = 25 \pm 2^\circ\text{C}$)

Parameter	Symbol	Value			Unit	Note
		Min.	Typ.	Max.		
Power Consumption	P_{BL}	-	80.5	93.5	W	(1), (2)
Converter Input Voltage	V_{BL}	22.8	24	25.2	VDC	
Converter Input Current	I_{BL}	-	3.4	3.9	A	Non Dimming
Input Inrush Current	I_R	-	-	6.4	A _{peak}	$V_{BL}=22.8V_7$ (3), (6)
Dimming Frequency	FB	180	-	220	Hz	(5)
Dimming Duty Ratio	DDR	5	-	100	%	(4), (5)
Life Time	-	50000	-	-	Hrs	(7)

Note (1) The power supply capacity should be higher than the total converter power consumption P_{BL} . Since the pulse width modulation (PWM) mode was applied for backlight dimming, the driving current changed as PWM duty on and off. The transient response of power supply should be considered for the changing loading when converter dimming.

Note (2) The measurement condition of Max. value is based on 32" backlight unit under input voltage 24V.

Note (3) For input inrush current measure, the V_{BL} rising time from 10% to 90% is about 20ms.

Note (4) EPWM signal have to input available duty range. 5% minimum duty ratio is only valid for electrical operation.

Note (5) The lifetime is defined as the time which luminance of the LED decays to 50% compared to the initial value,
Operating condition: Continuous operating at $T_a = 25 \pm 2^\circ\text{C}$

Note (6) Below diagram is only for power supply design reference.

Test Condition : $V_{BL} = 22.8V$ at 2D Mode

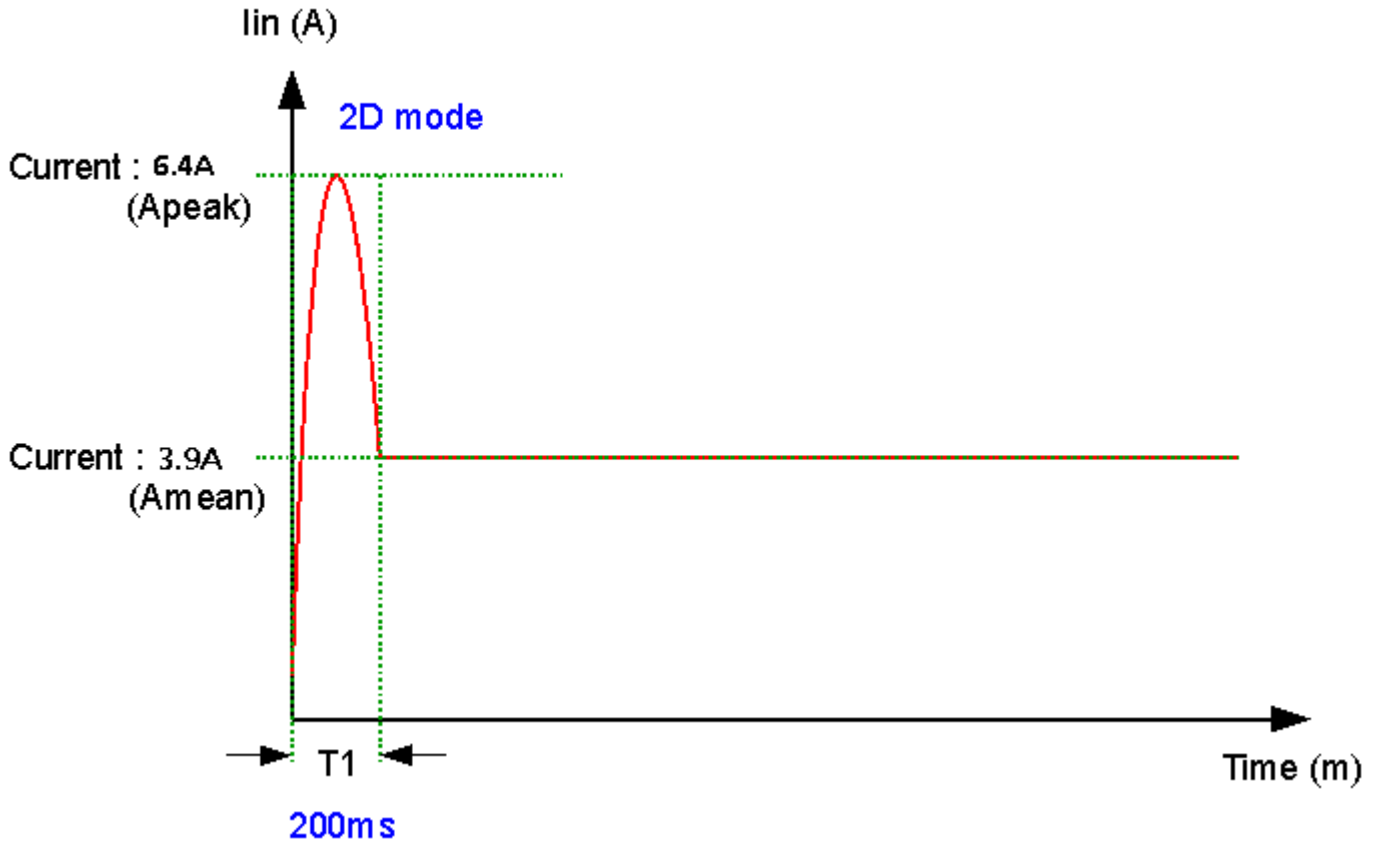

Note (7) The lifetime is defined as the time which luminance of the LED decays to 50% compared to the initial value,
Operating condition: Continuous operating at $T_a = 25 \pm 2^\circ C$

3.2.2 CONVERTER INTERFACE CHARACTERISTICS

Parameter		Symbol	Test Condition	Value			Unit	Note	
				Min.	Typ.	Max.			
On/Off Control Voltage	ON	VBLON	—	2.0	—	5.0	V		
	OFF		—	0	—	0.8	V		
External PWM Control Voltage	HI	VEPWM	—	2.0	—	5.0	V	Duty on	(5)
	LO		—	0	—	0.8	V	Duty off	
Error Signal		ERR	—	—	—	—	—	Abnormal: Open collector	
VBL Rising Time		Tr1	—	20	—	—	ms	10%-90% V _{BL}	
Control Signal Rising Time		Tr	—	—	—	100	ms		
Control Signal Falling Time		Tf	—	—	—	100	ms		
PWM Signal Rising Time		TPWMR	—	—	—	50	us		
PWM Signal Falling Time		TPWMF	—	—	—	50	us		
Input Impedance		Rin	—	1	—	—	MΩ		
PWM Delay Time		TPWM	—	100	—	—	ms		
BLON Delay Time		T _{on}	—	300	—	—	ms		
		T _{on1}	—	300	—	—	ms		
BLON Off Time		Toff	—	300	—	—	ms		

Note (1) The Dimming signal should be valid before backlight turns on by BLON signal. It is inhibited to change the external PWM signal during backlight turn on period.

Note (2) The power sequence and control signal timing are shown in the Fig.1. For a certain reason, the converter has a possibility to be damaged with wrong power sequence and control signal timing.

Note (3) While system is turned ON or OFF, the power sequences must follow as below descriptions:

Turn ON sequence: VBL → PWM signal → BLON

Turn OFF sequence: BLOFF → PWM signal → VBL

Note (4) When converter protective function is triggered, ERR will output open collector status. (Fig.2)

Note (5) The EPWM interface that inserts a pull up resistor to 5V in Max Duty (100%), please refers to Fig.3.

Note (6) EPWM signal have to input available frequency range.

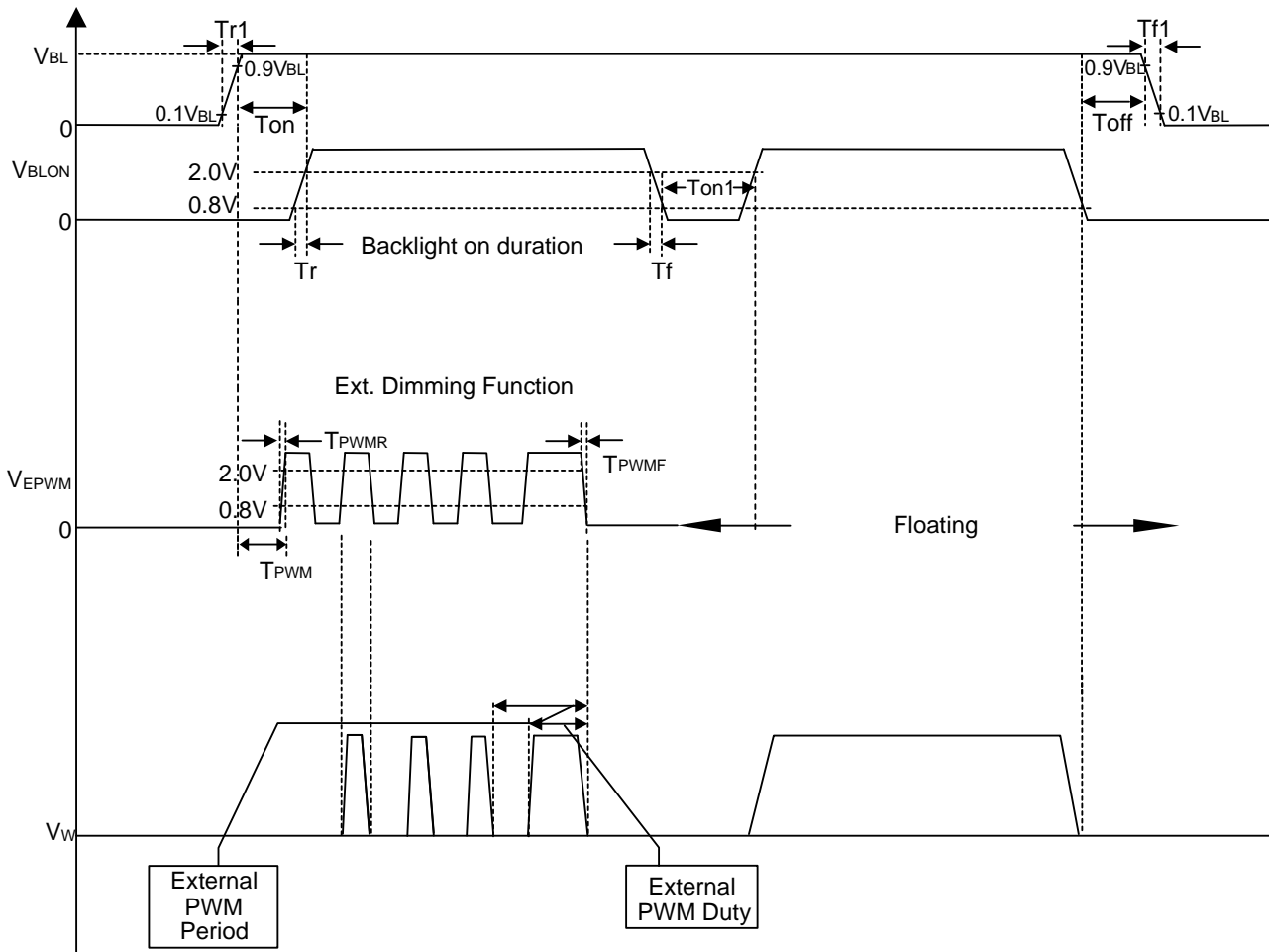

100%

Fig. 1

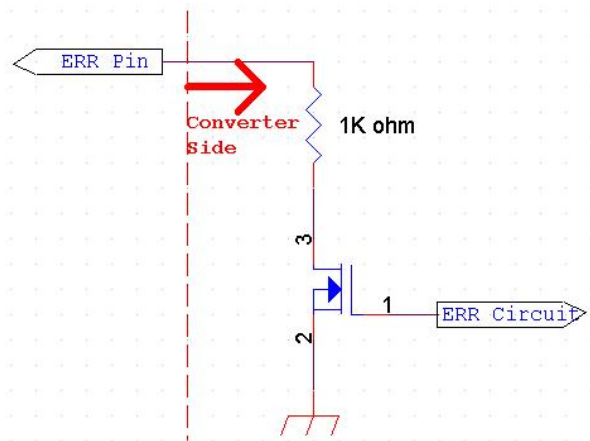

Fig. 2

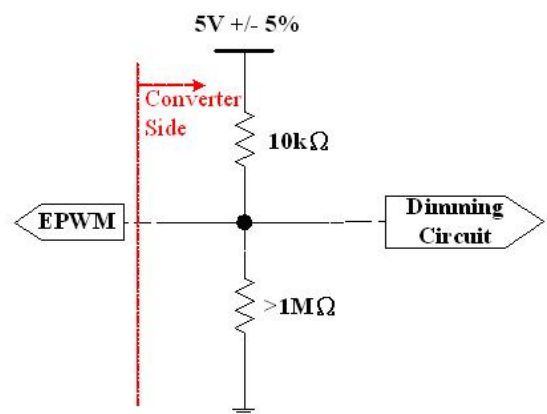

Fig. 3

4. INTERFACE PIN CONNECTION

4.1 TFT LCD MODULE

CNX11 Connector Pin Assignment: [187059-51221 (P-Two), WF23-402-5133(FCN)]

Pin	Name	Description	Note
1	NC	No connection	(2)
2	NC	No connection	
3	NC	No connection	
4	NC	No connection	
5	NC	No connection	
6	NC	No connection	
7	SELLVDS	LVDS data format Selection	(3)(4)
8	NC	No Connection	(2)
9	NC	No Connection	
10	NC	No connection	
11	GND	Ground	
12	ORX0-	Odd pixel Negative LVDS differential data input. Channel 0	(5)
13	ORX0+	Odd pixel Positive LVDS differential data input. Channel 0	
14	ORX1-	Odd pixel Negative LVDS differential data input. Channel 1	
15	ORX1+	Odd pixel Positive LVDS differential data input. Channel 1	
16	ORX2-	Odd pixel Negative LVDS differential data input. Channel 2	
17	ORX2+	Odd pixel Positive LVDS differential data input. Channel 2	
18	GND	Ground	
19	OCLK-	Odd pixel Negative LVDS differential clock input.	(5)
20	OCLK+	Odd pixel Positive LVDS differential clock input.	
21	GND	Ground	
22	ORX3-	Odd pixel Negative LVDS differential data input. Channel 3	(5)
23	ORX3+	Odd pixel Positive LVDS differential data input. Channel 3	
24	N.C.	No Connection	(2)
25	N.C.	No Connection	
26	N.C.	No Connection	
27	N.C.	No Connection	
28	ERX0-	Even pixel Negative LVDS differential data input. Channel 0	(5)
29	ERX0+	Even pixel Positive LVDS differential data input. Channel 0	
30	ERX1-	Even pixel Negative LVDS differential data input. Channel 1	
31	ERX1+	Even pixel Positive LVDS differential data input. Channel 1	
32	ERX2-	Even pixel Negative LVDS differential data input. Channel 2	
33	ERX2+	Even pixel Positive LVDS differential data input. Channel 2	
34	GND	Ground	
35	ECLK-	Even pixel Negative LVDS differential clock input	(5)
36	ECLK+	Even pixel Positive LVDS differential clock input	
37	GND	Ground	

38	ERX3-	Even pixel Negative LVDS differential data input. Channel 3	(5)
39	ERX3+	Even pixel Positive LVDS differential data input. Channel 3	
40	N.C.	No Connection	(2)
41	N.C.	No Connection	
42	N.C.	No Connection	
43	N.C.	No Connection	
44	GND	Ground	
45	GND	Ground	
46	GND	Ground	
47	N.C.	No Connection	(2)
48	VCC	Power input (+12V)	
49	VCC	Power input (+12V)	
50	VCC	Power input (+12V)	
51	VCC	Power input (+12V)	

Note (1) LVDS connector pin order is defined as below.

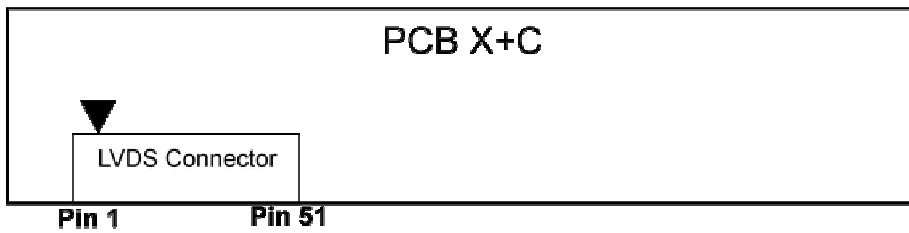

Note (2) Reserved for internal use. Please leave it open.

Note (3) Connect to Open or +3.3V: VESA Format, connect to GND: JEIDA Format.

SELLVDS	Mode
H(default)	VESA
L	JEIDA

L : Connect to GND, H : Connect to Open or +3.3V

Note (4) Interface optional pin has internal scheme as following diagram. Customer should keep the interface voltage level requirement which including panel board loading as below.

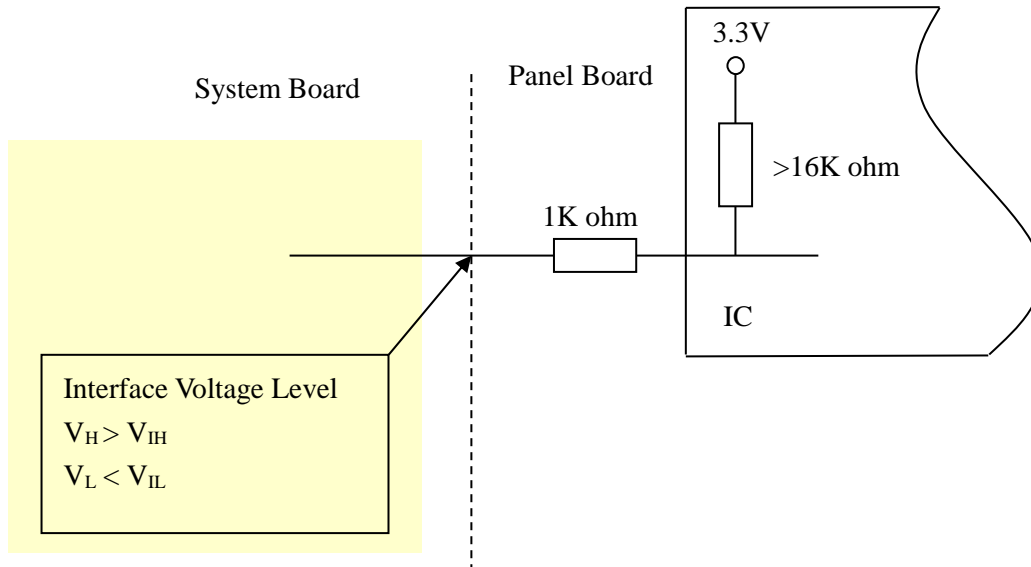

Note (5) Two pixel data send into the module for every clock cycle. The first pixel of the frame is odd pixel and the second pixel is even pixel.

Note (6) LVDS connector mating dimension range request is 0.93mm~1.0mm as below. (Lock type)
LVDS connector Recommend Mating FFC drawing as below.

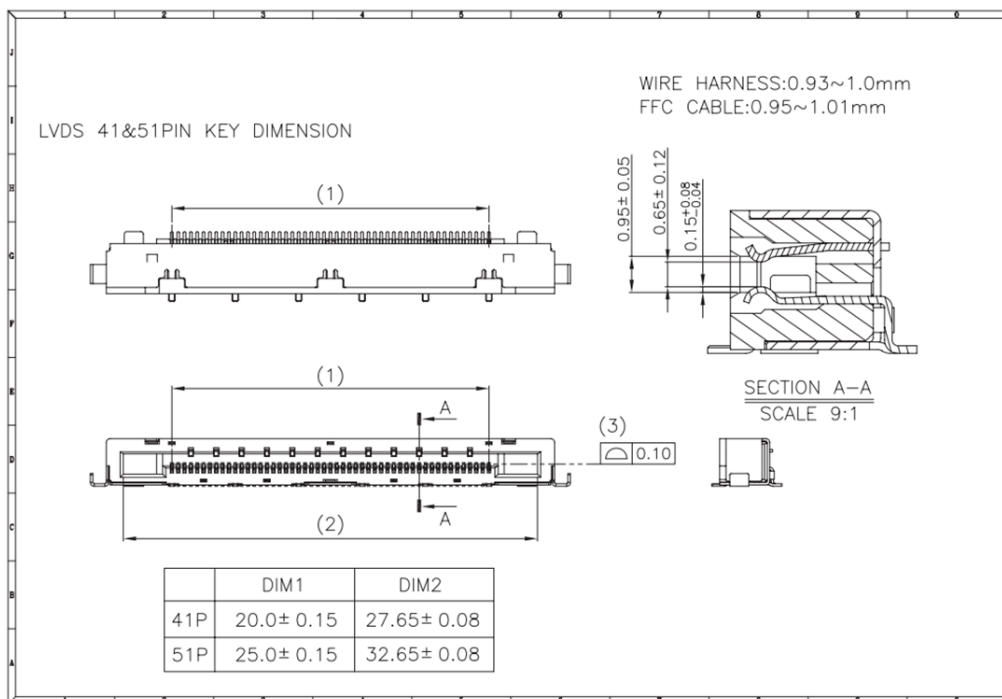

4.2 BACKLIGHT UNIT

4.2.1 LIGHT BAR UNIT

The pin configuration for the housing and lead wire is shown in the table below.

CNV03 Connector Pin Assignment: [WM13-412-163N (FCN) & CI1416M1HRM-NH (CVILUX)]

Pin No	Symbol	Feature
1	VLED+	Positive of LED String
2		
3		
4		
5		
6		
7		
8		
9	N9	Negative of LED String
10	N10	
11	N11	
12	N12	
13	N13	
14	N14	
15	N15	
16	N16	

Note (1) Light Bar Input connector pin order defined as follows

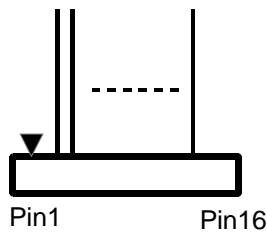

Input Connector

CNV06 Connector Pin Assignment: [WM13-412-163N (FCN) & CI1416M1HRM-NH (CVILUX)]

Pin No	Symbol	Feature
1	VLED+	Positive of LED String
2		
3		
4		
5		
6		
7		
8		
9	N1	Negative of LED String
10	N2	
11	N3	
12	N4	
13	N5	
14	N6	
15	N7	
16	N8	

Note (1) Light Bar Input connector pin order defined as follows

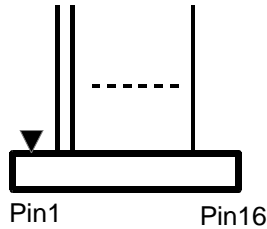

Input Connector

4.2.2 CONVERTER UNIT

CNV01 Connector Pin Assignment: [CI0114M1HR0-LA (CvilLux) , JH2-D4-143N (FCN)]

Matting connector : [JST PHR-14]

Pin No.	Symbol	Feature
1	VBL	+24V
2		
3		
4		
5		
6	GND	GND
7		
8		
9		
10		
11	ERR	Normal (GND) ; Abnormal (Open collector)
12	BLON	BL ON/OFF
13	NC	NC
14	E_PWM	External PWM Control

Note (1) The pin14 must be connected to EPWM simultaneously.

Note (2) If Pin14 is open, E_PWM is 100% duty.

Note (3) Input connector pin order defined as follows

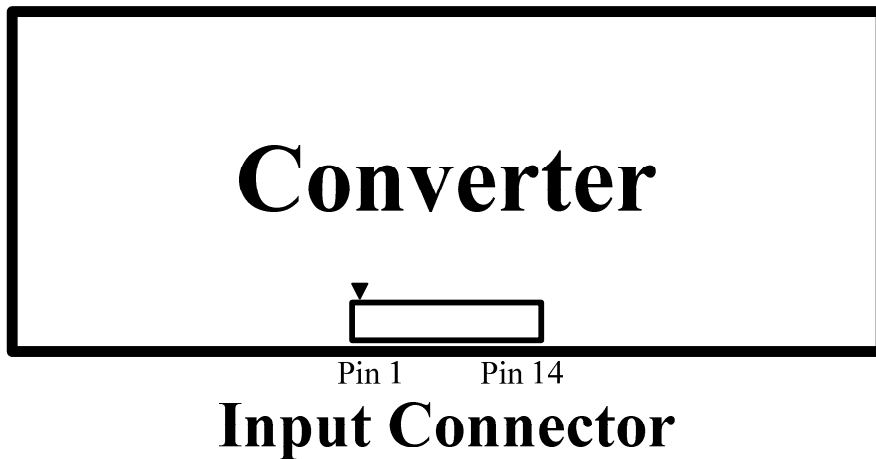

CNV02 Connector Pin Assignment: [CI0112M1HR0-LA (CvilLux) , JH2-D4-123N (FCN)]

Pin No.	Symbol	Feature
1	VBL	+24V
2		
3		
4		
5		
6	GND	GND
7		
8		
9		
10		
11	NC	NC
12	NC	NC

4.3 LVDS INTERFACE

VESA Format : SELLVDS = H or Open

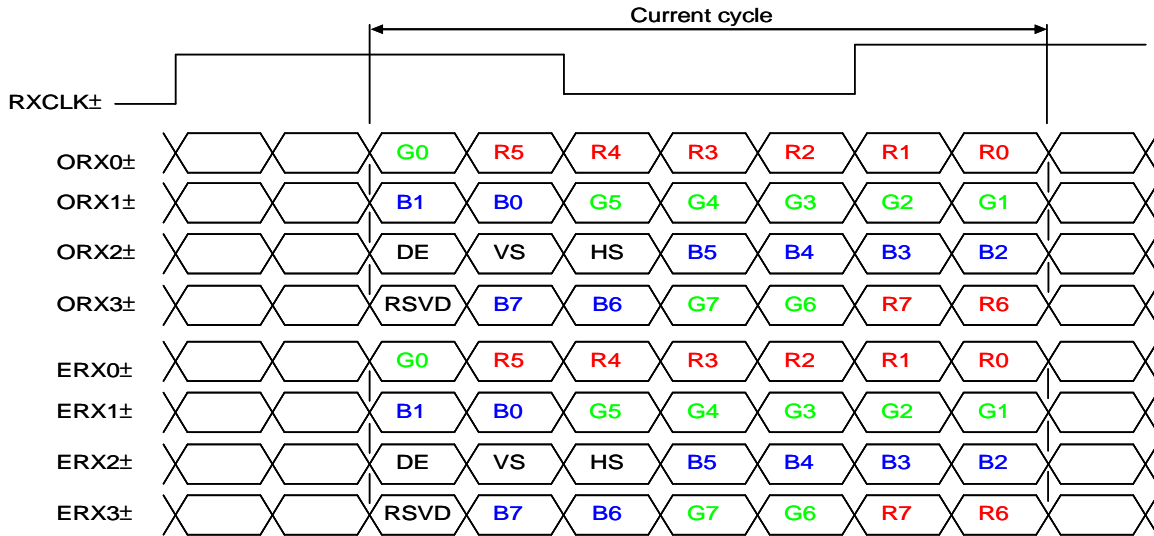

JEIDA Format : SELLVDS = L

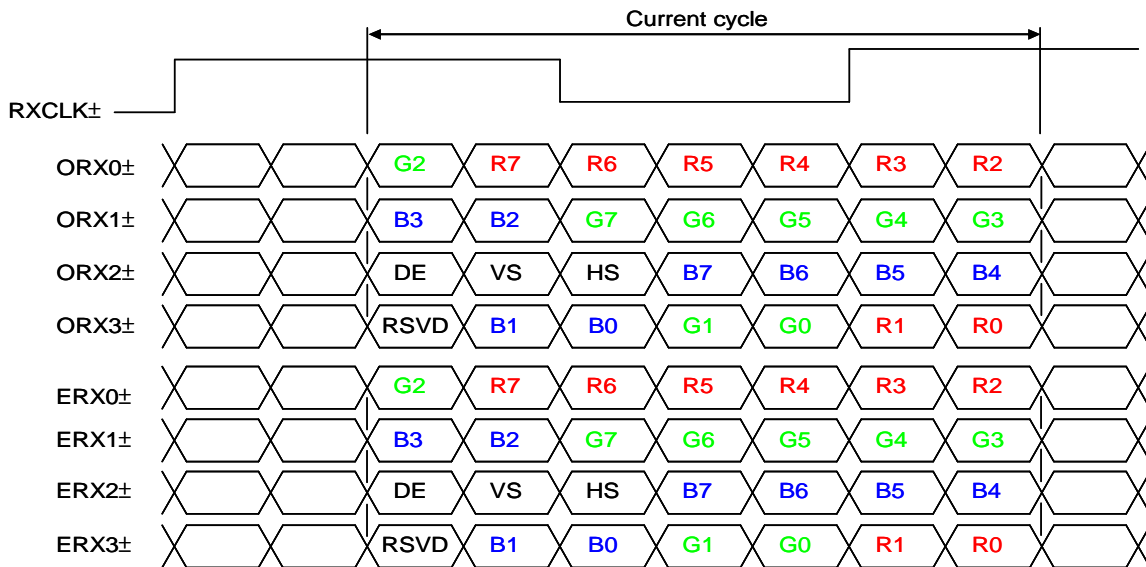

R0~R7	Pixel R Data (7; MSB, 0; LSB)	DE	Data enable signal
G0~G7	Pixel G Data (7; MSB, 0; LSB)	DCLK	Data clock signal
B0~B7	Pixel B Data (7; MSB, 0; LSB)		

Note (1) RSVD (reserved) pins on the transmitter shall be "H" or "L".

4.4 COLOR DATA INPUT ASSIGNMENT

The brightness of each primary color (red, green and blue) is based on the 8-bit gray scale data input for the color. The higher the binary input, the brighter the color. The table below provides the assignment of the color versus data input.

Color		Data Signal																							
		Red								Green								Blue							
		R7	R6	R5	R4	R3	R2	R1	R0	G7	G6	G5	G4	G3	G2	G1	G0	B7	B6	B5	B4	B3	B2	B1	B0
Basic Colors	Black	0	0	0	0	0	0	0	0	0	0	0	0	0	0	0	0	0	0	0	0	0	0	0	
	Red	1	1	1	1	1	1	1	1	0	0	0	0	0	0	0	0	0	0	0	0	0	0	0	
	Green	0	0	0	0	0	0	0	0	1	1	1	1	1	1	1	1	0	0	0	0	0	0	0	
	Blue	0	0	0	0	0	0	0	0	0	0	0	0	0	0	0	0	1	1	1	1	1	1	1	
	Cyan	0	0	0	0	0	0	0	0	1	1	1	1	1	1	1	1	1	1	1	1	1	1	1	
	Magenta	1	1	1	1	1	1	1	1	0	0	0	0	0	0	0	0	1	1	1	1	1	1	1	
	Yellow	1	1	1	1	1	1	1	1	1	1	1	1	1	1	1	1	0	0	0	0	0	0	0	
	White	1	1	1	1	1	1	1	1	1	1	1	1	1	1	1	1	1	1	1	1	1	1	1	
Gray Scale Of Red	Red (0) / Dark	0	0	0	0	0	0	0	0	0	0	0	0	0	0	0	0	0	0	0	0	0	0		
	Red (1)	0	0	0	0	0	0	0	1	0	0	0	0	0	0	0	0	0	0	0	0	0	0		
	Red (2)	0	0	0	0	0	0	1	0	0	0	0	0	0	0	0	0	0	0	0	0	0	0		
	:	:	:	:	:	:	:	:	:	:	:	:	:	:	:	:	:	:	:	:	:	:	:		
	:	:	:	:	:	:	:	:	:	:	:	:	:	:	:	:	:	:	:	:	:	:	:		
	Red (253)	1	1	1	1	1	1	0	1	0	0	0	0	0	0	0	0	0	0	0	0	0	0		
	Red (254)	1	1	1	1	1	1	1	0	0	0	0	0	0	0	0	0	0	0	0	0	0	0		
	Red (255)	1	1	1	1	1	1	1	1	0	0	0	0	0	0	0	0	0	0	0	0	0	0		
Gray Scale Of Green	Green (0) / Dark	0	0	0	0	0	0	0	0	0	0	0	0	0	0	0	0	0	0	0	0	0	0		
	Green (1)	0	0	0	0	0	0	0	0	0	0	0	0	0	0	0	1	0	0	0	0	0	0		
	Green (2)	0	0	0	0	0	0	0	0	0	0	0	0	0	0	1	0	0	0	0	0	0	0		
	:	:	:	:	:	:	:	:	:	:	:	:	:	:	:	:	:	:	:	:	:	:	:		
	:	:	:	:	:	:	:	:	:	:	:	:	:	:	:	:	:	:	:	:	:	:	:		
	Green (253)	0	0	0	0	0	0	0	0	1	1	1	1	1	1	0	1	0	0	0	0	0	0		
	Green (254)	0	0	0	0	0	0	0	0	1	1	1	1	1	1	1	0	0	0	0	0	0	0		
	Green (255)	0	0	0	0	0	0	0	0	1	1	1	1	1	1	1	0	0	0	0	0	0	0		
Gray Scale Of Blue	Blue (0) / Dark	0	0	0	0	0	0	0	0	0	0	0	0	0	0	0	0	0	0	0	0	0	0		
	Blue (1)	0	0	0	0	0	0	0	0	0	0	0	0	0	0	0	0	0	0	0	0	0	1		
	Blue (2)	0	0	0	0	0	0	0	0	0	0	0	0	0	0	0	0	0	0	0	0	0	1		
	:	:	:	:	:	:	:	:	:	:	:	:	:	:	:	:	:	:	:	:	:	:	:		
	:	:	:	:	:	:	:	:	:	:	:	:	:	:	:	:	:	:	:	:	:	:	:		
	Blue (253)	0	0	0	0	0	0	0	0	0	0	0	0	0	0	0	0	1	1	1	1	1	1		
	Blue (254)	0	0	0	0	0	0	0	0	0	0	0	0	0	0	0	0	1	1	1	1	1	1		
	Blue (255)	0	0	0	0	0	0	0	0	0	0	0	0	0	0	0	0	1	1	1	1	1	1		

Note (1) 0: Low Level Voltage, 1: High Level Voltage

5. INTERFACE TIMING

5.1 INPUT SIGNAL TIMING SPECIFICATIONS

The input signal timing specifications are shown as the following table and timing diagram.

Signal	Item	Symbol	Min.	Typ.	Max.	Unit	Note
LVDS Receiver Clock	Frequency	$F_{clk_{in}}$ (=1/TC)	60	74.25	80	MHz	
	Input cycle to cycle jitter	T_{rc1}	—	—	200	ps	(3)
	Spread spectrum modulation range	$F_{clk_{in_mod}}$	$F_{clk_{in}}-2\%$	—	$F_{clk_{in}}+2\%$	MHz	(4)
	Spread spectrum modulation frequency	F_{SSM}	—	—	200	KHz	
LVDS Receiver Data	Receiver Skew Margin	T_{RSKM}	-400	—	400	ps	(5)
Frame Rate		F_{r5}	47	50	53	Hz	
		F_{r6}	57	60	63	Hz	
Horizontal Frequency		F_h	45.3	67.5	71.3	KHz	
Vertical Active Display Term	Total	T_v	1100	1125	1480	Th	$T_v=T_{vd}+T_{vb}$
	Display	T_{vd}	1080	1080	1080	Th	
	Blank	T_{vb}	20	45	400	Th	
Horizontal Active Display Term	Total	T_h	1030	1100	1325	Tc	$T_h=T_{hd}+T_{hb}$
	Display	T_{hd}	960	960	960	Tc	
	Blank	T_{hb}	70	140	365	Tc	

Note (1) Please make sure the range of frame rate has follow the below equation :

$$F_{clk_{in}}(\max) \geq Fr6 \times Tv \times Th$$

$$Fr5 \times Tv \times Th \geq F_{clk_{in}}(\min)$$

Note (2) This module is operated in DE only mode and please follow the input signal timing diagram as below :

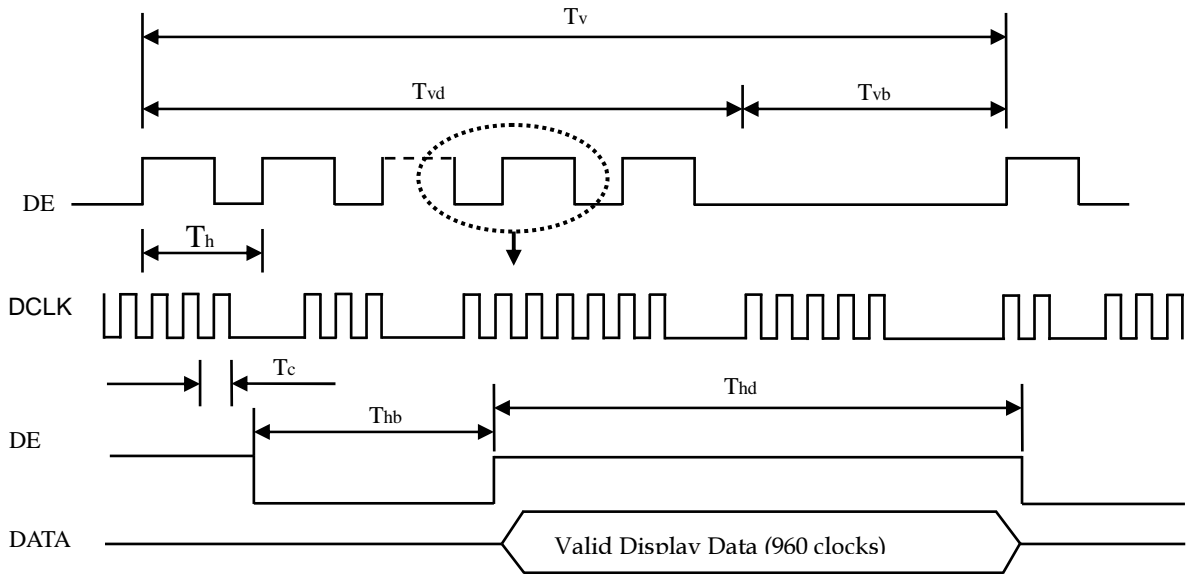

Note (3) The input clock cycle-to-cycle jitter is defined as below figures. $Trcl = |T_1 - T|$

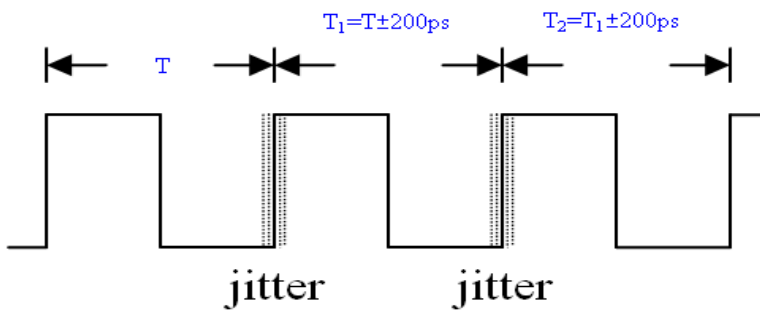

Note (4) The SSCG (Spread spectrum clock generator) is defined as below figures.

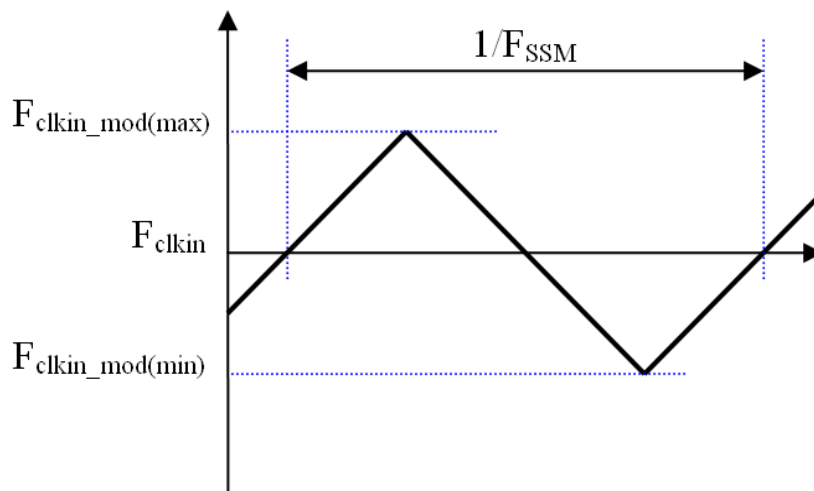

Note (5) The LVDS timing diagram and the receiver skew margin is defined and shown in following figure.

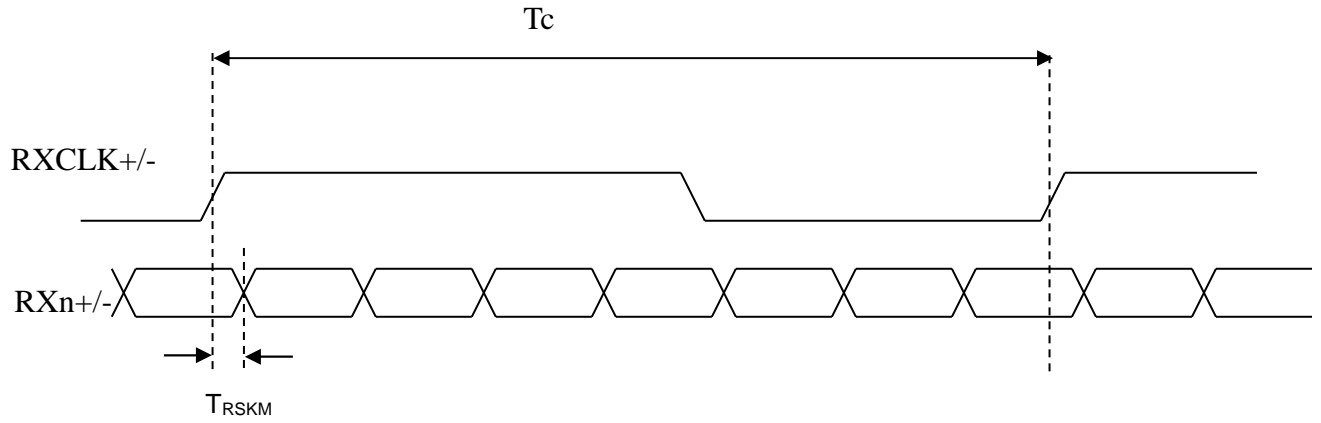

5.2 POWER ON/OFF SEQUENCE

($T_a = 25 \pm 2 \text{ }^\circ\text{C}$)

To prevent a latch-up or DC operation of LCD module, the power on/off sequence should be as the diagram below.

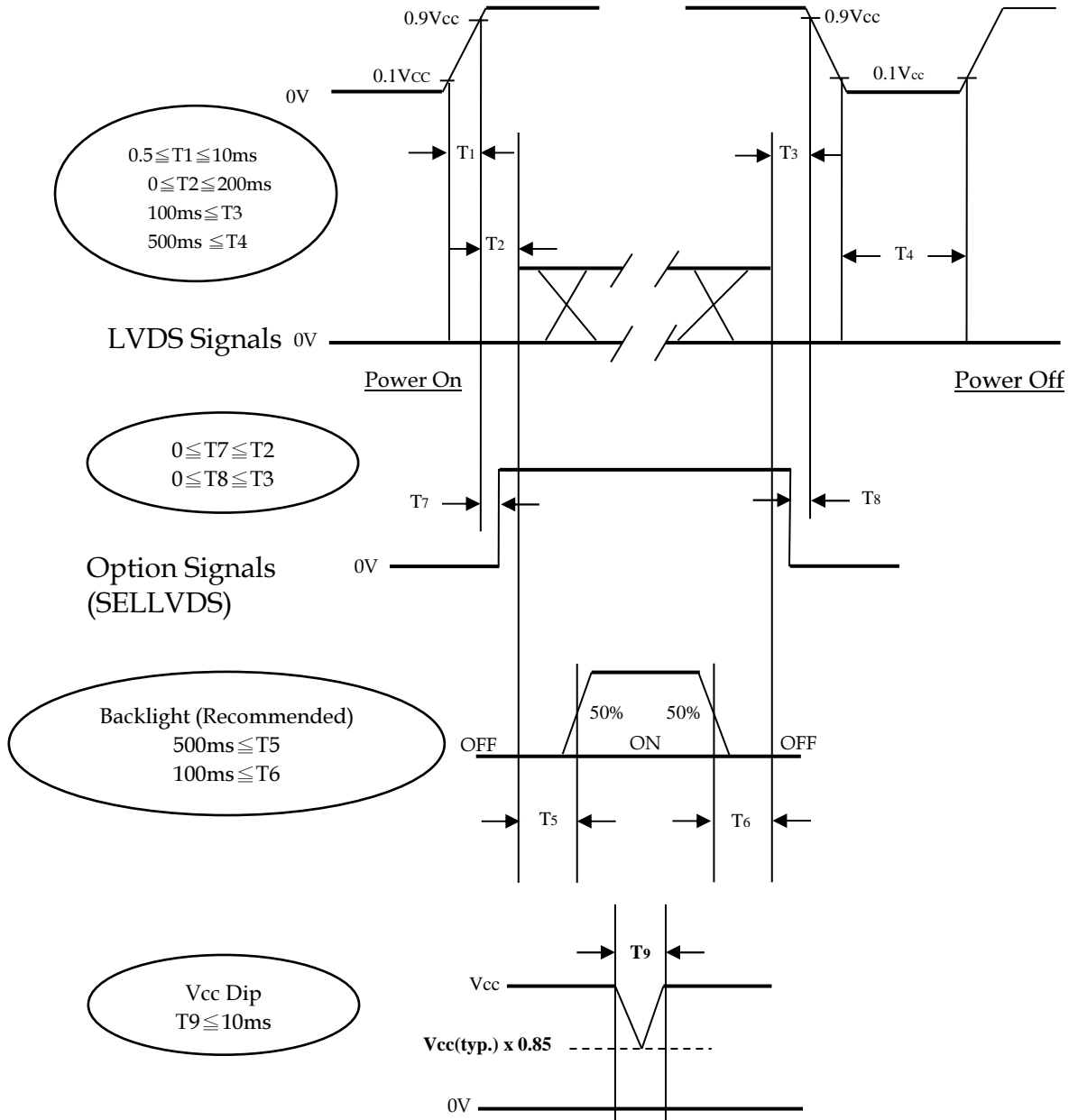

Note (1) The supply voltage of the external system for the module input should follow the definition of Vcc.

Note (2) Apply the LED voltage within the LCD operation range. When the backlight turns on before the LCD operation or the LCD turns off before the backlight turns off, the display may momentarily become abnormal screen.

Note (3) In case of VCC is in off level, please keep the level of input signals on the low or high impedance.

If $T2 < 0$, that may cause electrical overstress failure.

Note (4) T4 should be measured after the module has been fully discharged between power off and on period.

Note (5) Interface signal shall not be kept at high impedance when the power is on.

Note (6) Vcc must decay smoothly when power-off.

6. OPTICAL CHARACTERISTICS

6.1 TEST CONDITIONS

Item	Symbol	Value	Unit
Ambient Temperature	Ta	25±2	°C
Ambient Humidity	Ha	50±10	%RH
Supply Voltage	VCC	12±1.2	V
Input Signal	According to typical value in "3. ELECTRICAL CHARACTERISTICS"		
Vertical Frame Rate	Fr	60	Hz

The LCD module should be stabilized at given temperature for 1 hour to avoid abrupt temperature change during measuring in a windless room.

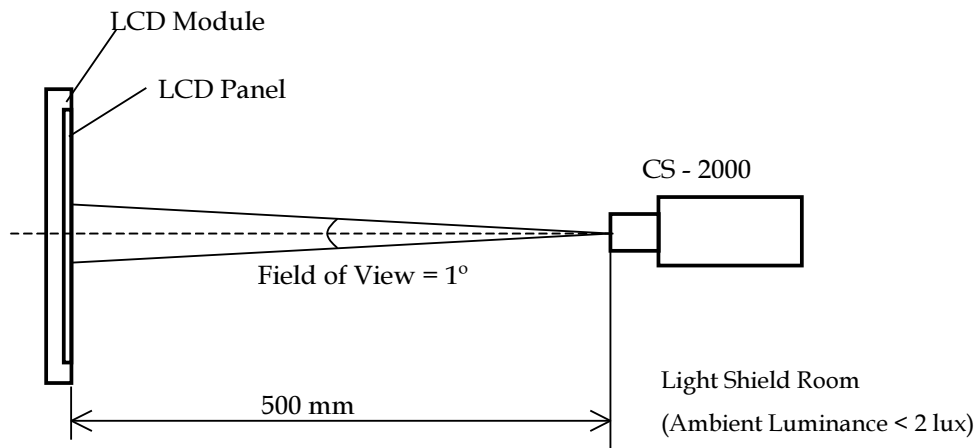

6.2 OPTICAL SPECIFICATIONS

The relative measurement methods of optical characteristics are shown in 6.2. The following items should be measured under the test conditions described in 6.1 and stable environment shown in 6.1.

Item		Symbol	Condition	Min.	Typ.	Max.	Unit	Note				
Contrast Ratio		CR	$\theta_x=0^\circ, \theta_y=0^\circ$ Viewing angle at normal direction	3500	5000	-	-	(2)				
Response Time		Gray to gray			11	22	ms	(3)				
Center Luminance of White		L _C		1600	2000	-	cd/m ²	(4)				
White Variation		δW				1.3	-	(6)				
Cross Talk		CT		-		4	%	(5)				
Color Chromaticity	Red	R _x		0.03	Typ.-	(0.636)	Typ.+	-				
		R _y				(0.336)		-				
	Green	G _x				(0.311)		-				
		G _y				(0.611)		-				
	Blue	B _x				(0.153)		-				
		B _y	(0.055)			-						
	White	W _x	0.280			-						
		W _y	0.290			-						
	Correlated color temperature					-		10000		-	K	
	Color Gamut		C.G.			-		72		-	%	NTSC
Viewing Angle	Horizontal	θ_{x+}	CR \geq 10	80	89	-	Deg.	(1)				
		θ_{x-}										
	Vertical	θ_{y+}										
		θ_{y-}										

Note (1) Definition of Viewing Angle (θ_x, θ_y) :

Viewing angles are measured by Autronic Conoscope Cono-80 (or Eldim EZ-Contrast 160R).

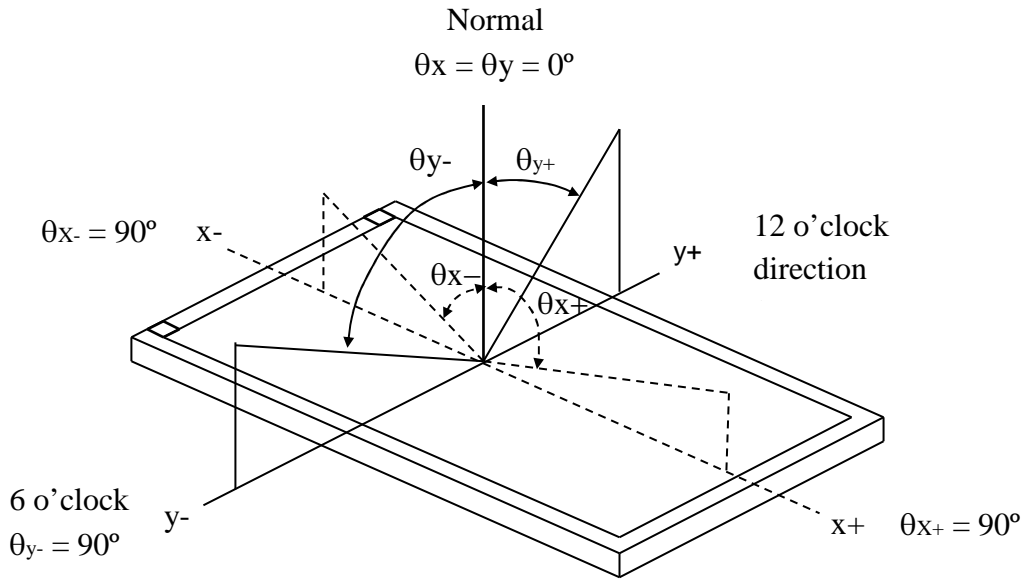

Note (2) Definition of Contrast Ratio (CR) :

The contrast ratio can be calculated by the following expression.

$$\text{Contrast Ratio (CR)} = \frac{\text{Surface Luminance of L255}}{\text{Surface Luminance of L0}}$$

L255: Luminance of gray level 255

L 0: Luminance of gray level 0

CR = CR (X), where CR (X) is corresponding to the Contrast Ratio of the point X at the figure in Note (6).

Note (3) Definition of Gray-to-Gray Switching Time :

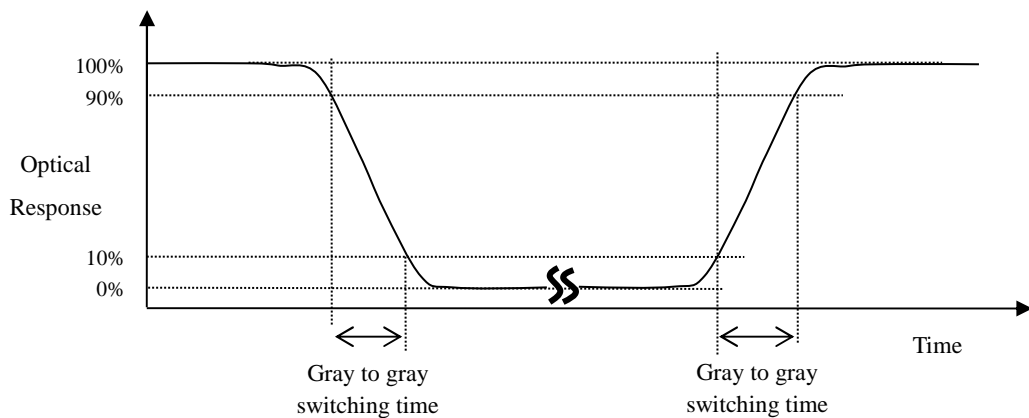

The driving signal means the signal of gray level 0, 31, 63, 95, 127, 159, 191, 223 and 255.

Gray to gray average time means the average switching time of gray level 0, 31, 63, 95, 127, 159, 191, 223 and 255 to each other.

Note (4) Definition of Luminance of White (L_C, L_{AVE}) :

Measure the luminance of gray level 255 at center point and 5 points

$L_C = L(5)$, where $L(X)$ is corresponding to the luminance of the point X at the figure in Note (6).

Note (5) Definition of Cross Talk (CT) :

$$CT = | Y_B - Y_A | / Y_A \times 100 (\%)$$

Where:

Y_A = Luminance of measured location without gray level 255 pattern (cd/m²)

Y_B = Luminance of measured location with gray level 255 pattern (cd/m²)

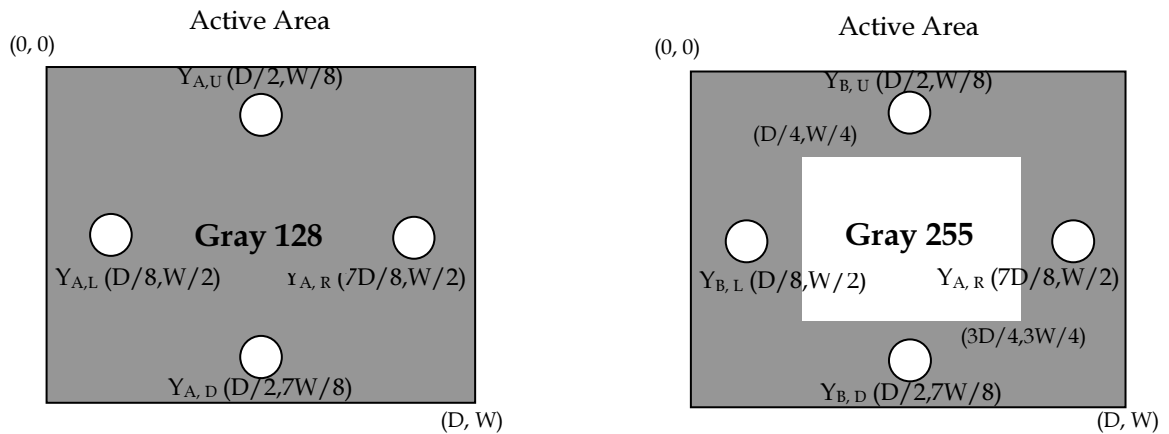

Note (6) Definition of White Variation (δW) :

Measure the luminance of gray level 255 at 5 points

$$\delta W = \frac{\text{Maximum } [L(1), L(2), L(3), L(4), L(5)]}{\text{Minimum } [L(1), L(2), L(3), L(4), L(5)]}$$

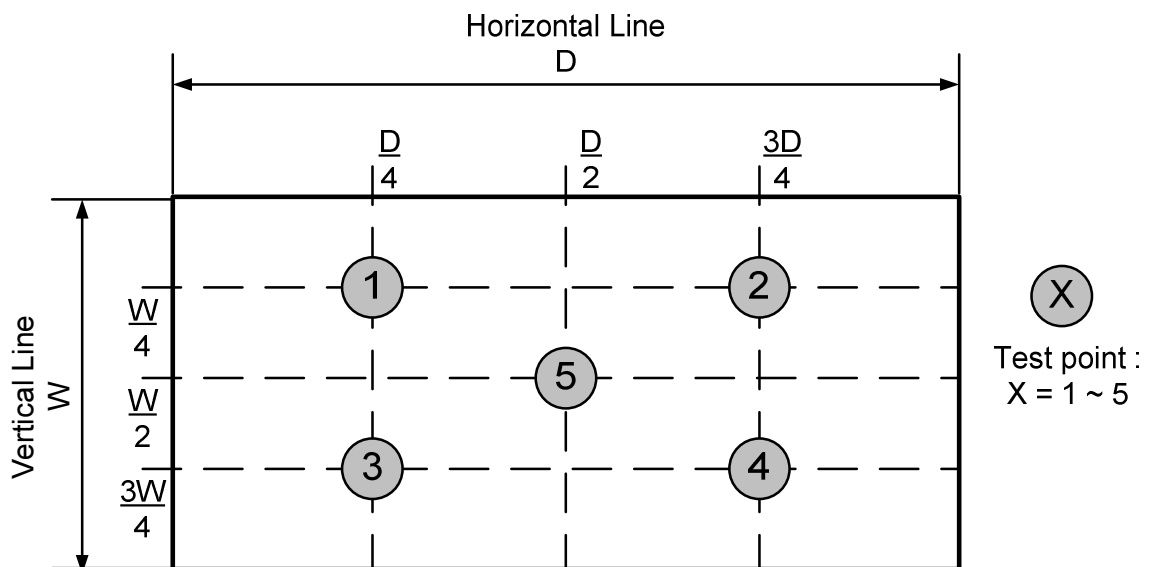

7. PRECAUTIONS

7.1 SAFETY PRECAUTIONS

To optimize the lifetime and functions of PID SET, operating conditions should be followed as below

- [1] Normal operating condition
 - [1.1] Well-ventilated place is suggested to set up PID Set and system.
 - [1.2] Display pattern: regular switched patterns or moving pictures.
- [2] Operation usage to protect against image sticking due to long-term static display.
 - [2.1] Liquid Crystal refresh time is required. Cycling display between 5 minutes' information (static)display and 10 seconds' moving image.
 - [2.2] Periodical display contents should be changed from static image to moving picture.
 - [2.2.1] Different background and image colors changed respectively, and changed colors periodically.
 - [2.2.2] Background and image with large different luminance displayed at the same time should be avoided.
 - [2.2.3] Periodical power-off the system for a while or screen saver is needed after long-term static display.
 - [2.2.4] Moving picture or black pattern is strongly recommended for screen saver.
- [3] The startup voltage of a Backlight may cause an electrical shock while assembling with the converter.
Do not disassemble the module or insert anything into the Backlight unit.
- [4] Do not connect or disconnect the module in the "Power On" condition.
- [5] Do not exceed the absolute maximum rating value. (supply voltage variation, input voltage variation, variation in part contents and environmental temperature...) Otherwise the module may be damaged.
- [6] If the liquid crystal material leaks from the panel, it should be kept away from the eyes or mouth. In case of contact with hands, skin or clothes, it has to be washed away thoroughly with soap.
- [7] Product reliability and functions are only guaranteed when the product is used under right operation usages. If product will be used in extreme conditions, especially combining severe conditions such as high temperature/humidity, display stationary patterns, or long operation time etc..., it is strongly recommended to contact INX for field application engineering advice. Otherwise, the panel may be damaged and its reliability and function may not be guaranteed. Extreme conditions are commonly found at airports, transit stations, banks, stock market and full outdoor display.
- [8] LCD system is required to place in well-ventilated environment. Adapting active cooling system is highly recommended.
- [9] Module should be turned clockwise (regular front view perspective) when used in portrait mode.

7.2 PRECAUTIONS FOR STRONG LIGHT EXPOSURE

- [1] Strong light exposure causes degradation of polarizer and color filter. Since the product design is not protected by an ultra-violet ray filter, the deterioration of the polarizer due to sun exposure or water drenching is not guarantee.

7.3 SAFETY STANDARDS

The LCD module should be certified with safety regulations as follows:

Regulatory	Item	Standard
Audio/video, Information and Communication Technology Equipment	UL	UL 62368-1, 3rd Edition, 2021-10-22
	cUL	CAN/CSA C22.2 No. 62368-1:19, 3rd Edition, 2021-10-22
	CB	IEC 62368-1:2018 EN IEC 62368-1:2020+A11:2020

If the module displays the same pattern for a long period of time, the phenomenon of image sticking may be occurred.

8. DEFINITION OF LABELS

8.1 MODULE LABEL

The barcode nameplate is pasted on each module as illustration, and its definitions are as following explanation.

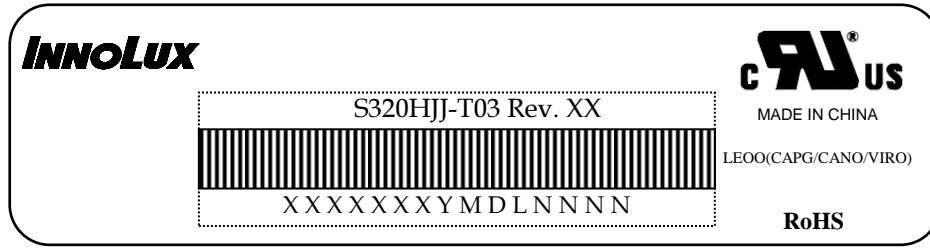

- (a) Model Name: S320HJJ-T03
- (b) Revision: Rev. XX, for example: A0, A1... B1, B2... or C1, C2...etc.
- (c) Serial ID: XXXXXXYMDLNNNN

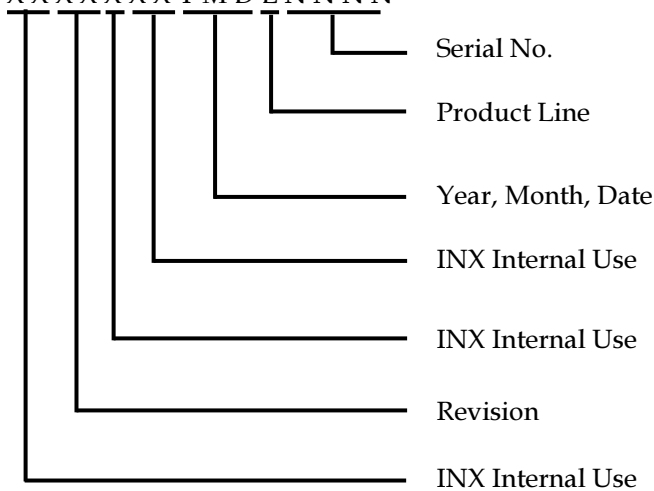

Serial ID includes the information as below:

- (a) Manufactured Date: Year: 0~9, for 2010~2019
Month: 1~9, A~C, for Jan. ~ Dec.
Day: 1~9, A~Y, for 1st to 31st, exclude I ,O, and U.
- (b) Revision Code: Cover all the change
- (c) Serial No.: Manufacturing sequence of product
- (d) Product Line: 1 → Line1, 2 → Line 2, ...etc.

8.2 CARTON LABEL

The barcode nameplate is pasted on each box as illustration, and its definitions are as following explanation.

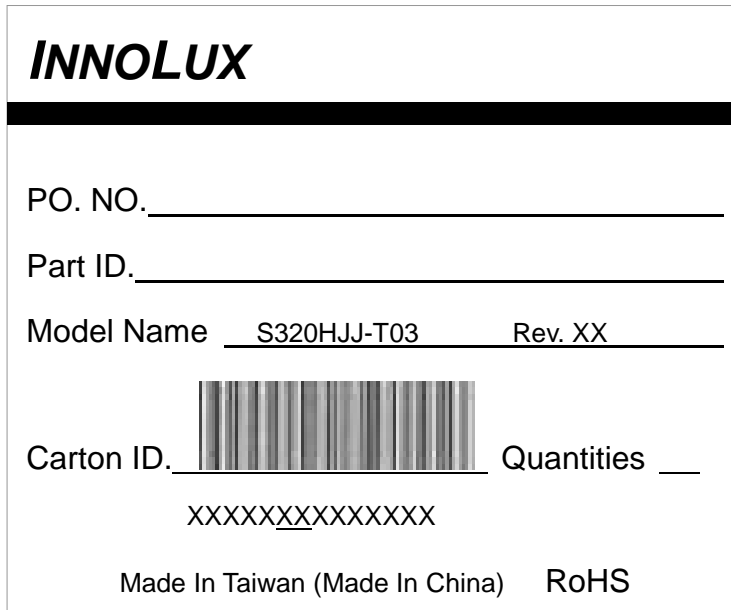

Model Name: S320HJJ-T03

Carton ID: X X X X X X Y M D X X X X

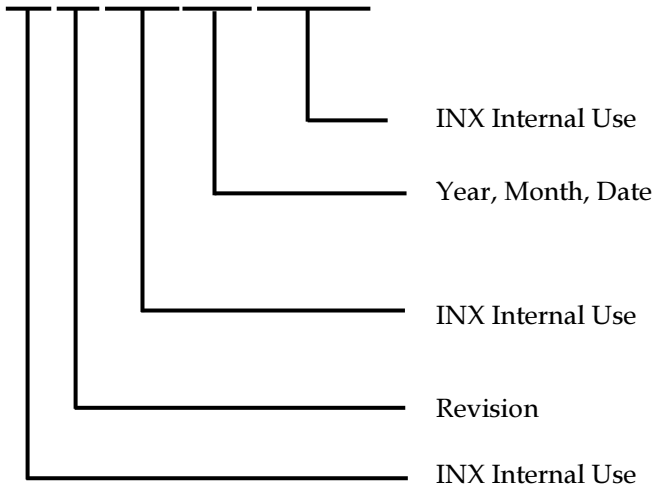

Serial ID includes the information as below :

Manufactured Date:

Year: 2010=0, 2011=1, 2012=2...etc.

Month: 1~9, A~C, for Jan. ~ Dec.

Day: 1~9, A~Y, for 1st to 31st, exclude I, O, and U.

Revision Code: Cover all the change

9. PACKAGING

9.1 PACKAGING SPECIFICATIONS

- (1) 8 LCD TV modules / 1 Box
- (2) Box dimensions : 830(L) X 565 (W) X 531 (H)
- (3) Weight: approximately 42 Kg (8 modules per box)

9.2 PACKAGING METHOD

Packaging method is shown in following figures

Packing (1) Carton dimensions: 830(L)x565(W)x531(H)mm
(2) 8 PID Mod / Carton

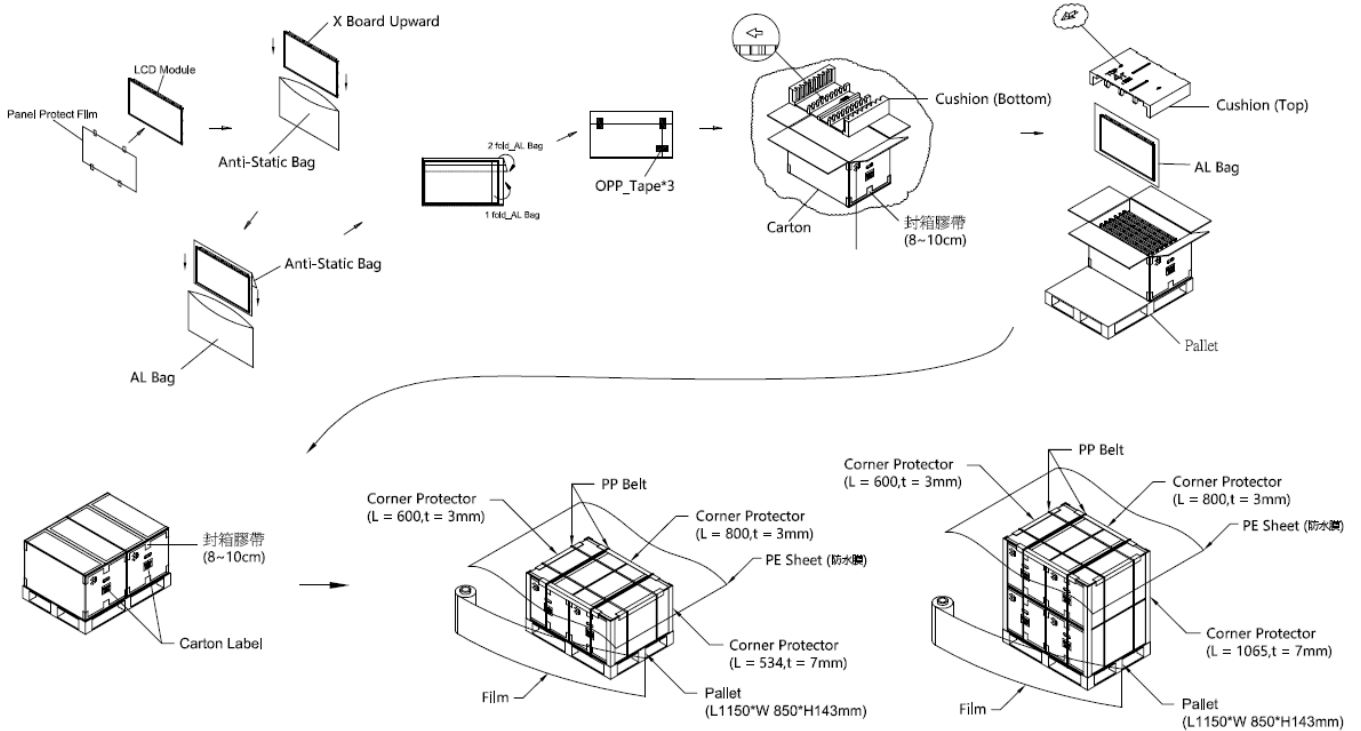

Air Transportation
單棧堆疊(2 Layers)

Sea / Land Transportation
(40ft HQ)
上,下棧堆疊(2+2 Layers)

Sea / Land Transportation
(40ft Container)
上,下棧堆疊(2+1 Layers)

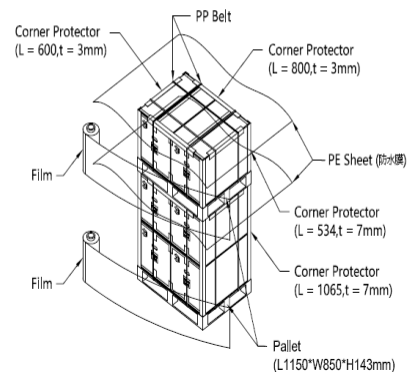
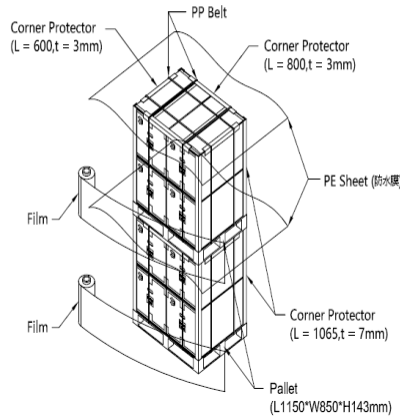
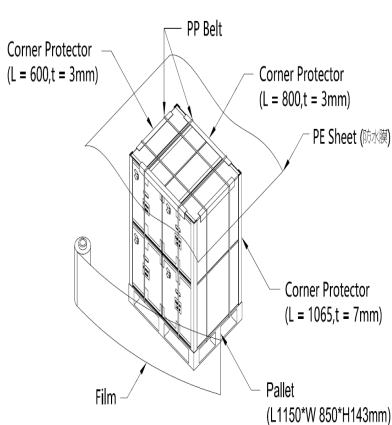

9.3 UN-PACKAGING METHOD

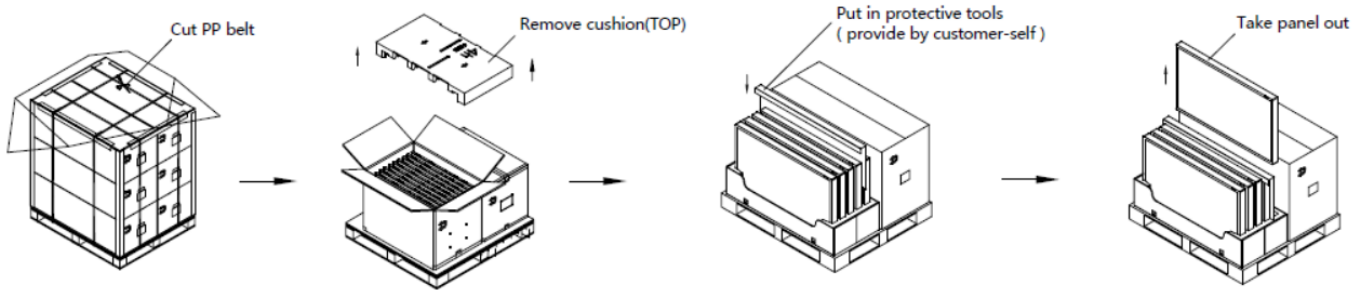

10. MECHANICAL CHARACTERISTIC

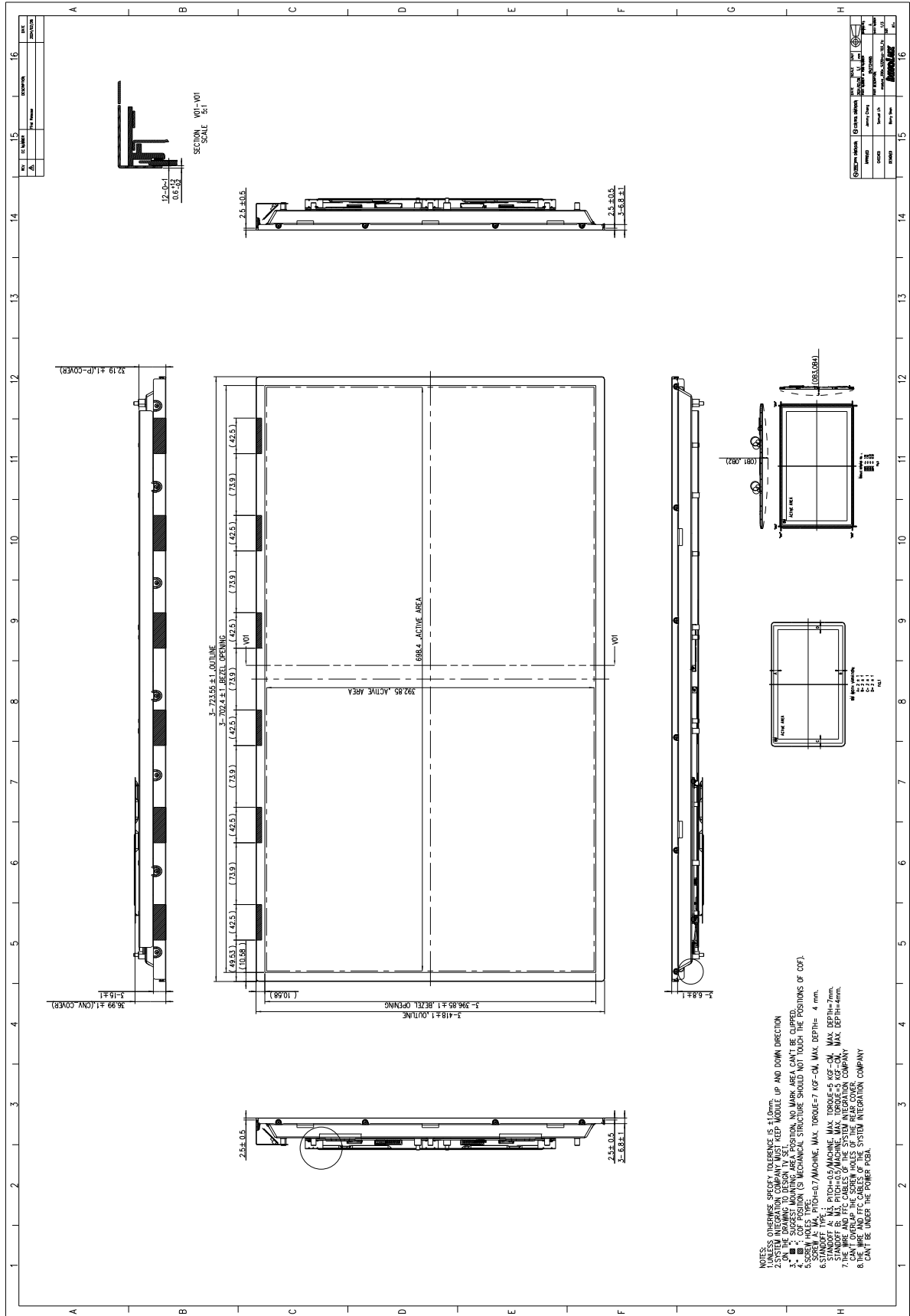

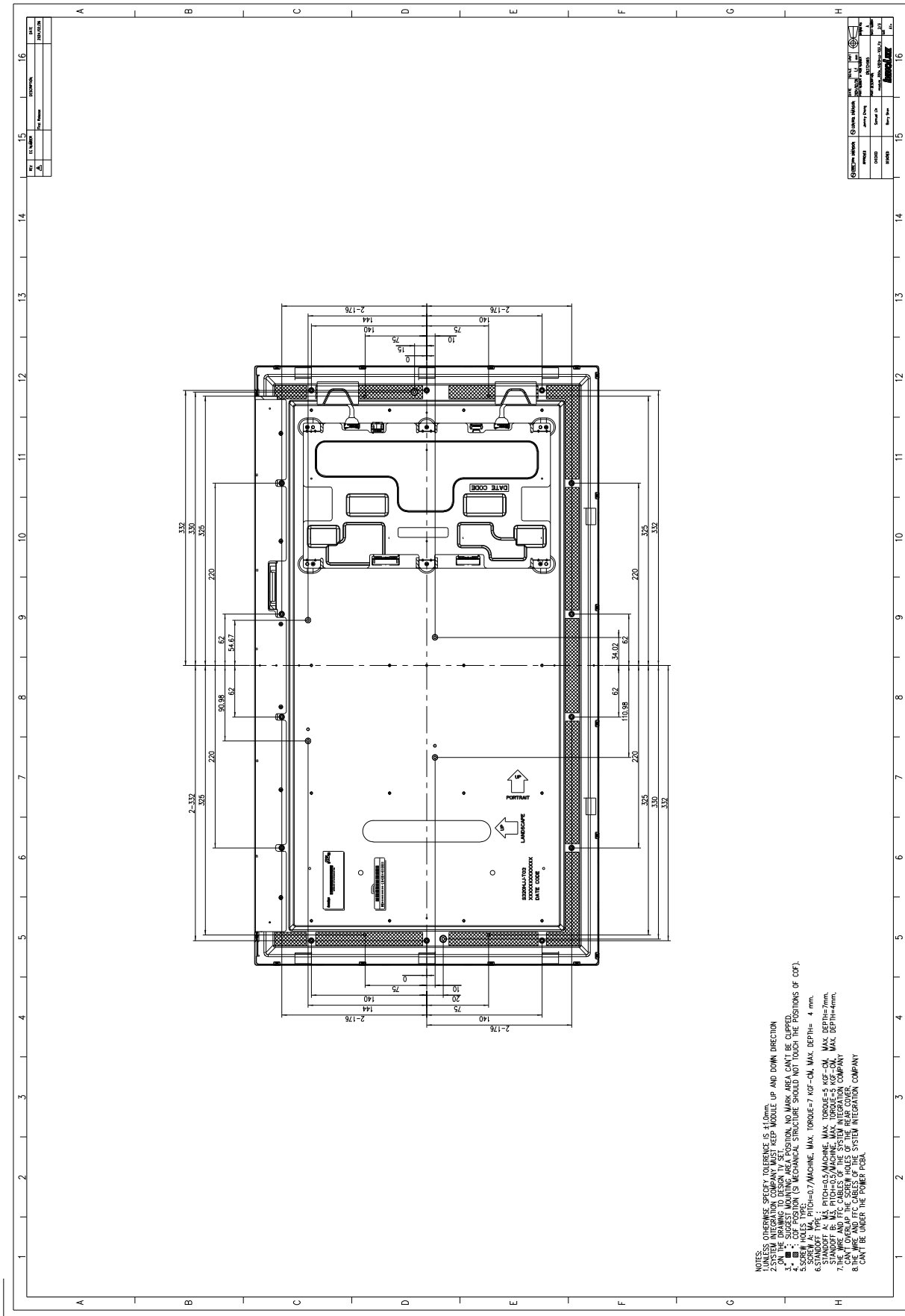

- NOTES:
- UNLESS OTHERWISE SPECIFY TOLERANCE IS ±1.0mm.
 - SYSTEM INTEGRATION COMPANY MUST KEEP MODULE UP AND DOWN DIRECTION.
 - NO MARK AREA CAN'T BE CLIPPED.
 - SUGGEST MOUNTING AREA POSITION, NO MARK AREA CAN'T BE CLIPPED.
 - COF POSITION (S MECHANICAL STRUCTURE SHOULD NOT TOUCH THE POSITION OF COF).
 - COF POSITION (S MECHANICAL STRUCTURE SHOULD NOT TOUCH THE POSITION OF COF).
 - COF POSITION (S MECHANICAL STRUCTURE SHOULD NOT TOUCH THE POSITION OF COF).
 - COF POSITION (S MECHANICAL STRUCTURE SHOULD NOT TOUCH THE POSITION OF COF).
 - COF POSITION (S MECHANICAL STRUCTURE SHOULD NOT TOUCH THE POSITION OF COF).
 - COF POSITION (S MECHANICAL STRUCTURE SHOULD NOT TOUCH THE POSITION OF COF).
 - COF POSITION (S MECHANICAL STRUCTURE SHOULD NOT TOUCH THE POSITION OF COF).
 - COF POSITION (S MECHANICAL STRUCTURE SHOULD NOT TOUCH THE POSITION OF COF).
 - COF POSITION (S MECHANICAL STRUCTURE SHOULD NOT TOUCH THE POSITION OF COF).
 - COF POSITION (S MECHANICAL STRUCTURE SHOULD NOT TOUCH THE POSITION OF COF).
 - COF POSITION (S MECHANICAL STRUCTURE SHOULD NOT TOUCH THE POSITION OF COF).

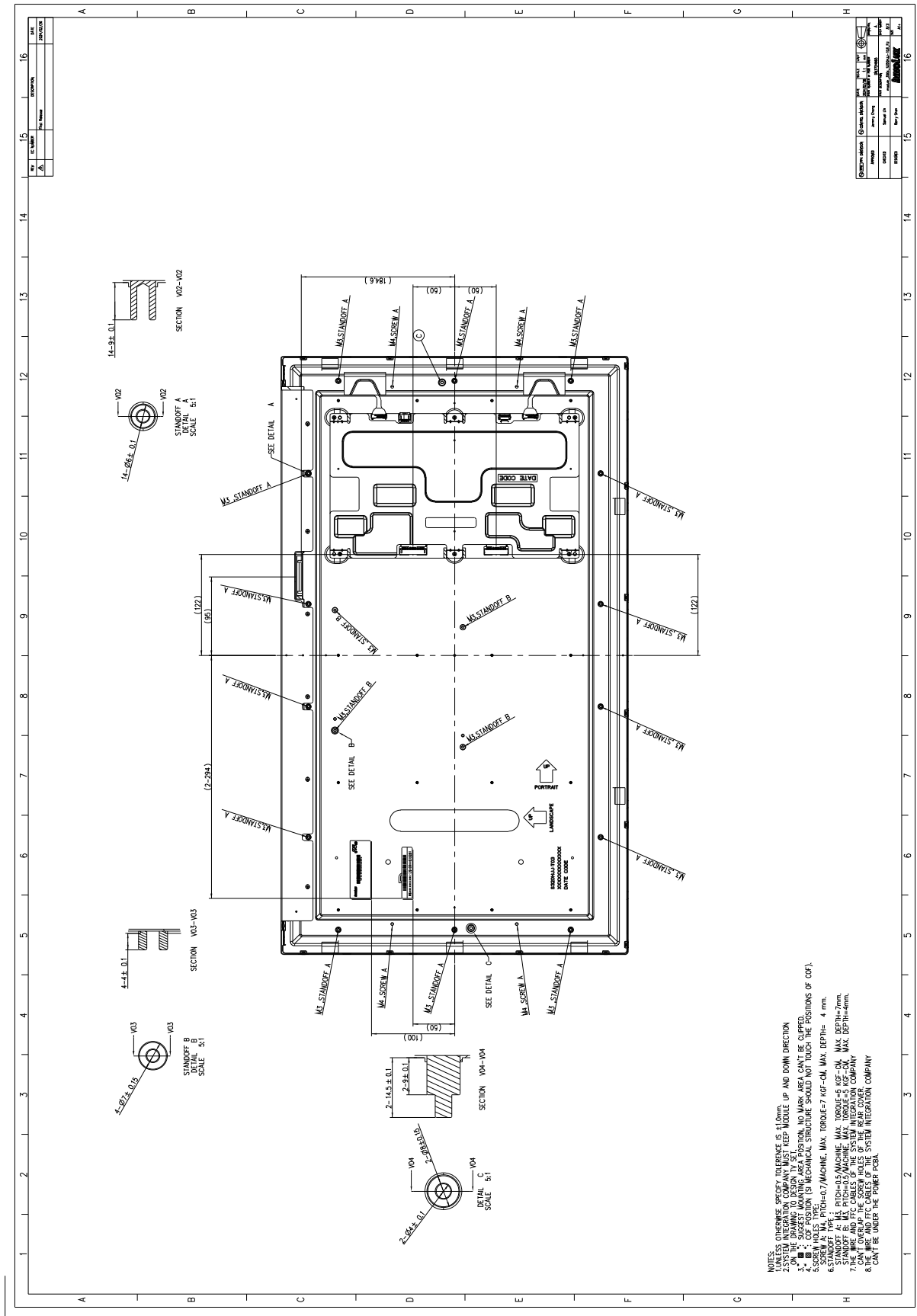

NOTES:
 1. DIMENSIONS SPECIFY TOLERANCE IS ±0.1mm.
 2. SYSTEM INTEGRATION COMPANY MUST KEEP MODULE UP AND DOWN DIRECTION.
 3. THE DRAWING TO DESIGN BY SYSTEM INTEGRATION COMPANY MUST KEEP THE POSITION, NO MARK AREA CAN'T BE CLIPPED.
 4. THE POSITION OF THE DATE CODE MUST BE IN THE POSITION OF THE DATE CODE.
 5. SCREEN A: MAX. PITCH=0.7/MACHINE, MAX. TORQUE=7 KGf-CM, MAX. DEPTH= 4 mm.
 6. STANDOFF A: PITCH=0.5/MACHINE, MAX. TORQUE=5 KGf-CM, MAX. DEPTH=7mm.
 7. STANDOFF B: MAX. PITCH=0.5/MACHINE, MAX. TORQUE=5 KGf-CM, MAX. DEPTH=4mm.
 8. THE WIRE AND FFC CABLES OF THE SYSTEM INTEGRATION COMPANY CAN'T BE UNDER THE POWER PCB.