

**SF2223D**

**184.32 MHz  
SAW Filter**

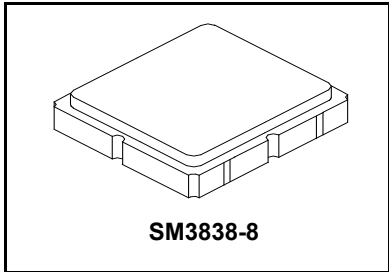

- **High Performance SAW Filter**
- **3.8 x 3.8 x 1.4 mm Surface-mount Package**
- **Complies with Directive 2002/95/EC (RoHS)**



**Absolute Maximum Ratings**

Rating	Value	Units
Maximum Incident Power in Passband	+10	dBm
Maximum DC Voltage Between any Two Active Terminals	30	VDC
Storage Temperature Range in Tape and Reel	-40 to +85	°C
Operating Temperature Range	-40 to +85	°C
Suitable for Lead-free Soldering - Maximum Soldering Profile	260 °C for 30 s	

**Electrical Characteristics**

Characteristic	Sym	Notes	Min	Typ	Max	Units
Nominal Center Frequency	$f_c$			184.32		MHz
Minimum Insertion Loss	$IL_{MIN}$			8.5	10.0	dB
1 dB Bandwidth	$BW_1$		30	32		MHz
Amplitude Ripple, 169.32 to 199.32 MHz				0.6	1.0	dB <sub>P-P</sub>
Group Delay Ripple, 169.32 to 199.32 MHz				18	50	ns <sub>P-P</sub>
Rejection referenced to $IL_{MIN}$ :						
1.00 to 137.88 MHz			45	60		dB
149.32 MHz			16.5	60		
219.32 MHz			16.5	60		
261.48 to 600.00 MHz			45	50		

Case Style	SM3838-8 3.8 x 3.8 mm Nominal Footprint	
Lid Symbolization, Y=year, WW=week, S=shift, Dot=pin 1 indicator	959, YWWS	
Standard Reel Quantity	Reel Size 7 Inch	500 Pieces/Reel
	Reel Size 13 Inch	3000 Pieces/Reel

**Electrical Connections**

Connection	Terminals
Balanced Input Option	1 and 2
Single-ended Input Option	1
Output	5
Case Ground	All others



**CAUTION: Electrostatic Sensitive Device. Observe precautions for handling.**

**NOTES:**

1. Unless noted otherwise, all specifications apply over the operating temperature range with filter soldered to the specified demonstration board with impedance matching to 50 Ω and measured with 50 Ω network analyzer.
2. Unless noted otherwise, all frequency specifications are referenced to the nominal center frequency,  $f_c$ .
3. Rejection is measured as attenuation below the minimum IL point in the passband. Rejection in final user application is dependent on PCB layout and external impedance matching design. See Application Note No. 42 for details.
4. "LRIP" or "L" after the part number indicates "low rate initial production" and "ENG" or "E" indicates "engineering prototypes."
5. The design, manufacturing process, and specifications of this filter are subject to change.
6. Either Port 1 or Port 2 may be used for either input or output in the design. However, impedances and impedance matching may vary between Port 1 and Port 2, so that the filter must always be installed in one direction per the circuit design.
7. US and international patents may apply.
8. Murata, stylized Murata logo, and Murata N.A., Inc. are registered trademarks of Murata Manufacturing Co., Ltd.

# Filter Amplitude and Impedance Plots for Balanced Input

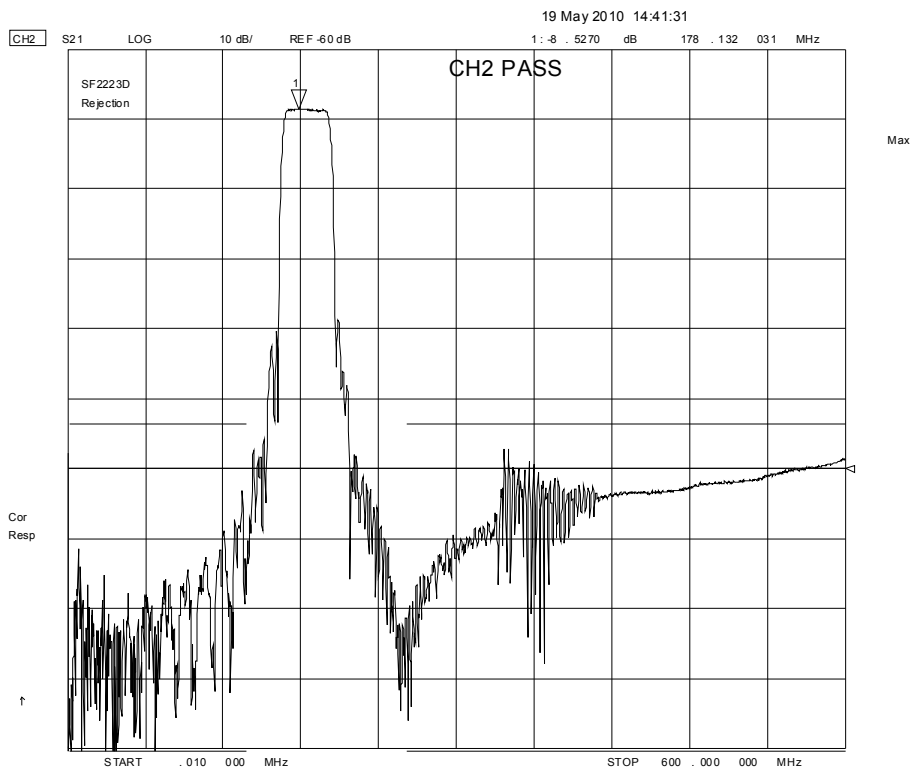
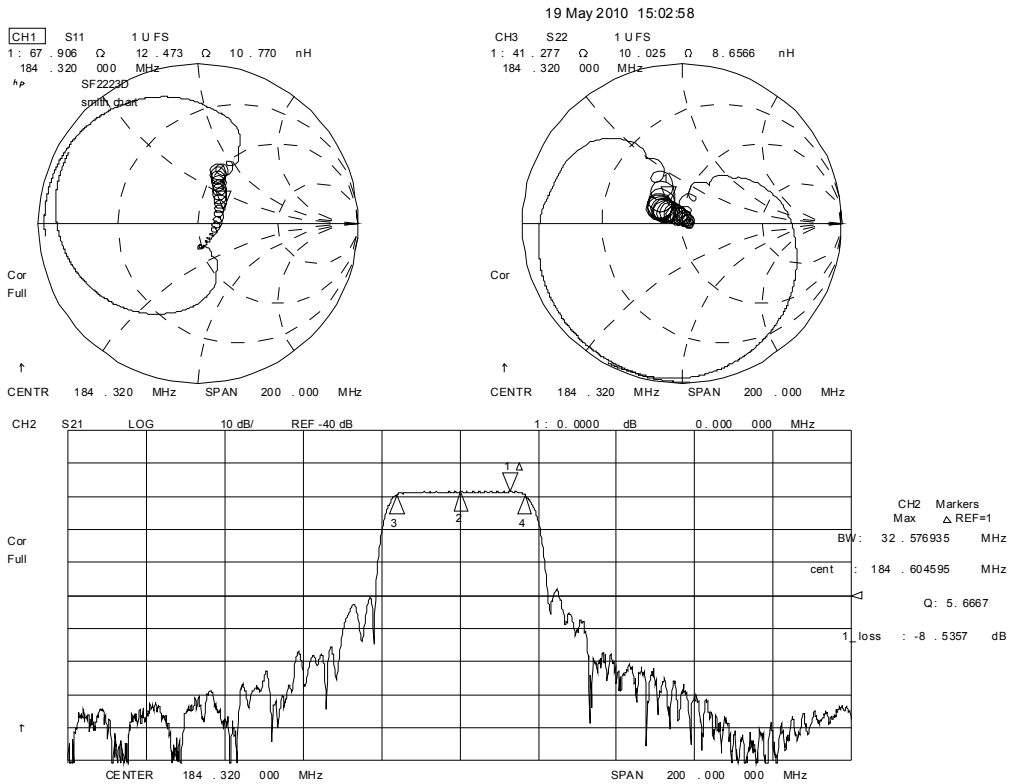

# Filter Passband Group Delay and Amplitude Plots for Balanced Input

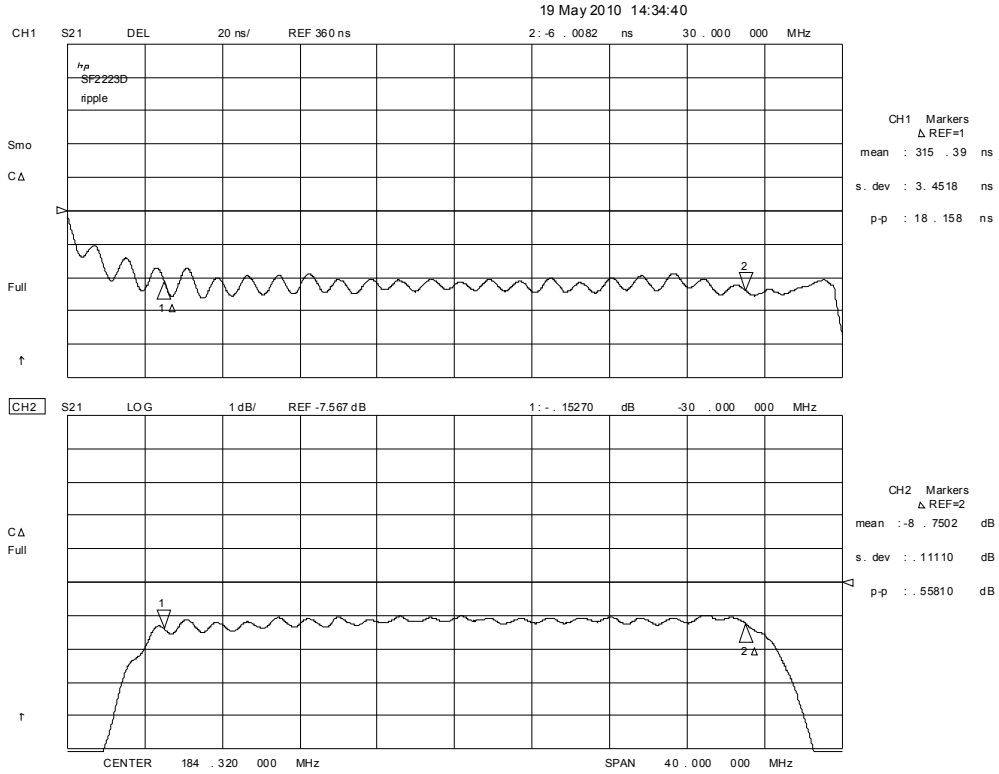

## Balanced Input Filter Test Circuit

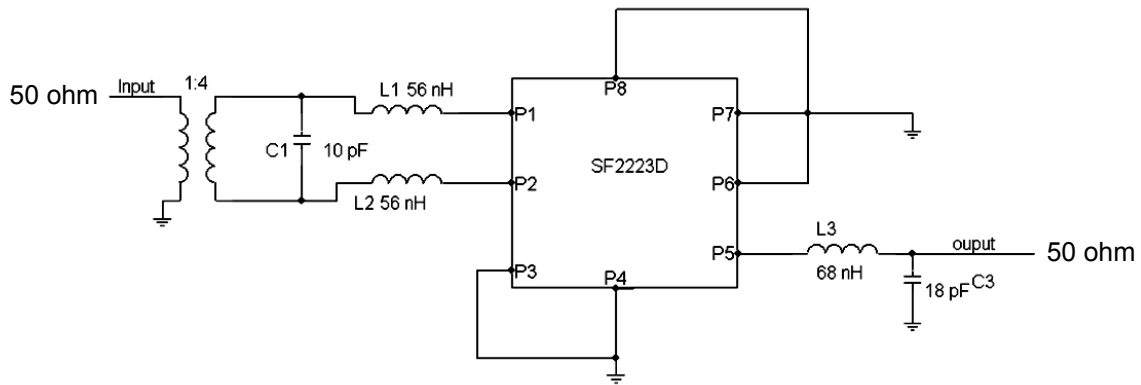

# Filter Amplitude and Impedance Plots for Single-ended Input

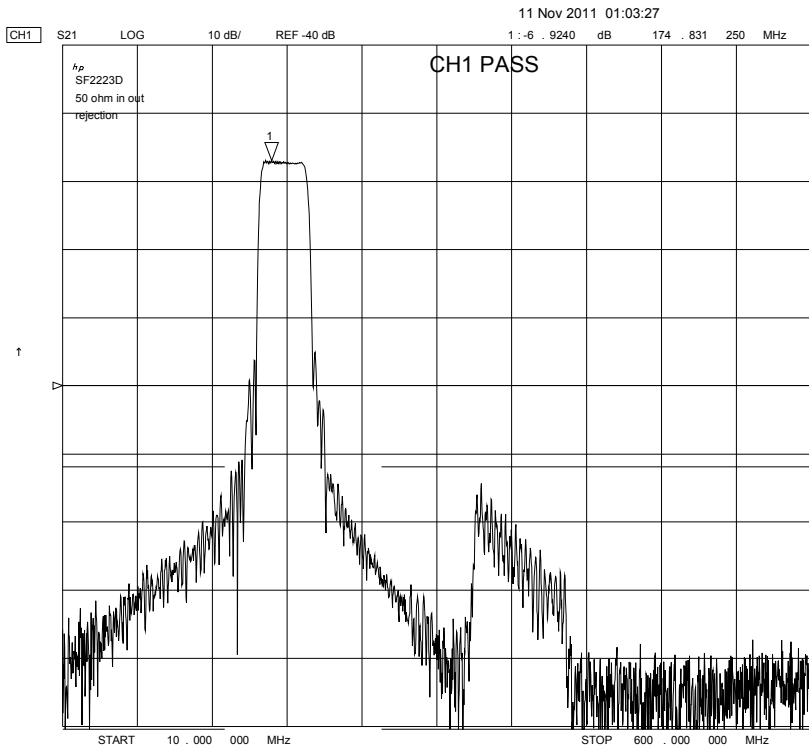
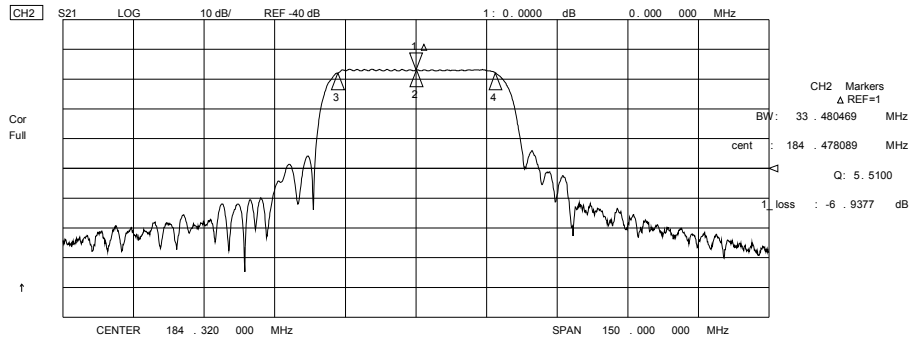
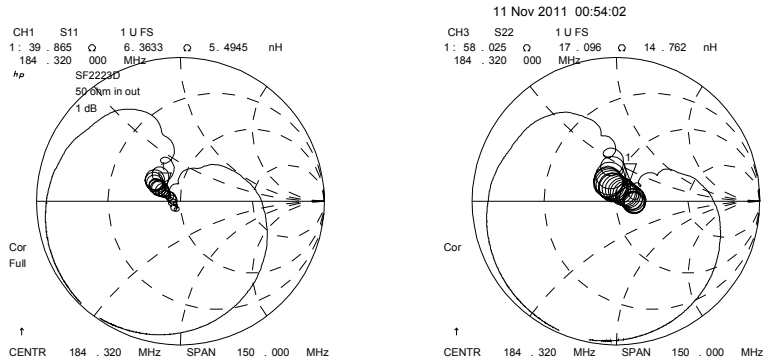

## Filter Passband Group Delay and Amplitude Plots for Single-ended Input

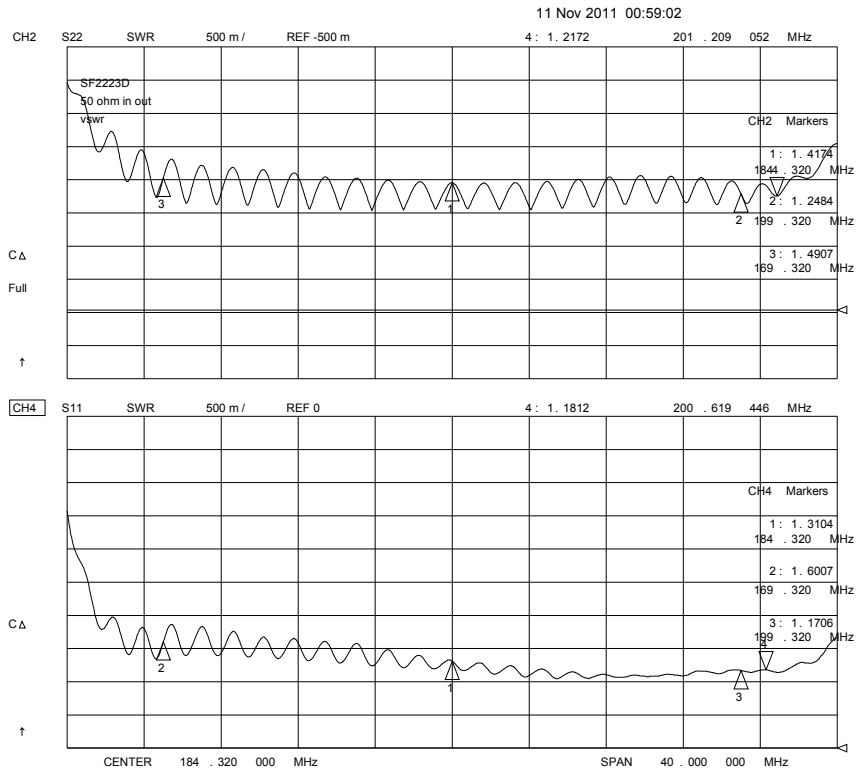

## Single-ended Input Filter Test Circuit

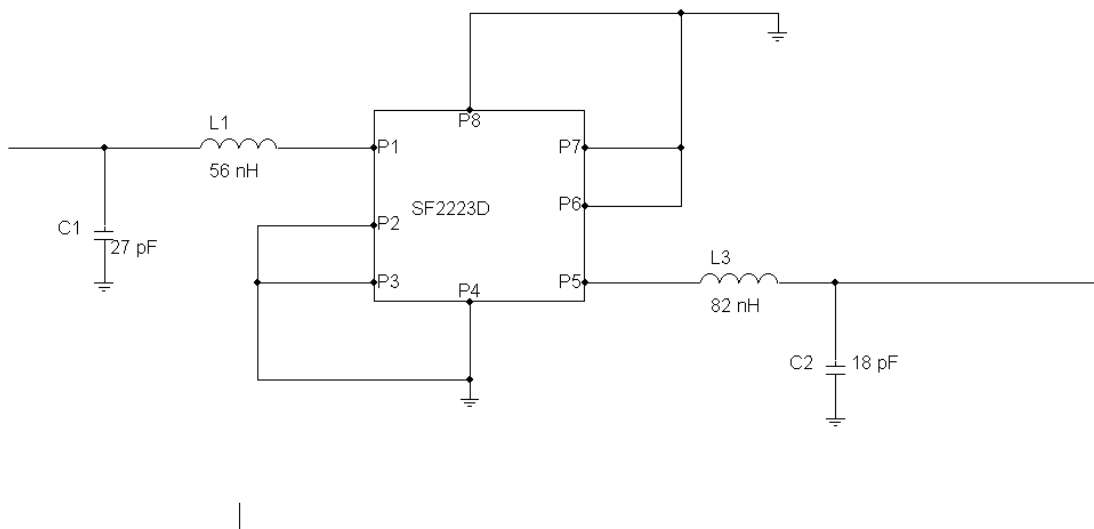

# SM3838-8 Case

## 8-Terminal Ceramic Surface-Mount Case 3.8 X 3.8 mm Nominal Footprint

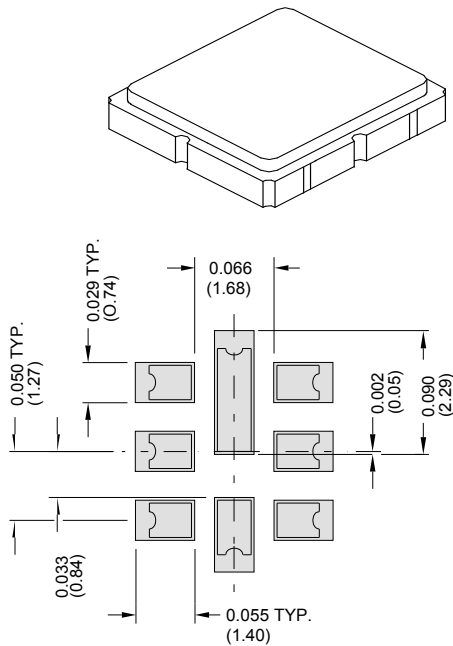

PCB Footprint

### Case Dimensions

Dimension	mm			Inches		
	Min	Nom	Max	Min	Nom	Max
A	3.6	3.8	4.0	0.142	0.150	0.157
B	3.6	3.8	4.0	0.142	0.150	0.157
C	1.05	1.20	1.35	0.041	0.047	0.053
D	0.95	1.10	1.25	0.037	0.043	0.049
E	0.90	1.00	1.10	0.035	0.040	0.043
F	0.50	0.60	0.70	0.020	0.024	0.028
G	2.39	2.54	2.69	0.090	0.100	0.110
H	1.40	1.75	2.05	0.055	0.069	0.080

### Electrical Connections

	Connection	Terminals
Port 1	Balanced Input	1,2
Port 2	Single-ended Output	5
	Ground	All Others

Dot Indicates Pin 1

### Materials

Solder Pad Plating	0.3 to 1.0 $\mu\text{m}$ Gold over 1.27 to 8.89 $\mu\text{m}$ Nickel
Lid Plating	2.0 to 3.0 $\mu\text{m}$ Nickel
Body	$\text{Al}_2\text{O}_3$ Ceramic
Pb Free	

### TOP VIEW

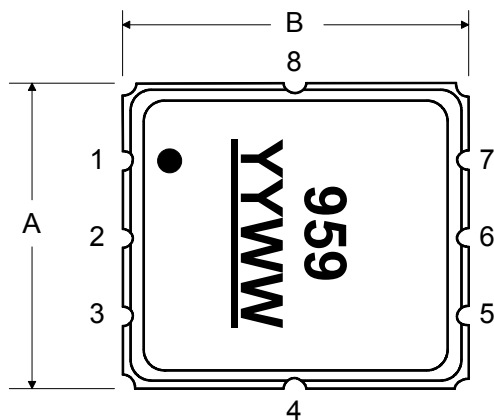

### BOTTOM VIEW

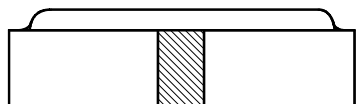
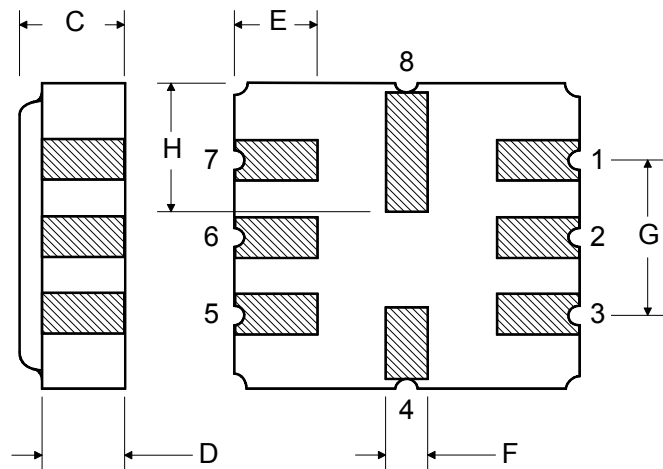

## Tape and Reel Specifications

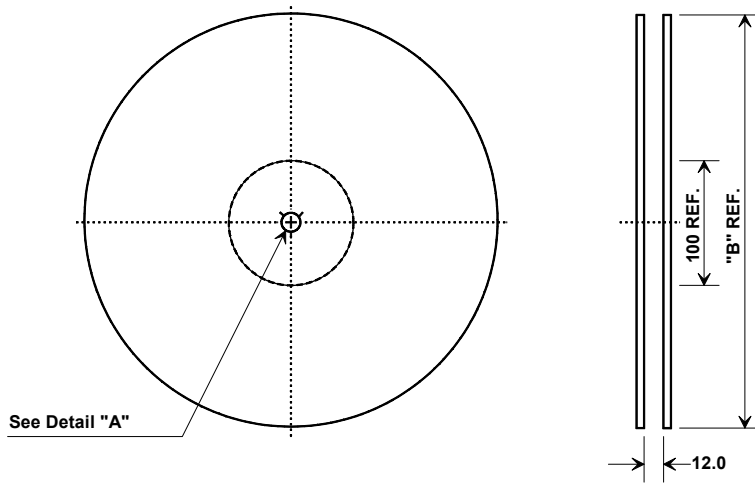

"B" Nominal Size		Quantity Per Reel
Inches	millimeters	
7	178	500
13	330	3000

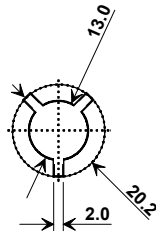

### COMPONENT ORIENTATION and DIMENSIONS

Carrier Tape Dimensions	
Ao	4.25 mm
Bo	4.25 mm
Ko	1.30 mm
Pitch	8.0 mm
W	12.0 mm

