

Doc. Number :

- Tentative Specification
- Preliminary Specification
- Approval Specification

MODEL NO.: G200HJJ
SUFFIX: EN1

Customer:	
APPROVED BY	SIGNATURE
Name / Title _____	_____
Note	

Please return 1 copy for your confirmation with your signature and comments.	

Approved By	Checked By	Prepared By
陳立錚	林秋森	許秣茵

CONTENTS

1. GENERAL DESCRIPTION	5
1.1 OVERVIEW	5
1.2 FEATURE	5
1.3 APPLICATION	5
1.4 GENERAL SPECIFICATIONS	5
1.5 MECHANICAL SPECIFICATIONS	5
2. ABSOLUTE MAXIMUM RATINGS	6
2.1 ABSOLUTE RATINGS OF ENVIRONMENT	6
2.2 ELECTRICAL ABSOLUTE RATINGS	7
2.2.1 TFT LCD MODULE	7
2.2.2 BACKLIGHT UNIT	7
3. ELECTRICAL CHARACTERISTICS	8
3.1 TFT LCD MODULE	8
3.2 INPUT TERMINAL PIN ASSIGNMENT	9
3.3 ELECTRICAL CHARACTERISTICS	10
3.3.1 TFT LCD MODULE	10
3.3.2 BACKLIGHT UNIT	12
3.4 DISPLAY PORT INPUT SIGNAL TIMING SPECIFICATIONS	13
3.4.1 ELECTRICAL SPECIFICATIONS	13
3.4.2 COLOR DATA INPUT ASSIGNMENT	14
3.5 INTERFACE TIMING	15
3.6 POWER ON/OFF SEQUENCE	16
4. OPTICAL CHARACTERISTICS	18
4.1 TEST CONDITIONS	18
4.2 OPTICAL SPECIFICATIONS	18
5. RELIABILITY TEST CRITERIA	21
6. PACKAGING	22
6.1 PACKING SPECIFICATIONS	22
6.2 PACKING METHOD	22
6.3 UN-PACKING METHOD	23
7. DEFINITION OF LABELS	24
7.1 INX MODULE LABEL	24
8. PRECAUTIONS	25
8.1 ASSEMBLY AND HANDLING PRECAUTIONS	25
8.2 STORAGE PRECAUTIONS	25
8.3 OTHER PRECAUTIONS	26

9.MECHANICAL CHARACTERISTICS.....27

REVISION HISTORY

Version	Date	Page	Description
2.0	Apr. 12, 2021	All	Spec Ver.2.0 was first issued.

1. GENERAL DESCRIPTION

1.1 OVERVIEW

G200HJJ-EN1 is a 19.53" TFT Liquid Crystal Display IAV module with LED Backlight units and 30 pins eDP interface. This module supports 1920x1080 FHD mode and can display 16.7M colors.

The PSWG is to establish a set of displays with standard mechanical dimensions and select electrical interface requirements for an industry standard 19.53" FHD LCD panel and the LED driving device for Backlight is built in PCBA.

1.2 FEATURE

- FHD(1920 x1080 pixels) resolution
- PSWG (Panel Standardization Working Group)
- RoHS compliance

1.3 APPLICATION

- TFT LCD Monitor
- Factory Application
- Amusement

1.4 GENERAL SPECIFICATIONS

Item	Specification	Unit	Note
Active Area	434.88(H) x 238.68(V) (19.53" diagonal)	mm	(1)
Bezel Opening Area	438.18(H) x 241.98(V)	mm	
Driver Element	a-Si TFT active matrix	-	-
Pixel Number	1920x R.G.B x 1080	pixel	-
Pixel Pitch	0.2265 (H) x 0.221 (V)	mm	-
Pixel Arrangement	RGB vertical Stripe	-	-
Display Colors	16,777,216	color	-
Display Mode	Normally Black	-	-
Surface Treatment	Hard Coating (3H), Anti-Glare	-	-
Module Power Consumption	Total 18.2 W, @ cell 4 W (Typ.), BL 14.2W(Typ.)	W	Typ.

1.5 MECHANICAL SPECIFICATIONS

Item	Min.	Typ.	Max.	Unit	Note	
Module Size	Horizontal(H)	458.5	459	459.5	mm	(1)
	Vertical(V)	262.5	263.0	263.5	mm	
	Depth(D)	11.82	12.32	12.82	mm	(1)(2)
Bezel Area	Horizontal	437.68	438.18	438.68	mm	-
	Vertical	241.48	241.98	242.48	mm	-
Active Area	Horizontal	-	434.88	-	mm	-
	Vertical	-	238.68	-	mm	-
Weight	1580	1655	1730	g	-	

Note (1) Please refer to the attached drawings for more information of front and back outline dimensions.

Note (2) The depth is without connector.

2. ABSOLUTE MAXIMUM RATINGS

2.1 ABSOLUTE RATINGS OF ENVIRONMENT

Item	Symbol	Value		Unit	Note
		Min.	Max.		
Operating Ambient Temperature	TOP	0	50	°C	(1)(2)
Storage Temperature	TST	-20	60	°C	

Note (1)

- (a) 90 %RH Max.
- (b) Wet-bulb temperature should be 39 °C Max.
- (c) No condensation.

Note (2) Panel surface temperature should be 0°C min. and 65°C max under Vcc=5.0V, fr =60Hz, typical LED string current, 25°C ambient temperature, and no humidity control . Any condition of ambient operating temperature ,the surface of active area should be keeping not higher than 65°C.

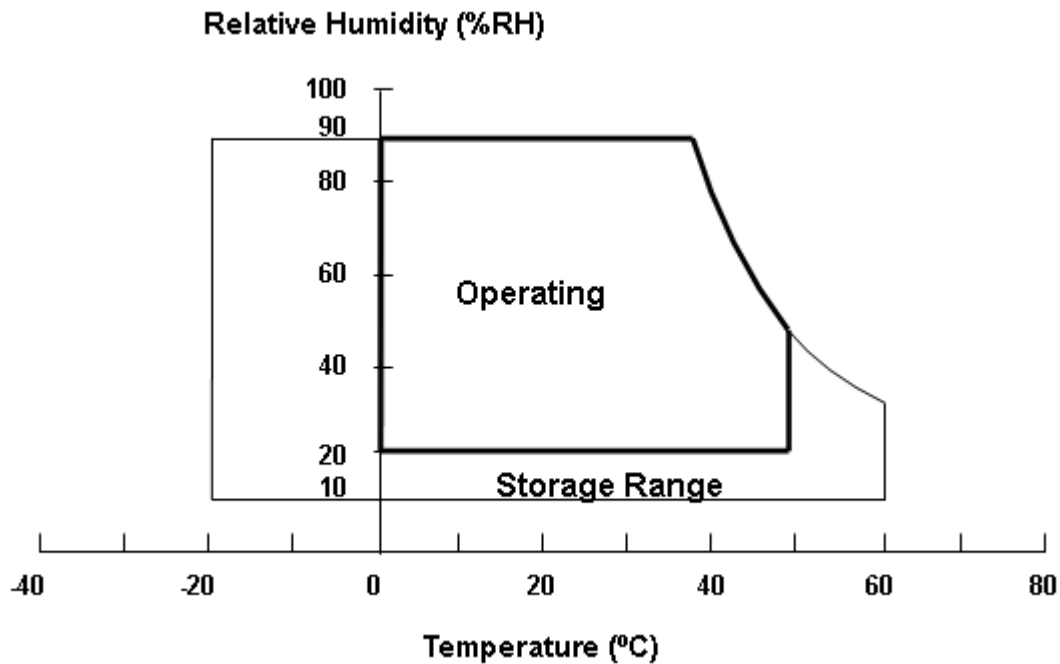

2.2 ELECTRICAL ABSOLUTE RATINGS

2.2.1 TFT LCD MODULE

Item	Symbol	Value		Unit	Note
		Min.	Max.		
Power Supply Voltage	VCC	-0.3	6.0	V	(1)
Logic Input Voltage	V _{IN}	-0.3	3.6	V	

2.2.2 BACKLIGHT UNIT

Item	Symbol	Value		Unit	Note
		Min.	Max.		
Converter Voltage	V _i	-0.3	22.0	V	(1) , (2)
Enable Voltage	EN	---	5.5	V	
Backlight Adjust	Dimming	---	5.5	V	

Note (1) Permanent damage to the device may occur if maximum values are exceeded. Function operation should be restricted to the conditions described under Normal Operating Conditions.

Note (2) Specified values are for lamp (Refer to 3.3.2 for further information).

3. ELECTRICAL CHARACTERISTICS

3.1 TFT LCD MODULE

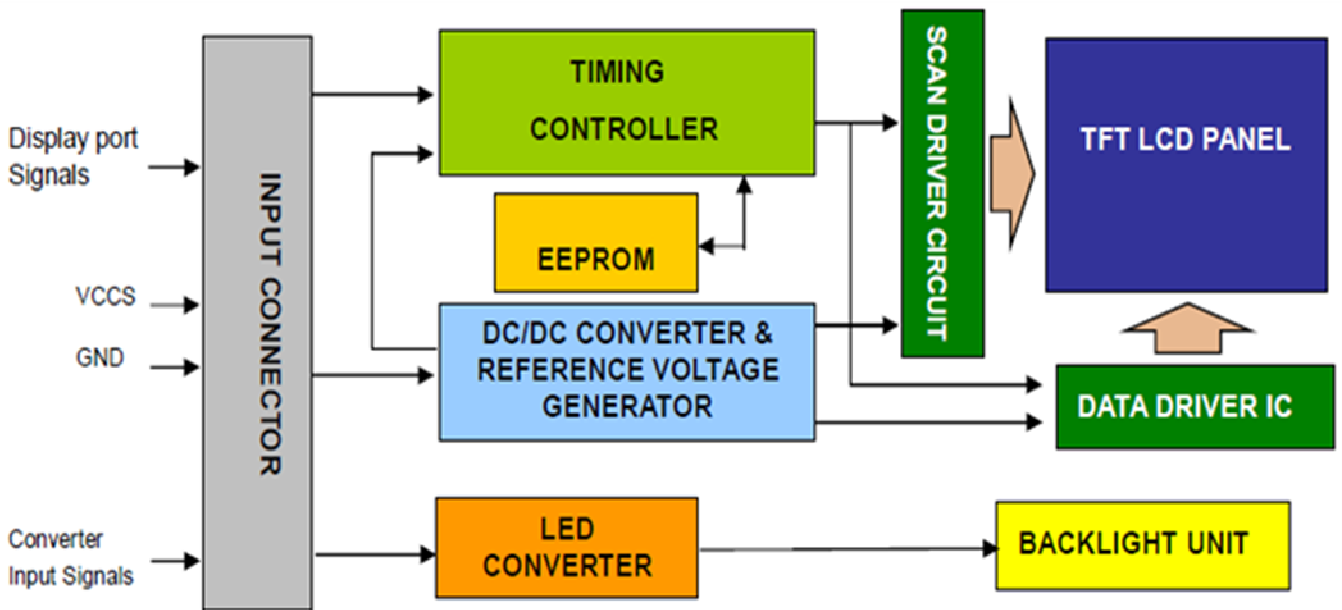

Fig. 3-1 Module Function Block Diagram

3.2 INPUT TERMINAL PIN ASSIGNMENT

PIN ASSIGNMENT

Pin No.	Symbol	Function	Polarity	Note
1	NC	No Connection (Reserved for LCD test)		
2	H_GND	High Speed Ground		
3	ML1-	Complement Signal-Lane 1		
4	ML1+	True Signal-Main Lane 1		
5	H_GND	High Speed Ground		
6	ML0-	Complement Signal-Lane 0		
7	ML0+	True Signal-Main Lane 0		
8	H_GND	High Speed Ground		
9	AUX+	True Signal-Auxiliary Channel		
10	AUX-	Complement Signal-Auxiliary Channel		
11	H_GND	High Speed Ground		
12	VCCS	Power Supply +5 V (typical)		
13	VCCS	Power Supply +5 V (typical)		
14	NC	No Connection (Reserved for LCD test)		
15	GND	Ground		
16	GND	Ground		
17	HPD	Hot Plug Detect		
18	BL_GND	BL Ground		
19	BL_GND	BL Ground		
20	BL_GND	BL Ground		
21	BL_GND	BL Ground		
22	LED_EN	BL_Enable Signal of LED Converter		
23	LED_PWM	PWM Dimming Control Signal of LED Converter		
24	NC	For LCD internal use only		
25	NC	For LCD internal use only		
26	LED_VCCS	BL Power +12.0V (typical)		
27	LED_VCCS	BL Power +12.0V (typical)		
28	LED_VCCS	BL Power +12.0V (typical)		
29	LED_VCCS	BL Power +12.0V (typical)		
30	NC	No Connection(Reserved LCD test)		

Note (1) Connector Part No.: I-PEX 20455-030E-76 or equivalent.

Note (2) User's connector Part No.: I-PEX 20453-030T-03 or equivalent.

Note (3) LED_EN(BLON), LED_PWM(E_PWM) as shown below :

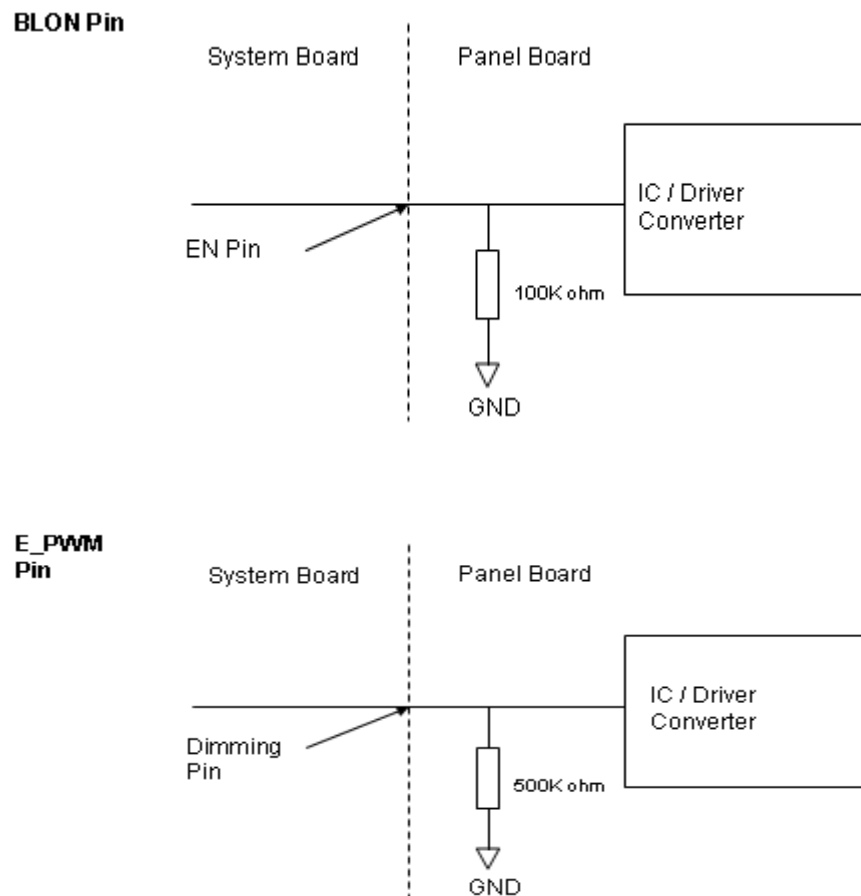

3.3 ELECTRICAL CHARACTERISTICS

3.3.1 TFT LCD MODULE

Parameter	Symbol	Value			Unit	Note	
		Min.	Typ.	Max.			
Power Supply Voltage	V_{CC}	4.5	5	5.5	V	-	
Ripple Voltage	V_{RP}	-	-	300	mVp-p		
Rush Current	I_{RUSH}	-	-	2.5	A	(2)	
Power Supply Current	White	icc	-	580	720	mA	(3)a
	Black		-	600	720	mA	(3)b
HPD Impedance	V_{HPD}	30K			ohm		
HPD	High Level	V_{IH}	2.25	-	3.6	V	-
	Low Level	V_{IL}	0	-	0.4	V	-

Note (1) The module should be always operated within above ranges.

Note (2) Measurement Conditions:

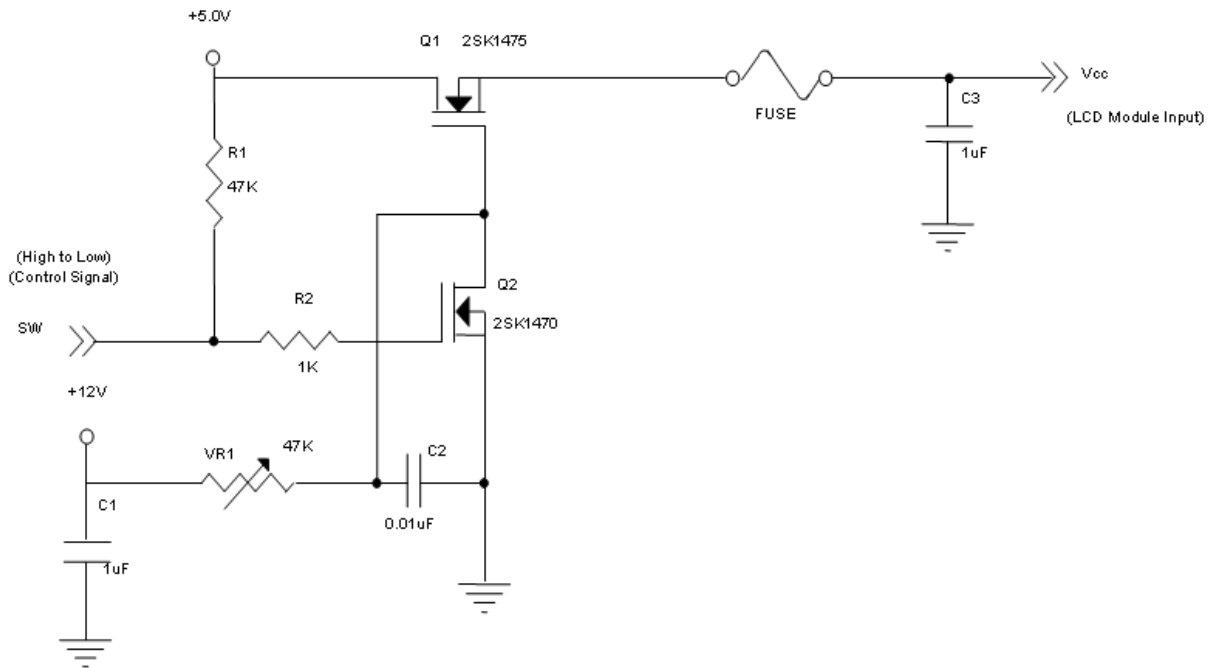

Vcc rising time is 470μs

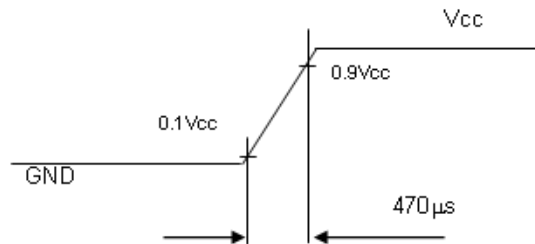

Note (3) The specified power supply current is under the conditions at VDD = 5V, Ta = 25 ± 2 °C, DC Current and fv = 60 Hz, whereas a power dissipation check pattern below is displayed.

a. White Pattern



Active Area

b. Black Pattern

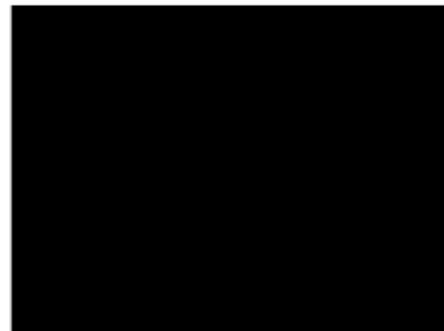

Active Area

3.3.2 BACKLIGHT UNIT

Ta = 25 ± 2 °C

Parameter	Symbol	Value			Unit	Note
		Min.	Typ.	Max.		
Converter Power Supply Voltage	Vi	(10.8)	(12.0)	20.0	V	
Converter Input Ripple voltage	ViRP	-	-	500	mV	(Duty 100%)
Converter Power Supply Current	Ii	---	(1.18)	(1.26)	A	@ Vi = 12V (Duty 100%)
Rush Current	IRUSH	-	-	3.0	A	@ Vi rising time=20ms (Vi=+12.0V)
Backlight Power Consumption	PBL	---	(14.2)	(15.2)	W	@ Vi = 12V (Duty 100%)
EN Control Level	Backlight on	-	2.5	3.3	5.0	V
	Backlight off	-	0	0	0.2	V
PWM Control Level	PWM High Level	-	2.5	3.3	5.0	V
	PWM Low Level	-	0	0	0.2	V
PWM Control Frequency	fPWM	190	200	20k	Hz	(2)
PWM Noise Range	VNoise	-	-	0.1	V	
PWM Control Duty Ratio	-	5		100	%	(1), Suggestion @ 190Hz ≤ fPWM < 1kHz
		20		100	%	(1), @ 1kHz ≤ fPWM ≤ 20kHz
LED Life Time	LLED	50,000			Hrs	(3)

Note (1) LED current is measured by utilizing a high frequency current meter as shown below:

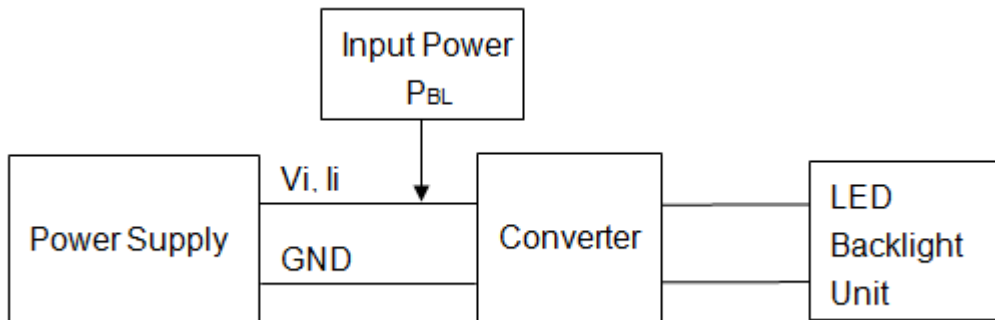

Note (2) At 190 ~1kHz PWM control frequency, duty ratio range is restricted from 5% to 100%.

1K ~20kHz PWM control frequency, duty ratio range is restricted from 20% to 100%.

If PWM control frequency is applied in the range from 1KHz to 20KHZ, The “non-linear” phenomenon

on the Backlight Unit may be found. So It's a suggestion that PWM control frequency should be less than 1KHz.

Note (3) The lifetime of LED is estimated data and defined as the time when it continues to operate under the conditions at Ta = 25 ±2 °C until the brightness becomes ≤ 50% of its original value.

Operating LED under high temperature environment will reduce life time and lead to color shift.

3.4 DISPLAY PORT INPUT SIGNAL TIMING SPECIFICATIONS

3.4.1 ELECTRICAL SPECIFICATIONS

Parameter	Symbol	Min.	Typ.	Max.	Unit	Notes
Differential Signal Common Mode Voltage(MainLink and AUX)	VCM	0		2	V	(1)(4)
AUX AC Coupling Capacitor	C_Aux_Source	75		200	nF	(2)
Main Link AC Coupling Capacitor	C_ML_Source	75		200	nF	(3)

Note (1) Display port interface related AC coupled signals should follow VESA DisplayPort Standard Version1. Revision 1a and VESA Embedded DisplayPort™ Standard Version 1.2. There are many optional items described in eDP1.2. If some optional item is requested, please contact us.

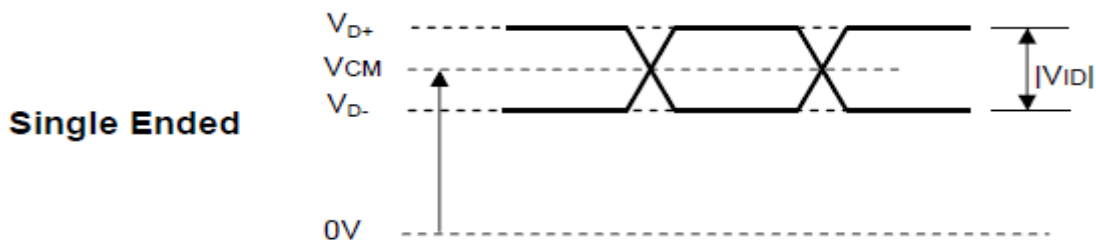

Note (2) Recommended eDP AUX Channel topology is as below and the AUX AC Coupling Capacitor (C_Aux_Source) should be placed on the source device.

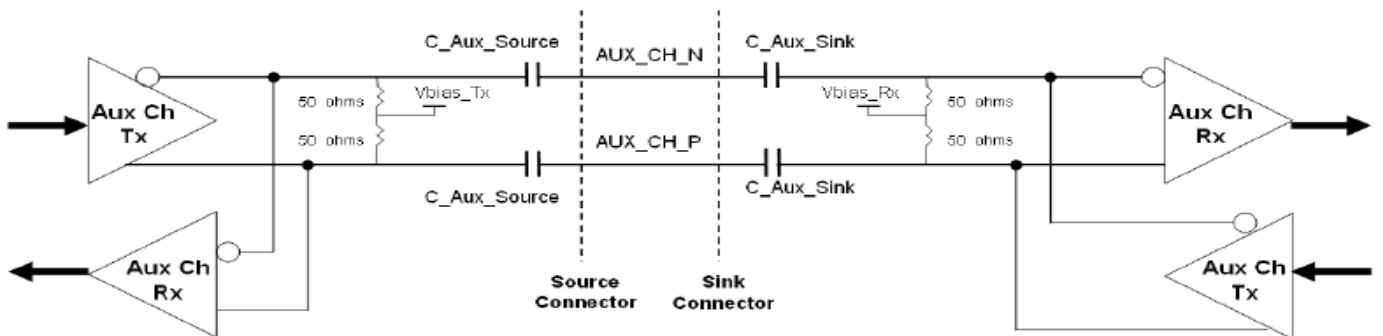

Note (3) Recommended Main Link Channel topology is as below and the Main Link AC Coupling Capacitor (C_ML_Source) should be placed on the source device.

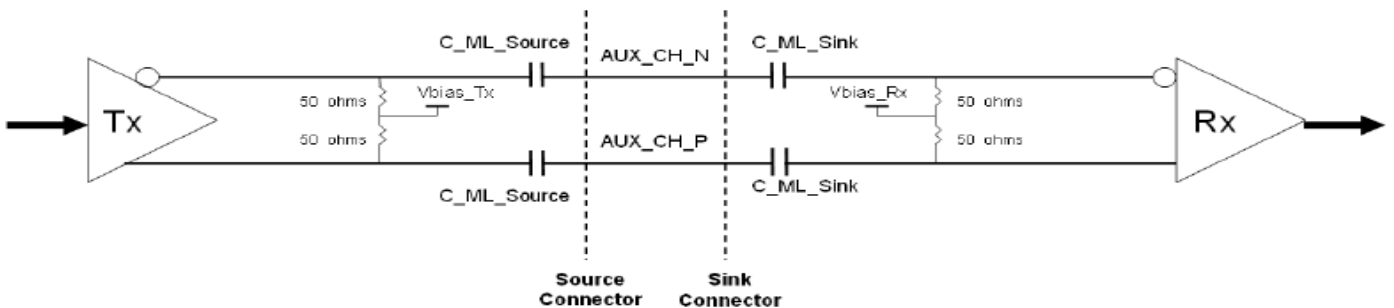

Note (4) The source device should pass the test criteria described in DisplayPortCompliance Test Specification(CTS) 1.1

3.4.2 COLOR DATA INPUT ASSIGNMENT

The brightness of each primary color (red, green and blue) is based on the 8-bit gray scale data input for the color. The higher the binary input the brighter the color. The table below provides the assignment of color versus data input.

Color		Data Signal																							
		Red								Green								Blue							
		R7	R6	R5	R4	R3	R2	R1	R0	G7	G6	G5	G4	G3	G2	G1	G0	B7	B6	B5	B4	B3	B2	B1	B0
Basic Colors	Black	0	0	0	0	0	0	0	0	0	0	0	0	0	0	0	0	0	0	0	0	0	0	0	0
	Red	1	1	1	1	1	1	1	1	0	0	0	0	0	0	0	0	0	0	0	0	0	0	0	0
	Green	0	0	0	0	0	0	0	0	1	1	1	1	1	1	1	1	0	0	0	0	0	0	0	0
	Blue	0	0	0	0	0	0	0	0	0	0	0	0	0	0	0	1	1	1	1	1	1	1	1	1
	Cyan	0	0	0	0	0	0	0	0	1	1	1	1	1	1	1	1	1	1	1	1	1	1	1	1
	Magenta	1	1	1	1	1	1	1	1	0	0	0	0	0	0	0	0	1	1	1	1	1	1	1	1
	Yellow	1	1	1	1	1	1	1	1	1	1	1	1	1	1	1	1	0	0	0	0	0	0	0	0
	White	1	1	1	1	1	1	1	1	1	1	1	1	1	1	1	1	1	1	1	1	1	1	1	1
Gray Scale Of Red	Red(0) / Dark	0	0	0	0	0	0	0	0	0	0	0	0	0	0	0	0	0	0	0	0	0	0	0	
	Red(1)	0	0	0	0	0	0	0	1	0	0	0	0	0	0	0	0	0	0	0	0	0	0	0	
	Red(2)	0	0	0	0	0	0	1	0	0	0	0	0	0	0	0	0	0	0	0	0	0	0	0	
	⋮	⋮	⋮	⋮	⋮	⋮	⋮	⋮	⋮	⋮	⋮	⋮	⋮	⋮	⋮	⋮	⋮	⋮	⋮	⋮	⋮	⋮	⋮	⋮	
	⋮	⋮	⋮	⋮	⋮	⋮	⋮	⋮	⋮	⋮	⋮	⋮	⋮	⋮	⋮	⋮	⋮	⋮	⋮	⋮	⋮	⋮	⋮	⋮	
	Red(253)	1	1	1	1	1	1	0	1	0	0	0	0	0	0	0	0	0	0	0	0	0	0	0	
	Red(254)	1	1	1	1	1	1	1	0	0	0	0	0	0	0	0	0	0	0	0	0	0	0	0	
	Red(255)	1	1	1	1	1	1	1	1	0	0	0	0	0	0	0	0	0	0	0	0	0	0	0	
Gray Scale Of Green	Green(0)/Dark	0	0	0	0	0	0	0	0	0	0	0	0	0	0	0	0	0	0	0	0	0	0	0	
	Green(1)	0	0	0	0	0	0	0	0	0	0	0	0	0	0	1	0	0	0	0	0	0	0	0	
	Green(2)	0	0	0	0	0	0	0	0	0	0	0	0	0	1	0	0	0	0	0	0	0	0	0	
	⋮	⋮	⋮	⋮	⋮	⋮	⋮	⋮	⋮	⋮	⋮	⋮	⋮	⋮	⋮	⋮	⋮	⋮	⋮	⋮	⋮	⋮	⋮	⋮	
	⋮	⋮	⋮	⋮	⋮	⋮	⋮	⋮	⋮	⋮	⋮	⋮	⋮	⋮	⋮	⋮	⋮	⋮	⋮	⋮	⋮	⋮	⋮	⋮	
	Green(253)	0	0	0	0	0	0	0	0	1	1	1	1	1	1	0	1	0	0	0	0	0	0	0	
	Green(254)	0	0	0	0	0	0	0	0	1	1	1	1	1	1	1	0	0	0	0	0	0	0	0	
	Green(255)	0	0	0	0	0	0	0	0	1	1	1	1	1	1	1	1	0	0	0	0	0	0	0	
Gray Scale Of Blue	Blue(0) / Dark	0	0	0	0	0	0	0	0	0	0	0	0	0	0	0	0	0	0	0	0	0	0	0	
	Blue(1)	0	0	0	0	0	0	0	0	0	0	0	0	0	0	0	0	0	0	0	0	0	0	1	
	Blue(2)	0	0	0	0	0	0	0	0	0	0	0	0	0	0	0	0	0	0	0	0	0	1	0	
	⋮	⋮	⋮	⋮	⋮	⋮	⋮	⋮	⋮	⋮	⋮	⋮	⋮	⋮	⋮	⋮	⋮	⋮	⋮	⋮	⋮	⋮	⋮	⋮	
	⋮	⋮	⋮	⋮	⋮	⋮	⋮	⋮	⋮	⋮	⋮	⋮	⋮	⋮	⋮	⋮	⋮	⋮	⋮	⋮	⋮	⋮	⋮	⋮	
	Blue(253)	0	0	0	0	0	0	0	0	0	0	0	0	0	0	0	1	1	1	1	1	1	1	0	
	Blue(254)	0	0	0	0	0	0	0	0	0	0	0	0	0	0	0	1	1	1	1	1	1	1	0	
	Blue(255)	0	0	0	0	0	0	0	0	0	0	0	0	0	0	0	1	1	1	1	1	1	1	1	

Note (1)0: Low Level Voltage, 1: High Level Voltage

3.5 INTERFACE TIMING

INPUT SIGNAL TIMING SPECIFICATIONS

The input signal timing specifications are shown as the following table and timing diagram.

Signal	Item	Symbol	Min.	Typ.	Max.	Unit	Note
Frame rate	Frequency	Fr	-	60	-	Hz	-
DCLK	Clock frequency	Fc	90	151.8	170	MHz	-
Vertical Display Term	Total	Tv	1092	1125	2280	Th	-
	Active Display	Tvd	-	1080	-	Th	-
	Blank	Tvb	Tv-Tvd	45	Tv-Tvd	Th	-
Horizontal Display Term	Total	Th	2040	2250	2520	Tc	Th=Thd+Thb
	Active Display	Thd	-	1920	-	Tc	-
	Blank	Thb	Th-Thd	330	Th-Thd	Tc	-

Note (1) Because this module is operated by DE only mode, Hsync and Vsync input signals should be set to low logic level or ground. Otherwise, this module would operate abnormally.

Note (2) The $T_v(T_{vd}+T_{vb})$ must be integer, otherwise, the module would operate abnormally.

Note (3) The maximum clock frequency = $T_v * T_h * 60 < 170$ MHz.

INPUT SIGNAL TIMING DIAGRAM

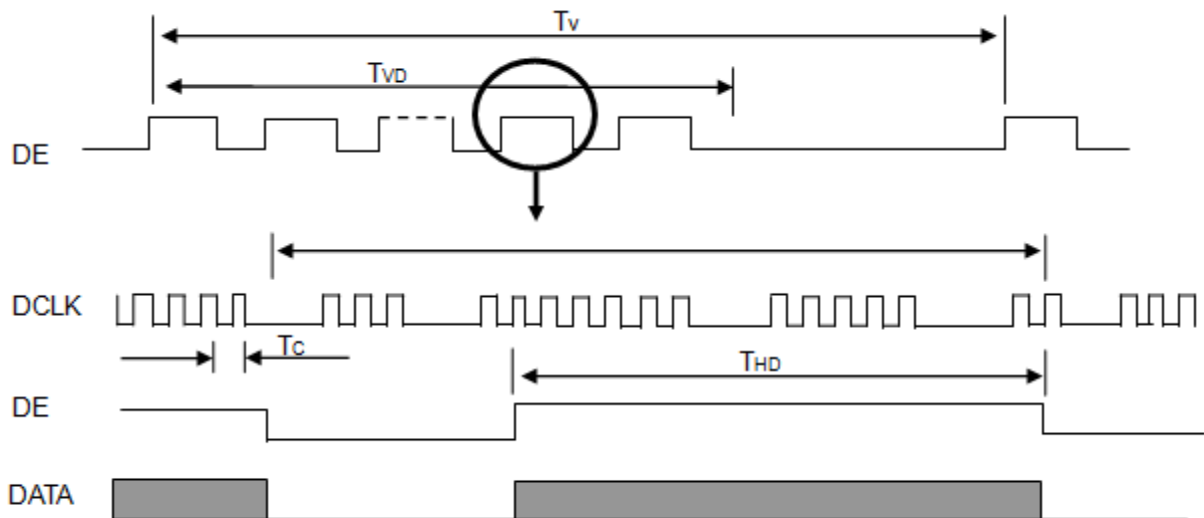

3.6 POWER ON/OFF SEQUENCE

To prevent a latch-up or DC operation of LCD assembly, the power on/off sequence should be as the diagram below.

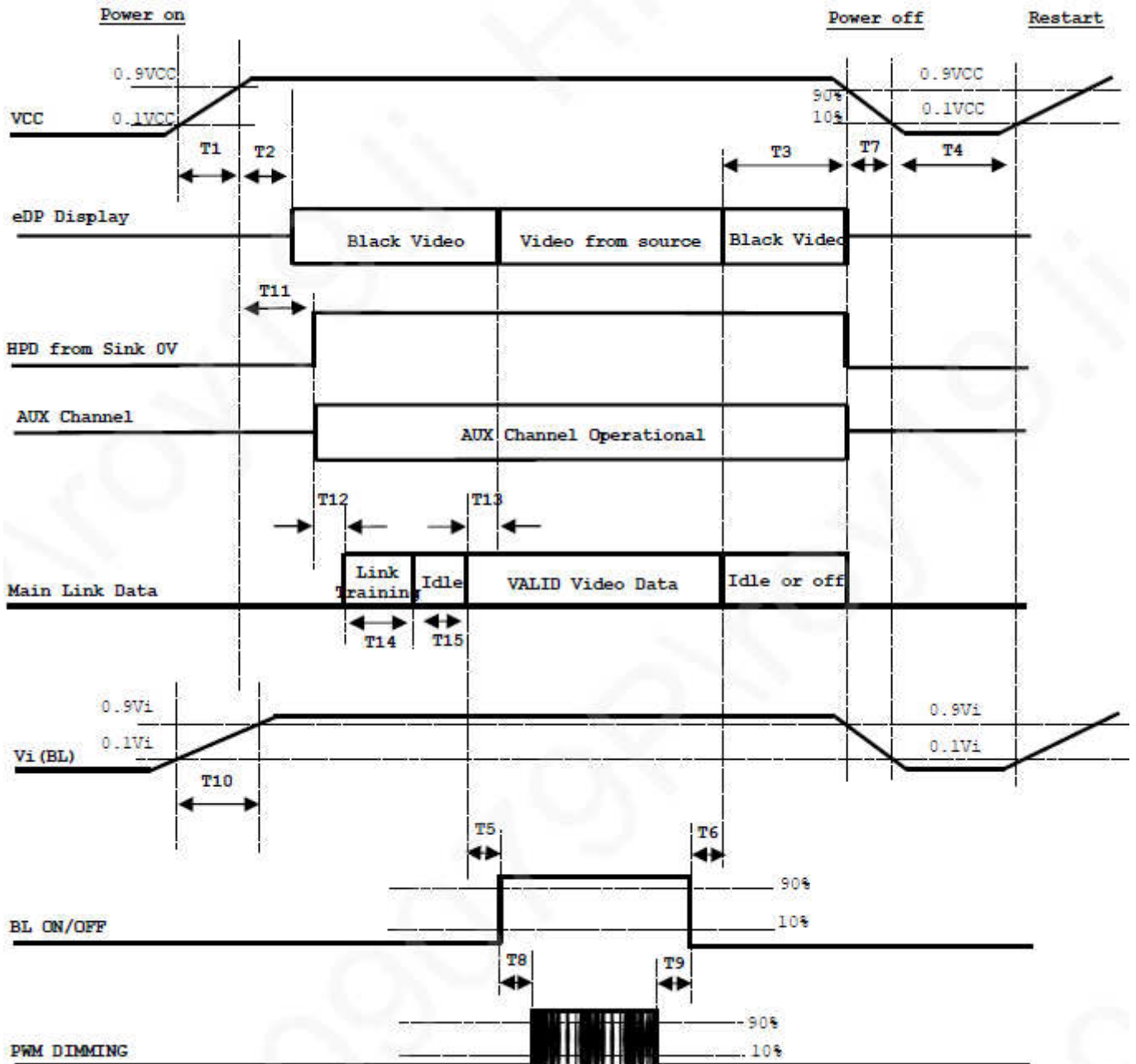

Timing Specification

Parameter	Value			Units
	Min.	Typ.	Max.	
T1	0.5	-	10	ms
T2(2)(3)	0	-	200	ms
T3	0	-	500	ms
T4	500	-	-	ms
T5	450	-	-	ms
T6(2)(3)	200	-	-	ms
T7	0.5	-	10	ms
T8	10	-	-	ms
T9	10	-	-	ms
T10	0.5	-	10	ms
T11(4)	0	-	200	ms
T12	0	-	-	ms
T13	0	-	50	ms
T14	0	-	-	ms
T15	0	-	-	ms

Note(1) Please don't plug or unplug the interface cable when system is turned on.

Note(2) The Sink must include the ability to automatically generate Black Video autonomously. The Sink must automatically enable Black Video under the following conditions: Upon LCDVCC power on (within T2 max), When the "NoVideoStream_Flag" (VB-ID Bit 3) is received from the Source (at the end of T6)

Note(3) The Sink may implement the ability to disable the automatic Black Video function, as described in Note (2), above, for system development and debugging purposes.

Note(4) The Sink must support AUX Channel polling by the Source immediately following LCDVCC power-on without causing damage to the Sink device (the Source can re-try if the Sink is not ready). The Sink must be able to response to an AUX Channel transaction with the time specified within T11 max.

4. OPTICAL CHARACTERISTICS

4.1 TEST CONDITIONS

Item	Symbol	Value	Unit
Ambient Temperature	Ta	25±2	oC
Ambient Humidity	Ha	50±10	%RH
Supply Voltage	According to typical value and tolerance in "ELECTRICAL CHARACTERISTICS"		
Input Signal			
PWM Duty Ratio	D	100	%

4.2 OPTICAL SPECIFICATIONS

The relative measurement methods of optical characteristics are shown here and all items are measured at the center point of screen unless otherwise noted. The following items should be measured under the test conditions described above and stable conditions shown in Note (5).

Item	Symbol	Condition	Min.	Typ.	Max.	Unit	Note	
Color Chromaticity	Red	Rx	Typ - 0.05	0.644	Typ + 0.05	-	(1), (5)	
		Ry		0.338				
	Green	Gx		0.316				
		Gy		0.616				
	Blue	Bx		0.150				
		By		0.056				
	White	Wx		0.313				
		Wy		0.329				
Center Luminance of White	LC	$\theta X=0^\circ, \theta Y=0^\circ$ Grayscale Maximum	280	350		cd/m ²	(4), (5)	
Contrast Ratio	CR		2000	3000		-	(2), (5)	
Response Time	TR		$\theta X=0^\circ, \theta Y=0^\circ$	-	15	20	ms	(3)
	TF	-		5	10	ms		
White Variation	δW	$\theta X=0^\circ, \theta Y=0^\circ$	70	75	-	ms	(5), (6)	
Viewing Angle	Horizontal	$\theta X+$	$CR \geq 10$	80	85	-	Deg.	(1), (5)
		$\theta X-$		80	85	-		
	Vertical	$\theta Y+$		80	85	-		
		$\theta Y-$		80	85	-		

Definition :

Grayscale Maximum : Grayscale 255 (10 bits: grayscale 1023 ; 8 bits : grayscale 255 ; 6 bits: grayscale 63)

White : Luminance of Grayscale Maximum (All R,G,B)

Black : Luminance of grayscale 0 (All R,G,B)

Note (1) Definition of Viewing Angle (θ_x, θ_y):

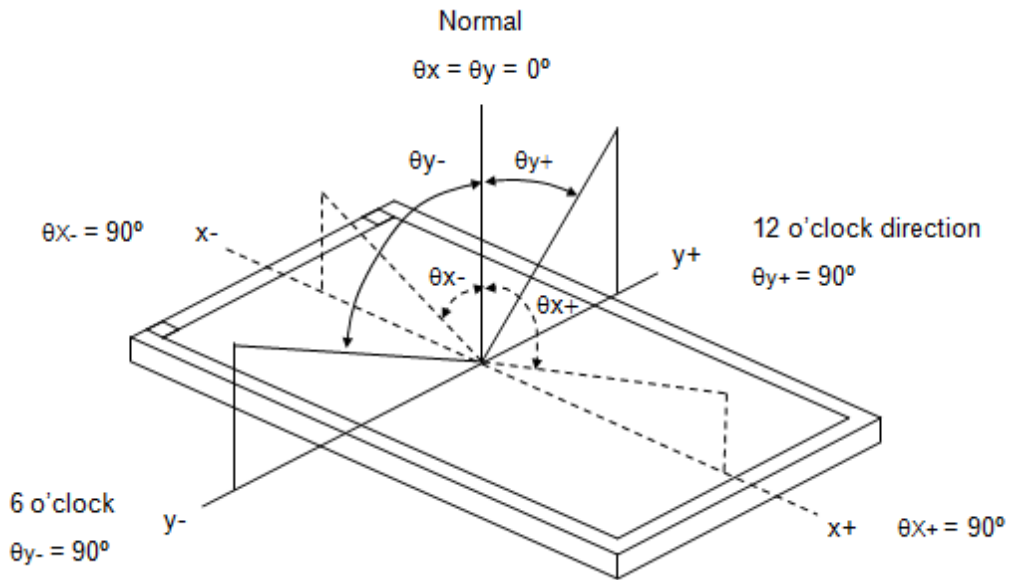

Note (2) Definition of Contrast Ratio (CR):

The contrast ratio can be calculated by the following expression.

$$\text{Contrast Ratio (CR)} = \text{White} / \text{Black}$$

Note (3) Definition of Response Time (T_R, T_F):

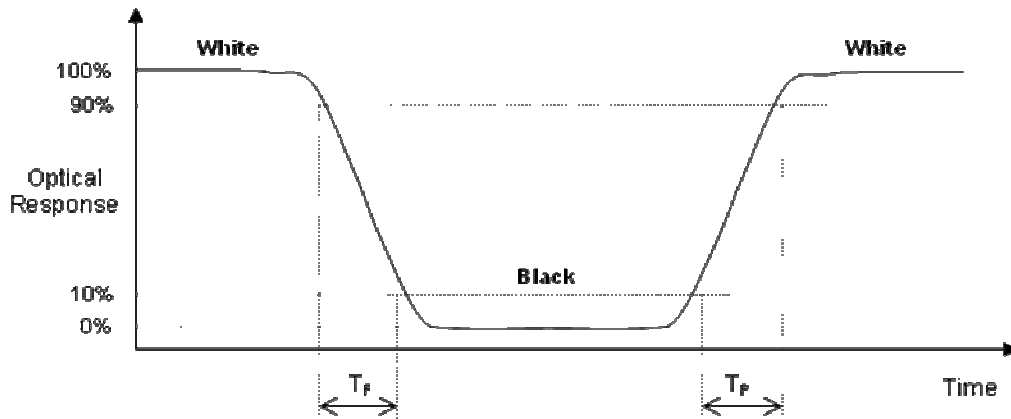

Note (4) Definition of Luminance of White (L_C):

Measure the luminance of White 255 at center point

Note (5) Measurement Setup:

The LCD module should be stabilized at given temperature to avoid abrupt temperature change during measuring. In order to stabilize the luminance, the measurement should be executed after lighting Backlight for 40 minutes in a windless room.

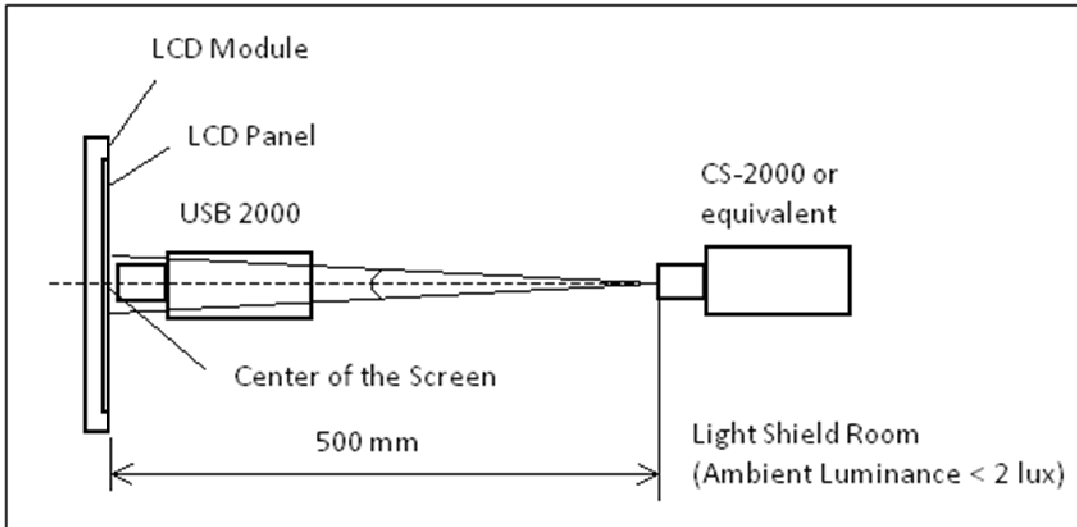

Note (6) Definition of White Variation (δW):

Measure the luminance of White at 9 points.

Luminance of White : $L(X)$, where X is from 1 to 9.

$$\delta W = \frac{\text{Minimum [L(1) to L(9)]}}{\text{Maximum [L(1) to L(9)]}} \times 100\%$$

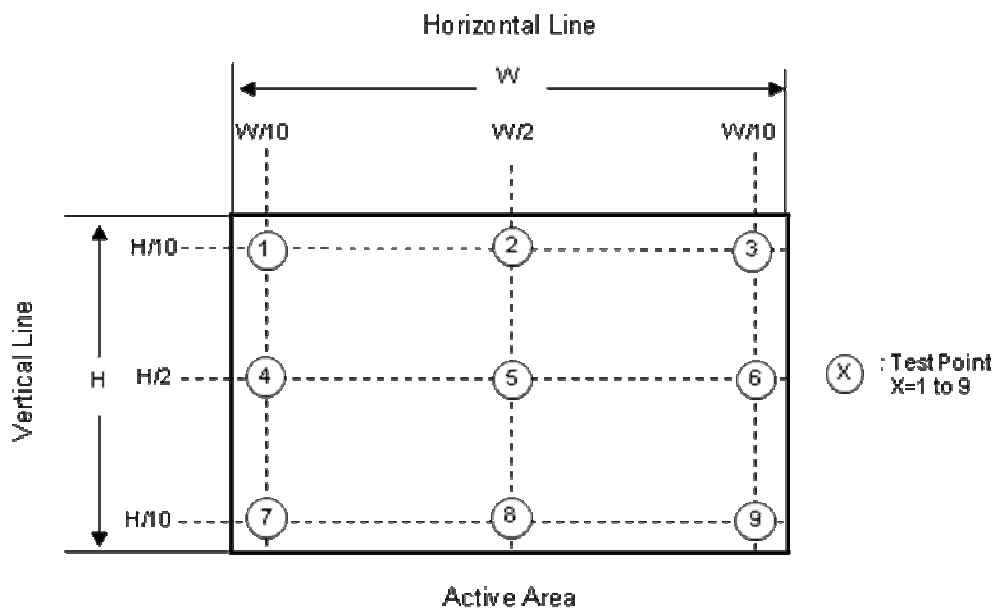

5. RELIABILITY TEST CRITERIA

Test Item	Test Condition	Note
High Temperature Storage Test	60°C, 240 hours	(1),(2) (4),(5)
Low Temperature Storage Test	-20°C, 240 hours	
Thermal Shock Storage Test	-20°C, 0.5 hour ←→ 60°C, 0.5 hour; 100cycles, 1 hour/cycle	
High Temperature Operation Test	50°C, 240 hours	
Low Temperature Operation Test	0°C, 240 hours	
High Temperature & High Humidity Operation Test	50°C, RH 80%, 300 hours	
ESD Test (Operation)	150pF, 330Ω, 1 sec/cycle Condition 1 : panel contact, ±8 KV Condition 2 : panel non-contact ±15 KV	(1), (4)
Shock (Non-Operating)	50G, 11ms, half sine wave, 1 time for ± X, ± Y, ± Z direction	(2), (3)
Vibration (Non-Operating)	1.5G, 10 ~ 300 Hz sine wave, 10 min/cycle, 3 cycles each X, Y, Z direction	

Note (1) There should be no condensation on the surface of panel during test ,

Note (2) Temperature of panel display surface area should be 65°C Max.

Note (3) At testing Vibration and Shock, the fixture in holding the module has to be hard and rigid enough so that the module would not be twisted or bent by the fixture.

Note (4) In the standard conditions, there is no function failure issue occurred. All the cosmetic specification is judged before reliability test.

Note (5) Before cosmetic and function test, the product must have enough recovery time, at least 24 hours at room temperature.

6. PACKAGING

6.1 PACKING SPECIFICATIONS

- (1) 15 LCD modules / 1 Box
- (2) Box dimensions: 540(L)*395(W)*355(H)mm
- (3) Weight: approximately: 26.5kg (15 modules per box)

6.2 PACKING METHOD

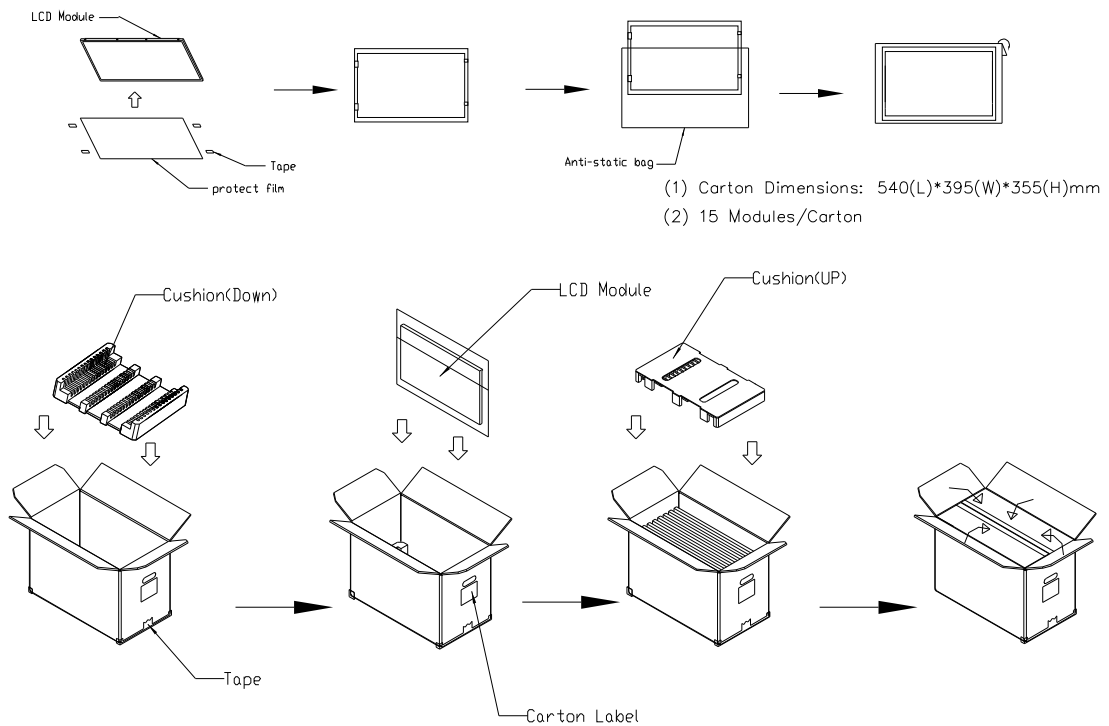
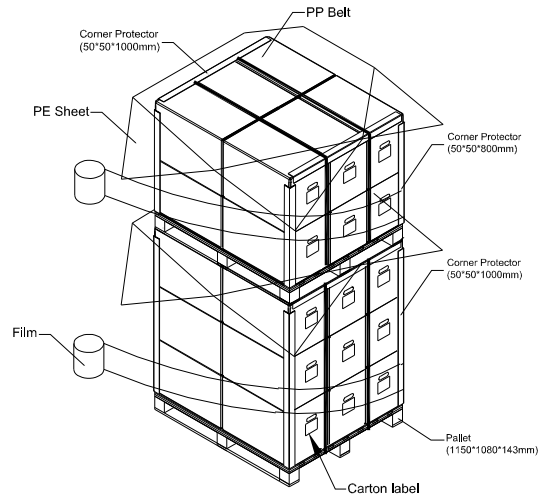
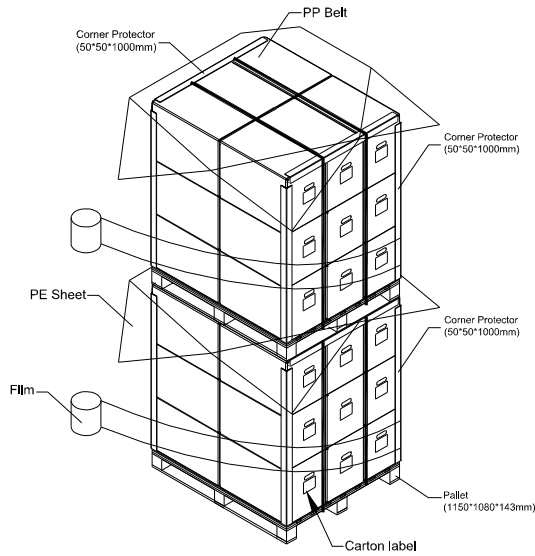

Figure. 6-1 Packing method

For ocean shipping

Sea / Land Transportation (40ft HQ Container)

Sea / Land Transportation (40ft Container)



For air transport

Air Transportation

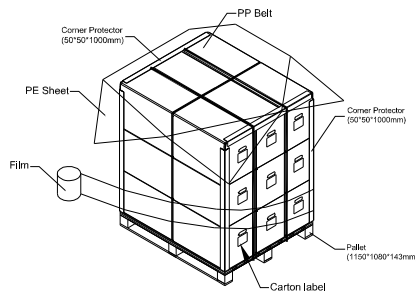

Figure. 6-2 Packing method

6.3 UN-PACKING METHOD

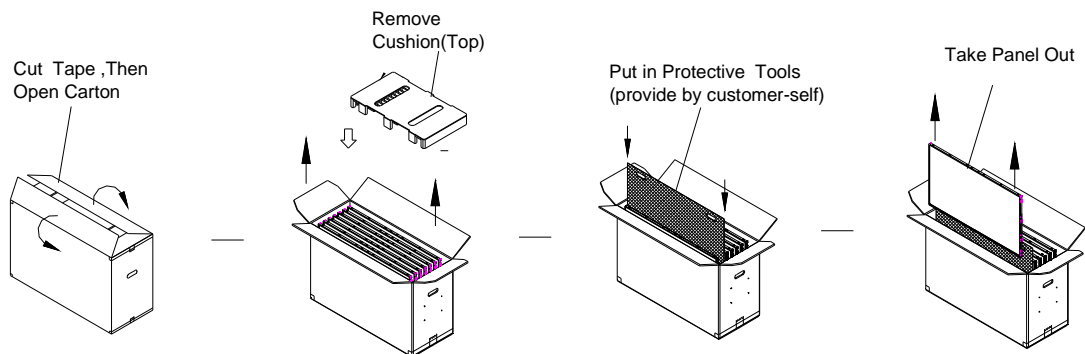

Figure. 6-3 Un-Packing method

7. DEFINITION OF LABELS

7.1 INX MODULE LABEL

The barcode nameplate is pasted on each module as illustration, and its definitions are as following explanation.



Note (1) Safety Compliance(UL logo) will open after C1 version.

(a) Model Name: G200HJJ-EN1

(b) * * * * : Factory ID

(c) Serial ID: X X X X X X Y M D X N N N N

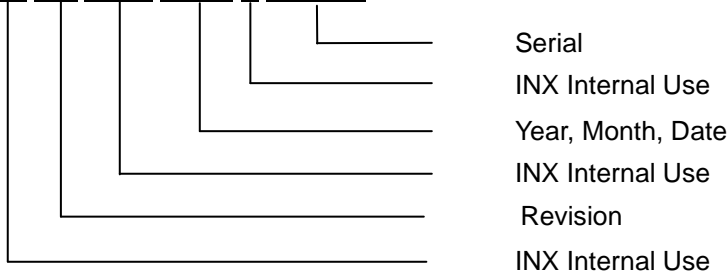

Serial ID includes the information as below:

- (a) Manufactured Date: 1~9, for 2021~2029
 Month: 1~9, A~C, for Jan. ~ Dec.
 Day: 1~9, A~Y, for 1st to 31st, exclude I , O and U
- (b) Revision Code: cover all the change
- (c) Serial No.: Manufacturing sequence of product

8. PRECAUTIONS

8.1 ASSEMBLY AND HANDLING PRECAUTIONS

- (1) The module should be assembled into the system firmly by using every mounting hole. Be careful not to twist or bend the module.
- (2) While assembling or installing modules, it can only be in the clean area. The dust and oil may cause electrical short or damage the polarizer.
- (3) Use fingerstalls or soft gloves in order to keep display clean during the incoming inspection and assembly process.
- (4) Do not press or scratch the surface harder than a HB pencil lead on the panel because the polarizer is very soft and easily scratched.
- (5) If the surface of the polarizer is dirty, please clean it by some absorbent cotton or soft cloth. Do not use Ketone type materials (ex. Acetone), Ethyl alcohol, Toluene, Ethyl acid or Methyl chloride. It might permanently damage the polarizer due to chemical reaction.
- (6) Wipe off water droplets or oil immediately. Staining and discoloration may occur if they left on panel for a long time.
- (7) If the liquid crystal material leaks from the panel, it should be kept away from the eyes or mouth. In case of contacting with hands, legs or clothes, it must be washed away thoroughly with soap.
- (8) Protect the module from static electricity, it may cause damage to the C-MOS Gate Array IC.
- (9) Do not disassemble the module.
- (10) Do not pull or fold the lamp wire.
- (11) Pins of I/F connector should not be touched directly with bare hands.

8.2 STORAGE PRECAUTIONS

- (1) When storing for a long time, the following precautions are necessary.
 - (a) Store them in a dark place. Do not expose the module to sunlight or fluorescent light. Keep the temperature between 5°C and 30°C at humidity 50+-10%RH.
 - (b) The polarizer surface should not come in contact with any other object.
 - (c) It is recommended that they be stored in the container in which they were shipped.
 - (d) Storage condition is guaranteed under packing conditions.
 - (e) The phase transition of Liquid Crystal in the condition of the low or high storage temperature will be recovered when the LCD module returns to the normal condition
- (2) High temperature or humidity may reduce the performance of module. Please store LCD module within the specified storage conditions.
- (3) It is dangerous that moisture come into or contacted the LCD module, because the moisture may damage LCD module when it is operating.
- (4) It may reduce the display quality if the ambient temperature is lower than 10 °C. For example, the response time will become slowly, and the starting voltage of lamp will be higher than the room temperature.

8.3 OTHER PRECAUTIONS

- (1) Normal operating condition
 - (a) Display pattern: dynamic pattern (Real display)
 - (Note) Long-term static display can cause image sticking.
- (2) Operating usages to protect against image sticking due to long-term static display
 - (a) Suitable operating time: under 16 hours a day.
 - (b) Static information display recommended to use with moving image.
 - (c) Cycling display between 5 minutes' information(static) display and 10 seconds' moving image.
- (3) Abnormal condition just means conditions except normal condition.

9. MECHANICAL CHARACTERISTICS

