

( V ) Preliminary Specifications  
 ( ) Final Specifications

<b>Module</b>	10.4 Inch Color TFT-LCD
<b>Model Name</b>	G104VTN01.0

<b>Customer</b>	<b>Date</b>
<b>Checked &amp; Approved by</b>	
_____	_____

Note: This Specification is subject to change without notice.

<b>Approved by</b>	<b>Date</b>
_____ LeaDer Feng	_____ 2022/03/03
<b>Prepared by</b>	
_____ Fanny Lin	_____ 2022/03/03

General Display Business Division /  
 AUO Display Plus Corporation

## Contents

<b>1. Operating Precautions .....</b>	<b>4</b>
<b>2. General Description .....</b>	<b>5</b>
2.1 Display Characteristics .....	5
2.2 Optical Characteristics.....	6
<b>3. Functional Block Diagram .....</b>	<b>9</b>
<b>4. Absolute Maximum Ratings .....</b>	<b>10</b>
4.1 Absolute Ratings of TFT LCD Module .....	10
4.2 Absolute Ratings of Environment.....	10
<b>5. Electrical Characteristics .....</b>	<b>11</b>
5.1 TFT LCD Module .....	11
5.2 Backlight Unit.....	13
<b>6. Signal Characteristics.....</b>	<b>14</b>
6.1 Pixel Format Image .....	14
6.2 TFT-LCD Interface Signal Description.....	15
6.3 The Input Data Format.....	17
6.4 TFT-LCD Interface Timing.....	18
6.5 Power ON/OFF Sequence .....	19
7. Connector & Pin Assignment .....	20
7.1 TFT-LCD Signal (CN1): LCD Connector .....	20
7.2 LED Backlight Unit (CN2): Backlight Connector .....	20
<b>8. Reliability Test Criteria.....</b>	<b>21</b>
<b>9. Mechanical Characteristics .....</b>	<b>22</b>
9.1 LCM Outline Dimension (Front View) .....	22
9.2 LCM Outline Dimension (Rear View) .....	23
<b>10. Label and Packaging.....</b>	<b>24</b>
10.1 Shipping Label (on the rear side of TFT-LCD display) .....	24
10.2 Carton Package .....	24
<b>11 Safety.....</b>	<b>25</b>
11.1 Sharp Edge Requirements .....	25
11.2 Materials .....	25
11.3 Capacitors .....	25
11.4 National Test Lab Requirement.....	25



AUO Display+

G104VTN01.0

Preliminary Spec ver.0.0

### Record of Revision

Version	Date	Page	Old description	New Description
0.0	2022/03/10	All	First edition	

## 1. Operating Precautions

- 1) Since front polarizer is easily damaged, please be cautious and not to scratch it.
- 2) Be sure to turn off power supply when inserting or disconnecting from input connector.
- 3) Wipe off water drop immediately. Long contact with water may cause discoloration or spots.
- 4) When the panel surface is soiled, wipe it with absorbent cotton or soft cloth.
- 5) Since the panel is made of glass, it may be broken or cracked if dropped or bumped on hard surface.
- 6) To avoid ESD (Electro Static Discharge) damage, be sure to ground yourself before handling TFT-LCD Module.
- 7) Do not open nor modify the module assembly.
- 8) Do not press the reflector sheet at the back of the module to any direction.
- 9) In case if a module has to be put back into the packing container slot after it was taken out from the container, do not press the center of the LED light bar edge. Instead, press at the far ends of the LED light bar edge softly. Otherwise the TFT Module may be damaged.
- 10) At the insertion or removal of the Signal Interface Connector, be sure not to rotate nor tilt the Interface Connector of the TFT Module.
- 11) TFT-LCD Module is not allowed to be twisted & bent even force is added on module in a very short time. Please design your display product well to avoid external force applying to module by end-user directly.
- 12) Small amount of materials without flammability grade are used in the TFT-LCD module. The TFT-LCD module should be supplied by power complied with requirements of Limited Power Source (IEC60950 or UL1950), or be applied exemption.
- 13) Severe temperature condition may result in different luminance, response time and lamp ignition voltage.
- 14) Continuous operating TFT-LCD display under low temperature environment may accelerate lamp exhaustion and reduce luminance dramatically.
- 15) The data on this specification sheet is applicable when LCD module is placed in landscape position.
- 16) Continuous displaying fixed pattern may induce image sticking. It's recommended to use screen saver or shuffle content periodically if fixed pattern is displayed on the screen.

## 2. General Description

This specification applies to the Color Active Matrix Liquid Crystal Display G104VTN01.0 composed of a TFT-LCD display, a driver and power supply circuit, and a LED backlight system.

The screen format is intended to support VGA (640(H) x 480(V)) screen and 262k colors (RGB 6-bits).

LED driving board for backlight unit is included in G104VTN01.0.

G104VTN01.0 is designed with wide viewing angle; wide temperature and long life LED backlight is well suited for industrial applications.

G104VTN01.0 is a RoHS product.

### 2.1 Display Characteristics

The following items are characteristics summary on the table under 25°C condition:

Items	Unit	Specifications
Screen Diagonal	[inch]	10.4
Active Area	[mm]	211.2 (H) x 158.4 (V)
Pixels H x V		640 x 3(RGB) x 480
Pixel Pitch	[mm]	0.33 x 0.33
Pixel Arrangement		R.G.B. Vertical Stripe
Display Mode		TN, Normally White
Nominal Input Voltage VDD	[Volt]	3.3 (Typ.)
Typical Power Consumption	[Watt]	2.42W (LCD: 0.42W, LED BLU Max: 2W) @All black pattern LED=12V
Weight	[Grams]	293g (Typ.)
Physical Size	[mm]	227.3(H) x 177.5(V) x 9.3(D) (Typ.)
Electrical Interface		6bit Parallel RGB
Surface Treatment		Anti-glare, Hardness 3H
Support Color		262K colors
Temperature Range Operating Storage (Non-Operating)	[°C] [°C]	-30 to +80 -30 to +80
RoHS Compliance		RoHS Compliance

## 2.2 Optical Characteristics

The optical characteristics are measured under stable conditions at 25°C (Room Temperature):

Item	Unit	Conditions	Min.	Typ.	Max.	Remark
White Luminance	[cd/m <sup>2</sup> ]	I <sub>F</sub> = 23mA/1 LED Line (center point)	310	370	-	Note 1
Uniformity	%	5 Points	75	-	-	Note 2, 3
Contrast Ratio			500	700	-	Note 4
Response Time	[msec]	Rising	-	20	30	Note 5
	[msec]	Falling	-	10	20	
	[msec]	Raising + Falling	-	30	50	
Viewing Angle	[degree]	Horizontal (Right) (Left) CR = 10	70	80	-	Note 6
	[degree]		70	80	-	
	[degree]	Vertical (Upper) (Lower) CR = 10	50	60	-	
Color / Chromaticity Coordinates (CIE 1931)		Red x	0.540	0.590	0.640	
		Red y	0.292	0.342	0.392	
		Green x	0.291	0.341	0.391	
		Green y	0.523	0.573	0.623	
		Blue x	0.113	0.163	0.213	
		Blue y	0.090	0.140	0.190	
		White x	0.250	0.300	0.350	
		White y	0.270	0.320	0.370	
Color Gamut	%		-	45	-	

Note 1: Measurement method

Equipment Pattern Generator, Power Supply, Digital Voltmeter, Luminance meter (SR\_3 or equivalent)

Aperture 1° with 50cm viewing distance

Test Point Center

Environment < 1 lux

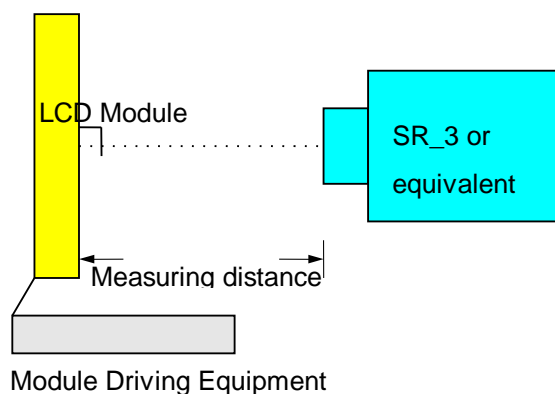

Note 2: Definition of 5 points position (Display active area: 211.2mm (H) x 158.4mm (V))

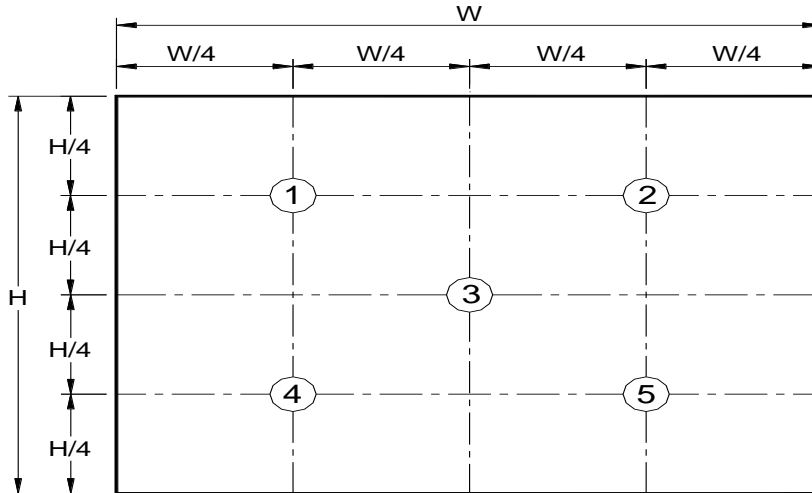

Note 3: The luminance uniformity of 5 points is defined by dividing the minimum luminance values by the maximum test point luminance

$$\delta_{w9} = \frac{\text{Minimum Brightness of five points}}{\text{Maximum Brightness of five points}}$$

Note 4: Definition of contrast ratio (CR):

$$\text{Contrast ratio (CR)} = \frac{\text{Brightness on the "White" state}}{\text{Brightness on the "Black" state}}$$

Note 5: Definition of response time:

The output signals of photo detector are measured when the input signals are changed from "White" to "Black" (falling time) and from "Black" to "White" (rising time), respectively. The response time interval is between 10% and 90% of amplitudes. Please refer to the figure as below.

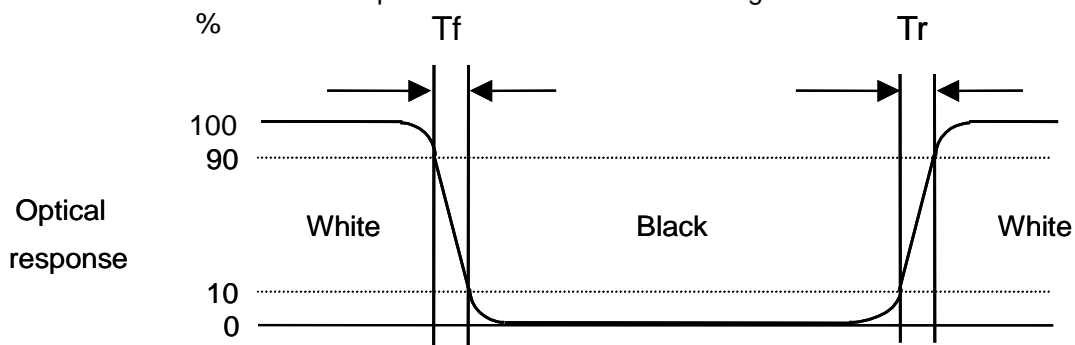

Note 6: Definition of viewing angle

Viewing angle is the measurement of contrast ratio  $\geq 10$ , at the screen center, over a 180° horizontal and 180° vertical range (off-normal viewing angles). The 180° viewing angle range is broken down as below: 90° ( $\theta$ ) horizontal left and right, and 90° ( $\Phi$ ) vertical high (up) and low (down). The measurement direction is typically perpendicular to the display surface with the screen rotated to its center to develop

the desired measurement viewing angle.

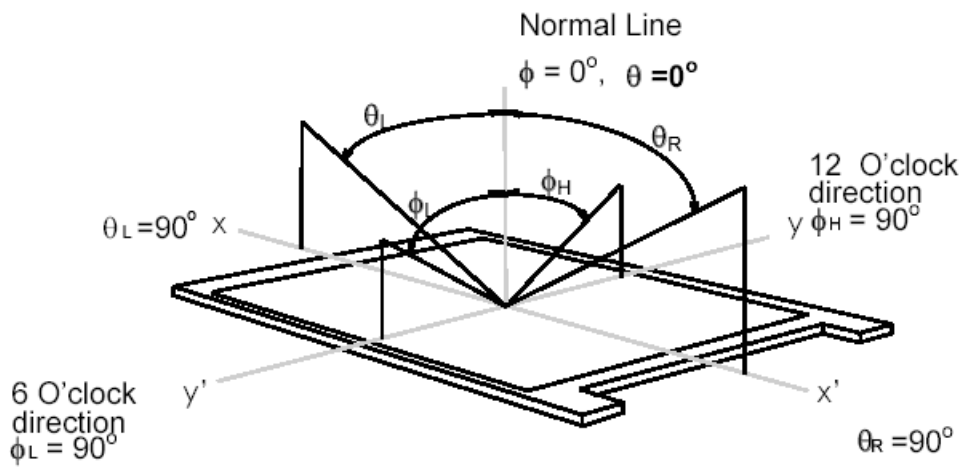

### 3. Functional Block Diagram

The following diagram shows the functional block of the 10.4 inch color TFT/LCD module:

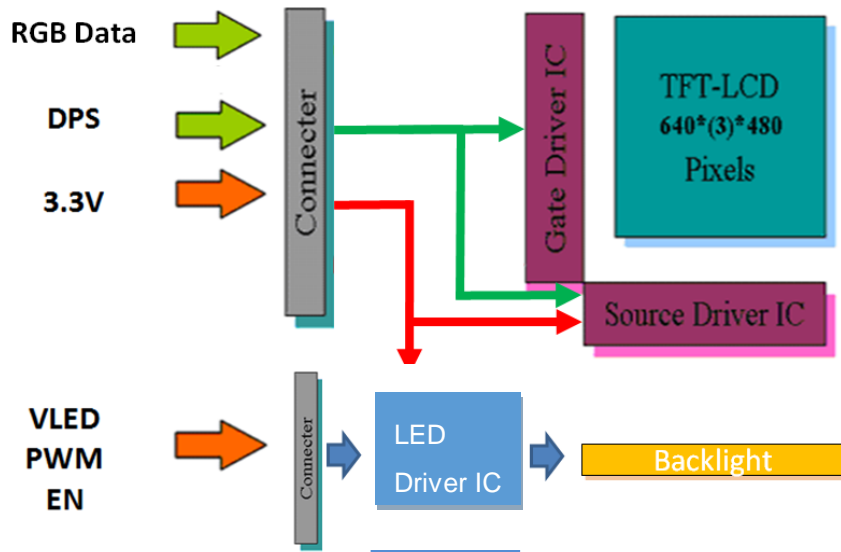

## 4. Absolute Maximum Ratings

### 4.1 Absolute Ratings of TFT LCD Module

Item	Symbol	Min	Max	Unit
Logic/LCD Drive	Vin	-0.3	+3.6	[Volt]

### 4.2 Absolute Ratings of Environment

Item	Symbol	Min	Max	Unit
Operating Temperature	TOP	-30	+80	[°C]
Operation Humidity	HOP	5	95	[%RH]
Storage Temperature	TST	-30	+80	[°C]
Storage Humidity	HST	5	95	[%RH]

Note: Maximum Wet-Bulb should be 39°C and no condensation.

## 5. Electrical Characteristics

### 5.1 TFT LCD Module

#### 5.1.1 Power Specification

Symbol	Parameter	Min	Typ	Max	Units	Remark
VDD	Logic/LCD Input Voltage	3.0	3.3	3.6	[Volt]	
I <sub>VDD</sub>	LCD Input Current	-	115	127	[mA]	VDD=3.3V at 60 HZ, all Black Pattern
P <sub>VDD</sub>	LCD Power consumption	-	0.38	0.42	[Watt]	VDD=3.3V at 60 HZ, all Black Pattern
I <sub>rush LCD</sub>	LCD Inrush Current	-	-	1.5	[A]	Note 1; VDD=3.3V Black Pattern, Rising time=470us
VDD <sub>rp</sub>	Allowable Logic/LCD Drive Ripple Voltage	-	-	100	[mV] p-p	VDD=3.3V at 60 HZ, all Black Pattern

Note 1: Measurement condition:

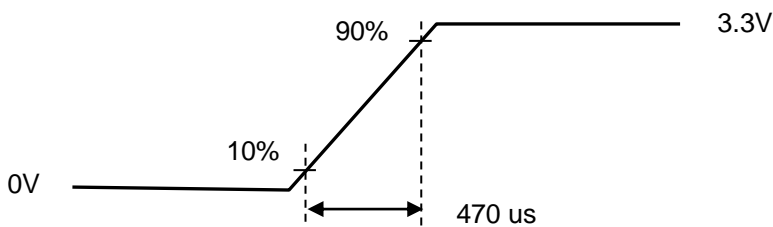
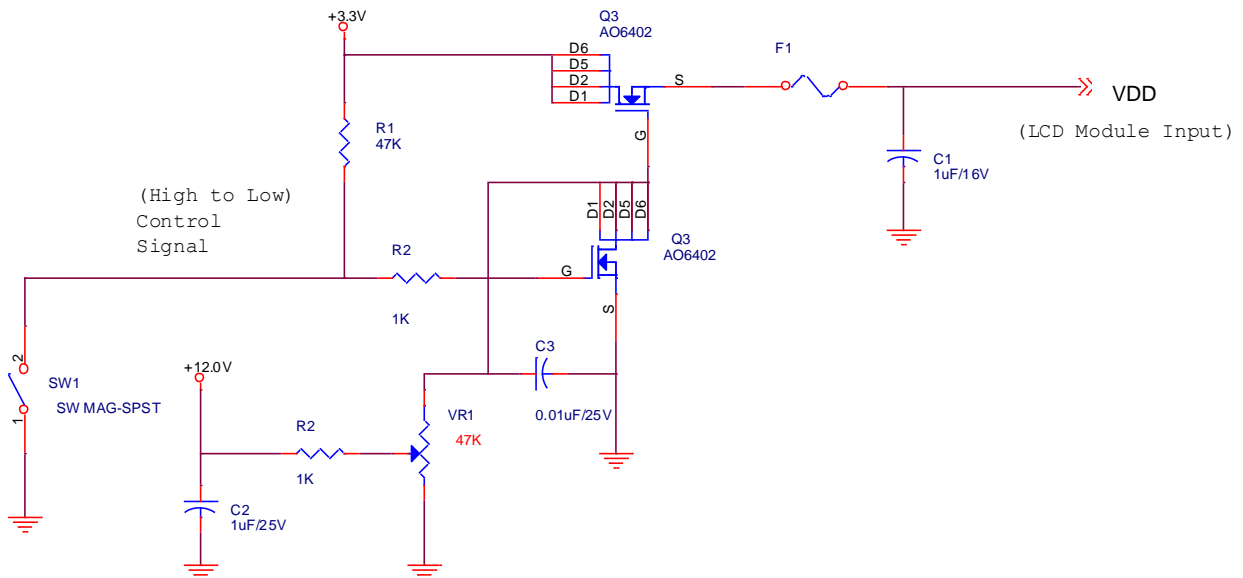

VDD rising time

### 5.1.2 Signal Electrical Characteristics

Input signals shall be low or Hi-Z state when VDD is off.

Parameter		Symbol	Min.	Typ.	Max.	Unit	Remarks
Logic Input Voltage for Display Signals	High	VIH	0.7VDD	-	VDD	Volt	
	Low	VIL	0	-	0.3VDD	Volt	
Input Voltage for RL/UD	High	VIH	0.7VDD	-	VDD	Volt	
	Low	VIL	0	-	0.3VDD	Volt	

## 5.2 Backlight Unit

### 5.2.1 Parameter guideline for LCD

Following characteristics are measured under a stable condition using an inverter at 25°C. (Room Temperature):

Symbol	Parameter		Min.	Typ.	Max.	Unit	Remark
<b>VLED</b>	Input Voltage		10.8	12	13.2	[Volt]	
<b>I<sub>LED</sub></b>	Input Current		-	-	167	[mA]	VLED=12V & 100% PWM Duty
<b>P<sub>LED</sub></b>	Power Consumption		-	-	2000	[mW]	VLED=12V & 100% PWM Duty
<b>V<sub>EN</sub></b>	EN Control Level	BL On	2.5	-	5.5	[Volt]	
		BL Off	0	-	0.5	[Volt]	
<b>F<sub>PWM</sub></b>	Dimming Frequency		500	-	1K	[Hz]	
<b>D<sub>PWM</sub></b>	Dimming Duty Cycle		5	-	100	%	
<b>V<sub>PWM</sub></b>	Dimming Control Level	High Level	2.5	-	5.5	[Volt]	
		Low Level	0	-	0.5	[Volt]	
<b>LED life time</b>			70,000	100,000	-	Hrs	I <sub>F</sub> = 23mA, Ta = 25°C

Note 1: Ta means ambient temperature of TFT-LCD module.

Note 2: VLED, ILED, PLED are defined for LED backlight. (100% duty of PWM dimming)

Note 3: IF, VF are defined for one channel LED. There are two LED channel in back light unit.

Note 4: If G104VTN01.0 module is driven by high current or at high ambient temperature & humidity condition. The operating life will be reduced.

Note 5: Operating life means brightness goes down to 50% initial brightness. Minimum operating life time is estimated data.

## 6. Signal Characteristics

### 6.1 Pixel Format Image

Following figure shows the relationship between input signal and LCD pixel format.

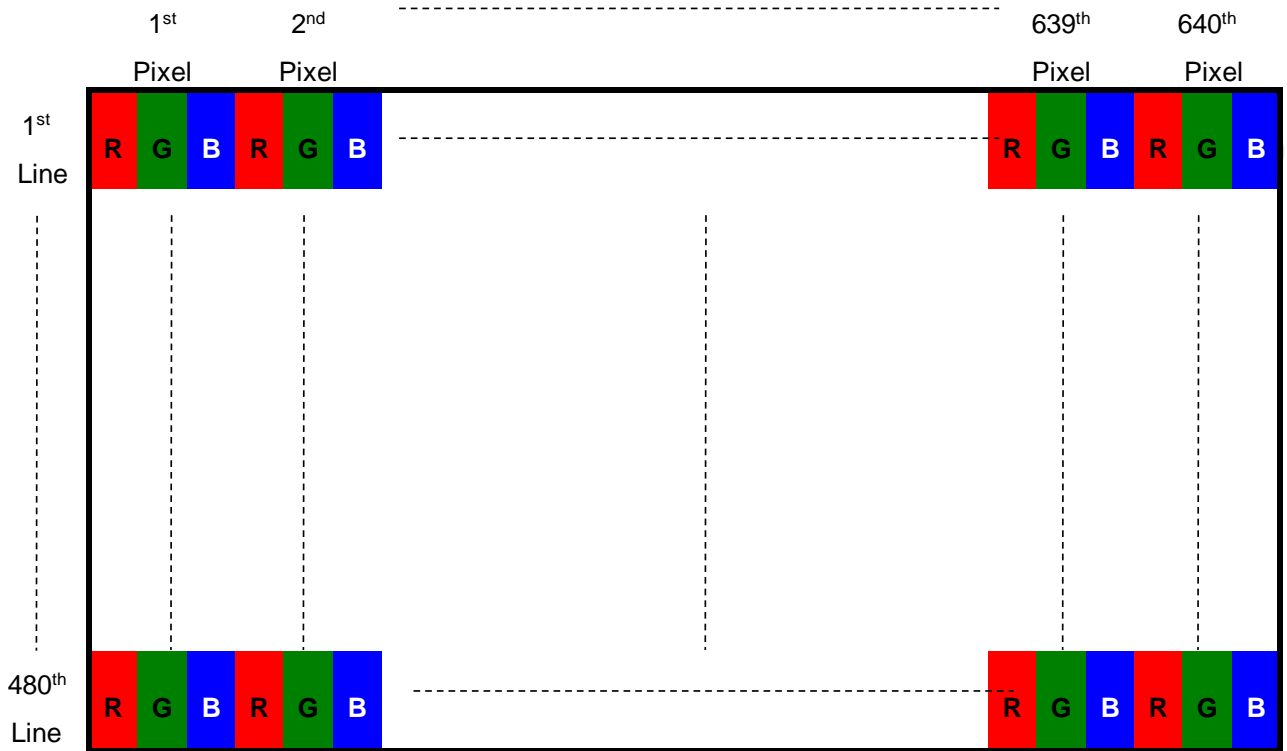

## 6.2 TFT-LCD Interface Signal Description

Input Signal Interface		
Pin No.	Symbol	Description
1	GND	Ground
2	CLK	Dot clock
3	HSYNC	Horizontal sync (do not need)
4	VSYNC	Vertical sync (do not need)
5	GND	Ground
6	R0	Red data Signal
7	R1	Red data Signal
8	R2	Red data Signal
9	R3	Red data Signal
10	R4	Red data Signal
11	R5	Red data Signal
12	GND	Ground
13	G0	Green data Signal
14	G1	Green data Signal
15	G2	Green data Signal
16	G3	Green data Signal
17	G4	Green data Signal
18	G5	Green data Signal
19	GND	Ground
20	B0	Blue data Signal
21	B1	Blue data Signal
22	B2	Blue data Signal
23	B3	Blue data Signal
24	B4	Blue data Signal
25	B5	Blue data Signal
26	GND	Ground
27	DE	Data Enable Signal
28	VDD	Power Supply, 3.3V (typical)
29	VDD	Power Supply, 3.3V (typical)
30	NC	NC
31	DPS	Reverse Scan Function [Note 4]
32	NC	Reserved for AUO internal test. Please treat it as NC.
33	NC	Reserved for AUO internal test. Please treat it as NC.
34	NC	Reserved for AUO internal test. Please treat it as NC.
35	NC	NC
36	NC	Reserved for AUO internal test. Please treat it as NC.
37	NC	Reserved for AUO internal test. Please treat it as NC.
38	NC	NC
39	NC	Reserved for AUO internal test. Please treat it as NC.
40	NC	Reserved for AUO internal test. Please treat it as NC.

Note 1: Input Signals shall be in low status when VDD is off.

Note 2: High stands for "3.3V", Low stands for "0V", NC stands for "No Connection".

Note 3: R/G/B data 5: MSB, R/G/B data 0: LSB

Note 4:

The following figures show the image seen from the front view. The arrow indicates the direction of scan.

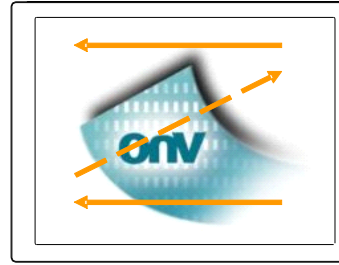
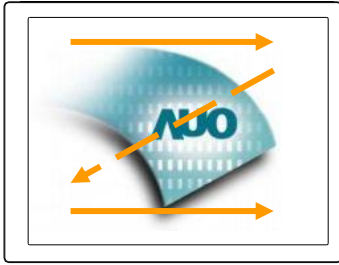

### 6.3 The Input Data Format

This product displays 262,144 colors in terms of the 64 grey levels on RGB respectively. The following table demonstrates the display of input data.

Signal Name	Description	Remark
R7	Red Data 7	Red-pixel Data  For 8Bits input MSB: R7 ; LSB: R0  For 6Bits input MSB: R5 ; LSB: R0
R6	Red Data 6	
R5	Red Data 5	
R4	Red Data 4	
R3	Red Data 3	
R2	Red Data 2	
R1	Red Data 1	
R0	Red Data 0	
G7	Green Data 7	Green-pixel Data  For 8Bits input MSB: G7 ; LSB: G0  For 6Bits input MSB: G5 ; LSB: G0
G6	Green Data 6	
G5	Green Data 5	
G4	Green Data 4	
G3	Green Data 3	
G2	Green Data 2	
G1	Green Data 1	
G0	Green Data 0	
B7	Blue Data 7	Blue-pixel Data  For 8Bits input MSB: B7 ; LSB: B0  For 6Bits input MSB: B5 ; LSB: B0
B6	Blue Data 6	
B5	Blue Data 5	
B4	Blue Data 4	
B3	Blue Data 3	
B2	Blue Data 2	
B1	Blue Data 1	
B0	Blue Data 0	
CLK	Data Clock	Falling Latch
DE	Data Enable Signal	When the signal is high, the pixel data shall be valid to be displayed.

Note: Output signals from any system shall be low or Hi-Z state when VDD is off.

## 6.4 TFT-LCD Interface Timing

### 6.4.1 Timing Characteristics

Signal	Symbol	Min.	Typ.	Max.	Unit	
Clock Frequency	$1/T_{\text{Clock}}$	23.23	24.19	28.5	MHz	
Vertical Section	Period	$T_V$	517	525	580	Vertical Section
	Active	$T_{VD}$	--	480	--	
	Blanking	$T_{VB}$	37	45	100	
Horizontal Section	Period	$T_H$	750	800	900	Horizontal Section
	Active	$T_{HD}$	--	640	--	
	Blanking	$T_{HB}$	110	160	260	
Frame Rate	F	60	Hz			

Note: DE mode.

### 6.5.2 Input Timing Diagram

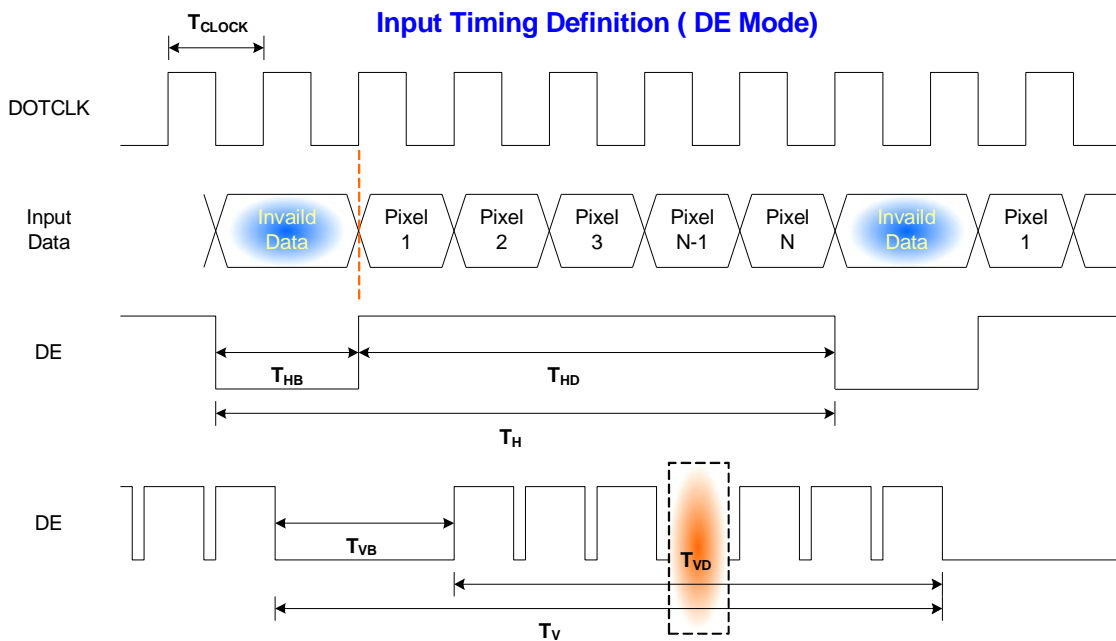

### 6.5 Power ON/OFF Sequence

VDD power and lamp on/off sequence is as below. Interface signals are also shown in the chart. Signals from any system shall be Hi-Z state or low level when VDD is off.

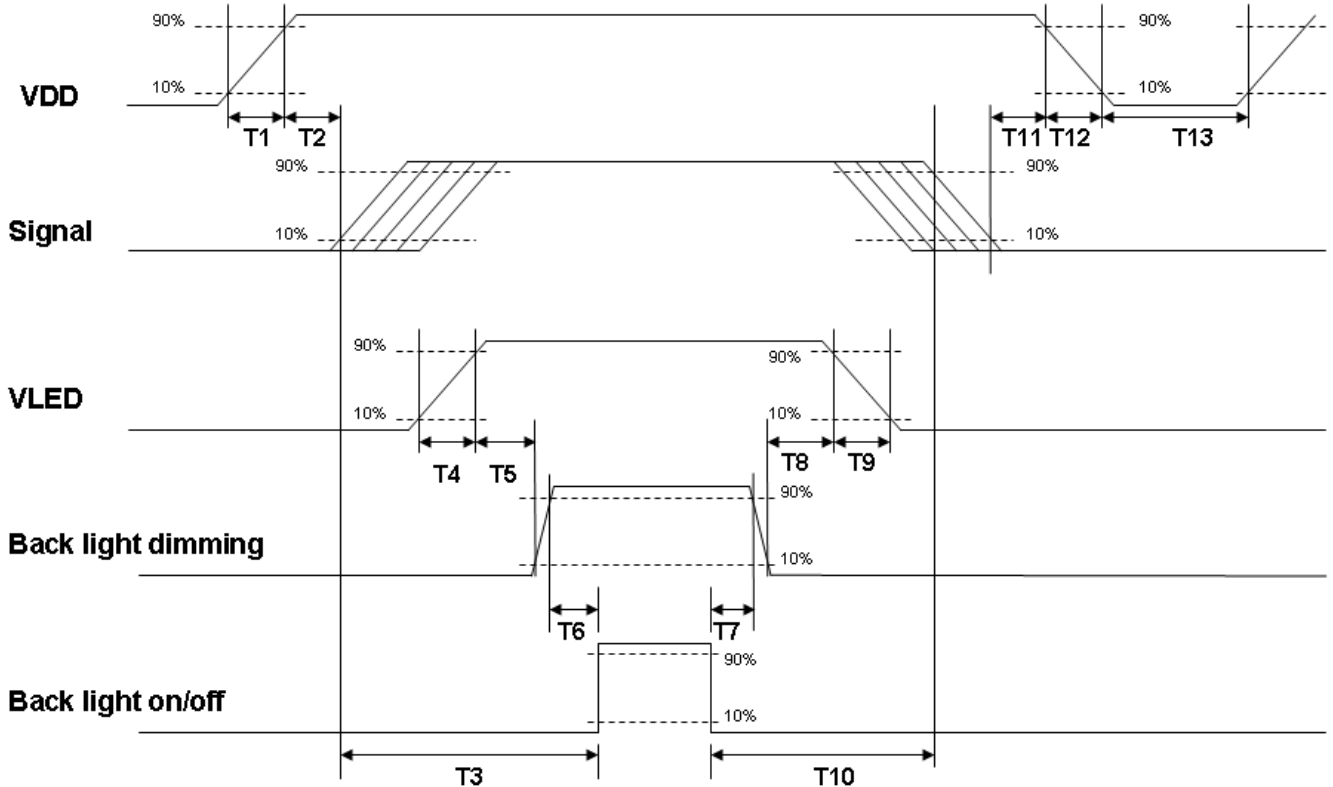

**Power ON/OFF sequence timing**

Parameter	Value			Units
	Min.	Typ.	Max.	
T1	0.5	-	10	[ms]
T2	30	40	50	[ms]
T3	200	--	--	[ms]
T4	0.5	--	10	[ms]
T5	10	-	-	[ms]
T6	10	-	-	[ms]
T7	0	-	-	[ms]
T8	10	-	-	[ms]
T9	--	--	10	[ms]
T10	110	--	--	[ms]
T11	0	16	50	[ms]
T12	-	-	10	[ms]
T13	1000	-	-	[ms]

The above on/off sequence should be applied to avoid abnormal function in the display. Please make sure to turn off the power when you plug the cable into the input connector or pull the cable out of the connector.

## 7. Connector & Pin Assignment

Physical interface is described as for the connector on module. These connectors are capable of accommodating the following signals and will be following components.

### 7.1 TFT-LCD Signal (CN1): LCD Connector

<b>Connector Name / Designation</b>	<b>Signal Connector</b>
Manufacturer	HRS
Connector Model Number	FH63F-40S-0.5SH

Pin No.	Symbol	Pin No.	Symbol	Pin No.	Symbol	Pin No.	Symbol
1	GND	11	R5	21	B1	31	DPS
2	CLK	12	GND	22	B2	32	NC
3	HSYNC	13	G0	23	B3	33	NC
4	VSYNC	14	G1	24	B4	34	NC
5	GND	15	G2	25	B5	35	NC
6	R0	16	G3	26	GND	36	NC
7	R1	17	G4	27	DE	37	NC
8	R2	18	G5	28	VDD	38	NC
9	R3	19	GND	29	VDD	39	NC
10	R4	20	B0	30	NC	40	NC

### 7.2 LED Backlight Unit (CN2): Backlight Connector

<b>Connector Name / Designation</b>	<b>Lamp Connector</b>
Manufacturer	JAE
Connector Model Number	FI-S6P-HFE
Mating Model Number	FI-S6S or compatible

Pin No.	symbol	description
Pin1	VLED	12V input
Pin2	VLED	12V input
Pin3	GND	GND
Pin4	GND	GND
Pin5	VLEN	3.3~5V-ON,0V-OFF
Pin6	VPWM	5V ON, 0V-OFF

## 8. Reliability Test Criteria

Items	Required Condition	Note
Temperature Humidity Bias	40°C, 90%RH, 300 hours	
High Temperature Operation	80°C, 300 hours	
Low Temperature Operation	-30°C, 300 hours	
Hot Storage	80°C, 300 hours	
Cold Storage	-30°C, 300 hours	
Thermal Shock Test	-20°C / 30 mins, 60°C / 30 mins, 100cycles, 40°C minimum ramp rate	
Hot Start Test	80°C / 1Hr mins, power on/off per 5 minutes, 5 times	
Cold Start Test	-30°C / 1Hr mins, power on/off per 5 minutes, 5 times	
Shock Test (Non-Operating)	50G, 20ms, Half-sine wave, ( $\pm X$ , $\pm Y$ , $\pm Z$ )	
Vibration Test (Non-Operating)	1.5G, (10~200Hz, Sine wave) 30 mins/axis, 3 direction (X, Y, Z)	
On/off test	On/10 sec, Off/10 sec, 30,000 cycles	
ESD	Contact Discharge: $\pm 8KV$ , 150pF (330 $\Omega$ ) 1sec, 8 points, 25 times/ point Air Discharge: $\pm 15KV$ , 150pF (330 $\Omega$ ) 1sec, 8 points, 25 times/ point	Note 1
EMI	30-230 MHz, limit 40 dBu V/m, 230-1000 MHz, limit 47 dBu V/m	

Note1: According to EN61000-4-2, ESD class B: Some performance degradation allowed. No data lost  
Self-recoverable. No hardware failures.

Note2:

- Water condensation is not allowed for each test items.
- Each test is done by new TFT-LCD module. Don't use the same TFT-LCD module repeatedly for reliability test.
- The reliability test is performed only to examine the TFT-LCD module capability.
- To inspect TFT-LCD module after reliability test, please store it at room temperature and room humidity for 24 hours at least in advance.

## 9. Mechanical Characteristics

### 9.1 LCM Outline Dimension (Front View)

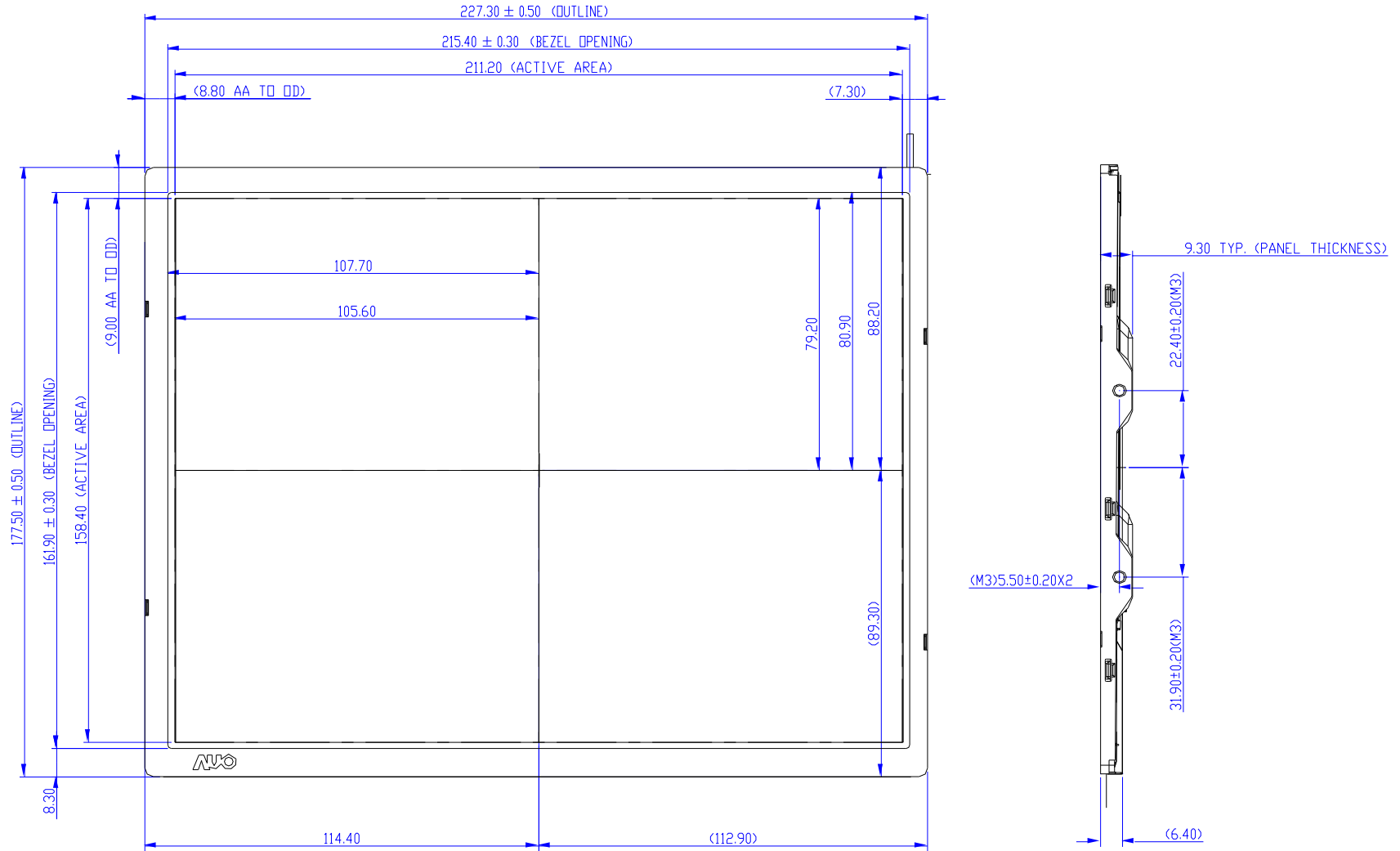

## 9.2 LCM Outline Dimension (Rear View)

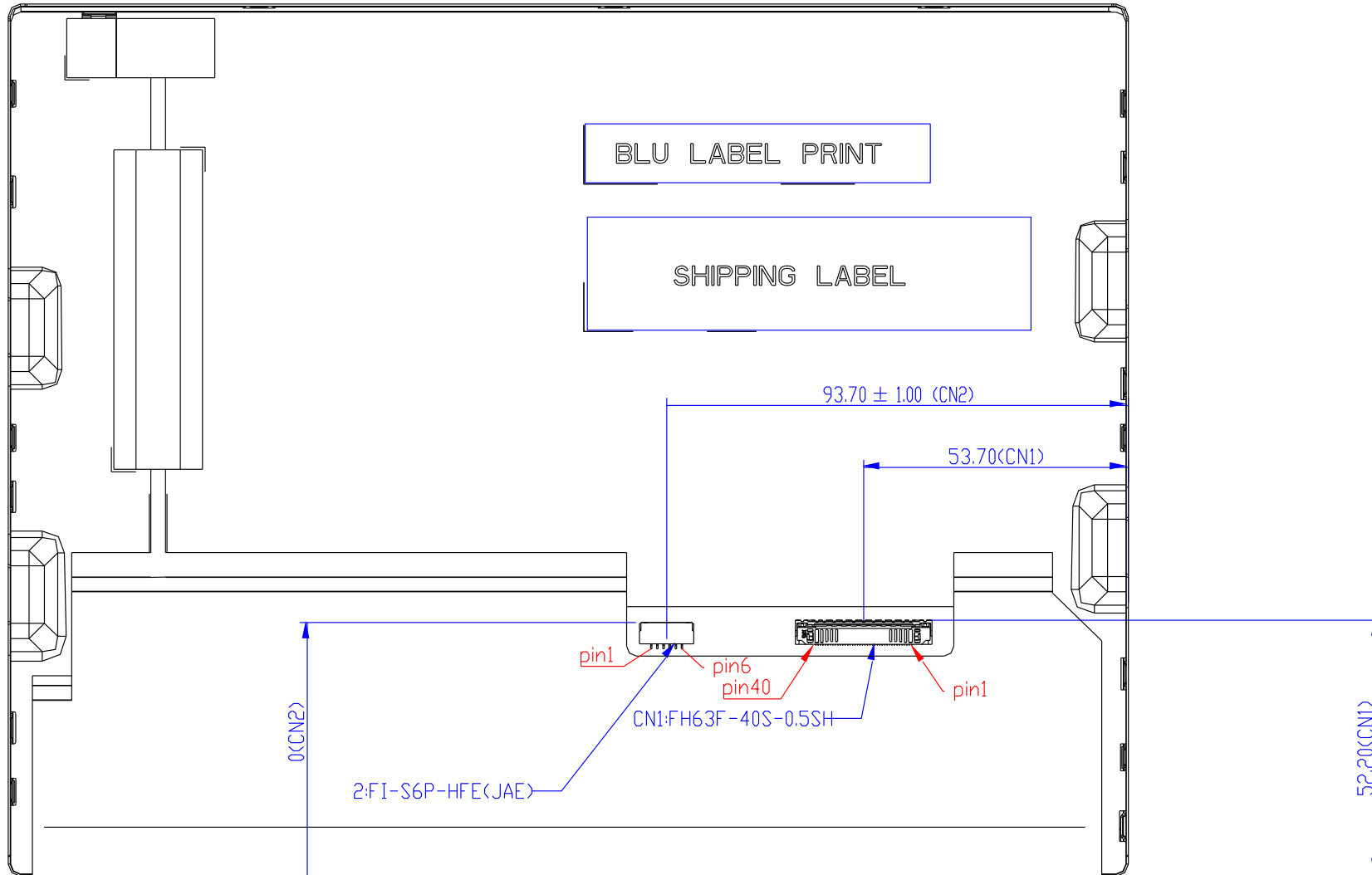

## 10. Label and Packaging

### 10.1 Shipping Label (on the rear side of TFT-LCD display)

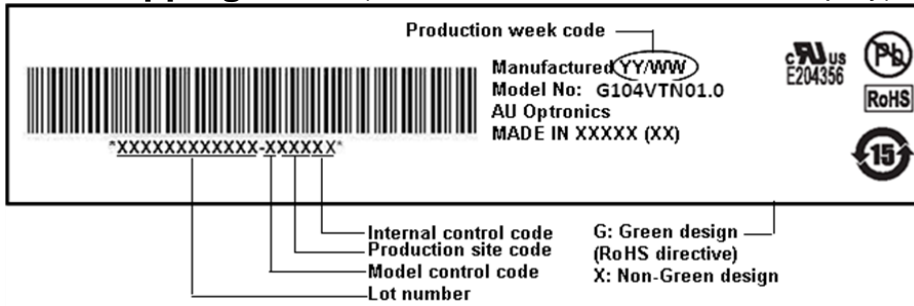

### 10.2 Carton Package

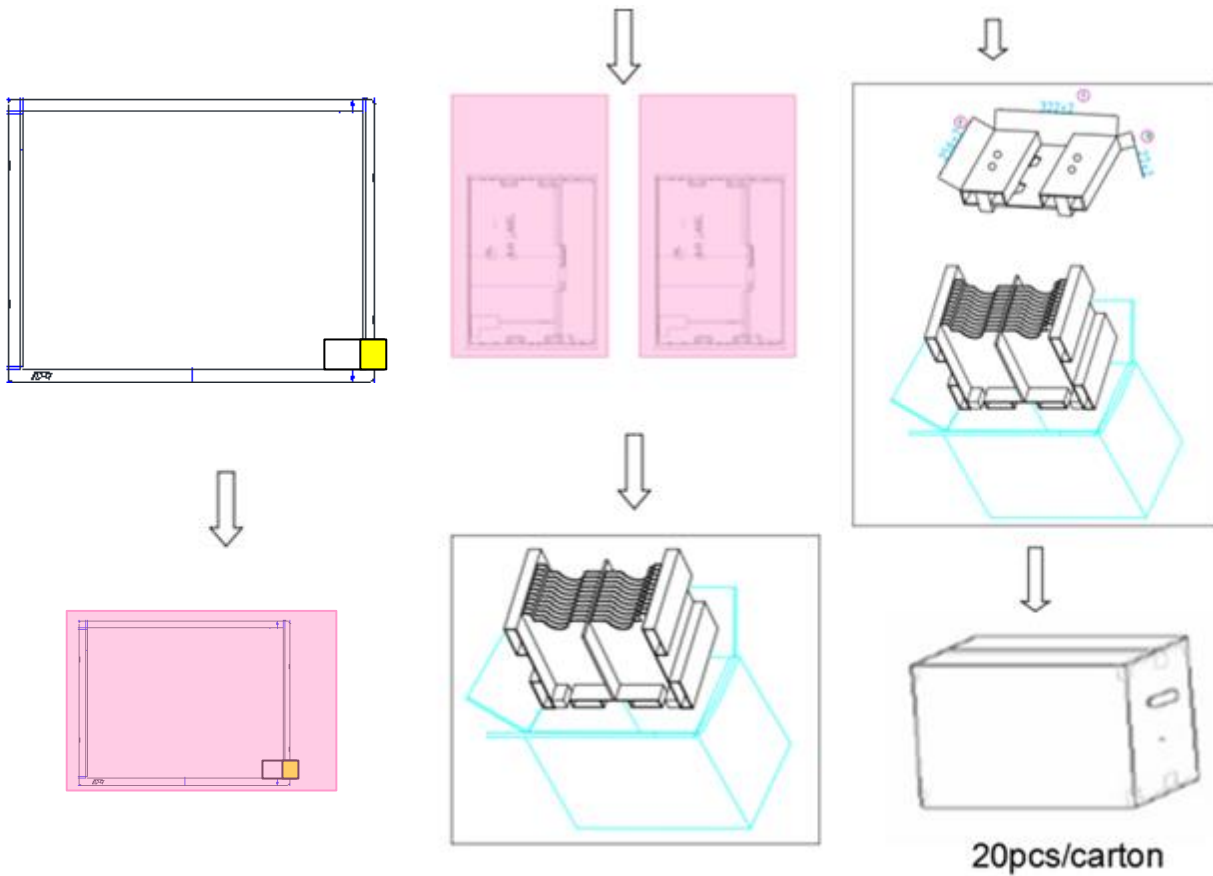

## **11 Safety**

### **11.1 Sharp Edge Requirements**

There will be no sharp edges or comers on the display assembly that could cause injury.

### **11.2 Materials**

#### **11.2.1 Toxicity**

There will be no carcinogenic materials used anywhere in the display module. If toxic materials are used, they will be reviewed and approved by the responsible AUO toxicologist.

#### **11.2.2 Flammability**

All components including electrical components that do not meet the flammability grade UL94-V1 in the module will complete the flammability rating exception approval process.

The printed circuit board will be made from material rated 94-V1 or better. The actual UL flammability rating will be printed on the printed circuit board.

### **11.3 Capacitors**

If any polarized capacitors are used in the display assembly, provisions will be made to keep them from being inserted backwards.

### **11.4 National Test Lab Requirement**

The display module will satisfy all requirements for compliance to:

**UL 1950, First Edition**

U.S.A. Information Technology Equipment