

**TITLE :DV750QUB-R01****Product Specification****REV. P0****HEFEI BOE DISPLAY TECHNOLOGY Co.,LTD.**SPEC. NUMBER  
S8-65-AA-064PRODUCT GROUP  
TFT-LCD

REV.E

ISSUE DATE  
2019.12.20PAGE  
1 OF 43

**REVISION HISTORY**

(  ) preliminary specification

(  ) Final specification

Revision No.	Page	Description of changes	Date	Prepared
P0	Total Page	Initial Release	2019.12.20	Yi Hong Liang

## Contents

No.	Item	Page
1.0	GENERAL DESCRIPTION	4
2.0	ABSOLUTE MAXIMUM RATINGS	6
3.0	ELECTRICAL SPECIFICATIONS	7
4.0	INTERFACE CONNECTION	13
5.0	SIGNAL TIMING WAVEFORMS OF INTERFACE SIGNAL	19
6.0	SIGNAL TIMING SPECIFICATION	20
7.0	OPTICAL SPECIFICATION	24
8.0	MECHANICAL CHARACTERISTICS	27
9.0	RELIABILITY TEST	28
10.0	PRECAUTIONS	29
11.0	PRODUCT SERIAL NUMBER	34
12.0	PACKING	35
13.0	APPENDIX	38

## 1.0 GENERAL DESCRIPTION

### 1.1 Introduction

DV750QUB-R01 is a color active matrix TFT LCD open cell using amorphous silicon TFT's (Thin Film Transistors) as an active switching devices. This module has a 75 inch diagonally measured active area with UHD resolutions (3840 horizontal by 2160 vertical pixel array). Each pixel is divided into RED, GREEN, BLUE dots which are arranged in vertical stripe and this module can display 1.07G colors. The TFT-LCD panel used for this module is adapted for a low reflection and higher color type.

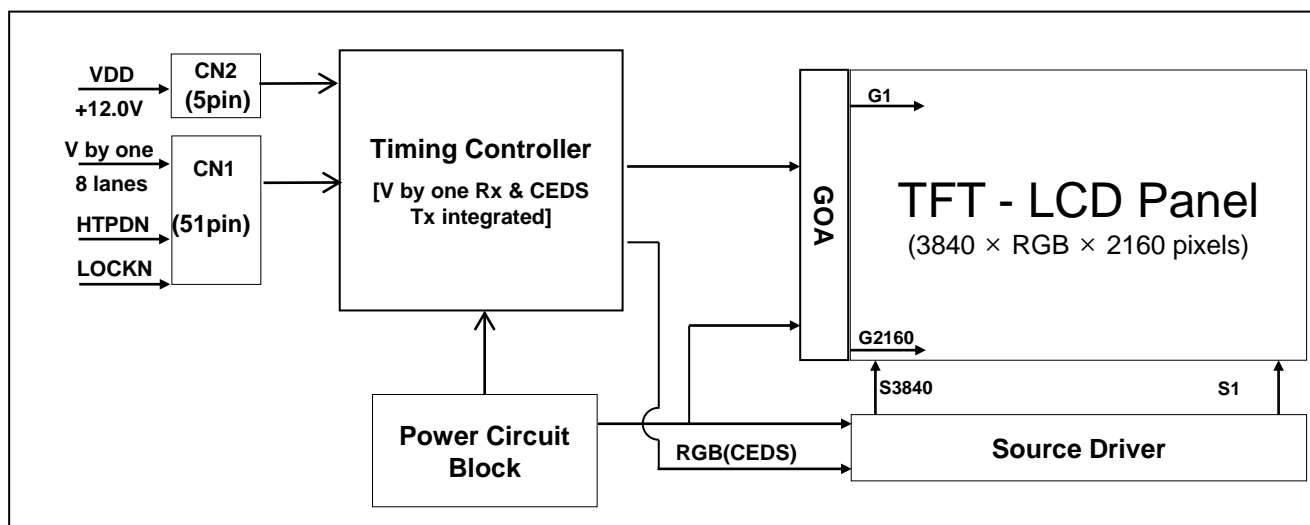

### 1.2 Features

- V by one interface with 8 lanes
- High-speed response
- Low color shift image quality
- 8-bit + FRC color depth, display 1.07G colors
- High luminance and contrast ratio, low reflection and wide viewing angle
- Gate driver use GOA mode
- ADS technology is applied for high display quality
- RoHS compliant
- High TNI 105°C
- Compatibility of direction H/V

## 1.3 Application

- Commercial Digital Display
- Display Terminals for Control System
- Landscape and Portrait Display
- Electronic Signage(Outdoor , Compatibility of direction H/V)

## 1.4 General Specification

&lt; Table 1. General Specifications &gt;

Parameter	Specification	Unit	Remark
Active area	1649.664(H) × 927.936(V)	mm	
Number of pixels	3840*(RGB)*2160	pixels	
Pixel pitch	429.6(H) × 429.6(V)	μm	
Pixel arrangement	Pixels RGB Vertical stripe		
Display colors	1.07G (8bits + FRC )	colors	8bit driver IC
Display mode	ADS		
Open Cell Transmittance	5.5%(Typ.)	%	At center point with BOE BLU
Weight	4850(Typ.)	gram	
Power Consumption	12(TYP.)	Watt	Mosaic 8*6
Surface Treatment	Haze 1%, 3H, Anti-glare treatment (Front Polarizer) Clear (Bottom Polarizer)		
Temperature	Operating	-30~80	°C High TNI 105°C
	Storage	-30~80	

### 2.0 ABSOLUTE MAXIMUM RATINGS

The followings are maximum values which, if exceed, may cause faulty operation or damage to the unit. The operational and non-operational maximum voltage and current values are listed in Table 2.

< Table 2. Open Cell Absolute Maximum Ratings > [VSS=GND=0V]

Parameter	Symbol	Min.	Max.	Unit	Remark
Operating Temperature	T <sub>OP</sub>	-30	+80	°C	Note
	T <sub>Sur</sub>	-30	+82	°C	
Storage Temperature	T <sub>ST</sub>	-30	+80	°C	
Operating Ambient Humidity	Hop	10	80	%RH	
Storage Humidity	Hst	10	80	%RH	

Note 1 : The operating test condition is based on BOE backlight.

Note 2 : Temperature and relative humidity range are shown in the figure below.

Note 3 : Wet bulb temperature should be 39 °C max. and no condensation of water.

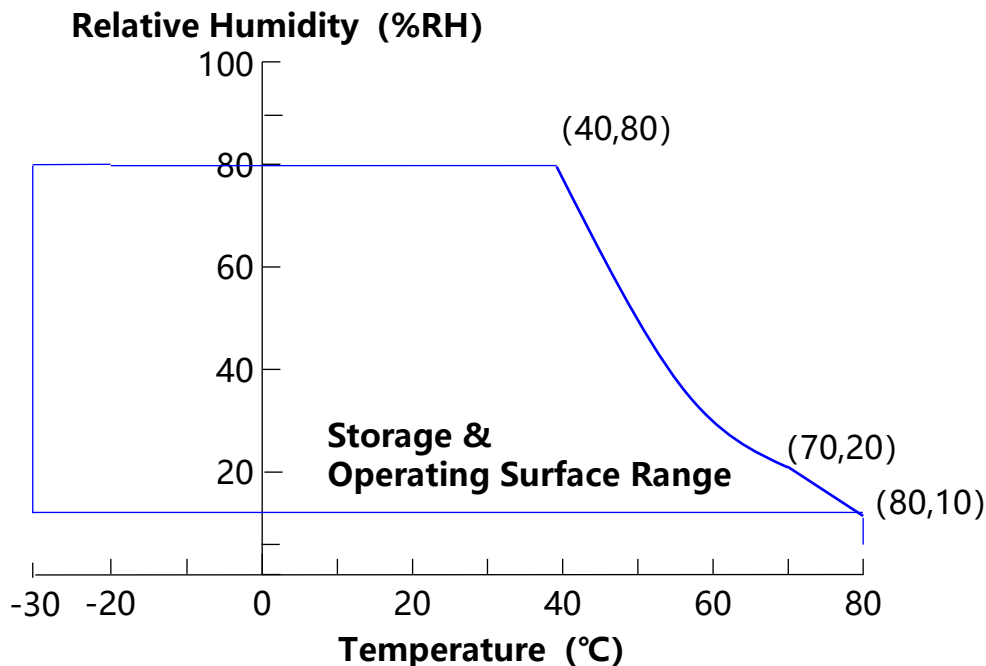

### 3.0 ELECTRICAL SPECIFICATIONS

#### 3.1 TFT LCD Open Cell

< Table 3. Open Cell Electrical Specifications >

[Ta =25 ± 2 °C]

Parameter		Symbol	Values			Unit	Remark
			Min	Typ	Max		
Power Supply Input Voltage		VDD	10.8	12	14	Vdc	
Power Supply Ripple Voltage		VRP	-	-	600	mV	
Power Supply Current		IDD	-	700	2000	mA	Note 1
Power Consumption		PDD	-	8.4	24	Watt	
Rush current		IRUSH	-	-	10	A	Note 2
V by One Interface	Differential Input High Threshold Voltage	VLVTH	-	-	+50	mV	-
	Differential Input Low Threshold Voltage	VLVTL	-50	-	-	mV	-
	Common Input Voltage	VLVC	-	-	-	V	-
	Terminating Resistor	Rt	90	100	110	ohm	-
	EQ Value	dB		Auto EQ			Appendix 5
CMOS Interface	Input High Threshold Voltage	VIH	2.7	-	3.3	V	
	Input Low Threshold Voltage	VIL	0	-	0.6	V	

Note 1 : The supply voltage is measured and specified at the interface connector of LCM.

The current draw and power consumption specified is for VDD=12.0V,

Frame rate  $f_v=60\text{Hz}$  and Clock frequency = 74.25MHz.

Test Pattern of power supply current

Note 2 : The duration of rush current is about 2ms and rising time of Power Input is 0.5ms(min)

### 3.2 FLICKER PATTERN

	Pixel1			Pixel2			Pixel3			Pixel4		
Display	R	G	B	R	G	B	R	G	B	R	G	B
	+	-	+	-	+	-	+	-	+	-	+	-
	R	G	B	R	G	B	R	G	B	R	G	B
	-	+	-	+	-	+	-	+	-	+	-	+
	R	G	B	R	G	B	R	G	B	R	G	B
	+	-	+	-	+	-	+	-	+	-	+	-
	R	G	B	R	G	B	R	G	B	R	G	B
	-	+	-	+	-	+	-	+	-	+	-	+
	R	G	B	R	G	B	R	G	B	R	G	B
	+	-	+	-	+	-	+	-	+	-	+	-

### 3.3 POWER CONSUMPTION PATTERN

a) Typ : Mosaic 8 x 6 Pattern(L0/L255 )

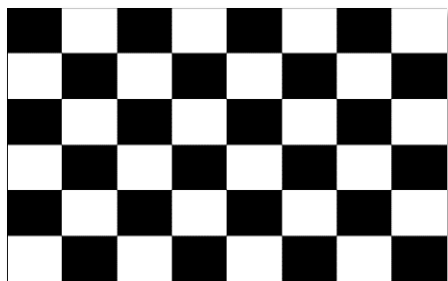

b) Max : Horizontal 1 Line (L0/L255 )



< Table 4. Power consumption >

Parameter	Symbol	Min	Typ	Max	Unit
Power Consumption	PDD	-	8.4	24	W
Power Supply Current	IDD	-	700	2000	mA

Notes : Power consumption & current were measured by BOE T/con board.  
Input Voltage was 12.0V

### 3.4 TCON Characteristics

< Table 5. TCON Characteristics >

Parameter	Symbol	Values			Unit	Remark
		Min	Typ	Max		
TCON Surface Temperature	$T_{TS}$	-	-	125	°C	Note

Note 1 : Any point on the TCON surface must be less than 125 °C under any conditions.

Note 2 : This test condition is based on BOE module.

### 3.5 Driver Characteristics

< Table 6. Driver Characteristics >

Parameter	Symbol	Values			Unit	Remark
		Min	Typ	Max		
Driver Surface Temperature	$T_{DS}$	-	-	125	°C	Note

Note 3 : Any point on the driver surface must be less than 125 °C under any conditions.

Note 4: This test condition is based on BOE module.

### 3.6 PMIC Characteristics

< Table 7. PMIC Characteristics >

Parameter	Symbol	Values			Unit	Remark
		Min	Typ	Max		
PMIC Surface Temperature	$T_{PS}$	-	-	100	°C	Note

Note 5 : Any point on the PMIC surface must be less than 100 °C under any conditions.

Note 6: This test condition is based on BOE module.

### 3.7 VCOM I2C Bus Format

Step1. Write data to VCOM Register  
(DVCOM Register Adjustment)

START	Slave Address	WR	ACK	DVR Register	ACK	DATA	ACK	STOP
	1 1 1 0 1 0 0			0 0 0 0 0 0 0 0 1		D7 D6 D5 D4 D3 D2 D1 D0		



Step2. Write DVCOM Register data to EEPROM  
(After the VCOM adjustment, write the DVCOM data of register to EEPROM)

START	Slave Address	WR	ACK	DVR Register	ACK	DATA	ACK	STOP
	1 1 1 0 1 0 0			0 0 0 0 0 0 0 0 0		0 0 0 0 1 0 0 0		



Register Table:

Register	Bit7	Bit6	Bit5	Bit4	Bit3	Bit2	Bit1	Bit0	Bank	Note
0x00	CTRL BYTE[7:0]								-	Control byte
0x01	DVR[6:0]								-	Digital VCOM

### 3.8 Tw(Write cycle)

Parameter	Symbol	I2C Command	Min.	Typ.	Max	Unit
Write Cycle Time	TW1	Write Register	10	-	-	ms
	TW2	Write EEPROM	-	32	640	ms

Case1.

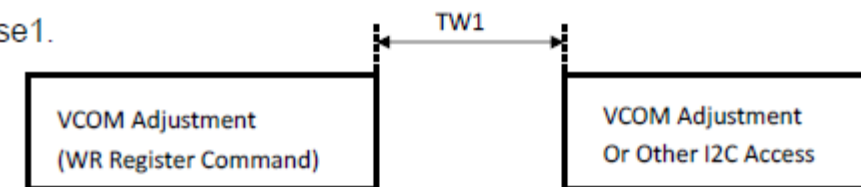

Case2.

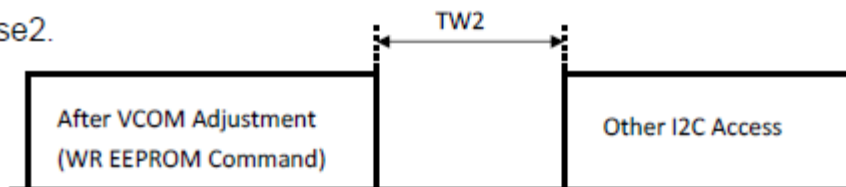

### 3.9 CEDS Eye Diagram Measurement Settings

< CEDS Eye Diagram Measurement Settings >

Oscilloscope PLL setting	
PLL type	2 <sup>nd</sup> order PLL (=Type II PLL)
Damping Factor	Default (0.7)
Bandwidth	3MHz

Remark :

- Please use the measurement results just for your reference.

### 3.10 VBO Eye Diagram Measurement Settings

#### < VBO Eye Diagram Measurement Settings >

Oscilloscope PLL setting	
PLL type	2 <sup>nd</sup> order PLL (=Type II PLL)
Damping Factor	1.0
Bandwidth	10MHz

Remark :

- Please use the measurement results just for your reference.

#### < EQ Profile Settings >

Parameter	HBR
ADC	1.0
Fz(Ghz)	0.725
fp1(Ghz)	1.35
fp2(Ghz)	2.5

## 4.0 INTERFACE CONNECTION

### 4.1 Open Cell Input Signal & Power

- V by one Connector : GT05S-51S-H38-E1500 (LS) or PM.LVS.S040505103(UJC) or BOE -120514-02 (Deren).

< Table 8. Open Cell Input Connector Pin Configuration >

Pin No	Symbol	Description	Pin No	Symbol	Description
1	VDD	Power Supply +12.0V	27	GND	Ground
2	VDD	Power Supply +12.0V	28	Rx0n	V-by-One HS Data Lane 0
3	VDD	Power Supply +12.0V	29	Rx0p	V-by-One HS Data Lane 0
4	VDD	Power Supply +12.0V	30	GND	Ground
5	VDD	Power Supply +12.0V	31	Rx1n	V-by-One HS Data Lane 1
6	VDD	Power Supply +12.0V	32	Rx1p	V-by-One HS Data Lane 1
7	VDD	Power Supply +12.0V	33	GND	Ground
8	VDD	Power Supply +12.0V	34	Rx2n	V-by-One HS Data Lane 2
9	NC	No Connection	35	Rx2p	V-by-One HS Data Lane 2
10	GND	Ground	36	GND	Ground
11	GND	Ground	37	Rx3n	V-by-One HS Data Lane 3
12	GND	Ground	38	Rx3p	V-by-One HS Data Lane 3
13	GND	Ground	39	GND	Ground
14	GND	Ground	40	Rx4n	V-by-One HS Data Lane 4
15	NC	No Connection	41	Rx4p	V-by-One HS Data Lane 4
16	NC	No Connection	42	GND	Ground
17	NC	No Connection	43	Rx5n	V-by-One HS Data Lane 5
18	SDA	Tcon_SDA_IN	44	Rx5p	V-by-One HS Data Lane 5
19	SCL	Tcon_SCL_IN	45	GND	Ground
20	NC	No Connection	46	Rx6n	V-by-One HS Data Lane 6
21	NC	No Connection	47	Rx6p	V-by-One HS Data Lane 6
22	Section	L : 1 division, H : 2 division, Default: L	48	GND	Ground
23	NC	No Connection	49	Rx7n	V-by-One HS Data Lane 7
24	GND	Ground	50	Rx7p	V-by-One HS Data Lane 7
25	HTPDN	Hot plug detec	51	GND	Ground
26	LOCKN	Lock detect			

Pin No	Symbol	Description	Note
1	GND	Ground	
2	GND	Ground	
3	VLCD	Power Supply +12.0V	
4	VLCD	Power Supply +12.0V	
5	VLCD	Power Supply +12.0V	

Note 1: NC (Not Connected) : This pins are only used for BOE internal operations.

Note 2: BIST : This pin is used for selecting display pattern mode when input DE or input CLOCK quits toggling.

### BIST Pattern

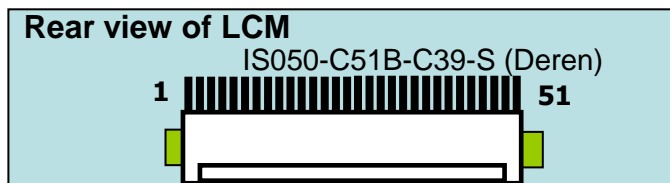

PT1: Black (2 sec)	PT2: White (2 sec)	PT3: Red (2 sec)	PT4: Green (2 sec)	PT5: Blue (2 sec)

SPEC. NUMBER  
S8-65-AA-064

SPEC. TITLE  
DV750QUB-R01 Product Specification REV. P0

PAGE  
13 OF 43

#### 4.2 V by one Misc. Setting.-1 Section

- a) System side have to put pull high resistor on LOCKN/HTPDN pins.
- b) V by one data mapping as follows.

< Table 9. V by one setting & data mapping Table >

1 Section								
Hactive = 3840								
	Port0		Port1		Port2		Port3	
	Lane0	Lane1	Lane2	Lane3	Lane4	Lane5	Lane6	Lane7
V Blanking	FSBS	FSBS	FSBS	FSBS	FSBS	FSBS	FSBS	FSBS
	FSBP	FSBP	FSBP	FSBP	FSBP	FSBP	FSBP	FSBP
	...	...	...	...	...	...	...	...
	FSBP	FSBP	FSBP	FSBP	FSBP	FSBP	FSBP	FSBP
	FSBE_SR	FSBE_SR	FSBE_SR	FSBE_SR	FSBE_SR	FSBE_SR	FSBE_SR	FSBE_SR
Line 1	Pixel 1	Pixel 2	Pixel 3	Pixel 4	Pixel 5	Pixel 6	Pixel 7	Pixel 8
	Pixel 9	Pixel 10	Pixel 11	Pixel 12	Pixel 13	Pixel 14	Pixel 15	Pixel 16
	...	...	...	...	...	...	...	...
	...	...	...	...	...	...	...	...
	Pixel 3833	Pixel 3834	Pixel 3835	Pixel 3836	Pixel 3837	Pixel 3838	Pixel 3839	Pixel 3840
H Blanking	FSBS	FSBS	FSBS	FSBS	FSBS	FSBS	FSBS	FSBS
	FSBP	FSBP	FSBP	FSBP	FSBP	FSBP	FSBP	FSBP
	...	...	...	...	...	...	...	...
	FSBP	FSBP	FSBP	FSBP	FSBP	FSBP	FSBP	FSBP
	FSBE	FSBE	FSBE	FSBE	FSBE	FSBE	FSBE	FSBE
Line 2	Pixel 1	Pixel 2	Pixel 3	Pixel 4	Pixel 5	Pixel 6	Pixel 7	Pixel 8
	Pixel 9	Pixel 10	Pixel 11	Pixel 12	Pixel 13	Pixel 14	Pixel 15	Pixel 16
	...	...	...	...	...	...	...	...
	...	...	...	...	...	...	...	...
	Pixel 3833	Pixel 3834	Pixel 3835	Pixel 3836	Pixel 3837	Pixel 3838	Pixel 3839	Pixel 3840

### 4.3 V by one Misc. Setting.-2 Section

- a) System side have to put pull high resistor on LOCKN/HTPDN pins.
- b) V by one data mapping as follows.

< Table 10. V by one setting & data mapping Table >

2 Section								
Hactive = 3840								
	Port0		Port1		Port2		Port3	
	Lane0	Lane1	Lane2	Lane3	Lane4	Lane5	Lane6	Lane7
V Blanking	FSBS	FSBS	FSBS	FSBS	FSBS	FSBS	FSBS	FSBS
	FSBP	FSBP	FSBP	FSBP	FSBP	FSBP	FSBP	FSBP
	...	...	...	...	...	...	...	...
	FSBP	FSBP	FSBP	FSBP	FSBP	FSBP	FSBP	FSBP
	FSBE_SR	FSBE_SR	FSBE_SR	FSBE_SR	FSBE_SR	FSBE_SR	FSBE_SR	FSBE_SR
Line 1	Pixel 1	Pixel 2	Pixel 3	Pixel 4	Pixel 1921	Pixel 1922	Pixel 1923	Pixel 1924
	Pixel 5	Pixel 6	Pixel 7	Pixel 8	Pixel 1925	Pixel 1926	Pixel 1927	Pixel 1928
	...	...	...	...	...	...	...	...
	...	...	...	...	...	...	...	...
	Pixel 1917	Pixel 1918	Pixel 1919	Pixel 1920	Pixel 3837	Pixel 3838	Pixel 3839	Pixel 3840
H Blanking	FSBS	FSBS	FSBS	FSBS	FSBS	FSBS	FSBS	FSBS
	FSBP	FSBP	FSBP	FSBP	FSBP	FSBP	FSBP	FSBP
	...	...	...	...	...	...	...	...
	FSBP	FSBP	FSBP	FSBP	FSBP	FSBP	FSBP	FSBP
	FSBE	FSBE	FSBE	FSBE	FSBE	FSBE	FSBE	FSBE
Line 2	Pixel 1	Pixel 2	Pixel 3	Pixel 4	Pixel 1921	Pixel 1922	Pixel 1923	Pixel 1924
	Pixel 5	Pixel 6	Pixel 7	Pixel 8	Pixel 1925	Pixel 1926	Pixel 1927	Pixel 1928
	...	...	...	...	...	...	...	...
	...	...	...	...	...	...	...	...
	Pixel 1917	Pixel 1918	Pixel 1919	Pixel 1920	Pixel 3837	Pixel 3838	Pixel 3839	Pixel 3840



### 4.5 Output CNT & FFC Drawing -FFC Drawing

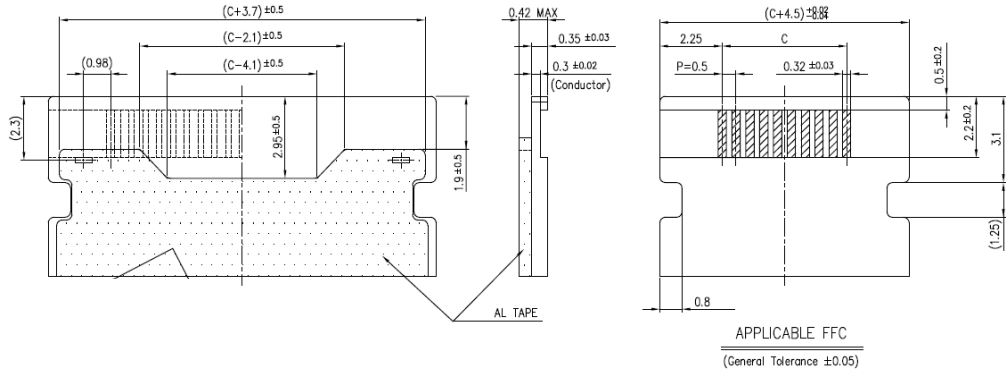

Note 1: This FFC drawing are supplied by the connector vendor.

### -68pin Connector Drawing

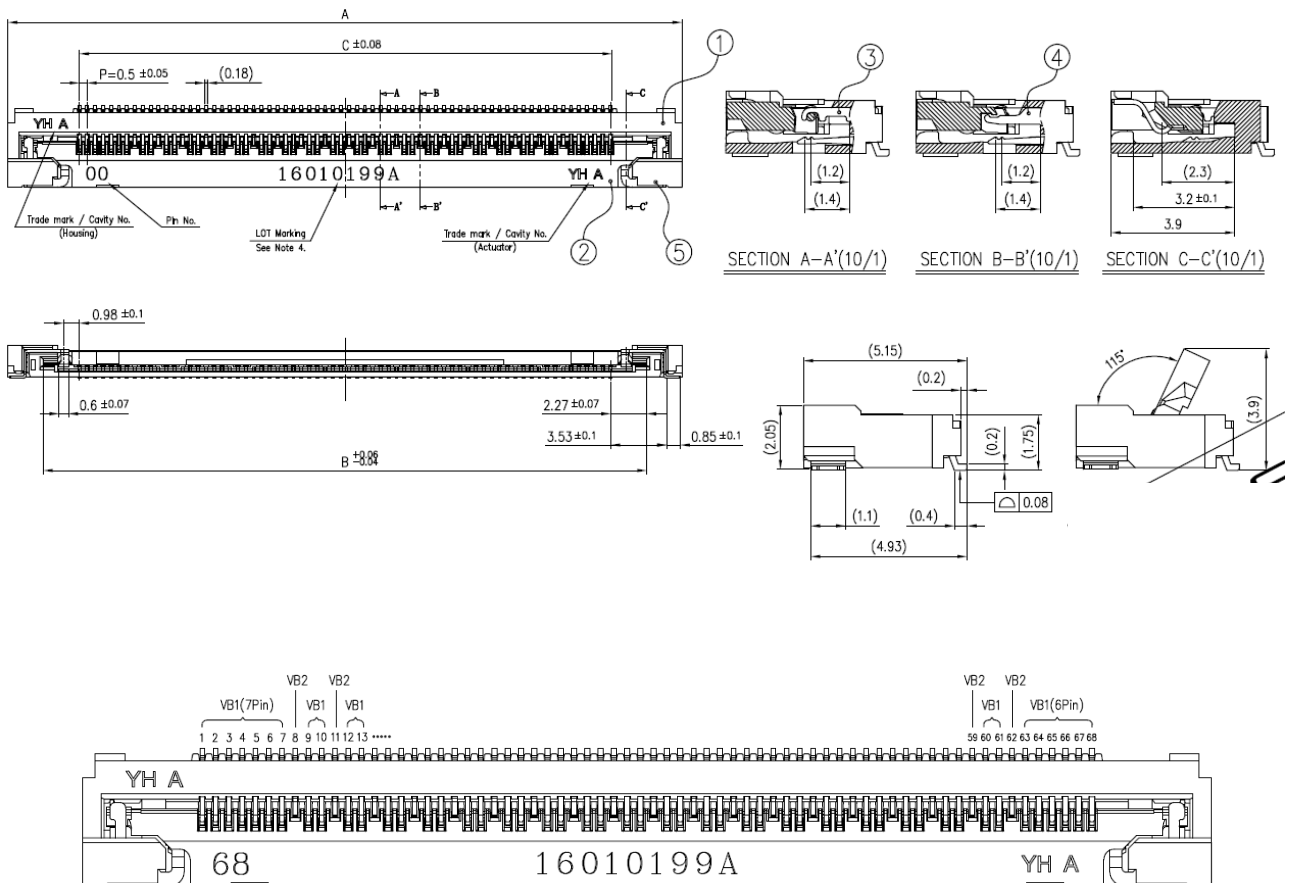



### 5.0 SIGNAL TIMING WAVEFORMS OF INTERFACE SIGNAL

#### 5.1 Input data specification

<Table 11. Vx1 Byte length and Color mapping >

Byte	Packer input	Color data mapping
		30 bpp RGB
0	Bit-0	R2
	Bit-1	R3
	Bit-2	R4
	Bit-3	R5
	Bit-4	R6
	Bit-5	R7
	Bit-6	R8
	Bit-7	R9
1	Bit-8	G2
	Bit-9	G3
	Bit-10	G4
	Bit-11	G5
	Bit-12	G6
	Bit-13	G7
	Bit-14	G8
	Bit-15	G9
2	Bit-16	B2
	Bit-17	B3
	Bit-18	B4
	Bit-19	B5
	Bit-20	B6
	Bit-21	B7
	Bit-22	B8
	Bit-23	B9
3	Bit-24	-
	Bit-25	-
	Bit-26	B0
	Bit-27	B1
	Bit-28	G0
	Bit-29	G1
	Bit-30	R0
	Bit-31	R1

## 6.0 SIGNAL TIMING SPECIFICATION

### 6.1 Timing Parameters

< Table 12. Timing Table >

Item		Symbols	Min	Typ	Max	Unit
Frequency		1/Tc	66	74.25	75	MHz
Vertical	Frame Rate	F	57	60	63	Hz
	Total	T <sub>V</sub>	2180	2250	2450	T <sub>H</sub>
	Display	T <sub>VD</sub>	2160			T <sub>H</sub>
	Blank	T <sub>VB</sub>	40	90	290	T <sub>H</sub>
Horizontal	Total	T <sub>H</sub>	533	550	570	T <sub>CLK</sub>
	Display	T <sub>HD</sub>	-	480	-	T <sub>CLK</sub>
	Blank	T <sub>HB</sub>	53	70	90	T <sub>CLK</sub>

Item		Symbols	Min	Typ	Max	Unit
Frequency		1/Tc	55	61.87	62.5	MHz
Vertical	Frame Rate	F	47	50	53	Hz
	Total	T <sub>V</sub>	2180	2250	2450	T <sub>H</sub>
	Display	T <sub>VD</sub>	2160			T <sub>H</sub>
	Blank	T <sub>VB</sub>	40	90	290	T <sub>H</sub>
Horizontal	Total	T <sub>H</sub>	533	550	570	T <sub>CLK</sub>
	Display	T <sub>HD</sub>	-	480	-	T <sub>CLK</sub>
	Blank	T <sub>HB</sub>	53	70	90	T <sub>CLK</sub>

Note 1: This product is DE only mode. The input of Hsync & Vsync signal does not have an effect on normal operation.

< Table 13. Signal Timing Table >

Parameter	Symbol	Condition	Min	Typ	Max	Unit
Unit Interval(VBO Operation Bit Rate)	tRBIT	3-byte	380	tTCIP/30	1667	PS
		4-byte	285	tTCIP/40	1250	PS
		5-byte	266	tTCIP/50	1000	PS
Eye Width at Package Pin	tREYE	-	-	1	-	UI
Eye Width Position A at Package Pin	tA	-	-	0.25	-	UI
Eye Width Position B at Package Pin	tB	-	-	0.3	-	UI
Eye Width Position Cat Package Pin	tC	-	-	0.7	-	UI
Eye Width Position D at Package Pin	tD	-	-	0.75	-	UI
Eye Width Position E at Package Pin	tE	-	-	0.7	-	UI
Eye Width Position F at Package Pin	tF	-	-	0.3	-	UI
Intra – pair Skew	TTOSK_intra	-	-0.3	-	0.3	UI
Inter – pair Skew	TTOSK_inter	-	-5	-	5	UI
SSCG	-	30KHz modulation	-0.5		0.5	%

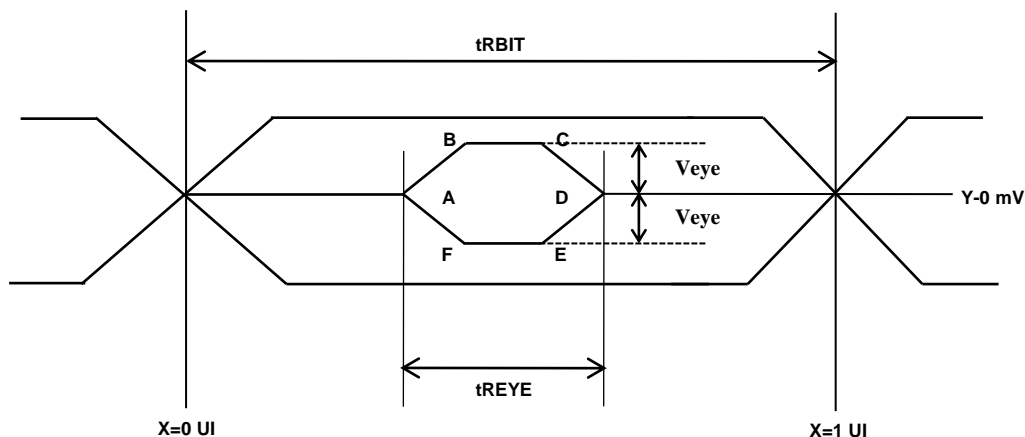



### 6.3 Power Sequence

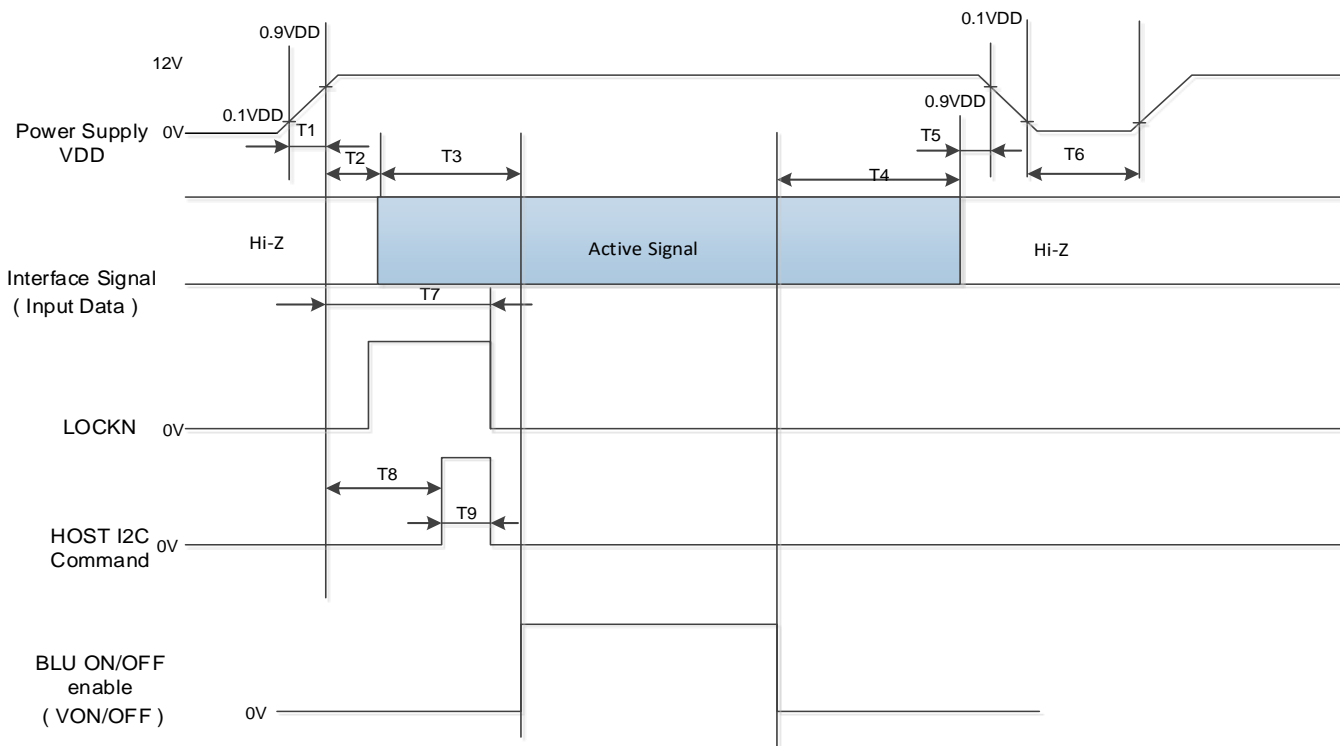

< Table 15. Sequence Table >

Parameter	Values			Units
	Min	Typ	Max	
T1	0.5	-	10	ms
T2	0	-	-	ms
T3	200	-	-	ms
T4	100	-	-	ms
T5	0	-	-	ms
T6	1	-	-	s
T7	-	-	500	ms
T8	1200	-	-	ms
T9	Depends on I2C command			ms

Note 1: Even though T1 is over the specified value, there is no problem if I2T spec of fuse is satisfied.

Note 2: Even though T4 is over the specified value, there is no problem if I2T spec of fuse is satisfied.

Note 3: Back Light must be turn on after power for logic and interface signal are valid.

## 7.0 OPTICAL SPECIFICATION

The test of optical specifications shall be measured in a dark room (ambient luminance $\leq$ 1 lux and temperature $=25\pm 2^{\circ}\text{C}$ ) with the equipment of Luminance meter system (Goniometer system and PR730) and test unit shall be located at an approximate distance 180cm from the LCD surface at a viewing angle of  $\theta$  and  $\Phi$  equal to  $0^{\circ}$ . We refer to  $\theta_{\Phi=0}$  ( $=\theta_3$ ) as the 3 o'clock direction (the "right"),  $\theta_{\Phi=90}$  ( $=\theta_{12}$ ) as the 12 o'clock direction ("upward"),  $\theta_{\Phi=180}$  ( $=\theta_9$ ) as the 9 o'clock direction ("left") and  $\theta_{\Phi=270}$  ( $=\theta_6$ ) as the 6 o'clock direction ("bottom"). While scanning  $\theta$  and/or  $\Phi$ , the center of the measuring spot on the Display surface shall stay fixed. The measurement shall be executed after 30 minutes warm-up period. VDD shall be 12.0V  $\pm$ 10% at  $25^{\circ}\text{C}$ . Optimum viewing angle direction is 6 'clock.

< Table 16. Optical Table >

[VDD = 12.0V, Frame rate = 60Hz, Ta =  $25\pm 2^{\circ}\text{C}$ ]

Parameter		Symbol	Condition	Min	Typ	Max	Unit	Remark
Viewing Angle	Horizontal	$\Theta_3$	CR > 10	-	89	-	Deg.	Note1
		$\Theta_9$		-	89	-	Deg.	
	Vertical	$\Theta_{12}$		-	89	-	Deg.	
		$\Theta_6$		-	89	-	Deg.	
Contrast ratio		CR		800	1200	-		Note2
Reproduction of color	White	$W_x$	$\Theta = 0^{\circ}$ (Center) Normal Viewing Angle	Typ.- 0.03	0.295	Typ.+ 0.03	-	Based on BOE Backlight (Loop4-1 -06A1BB)
		$W_y$			0.312		-	
	Red	$R_x$			0.675		-	
		$R_y$			0.313		-	
	Green	$G_x$			0.271		-	
		$G_y$			0.653		-	
	Blue	$B_x$			0.151		-	
		$B_y$			0.054		-	
Response Time	G to G	$T_g$		-	8	-	ms	-
Gamma Scale				-	2.2	-		$2.2 \pm 0.3$ (50~128 Gray)
Cell Transmittance				4.95	5.5		%	Note 5

**Note :**

1. Viewing angle is the angle at which the contrast ratio is greater than 10. The viewing are determined for the horizontal or 3, 9 o'clock direction and the vertical or 6, 12 o'clock direction with respect to the optical axis which is normal to the LCD surface.
2. Contrast measurements shall be made at viewing angle of  $\theta = 0^\circ$  and at the center of the LCD surface. Luminance shall be measured with all pixels in the view field set first to white, then to the dark (black) state. (See Figure 1 shown in Appendix) Luminance Contrast Ratio (CR) is defined mathematically.

$$CR = \frac{\text{Luminance when displaying a white raster}}{\text{Luminance when displaying a black raster}}$$

3. The color chromaticity coordinates specified in Table 12 shall be calculated from the spectral data measured with all pixels first in red, green, blue and white. Measurements shall be made at the center of the panel. The BLU is used by BOE.
4. Response time Tg is the average time required for display transition by switching the input signal as below table and is based on Frame rate fV =60Hz to optimize. Each time in below table shall be measured by switching the input signal for “any level of gray(bright)” and “any level of gray(dark)”

Measured Response Time	Target																	
	0	15	31	47	63	79	95	111	127	143	159	175	191	207	223	239	255	
Start	0																	
	15																	
	31																	
	47																	
	63																	
	79																	
	95																	
	111																	
	127																	
	143																	
	159																	
	175																	
	191																	
	207																	
	223																	
	239																	
255																		

**5. Definition of Transmittance (T%) :**

Module is with white(L255) signal input

$$\text{Transmittance} = \frac{\text{Luminance of LCD Module}}{\text{Luminance of BLU}} \times 100 \%$$

## 6. GRAY SCALE SPECIFICATION

Gray Level	Luminance [%] (Typ)
L0	0.00%
L1	0.00%
L31	0.97%
L63	4.61%
L127	21.58%
L191	52.95%
L223	74.45%
L254	99.14%
L255	100.00%

Notes : P-Gamma applied the Typical spec.

## 8.0 MECHANICAL CHARACTERISTICS

### 8.1 Dimensional Requirements

Figure 3 (located in Appendix) shows mechanical outlines for the model DV750QUB-R01. Other parameters are shown in Table 17.

< Table 17. Dimensional Parameters >

Parameter	Specification	Unit
Active area	1649.664(H) × 927.936(V)	mm
Pixel pitch	429.6(H) × 429.6(V)	μm
Number of pixels	3840*(RGB)*2160	pixels
Weight	4850(Typ.)	kg

### 8.2 Surface Treatment and Polarizer Hardness

The surface of the LCD has an Low haze coating and a coating to Reduce scratching. The front polarizer hardness is 3H.

**9.0 RELIABILITY TEST**

The Reliability test items and its conditions are shown in below.

< Table 18. Reliability Test Parameters >

No	Test Items	Conditions
1	High temperature storage test	Ta = 80 °C, 500 hrs
2	Low temperature storage test	Ta = -30 °C, 500 hrs
3	High temperature & high humidity operation test	Ta = 80°C,60 %RH, 500hrs
4	High temperature operation test	Ta = 80 °C, 240hrs
5	Low temperature operation test	Ta = -30 °C, 500hrs
6	Thermal shock	Ta = -30 °C ↔ 80 °C (0.5 hr), 100 cycle

Note:

This test condition is based on BOE module.

## 10.0 PRECAUTIONS

Please pay attention to the followings when you use this TFT LCD Panel.

### 10.1 Mounting Precautions

- Use finger-stalls with soft gloves in order to keep display clean during the incoming inspection and assembly process.
- You must mount a Panel using specified mounting holes (Details refer to the drawings)
- You should consider the mounting structure so that uneven force (ex. Twisted stress, Concentrated stress) is not applied to the Panel. And the case on which a Panel is mounted should have sufficient strength so that external force is not transmitted directly to the Panel.
- Do not apply mechanical stress or static pressure on Panel; Abnormal display cause by pressing some parts of Panel during assembly process, do not belong to product failure, the press should be agreed by two sides.
- Determine the optimum mounting angle, refer to the viewing angle range in the specification for each model.
- Do not apply mechanical stress or static pressure on Panel, and avoid impact, vibration and falling.
- Acetic acid type and chlorine type materials for the cover case are not desirable because the former generates corrosive gas of attacking the polarizer at high temperature and the latter causes circuit break by electro-chemical reaction.
- Protection film for polarizer on the Panel should be slowly peeled off before display.
- Be careful to prevent water & chemicals contact the Panel surface.
- You should adopt radiation structure to satisfy the temperature specification.
- Do not touch, push or rub the exposed polarizers with glass, tweezers or anything harder than HB pencil lead. And please do not rub with dust clothes with chemical treatment. Do not touch the surface of polarizer for bare hand or greasy cloth. (Some cosmetics are detrimental to the polarizer.)
- When the surface becomes dusty, please wipe gently with absorbent cotton or other soft materials like chamois soaks with petroleum benzine. Normal-hexane & alcohol is recommended for cleaning the adhesives used to attach front / rear polarizers. Do not use acetone, toluene, because they cause chemical damage to the polarizer.
- Wipe off saliva or water drops as soon as possible. Their long time contact with polarizer causes deformations and color fading..

- This Panel has its circuitry PCB's on the rear side and Driver IC, should be handled carefully in order not to be stressed.
- Avoid impose stress on PCB and Driver IC during assembly process ,Do not drawing, bending, COF package & wire
- Do not disassemble the Panel.

## 10.2 Operating Precautions

- Do not connector or disconnect the cable to/from the Panel at the "Power On" Condition.
- When the Panel is operating, do not lose CLK, ENAB signals. If any one of these signals is lost, the Panel would be damaged.
- Obey the supply voltage sequence. If wrong sequence is applied, the Panel would be damaged.
- Do not allow to adjust the adjustable resistance or switch
- The electrochemical reaction caused by DC voltage will lead to LCD Panel degradation, so DC drive should be avoided.
- The LCD Panels use C-MOS LSI drivers, so customers are recommended that any unused input terminal would be connected to Vdd or Vss, do not input any signals before power is turn on, and ground you body, work/assembly area, assembly equipment to protect against static electricity.
- Do not exceed the absolute maximum rating value. (supply voltage variation, input voltage variation, variation in part contents and environmental temperature, and so on) Otherwise the Panel may be damaged.
- Panel has high frequency circuits. Sufficient suppression to the electromagnetic interference shall be done by system manufacturers. Grounding and shielding methods may be important to minimized the interference.
- Design the length of cable to connect between the connector for back-light and the converter as shorter as possible and the shorter cable shall be connected directly , The long cable between back-light and Converter may cause the Luminance of LED to lower and need a higher startup voltage
- The cables should be as short as possible between System Board and PCB interface.
- Connectors are precision devices to transmit electrical signals, and operators should plug in parallel
- Be careful for condensation at sudden temperature change. Condensation makes damage to polarizer or electrical contacted parts. And after fading condensation, smear or spot will occur.

### 10.3 Electrostatic Discharge Precautions

- Avoid the use work clothing made of synthetic fibers. We recommend cotton clothing or other conductivity-treated fibers.
- Since a Panel is composed of electronic circuits, it is not strong to electrostatic discharge. Make certain that treatment persons are connected to ground through wrist band etc.
- Do not close to static electricity to avoid product damage.
- Do not touch interface pin directly.

### 10.4 Precautions for Strong Light Exposure

- Do not leave the Panel operation or storage in Strong light . Strong light exposure causes degradation of polarizer and color filter.

### 10.5 Precautions for Storage

#### A. Atmosphere Requirement

ITEM	UNIT	MIN	MAX
Storage Temperature	(°C)	5	40
Storage Humidity	(%rH)	40	75
Storage Life	6 months		
Storage Condition	<ul style="list-style-type: none"> <li>• The storage room should be equipped with a dark and good ventilation facility.</li> <li>• Prevent products from being exposed to the direct sunlight, moisture and water.</li> <li>• The product need to keep away from organic solvent and corrosive gas.</li> <li>• Be careful for condensation at sudden temperature change.</li> <li>• Storage condition is guaranteed under packing conditions.</li> </ul>		

#### B. Package Requirement

- The product should be placed in a sealed polythene bag.
- Product Should be placed on the pallet, Which is away from the floor, Be cautions not to pile the product up.
- The polarizer surface should not come in contact with any other object. It is recommended that they be stored in the container in which they were shipped.
- As the original protective film, do not use the adhesive protective film to avoid change of Pol color and characteristic.

## 10.6 Precautions for protection film

- Remove the protective film slowly, keeping the removing direction approximate 30-degree not vertical from panel surface, If possible, under ESD control device like ion blower, and the humidity of working room should be kept over 50%RH to reduce the risk of static charge.
- People who peeled off the protection film should wear anti-static strap and grounded well.

## 10.7 Appropriate Condition for Commercial Display

-Generally large-sized LCD Panels are designed for consumer applications . Accordingly, long-term display like in Commercial Display application, can cause uneven display including image sticking. To optimize Panel's lifetime and function, several operating usages are required.

### 1. Normal operating condition

- Temperature:  $20 \pm 15^{\circ}\text{C}$
- Operating Ambient Humidity :  $55 \pm 20\%$
- Display pattern: dynamic pattern (Real display)
- Well-ventilated place is recommended to set up Commercial Display system

### 2. Special operating condition

#### a. Ambient condition

- Well-ventilated place is recommended to set up Commercial Display system.

#### b. Power and screen save

- Periodical power-off or screen save is needed after long-term display.

c. As the low temperature, the response time is greatly delayed. As the high temperatures (higher than the operating temperature) the LCD Panel may turn black screen. The above phenomenon cannot explain the failure of the display. When the temperature returns to the normal operating temperature, the LCD Panel will return to normal display.

d. When expose to drastic fluctuation of temperature (hot to cold or cold to hot) ,the LCD Panel may be affected; Specifically, drastic temperature fluctuation from cold to hot ,produces dew on the LCD Panel 's surface which may affect the operation of the polarizer and LCD Panel

e. Do not exceed the absolute maximum rating value. (supply voltage variation, input voltage variation, variation in part contents and environmental temperature, and so on) Otherwise the Panel may be damaged.

f. Product reliability and functions are only guaranteed when the product is used under right operation usages. If product will be used in extreme conditions such as high temperature, high humidity, high altitude, special display images, running time, long time operation, outdoor operation, etc. It is strongly recommended to contact BOE for filed application engineering advice. Otherwise, its reliability and function may not be guaranteed. Extreme conditions are commonly found at airports, transit stations, banks, stock market and controlling systems.

3. Operating usages to protect against image sticking due to long-term static display.

a. Suitable operating time: under 20 hours a day.

b. Static information display recommended to use with moving image.

- Cycling display between 5 minutes' information(static) display and 10 seconds' moving image.

c. Background and character (image) color change

- Use different colors for background and character, respectively.

- Change colors themselves periodically.

d. Avoid combination of background and character with large different luminance.

1) Abnormal condition just means conditions except normal condition.

2) Black image or moving image is strongly recommended as a screen save

4. Lifetime in this spec. is guaranteed only when Commercial Display is used according to operating usages.

## 10.8 Other Precautions

### A. LC Leak

- If the liquid crystal material leaks from the panel, it is recommended to wash the LC with acetone or ethanol and then burn it.
- If the liquid crystal material leaks from the panel, it should be kept away from the eyes or mouth. In case of contact with hands, skin or clothes, it has to be washed away thoroughly with soap.
- If LC in mouth, mouth need to be washed, drink plenty of water to induce vomiting and follow medical advice.
- If LC touch eyes, eyes need to be washed with running water at least 15 minutes.

### B. Rework

- When returning the Panel for repair or etc., Please pack the Panel not to be broken. We recommend to use the original shipping packages.

### 11.0 PRODUCT SERIAL NUMBER



MDL ID Naming Rule:

Digit Code	1	2	3	4	5	6	7	8	9	10	11	12	13	14	15	16	17
Code	S	L	S	9	1	6	3	5	9	4	2	0	A	A	0	0	0
Description	Model Code /GBN		Grade	Line	Year		Month	Model Extension Code (Last 4 Digits Of FGCOD)				Serial No 00001-ZZZZZZ					

## 12.0 PACKING

BOE provides the standard shipping container for customers, unless customer specifies their packing information. The standard packing method and Barcode information are shown in below.

### 12.1 Packing Order

Put 1Pcs EPE Pad in the box, then put 1Pcs Panel into the box. 8 pcs panels per box

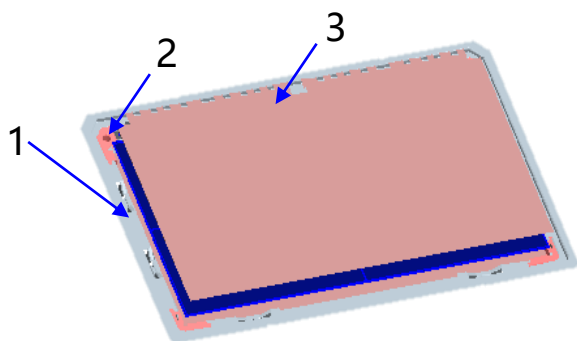

Put the box on the pallet, 7ea boxes per pallet

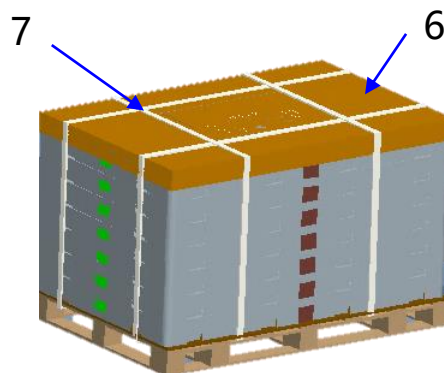
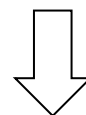
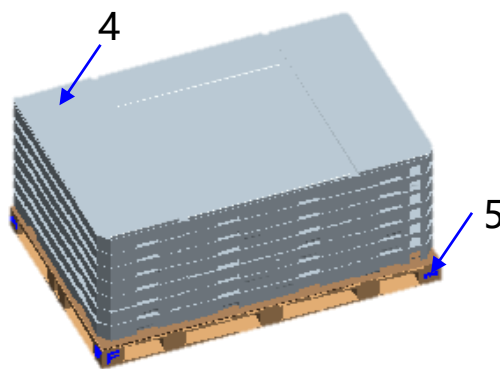

Put totally 7 boxes and 1 cover, then put 1 paper cover and pack with 4 package belts. (7ea boxes per pallet)

N0.	Description	Material
1	Bottom	EPO
2	Cushion	EPP
3	Pad	EPE
4	Cover	EPO
5	Pallet	Wood
6	Paper Cover	Paper
7	Band	PP

### 12.2 Packing Note

- Box Dimension : 1862mm(L)×1228mm(W)×123mm(H)
- Package Quantity in one Box : 8pcs
- Wood Pallet Dimension : 1890mm(L)×1250mm(W)×135mm(H)

### 12.3 Box Label

- Label Size : 110 mm (L) × 55 mm (W)
- Contents

Model : DV750QUB-R01

Q`ty :8 Open Cell in one box.

Serial No. : Box Serial No. See next page for detail description.

Date : Packing Date

FG Code : FG Code of Product

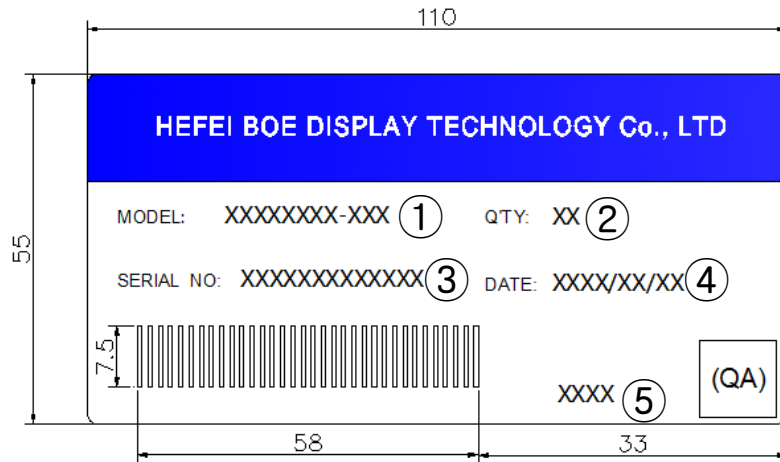

1. FG-CODE(前12位)
2. 包装数量
3. Box ID
4. 包装日期
5. FG-Code后四位

### Box ID Naming Rule:

Digit	1	2	3	4	5	6	7	8	9	10	11	12	13
Code	S	L	S	9	1	6	3	5	9	4	2	0	0
Description	Products GBN		Grade	Line	Year		Month	Revision Code	Serial No 00001- <del>ZZZZZ</del>				

### 12.4 Packing Material ESD Specification

Item	SPEC
Surface Resistance [10 <sup>n</sup> Ω]	Control by 10 <sup>6</sup> ~10 <sup>11</sup> - Box, Spacer, POL Protection film

### 12.5 Pallet Label

- Label Size : 100 mm (L) × 80 mm (W)
- Contents
  - Model : DV750QUB-R01
  - Q`ty : Open Cell quantity in one pallet.
  - Pallet ID: Pallet ID See next for detail description.
  - Date : Packing Date

MODEL : xxxxxxxx-xxx (1)

QTY : xxxx (2)

DATE : 20xx/xx/xx (3) x (4)

PALLET ID : xxxxxxxxxxxx (5) (6)

PALLET ID BAR CODE (7) (QA) (8)

xxxx-xxxxxx (7) xxxxx (8)

1. FG-CODE(The first twelve number)
2. Open Cell quantity in one pallet
3. Pallet Packing Date
4. E:Export/D:Domain
5. Pallet ID
6. QA Mark
7. The Client Product Material No. (No printing)
8. FG-CODE(The last four number)

### PALLET ID Naming Rule:

Digit Code	1	2	3	4	5	6	7	8	9	10	11	12
Code	2	0	1	2	3	F	M	0	0	5	6	7
Description	Year				Month	Line	Pallet Mode	Serial No				

## 13.0 APPENDIX 1

< Figure 1. Measurement Set Up >

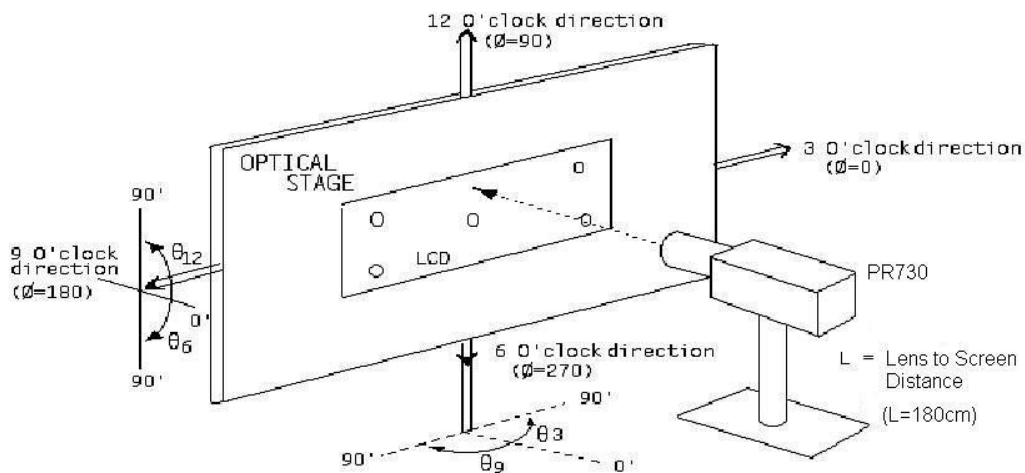

< Figure 2. Response Time Testing >

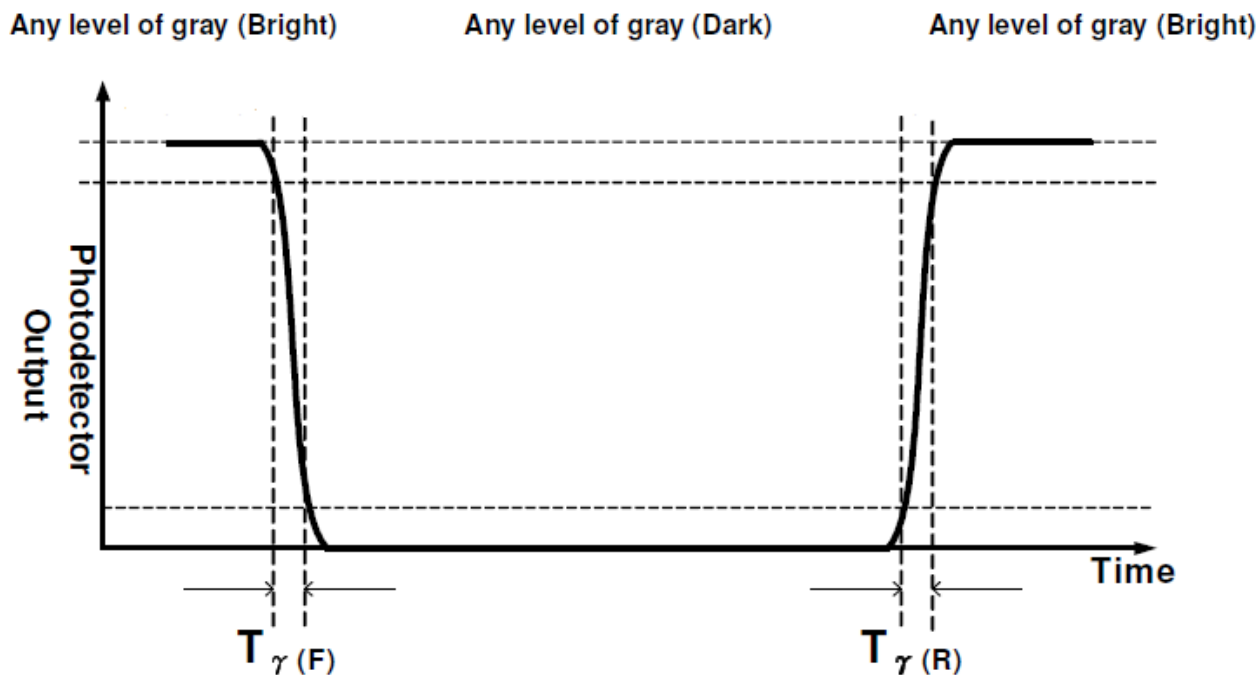

## 13.0 APPENDIX 2

< Figure 3. TFT-LCD Open Cell Outline Dimensions (Front View) >

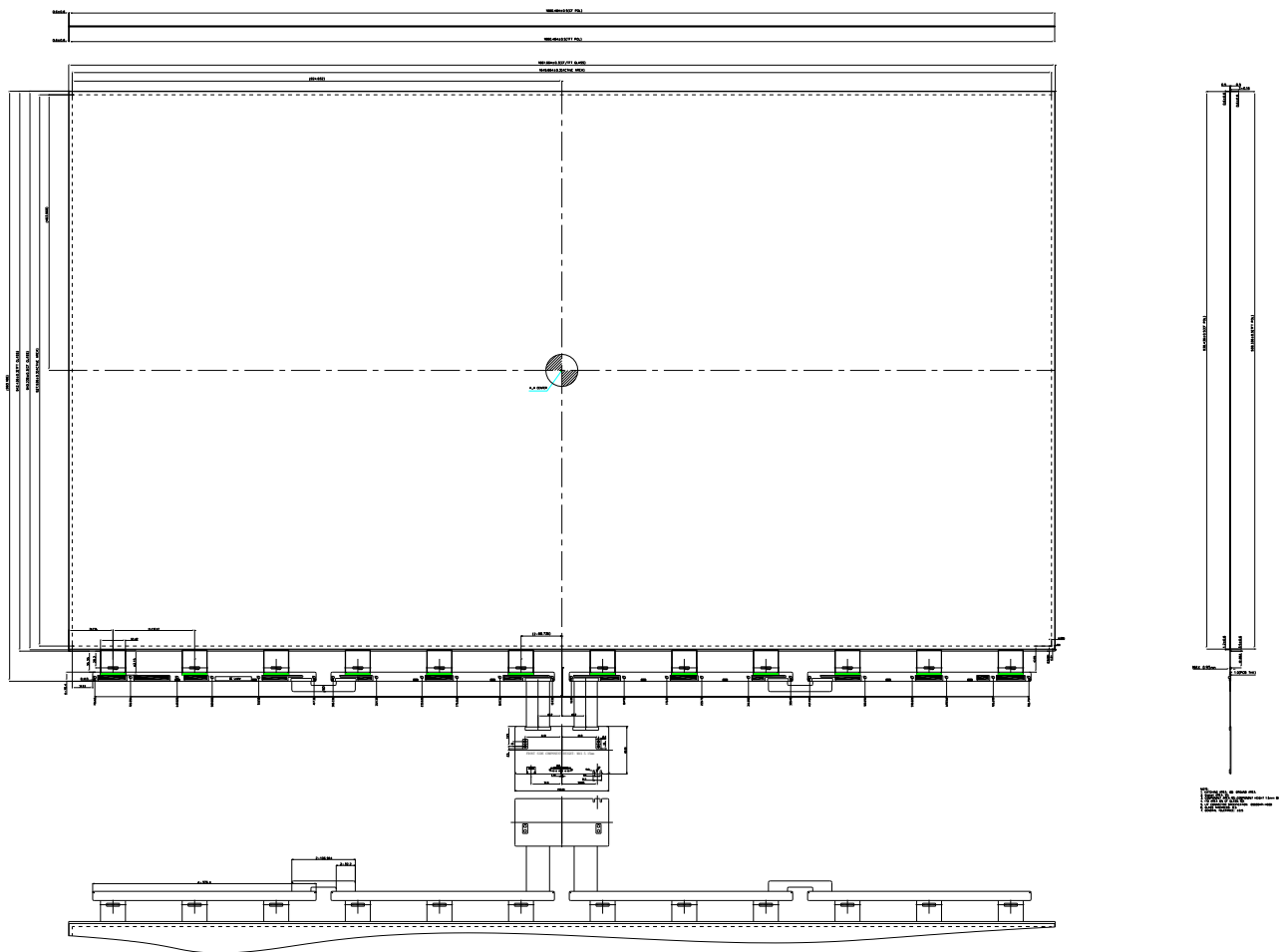

**PANEL SIZE:**  
**TFT-GLASS SIZE:1661.664\*942.436\*0.5T**  
**CF-GLASS SIZE:1661.664\*940.236X0.5T**

TOLERANCE TABLE(±)				
DIMENSION	1 GRADE	2 GRADE	3 GRADE	4 GRADE
L ≤ 20	0.05	0.1	0.1	0.2
20 < L ≤ 50	0.1	0.15	0.2	0.25
50 < L ≤ 100	0.15	0.2	0.25	0.3
100 < L ≤ 200	0.2	0.25	0.3	0.5
200 < L	0.25	0.3	0.5	0.8
UNLESS OTHERWISE SPECIFIED				

**13.0 APPENDIX 3**

< Figure 4. TFT POL Protect Film Peeling Method >

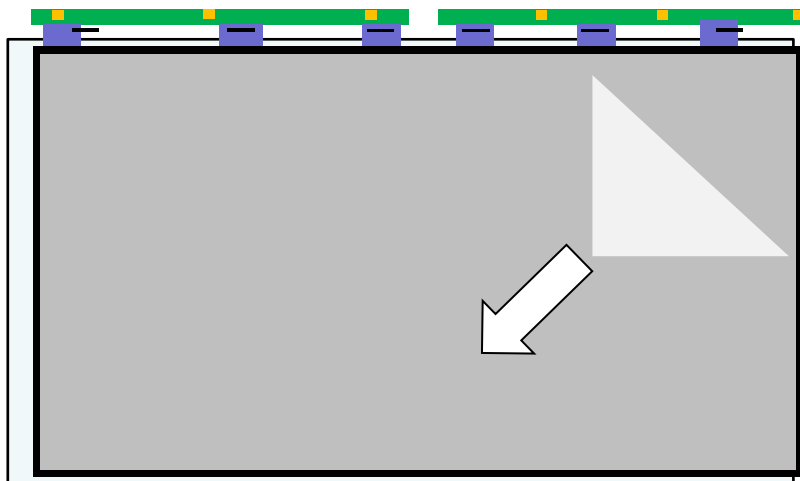

1. Be sure to peel off slowly(recommended more than 7sec) and constant speed.
2. Peeling direction shows in Figure 4.
3. Be sure to ground person with adequate methods such as the anti-static wrist band.
4. Be sure to ground each S-PCB while peeling off the protection film.
5. Ionized air should be blown over during peeling action.
6. The protection film must not touch drivers and S-PWBs.
7. If adhesive may remain on the polarizer after the protection film peeling off, please remove with isopropyl-alcohol.

## 13.0 APPENDIX 4

(a) This Product is Reverse type display Mode

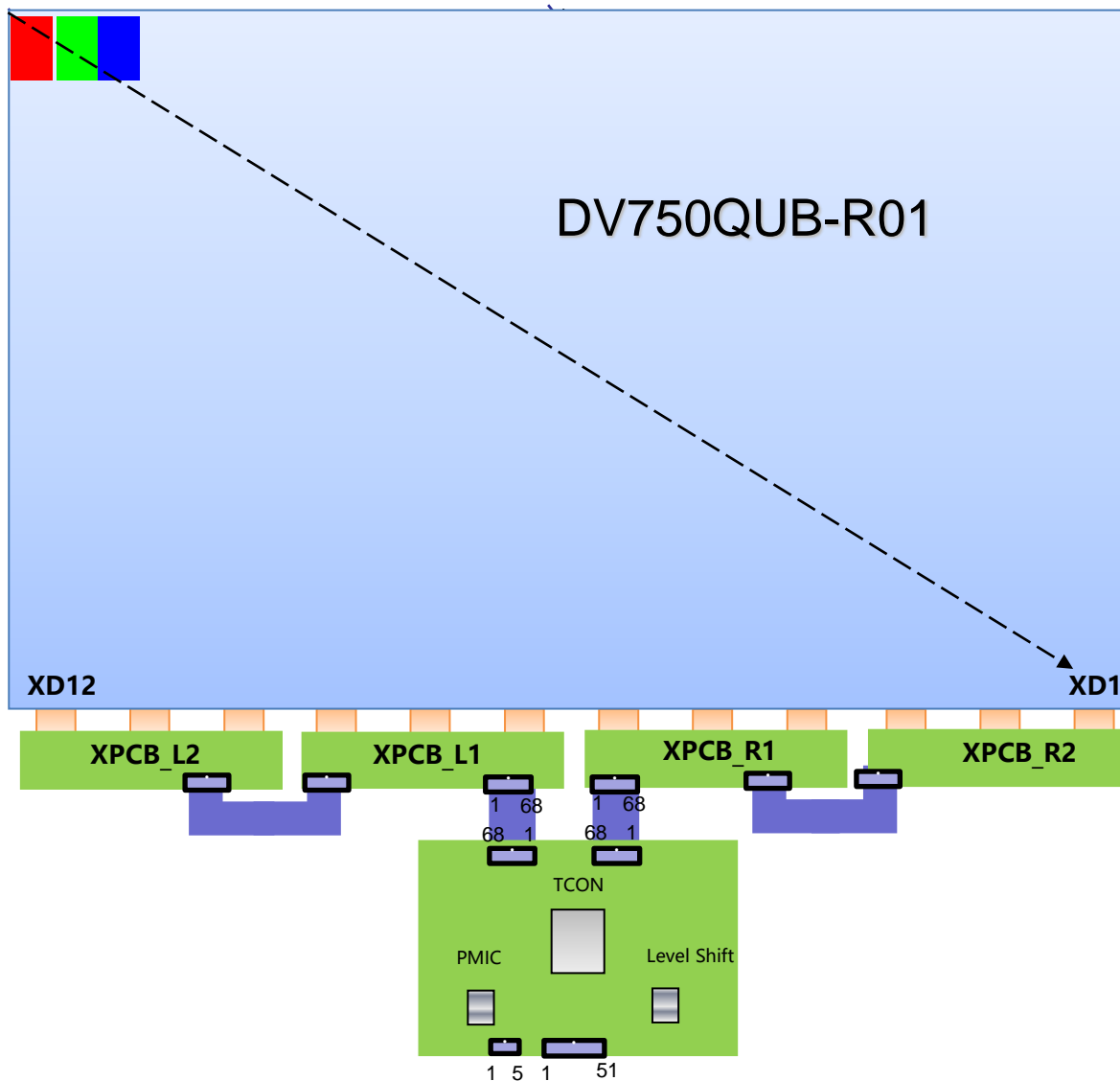

## 13.0 APPENDIX 5

< Table 19. EQ Profile >

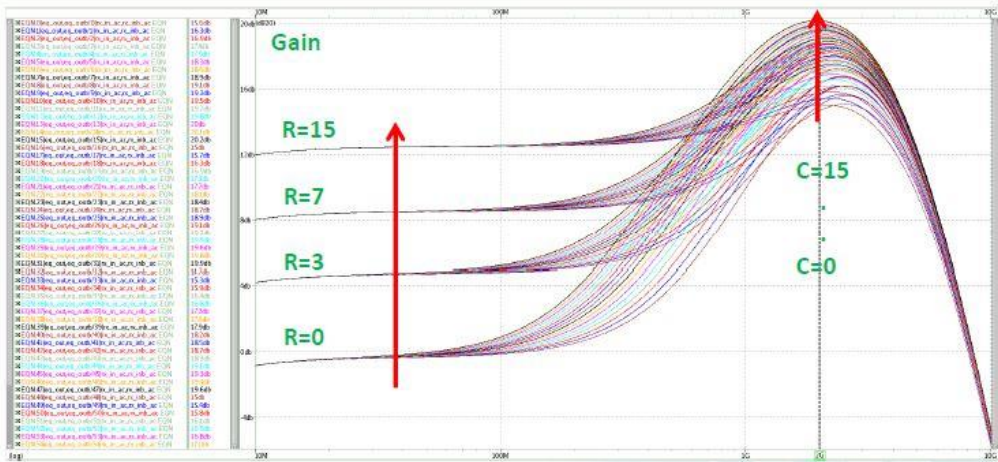

All setting: DC gain (16 step) x peaking (16 step) = 256 steps

< Table 20. SSC Modulation >

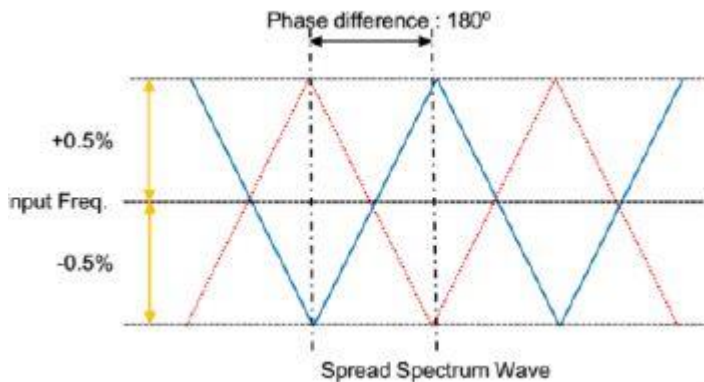

V-by-One supports the maximum amplitude of Spread Spectrum (Tx - 0.5% center spread, 30KHz)

## 13.0 APPENDIX 6 International Standards

### 1. Safety

- a) IEC 60065, The International Electrotechnical Commission (IEC).  
Audio, Video and Similar Electronic Apparatus - Safety Requirements.

### 2. Environment

- a) Directive (EU) 2017/2102 of the European Parliament and of the Council of 15 November 2017
- b) REACH, Regulation (EC) No 1907/2006 of the European Parliament and of the Council of 18 December 2006 concerning the Registration, Evaluation, Authorization and Restriction of Chemicals