



SPECIFICATIONS

CUSTOMER : PTC
SAMPLE CODE (Ver.) : _____
MASS PRODUCTION CODE (Ver.) : PC2004LRS-ANH-H-Q (Ver.0)
DRAWING NO. (Ver.) : PC-95011

Customer Approved

Date: _____

Approved	QC Confirmed	Designer

Approval For Specifications Only.

* This specification is subject to change without notice.

Please contact Powertip or it's representative before designing your product based on this specification.

Approval For Specifications and Sample.

POWERTIP TECH. CORP.

Headquarters: No.8, 6th Road, Taichung Industrial Park,
Taichung, Taiwan
台中市 407 工業區六路 8 號

TEL: 886-4-2355-8168

FAX: 886-4-2355-8166

E-mail: sales@powertip.com.tw

[Http://www.powertip.com.tw](http://www.powertip.com.tw)

Contents

1. SPECIFICATIONS

- 1.1 Features
- 1.2 Mechanical Specifications
- 1.3 Absolute Maximum Ratings
- 1.4 DC Electrical Characteristics
- 1.5 Optical Characteristics
- 1.6 Backlight Characteristics

2. MODULE STRUCTURE

- 2.1 Counter Drawing
- 2.2 Interface Pin Description
- 2.3 Timing Characteristics
- 2.4 Display Command
- 2.5 Character Pattern

3. QUALITY ASSURANCE SYSTEM

- 3.1 Quality Assurance Flow Chart
- 3.2 Inspection Specification

4. RELIABILITY TEST

- 4.1 Reliability Test Condition

5. PRECAUTION RELATING PRODUCT HANDLING

- 5.1 Safety
- 5.2 Handling
- 5.3 Storage
- 5.4 Terms of Warranty

Note : For detailed information please refer to IC data sheet : [NT3381DH,KS0065B](#)

1. SPECIFICATIONS

1.1 Features

Item	Standard Value
Display Type	20 * 4 characters
LCD Type	STN,Gray, Transflective, Positive, Extended Temp.
Driver Type	1/32 Duty , 1/5 Bias
Viewing Direction	6 O'clock
Backlight	Yellow-Green LED B/L
Weight	71.2g
Other	—

1.2 Mechanical Specifications

Item	Standard Value	Unit
Outline Dimension	98.0(L) * 60.0(w) * 13.3(H)(Max)	mm
Viewing Area	76.0(L) * 25.2(w)	mm
Active Area	70.4(L) * 20.8(w)	mm
Dot Size	0.55(L) * 0.55(w)	mm
Dot Pitch	0.60(L) * 0.60(w)	mm

1.3 Absolute Maximum Ratings

Item	Symbol	Condition	Min.	Max.	Unit
Power Supply Voltage	V _{DD}	—	-0.3	7.0	V
LCD Driver Supply Voltage	V _{LCD}	—	V _{DD} -13.5	V _{DD} +0.3	V
Input Voltage	V _{IN}	—	-0.3	V _{DD} +0.3	V
Operating Temperature	T _{OP}	Excluded B/L	-20	70	°C
Storage Temperature	T _{ST}	Excluded B/L	-30	80	°C
Storage Humidity	H _D	T _a < 40 °C	-	90	%RH

1.4 DC Electrical Characteristics

$V_{DD} = 5.0 \text{ V} \pm 10\%$, $V_{SS} = 0\text{V}$, $T_a = 25^\circ\text{C}$

Item	Symbol	Condition	Min.	Typ.	Max.	Unit
Logic Supply Voltage	V_{DD}	—	4.5	5.0	5.5	V
“H” Input Voltage	V_{IH}	—	2.2	-	V_{DD}	V
“L” Input Voltage	V_{IL}	—	-0.3	-	0.8	V
“H” Output Voltage	V_{OH}	$I_{OH} = -0.25\text{mA}$	2.4	-	-	V
“L” Output Voltage	V_{OL}	$I_{OL} = 1.2\text{mA}$	-	-	0.4	V
Supply Current	I_{DD}	$V_{DD} = 5.0 \text{ V}$	-	1.5	3.0	mA
LCM Driver Voltage	V_{OP}	-20°C	-	-	-	V
		$25^\circ\text{C} 1^*$	6.1	6.3	6.5	
		70°C	-	-	-	

Note:1* the Vop test point is Vdd-Vo

1.5 Optical Characteristics

$1/32\text{Duty}$, $1/5\text{Bias}$, $V_{OP} = 8.6\text{V}$, $T_a = 25^\circ\text{C}$

Item	Symbol	Conditions	Min.	Typ.	Max.	Reference
View Angle	θ	$C \geq 2.0, \varnothing = 0^\circ$	15°	-	-	Notes 1 & 2
Contrast Ratio	C	$\theta = 5^\circ, \varnothing = 0^\circ$	2	3	-	Note 3
Response Time(rise)	T_r	$\theta = 5^\circ, \varnothing = 0^\circ$	-	180 ms	270ms	Note 4
Response Time(fall)	T_f	$\theta = 5^\circ, \varnothing = 0^\circ$	-	250 ms	375ms	Note 4

Note 1: Definition of angles θ and ϕ

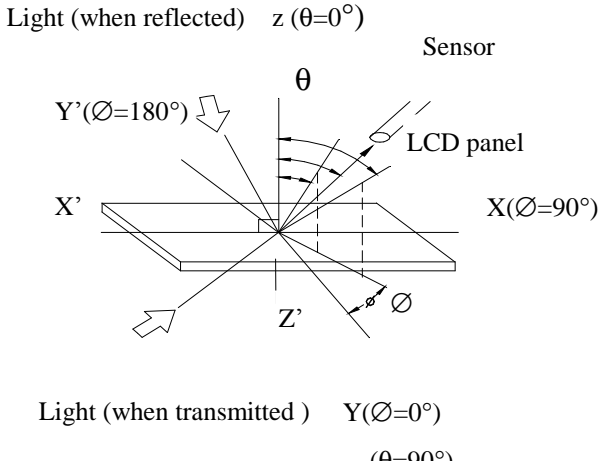

Note 2: Definition of viewing angles θ_1 and θ_2

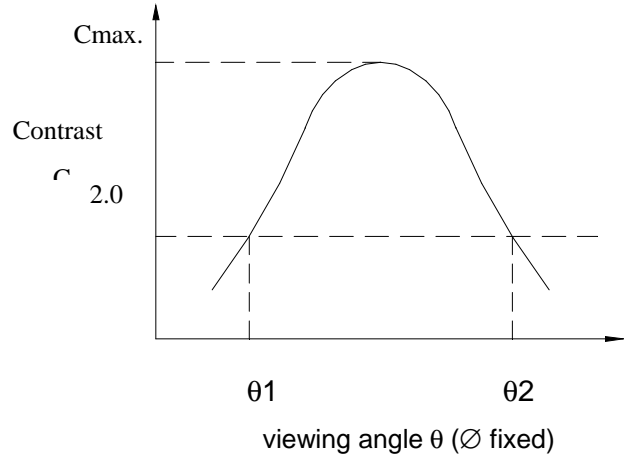

Note : Optimum viewing angle with the naked eye and viewing angle θ at C_{max} . Above are not always the same

Note 3: Definition of contrast C

$$C = \frac{\text{Brightness (reflection) of unselected dot (B2)}}{\text{Brightness (reflection) of selected dot (B1)}}$$

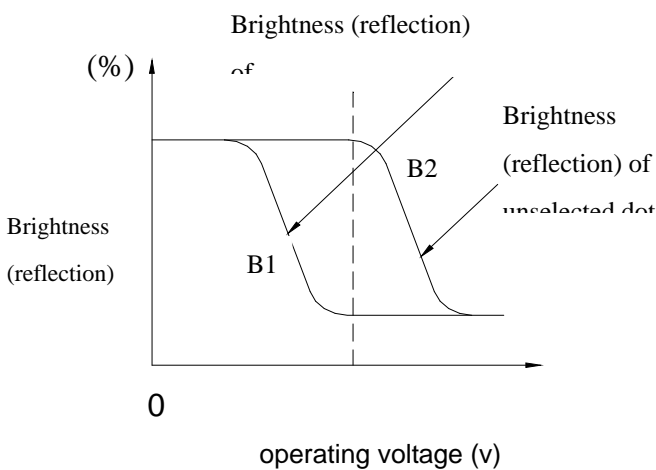

Note 4: Definition of response time

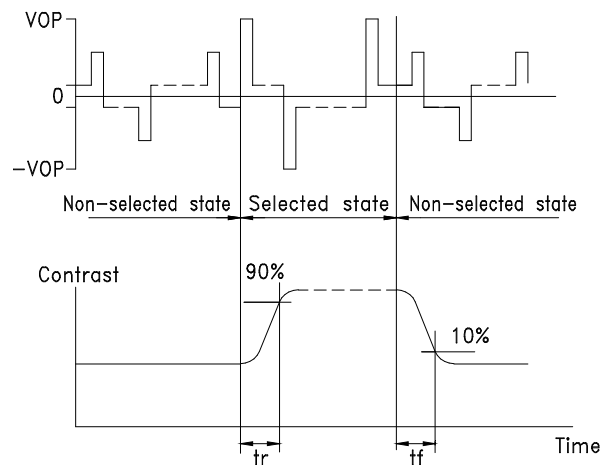

Note: Measured with a transmissive LCD panel which is displayed 1 cm^2

V_{OPR} : Operating voltage

f_{FRM} : Frame frequency

t_r : Response time (rise)

t_f : Response time (fall)

1.6 Backlight Characteristics

LCD Module with LED Backlight

Maximum Ratings

Item	Symbol	Conditions	Min.	Max.	Unit
Forward Current	IF	Ta =25°C	-	650	mA
Reverse Voltage	VR	Ta =25°C	-	8	V
Power Dissipation	PO	Ta =25°C	-	2.99	W
Operating Temperature	T _{OP}	-	-20	70	°C
Storage Temperature	T _{ST}	-	-30	80	°C
Hold temp for 3 Second	-	-	310	330	°C

Electrical Ratings

Ta =25°C

Item	Symbol	Conditions	Min.	Typ.	Max.	Unit
Forward Voltage	V _F	IF=260 mA	-	4.2	4.6	V
Reverse Current	I _R	VR=8V	-	-	0.2	mA
Luminous Intensity (without LCD)	I _V	IF=260 mA	200	250	-	cd/m ²
Wavelength	Hue	IF=260 mA	-	570	-	nm
Color	Yellow-Green					

2. MODULE STRUCTURE

2.1 Counter Drawing

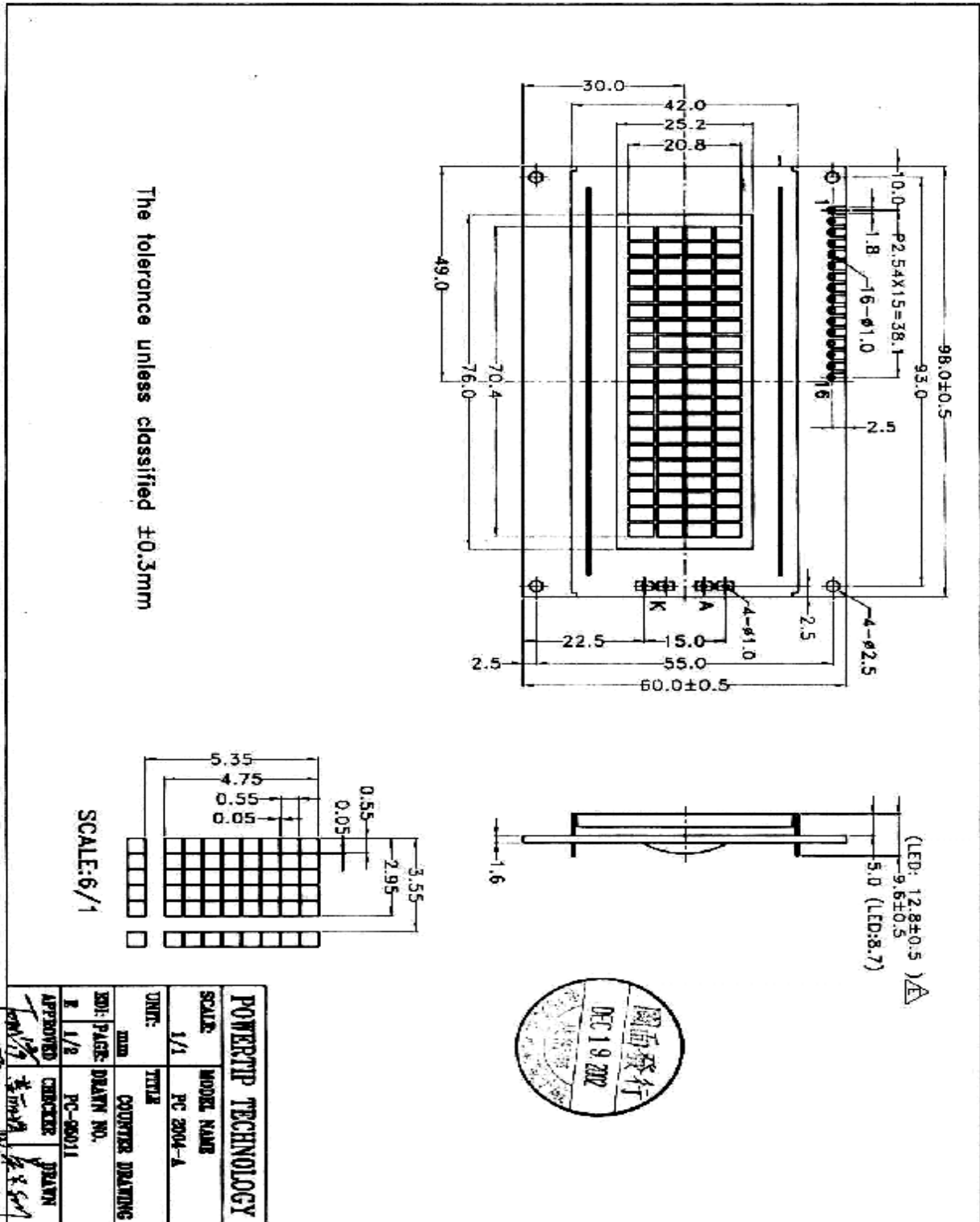

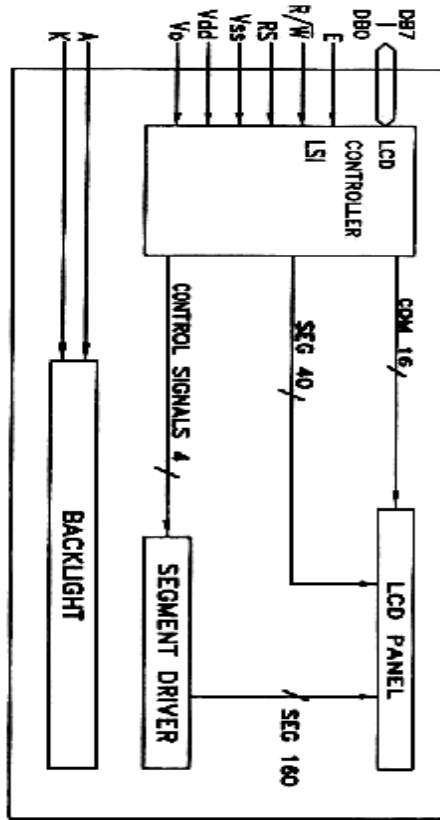

PIN NO.	SIGNAL
1	VSS
2	VDD
3	V0
4	RS
5	R/W
6	E
7	DB0
8	DB1
9	DB2
10	DB3
11	DB4
12	DB5
13	DB6
14	DB7
15	A
16	K

POWERTIP TECHNOLOGY	
SCALE:	MODEL NAME
NO SCALE	PC 2004-A
UNITS:	TITLE
NO UNIT	COMPUTER DRAWING
ZD#: PAGE:	DRAWN NO.
E 2/2	PC-05011
APPROVED:	CHECKER:
PC 1/9	PC 1/9
1999	1999

2.2 Interface Pin Description

Pin No.	Symbol	Signal Description
1	VSS	Power Supply ($V_{SS}=0$)
2	VDD	Power Supply ($V_{DD}>V_{SS}$)
3	VO	Operating voltage for LCD (variable)
4	RS	Register Selection input High = Data register Low = Instruction register (for write) Busy flag address counter (for read)
5	$\overline{R/W}$	Read/Write signal input is used to select the read/write mode High = Read mode, Low = Write mode
6	E	Start enable signal to read or write the data
7~10	DB0 ~ DB3	Four low order bi-directional three-state data bus lines. Used for data transfer between the MPU and the LCD module. These four are not used during 4-bit operation.
11~14	DB4 ~ DB7	Four high order bi-directional three-state data bus lines. Used for data transfer between the MPU and the LCD module. DB7 can be used as a busy flag.
15	A	Power supply for LED B / L (+)
16	K	Power supply for LED B / L (-)

Contrast Adjust

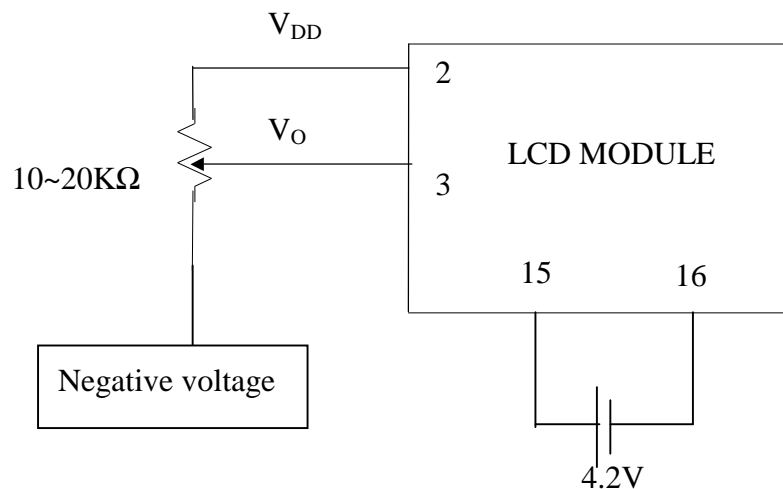

2.3 Timing Characteristics

- Read cycle

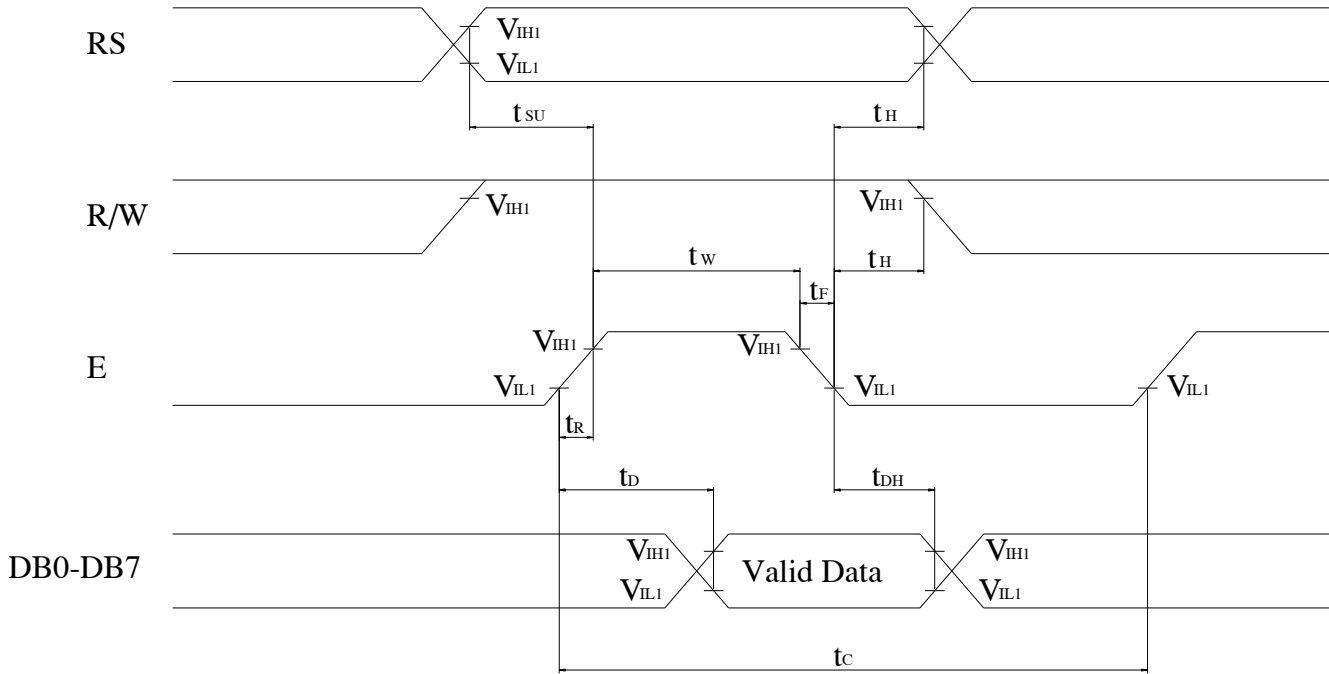

- Write cycle

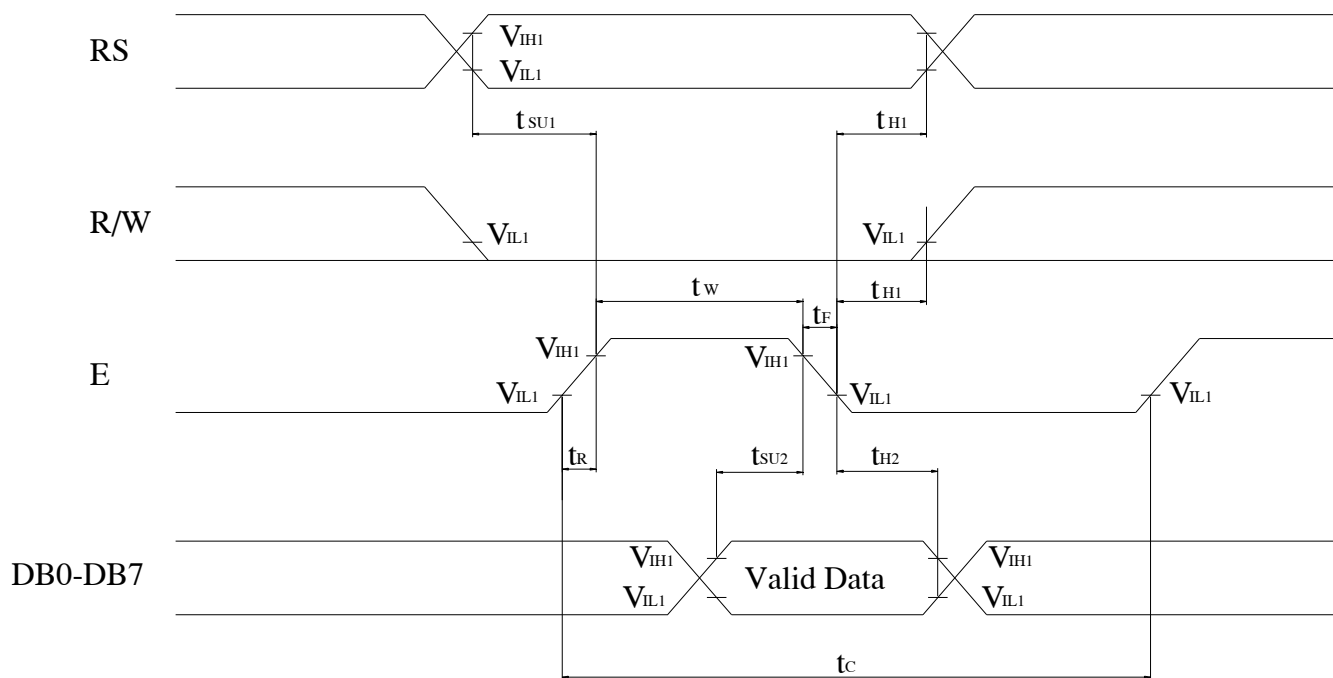

• Read cycle

VDD=5.0V±10%, VSS=0V, Ta=25°C

Characteristics	Symbol	Condition	Min.	Typ.	Max.	Unit
Enable cycle time	t_{CYCE}	-	500	-	-	ns
Enable "H" level pulse width	t_{WEH}	-	300	-	-	ns
Enable rise/fall time	t_{rE}, t_{fE}	-	-	-	25	ns
RS,R/W setup time	t_{AS}	-	60 ¹	-	-	ns
			100 ²			
RS,R/W address hold time	t_{AH}	-	10	-	-	ns
Read data output delay	t_{RD}	$C_L=100pF$	-	-	190	ns
Read data hold time	t_{DHR}		20	-	-	ns

• Write cycle

Characteristics	Symbol	Condition	Min.	Typ.	Max.	Unit
Enable cycle time	t_{CYCE}	-	500	-	-	ns
Enable "H" level pulse width	t_{WEH}	-	300	-	-	ns
Enable rise/fall time	t_{rE}, t_{fE}	-	-	-	25	ns
RS,R/ \overline{W} setup time	t_{AS}	-	60 ¹	-	-	ns
			100 ²			
RS,R/ \overline{W} address hold time	t_{AH}	-	10	-	-	ns
Data setup time	t_{DS}	-	100	-	-	ns
Write data hold time	t_{DH}	-	10	-	-	ns

Notes: 1: 8-bit operation mode

2: 4-bit operation mode

2.4 Display Command

Instructions	Instruction Code										Description	Execution Time(max) ($f_{osc}=250\text{KHZ}$)
	RS	R/W	DB7	DB6	DB5	DB4	DB3	DB2	DB1	DB0		
Clear Display	0	0	0	0	0	0	0	0	0	1	Clear entire display area, restore display from shift, and load address counter with DD RAM address 00H	1.64ms
Display/ Cursor Home	0	0	0	0	0	0	0	0	1	×	Restore display from shift and load address counter with DD RAM address 00H	1.64ms
Entry Mode Set	0	0	0	0	0	0	0	1	I/D	S	Specify direction of cursor movement and display shift mode. This operation takes place after each data transfer (read/write)	40 μ s
Display ON/OFF Control	0	0	0	0	0	0	1	D	C	B	Specify activation of display (D) cursor (C) and blinking of character at cursor position (B).	40 μ s
Display/ Cursor Shift	0	0	0	0	0	1	S/C	R/L	×	×	Shift display or move cursor.	40 μ s
Function Set	0	0	0	0	1	DL	N	F	×	×	Set interface data length (D), number of display line (N), and character font (F).	40 μ s
RAM Address Set	0	0	0	1	ACG						Load the address counter with a CG RAM address. Subsequent data access is for CG RAM data.	40 μ s
DD RAM Address Set	0	0	1	ADD						Load the address counter with a DD RAM address. Subsequent data access is for DD RAM data.	40 μ s	
Busy Flag/Address Counter Read	0	1	AC						Read Busy Flag (BF) and contents of Address Counter (AC).	40 μ s		
CG RAM/DD RAM Data Write	1	0	Write data						Write data to CG RAM or DD RAM.	40 μ s		

CG RAM/DD RAM Data Read	1	1	Read data	Read data from CG RAM or DD RAM	40 μ s
-------------------------------	---	---	-----------	------------------------------------	------------

Note 1: Symbol “*” signifies an insignificant bit (disregards).

Note 2: Correct input value for “N” is predetermined for each model.

2.5 Character Pattern

■ CHARACTER PATTERN(SH/EH,NH)

Upper 4 Bits Lower 4 Bits	LLLL	LLHL	LLHH	LHLL	LHLH	LHHL	LHHH	HLLL	HLLH	HLHL	HLHH	HHLL	HHLH	HHHL	HHHH
LLLL	CG RAM (1)		0	1	2	3	4			5	6	7	8	9	A
LLLH	(2)	!	1	A	Q	a	9			Γ	Я	Ш	ı	ı	ı
LLHL	(3)	"	2	B	R	b	r			È	Ş	ı	ı	ı	ı
LLHH	(4)	#	3	C	S	c	s			Ë	ß	ı	ı	ı	ı
LHLL	(5)	\$	4	D	T	d	t			Ï	ç	ı	ı	ı	ı
LHLH	(6)	%	5	E	U	e	u			Ï	ç	ı	ı	ı	ı
LHHL	(7)	&	6	F	V	f	v			Ï	ç	ı	ı	ı	ı
LHHH	(8)	'	7	G	W	g	w			Ï	ç	ı	ı	ı	ı
HLLL	(1)	0	8	H	X	h	x			Ï	ç	ı	ı	ı	ı
HLLH	(2))	9	I	Y	i	y			Ï	ç	ı	ı	ı	ı
HLHL	(3)	*	:	J	Z	j	z			Ï	ç	ı	ı	ı	ı
HLHH	(4)	+	;	K	[k]			Ï	ç	ı	ı	ı	ı
HHLL	(5)	,	<	L	ç	l	ç			Ï	ç	ı	ı	ı	ı
HHLH	(6)	-	=	M	J	m	j			Ï	ç	ı	ı	ı	ı
HHHL	(7)	.	>	N	^	n	^			Ï	ç	ı	ı	ı	ı
HHHH	(8)	/	?	O	_	o	_			Ï	ç	ı	ı	ı	ı

3. QUALITY ASSURANCE SYSTEM

3.1 Quality Assurance Flow Chart

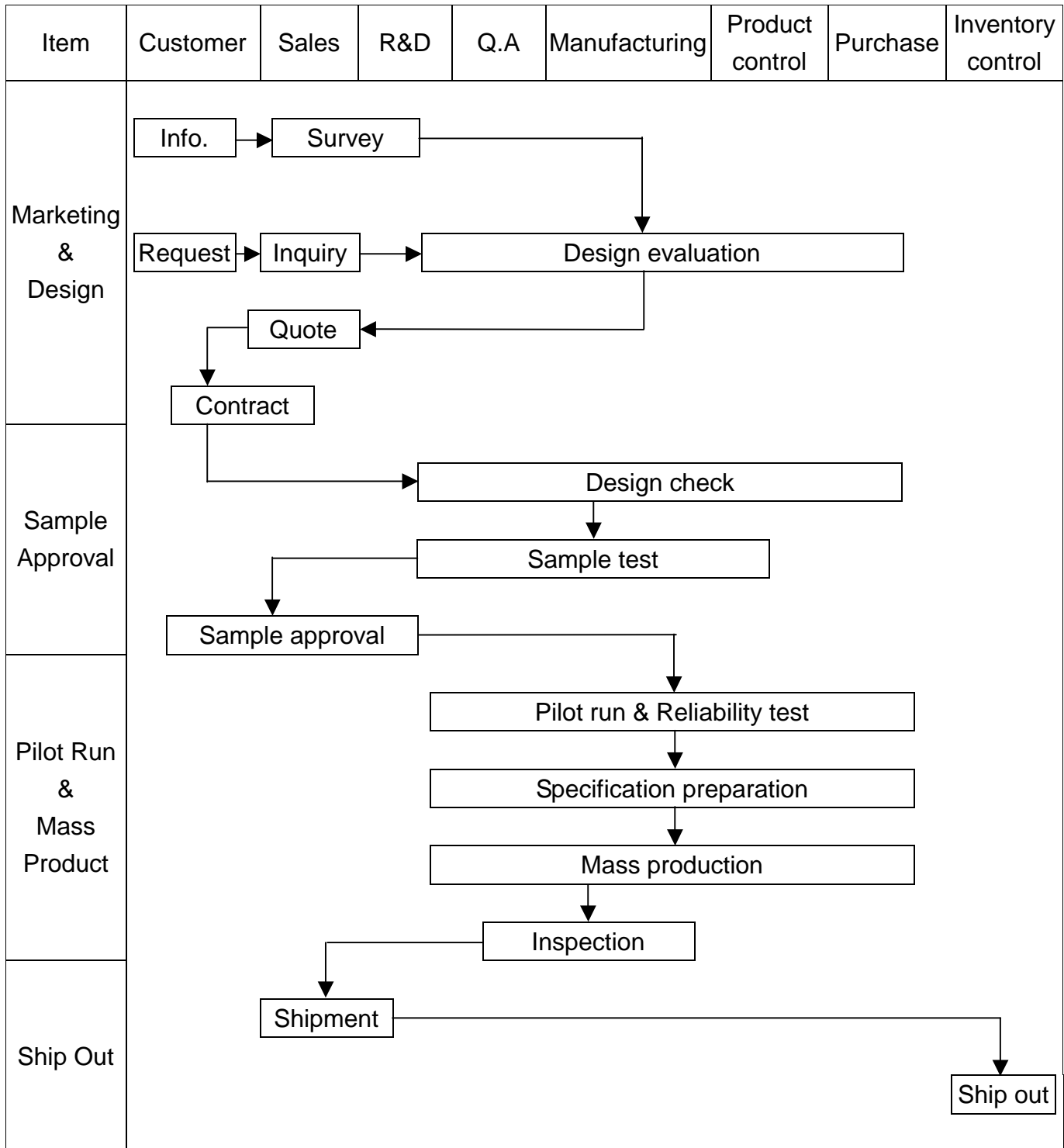

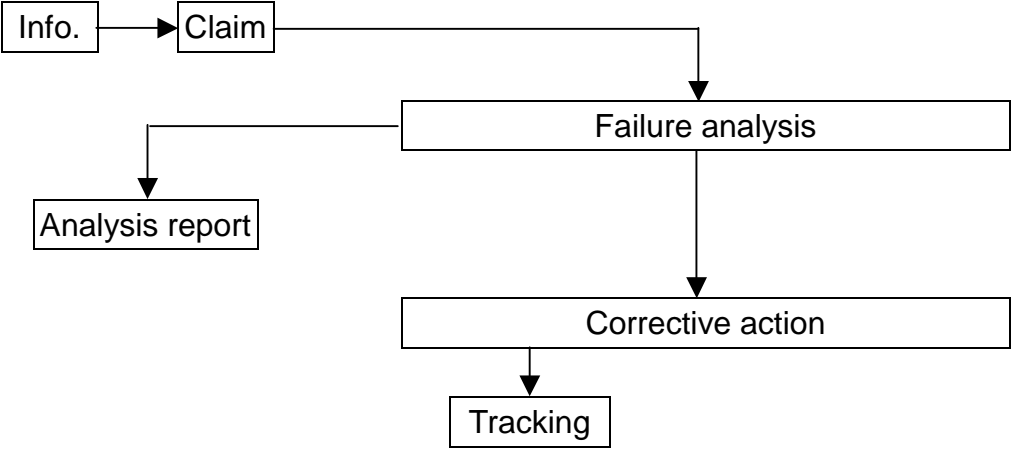
<p>Sales Service</p>	 <pre> graph TD Info[Info.] --> Claim[Claim] Claim --> Failure[Failure analysis] Claim --> Report[Analysis report] Failure --> Action[Corrective action] Action --> Tracking[Tracking] </pre>
<p>Q.A Activity</p>	<p>1. ISO 9001 Maintenance Activities 2. Process improvement proposal 3. Equipment calibration 4. Education And Training Activities 5. Standardization Management</p>

3.2 Inspection Specification

Inspection Standard : MIL-STD-105E Table Normal Inspection Single Sampling Level II ◦

Equipment : Gauge 、 MIL-STD 、 Powertip Tester 、 Sample ◦

IQC Defect Level : Major Defect AQL 0.65; Minor Defect AQL 1.0 ◦

FQC Defect Level : 100% Inspection ◦

OUT Going Defect Level : Sampling ◦

Specification :

N O	Item	Specification	Judge	Level
1	Part Number	Inconsistent with the P/N on the flow chart of production	N.G.	Major
2	Quantity	Inconsistent Q'TY with the flow chart of production	N.G.	Major
3	Electronic characteristics A=(L + W)÷2	Display short	N.G.	Major
		Missing line	N.G.	Major
		Dot missing A > 1/2 Dot size	N.G.	Major
		No function	N.G.	Major
		Out put data error	N.G.	Major
4	Appearance A=(L + W)÷2	Material difference with flow chart	N.G.	Major
		LCD Assembled in opposite direction	N.G.	Major
		Bezel assembled in opposite direction	N.G.	Major
		Shadow within LCD V./A + 1.0 mm	N.G.	Major
		Dirty particle A > 0.4 mm	N.G.	Minor
	Dirty particle (Include scratch 、 bubble)	Dirty particle length > 3.0mm And 0.01mm < Width ≤ 0.05mm (Width > 0.05mm Measure by area)	N.G.	Minor
		Without protective film	N.G.	Minor
		Conductive rubber over bezel	N.G.	Minor
5	PCB Appearance A=(L + W)÷2	Burned PCB	N.G.	Major
		Green paint stripped & visible circuit A > 1.0mm (Finish coat not counted in)	N.G.	Minor
		A particle across the circuit	N.G.	Minor
		Circuit split > 1/2 Circuit width	N.G.	Minor
		Any circuit risen	N.G.	Minor
		0.2mm < Tin ball area A ≤ 0.4mm And Q'TY > 4 Pieces	N.G.	Minor
		Tin ball area A > 0.4mm	N.G.	Minor

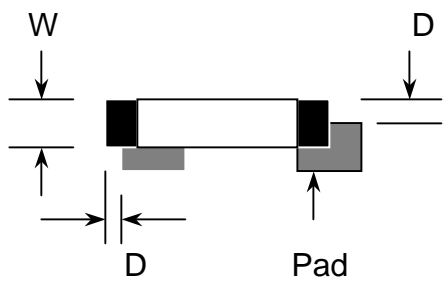
N O	Item	Specification	Judge	Level	
6	Molding appearance $A=(L+W)\div 2$	Too soft : Shape by touch changed	N.G.	Major	
		Insufficient epoxy : IC circuit or IC pad visible	N.G.	Minor	
		Excessive epoxy : Diameter $> 20\text{mm}$ Or High $> 2.5\text{mm}$	N.G.	Minor	
		Pin hole through to IC and $A > 0.2\text{mm}$	N.G.	Minor	
7	Bezel appearance $A=(L+W)\div 2$	Angle between frame and TAB $> 45^\circ + 10^\circ$	N.G.	Minor	
		Electroplate strip $A > 1.0\text{mm}$ (Top view only)	N.G.	Minor	
		Rust (Top view only)	N.G.	Minor	
		Crack	N.G.	Minor	
8	Backlight electric characteristics $A=(L+W)\div 2$	Error backlight color	N.G.	Major	
		No function	N.G.	Major	
		Any LED dot no function	N.G.	Major	
		PIN soldering without tin $A > 1/2$ solder pad	N.G.	Minor	
		Solder PIN high $> 1.5\text{mm}$	N.G.	Minor	
9	LCD Appearance $A=(L+W)\div 2$	Polarize rise over V/A	N.G.	Minor	
10	Assembly parts $A=(L+W)\div 2$	Components mark unclearly	N.G.	Minor	
		Components' distance more than 0.7mm firm the PCB	N.G.	Minor	
		Error position ,not in center $D > 1/4W$		N.G.	Minor
		Non- solder area $>$ Twice solder area			
		Flux area $A > 1/4$ solder area			
		Component broken	N.G.	Minor	

4. RELIABILITY TEST

4.1 Reliability Test Condition

NO	Item	Test Condition		Applicable Standard
1	High Temperature Storage	Storage At $80 \pm 2^{\circ}\text{C}$ 96~100 hrs Surrounding Temperature , Then Storage At Normal Condition 4hrs.		MIL-202E
2	Low Temperature Storage	Storage At $-30 \pm 2^{\circ}\text{C}$ 96~100 hrs Surrounding Temperature, Then Storage At Normal Condition 4hrs.		MIL-202E
3	High Temperature Humidity Storage	1.Storage 96~100 hrs $60 \pm 2^{\circ}\text{C}$, 90~95%RH Surrounding Temperature, Then Storage At Normal Condition 4hrs .(Polarizer may fail in this environment). or 2.Storage 96~100 hrs $40 \pm 2^{\circ}\text{C}$, 90~95%RH Surrounding Temperature, Then Storage At Normal Condition 4 hrs.		MIL-202E
4	Temperature Cycling	$-20^{\circ}\text{C} \rightarrow 25^{\circ}\text{C} \rightarrow 70^{\circ}\text{C} \rightarrow 25^{\circ}\text{C}$ (30Mins) (5Mins) (30Mins) (5Mins) 10 Cycle		MIL-202E
5	Vibration	10~55Hz (1 Minute) 1.5mm X,Y And Z Direction * (Each 2hrs)		MIL-202E
6	Drop Test	Packing Weight (Kg)	Drop High (Cm)	MIL-810E
		0 ~ 45.4	122	
		45.4 ~ 90.8	76	
		90.8 ~ 454	61	
		Over 454	46	

5. PRECAUTION RELATING PRODUCT HANDLING

5.1 SAFETY

- 5.1.1 If the LCD panel breaks , be careful not to get the liquid crystal to touch your skin.
- 5.1.2 If the liquid crystal touches your skin or clothes , please wash it off immediately by using soap and water.

5.2 HANDLING

- 5.2.1 Avoid any strong mechanical shock which can break the glass.
- 5.2.2 Avoid static electricity which can damage the CMOS LSI—When working with the module , be sure to ground your body and any electrical equipment you may be using.
- 5.2.3 Do not remove the panel or frame from the module.
- 5.2.4 The polarizing plate of the display is very fragile. So , please handle it very carefully , do not touch , push or rub the exposed polarizing with anything harder than an HB pencil lead (glass , tweezers , etc.)
- 5.2.5 Do not wipe the polarizing plate with a dry cloth , as it may easily scratch the surface of plate.
- 5.2.6 Do not touch the display area with bare hands , this will stain the display area.
- 5.2.7 Do not use ketonics solvent & aromatic solvent. Use with a soft cloth soaked with a cleaning naphtha solvent.
- 5.2.8 To control temperature and time of soldering is $320\pm 10^{\circ}\text{C}$ and 3-5 sec.
- 5.2.9 To avoid liquid (include organic solvent) stained on LCM .

5.3 STORAGE

- 5.3.1 Store the panel or module in a dark place where the temperature is $25^{\circ}\text{C} \pm 5^{\circ}\text{C}$ and the humidity is below 65% RH.
- 5.3.2 Do not place the module near organics solvents or corrosive gases.
- 5.3.3 Do not crush , shake , or jolt the module.

5.4 TERMS OF WARRANTY

5.4.1 Applicable warrant period

The period is within thirteen months since the date of shipping out under normal using and storage conditions.

5.4.2 Unaccepted responsibility

This product has been manufactured to your company's specification as a part for use in your company's general electronic products. It is guaranteed to perform according to delivery specifications. For any other use apart from general electronic equipment , we cannot take responsibility if the product is used in medical devices , nuclear power control equipment , aerospace equipment , fire and security systems or any other applications in which there is a direct risk to human life and where extremely high levels of reliability are required.