

TENTATIVE

All information in this technical data sheet is tentative
and subject to change without notice.

Preliminary

7.0" WXGA

TECHNICAL SPECIFICATION

AA070TA01ADA11

MITSUBISHI ELECTRIC CORPORATION

Date: Dec. 4,'18

CONTENTS

No.	Item	Page
--	COVER	1
--	CONTENTS	2
1	APPLICATION	3
2	OVERVIEW	4
3	ABSOLUTE MAXIMUM RATINGS	5
4	ELECTRICAL CHARACTERISTICS	5, 6, 7, 8, 9
5	INTERFACE PIN CONNECTION	10, 11, 12, 13
6	INTERFACE TIMING	14, 15, 16, 17, 18, 19
7	BLOCK DIAGRAM	20
8	MECHANICAL SPECIFICATION	21, 22, 23
9	OPTICAL CHARACTERISTICS	24, 25, 26
10	RELIABILITY TEST CONDITION	27
11	OTHER FEATURE	28
12	HANDLING PRECAUTIONS FOR TFT-LCD MODULE	29, 30, 31

1. APPLICATION

This specification applies to color TFT-LCD module, AA070TA01ADA11.

These specification papers are the proprietary product of Mitsubishi Electric Corporation (“MITSUBISHI”) and include materials protected under copyright of MITSUBISHI. No part of this document may be reproduced in any form or by any means without the express written permission of MITSUBISHI.

MITSUBISHI does not assume any liability for infringement of patents, copyrights or other intellectual property rights of third parties by or arising from use of a product specified in this document. No license, express, implied or otherwise, is granted under any patents, copyrights or other intellectual property rights of MITSUBISHI or of others.

MITSUBISHI’s TFT-LCD module is designed and produced for “General Application” which is described as below.

<General Application>

Computers, office automation equipment, factory automation equipment, test and measurement equipment, communications, medical equipment which has no impact for human life and body, display equipment utilized in transportation system (automobiles, ships, trains, etc) which has no influence on its operation directly or indirectly.

Therefore, MITSUBISHI do not guarantee using our TFT-LCD for other application such as medical equipment, safety equipment, transportation system which might be influenced for its operation because of TFT-LCD, military systems, defense equipment, aerospace equipment, nuclear reactor control systems, and any other application in which there is a direct or indirect risk for human life and body or where high levels of reliability are required. Please confirm your application before using MITSUBISHI’s TFT-LCD.

Furthermore, it is mandatory to make contract (document base) by both parties (customer and MITSUBISHI), in case if customers intend to use our TFT-LCD for such application as military systems, defense equipment, aerospace equipment and nuclear reactor control systems, “which has significant impact for human life and body”. Otherwise, please do not use MITSUBISHI’s TFT-LCD for any cases.

MITSUBISHI has been making continuous effort to improve the reliability of its products. However customers should implement sufficient reliability design of their application equipments such as redundant system design, fail-safe functions and anti-failure features.

MITSUBISHI assumes no responsibility for any damage, including but not limited to damage to human life and body, resulting from the use of the product for the application other than the above mentioned General Application or the use of the product that does not comply with the instructions and the precautions specified in this document.

2. OVERVIEW

AA070TA01ADA11 is 7.0" color TFT-LCD (Thin Film Transistor Liquid Crystal Display) module composed of LCD panel, driver ICs, control circuit, LED driver, backlight unit, touch panel, and cover glass.

General specifications are summarized in the following table:

ITEM		SPECIFICATION
Display Area (mm)		151.68 (H) × 91.01 (V) (7.0-inch diagonal)
Number of Dots		1280 × 3(H) × 768(V)
Pixel Pitch (mm)		0.1185 (H) × 0.1185 (V)
Color Pixel Arrangement		RGB vertical stripe
Display Mode		Normally black
Number of Color		262k(6 bit/color), 16.7M(8 bit/color)
Luminance (cd/m ²)		(800)
Viewing Angle (CR ≥ 10)		(-88~88°) (H), (-88~88°) (V)
Cover Glass	Cover Glass Surface	Clear
	Thickness (mm)	1.1
	Glass Type	Strengthened glass
	Surface Hardness	6H
Electrical Interface		LVDS (6 bit/8 bit)
Module Size (mm)		189.8 (W) × 129.7 (H) × 13.7 (D)
Module Mass (g)		(350)
Backlight Unit		LED, edge-light
Touch Panel		Projective capacitive
Multi Touch Points		Max. 10 points
Touch Panel Interface		USB

Characteristic value without any note is typical value.

3. ABSOLUTE MAXIMUM RATINGS

ITEM	SYMBOL	MIN.	MAX.	UNIT
Power Supply Voltage for LCD	VCC	-0.3	4.0	V
Logic Input Voltage	VI	-0.3	VCC+0.3	V
LVDS Input Voltage	VDD_LVDS	-0.3	5.0	V
Backlight Power Supply Input Voltage	VL	-0.3	(14.0)	V
Backlight ON-OFF	BLEN	-0.3	(14.0)	V
Light Dimming Control (PWM) Input Voltage	V _{PDIM}	-0.3	(14.0)	V
Touch Panel Voltage	VDD5	0	6.0	V
Touch Panel Input Voltage	VI _{TP}	-0.3	VDD5+0.3	V
Operation Temperature <small>Note 1,2)</small>	T _{op}	(-30)	(70)	°C
Storage Temperature <small>Note 2)</small>	T _{stg}	(-30)	(80)	°C

[Note]

1) MIN.: Measured at the center of panel surface, MAX.: Measured at the center of panel back surface

2) Top, T_{stg} ≤ 40°C : 90%RH max. without condensation

Top, T_{stg} > 40°C : Absolute humidity shall be less than the value of 90%RH at 40°C without condensation.

4. ELECTRICAL CHARACTERISTICS

(1) TFT-LCD

Ambient temperature: Ta = 25°C

ITEM	SYMBOL	MIN.	TYP.	MAX.	UNIT	Remarks	
Power Supply Voltages for LCD	VCC	3.0	3.3	3.6	V	*1)	
Power Supply Currents for LCD	ICC	--	(260)	(600)	mA	*2)	
LVDS Differential Voltage	VID	0.2	0.4	0.6	V	*3)	
LVDS Differential Common Voltage	VCM	0.6	1.2	2.4 - VID /2	V	*3)	
LVDS H Threshold Voltage	VTH	--	--	100	mV	*3)	
LVDS L Threshold Voltage	VTL	-100	--	--	mV	*3)	
Permissive Input Ripple Voltage	VRP	--	--	(100)	mVp-p	VCC = +3.3V	
Logic Input Voltage	High	VIH	0.8×VCC	--	VCC	V	MODE, SC
	Low	VIL	0	--	0.2×VCC	V	MODE, SC

*1) Power and signals sequence:

0.1 ms ≤ t1 ≤ (3) ms	200 ms ≤ t4
(10) ms ≤ t2 ≤ (100) ms	200 ms ≤ t5
(35) ms ≤ t3 ≤ (100) ms	0 ≤ t6

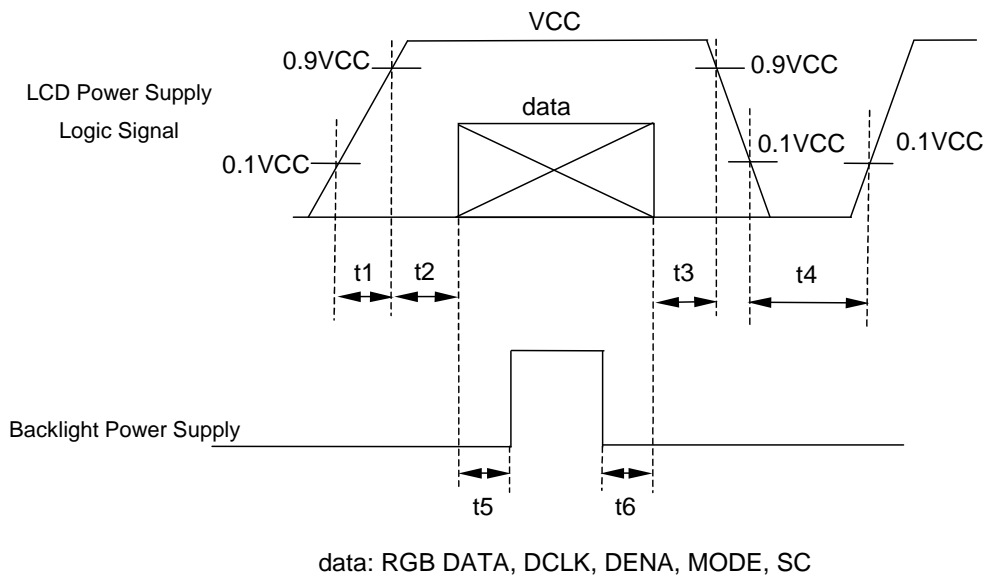

VCC-dip conditions:

When $VCC < 2.6\text{ V}$ or $VCC < 3.0\text{ V}$ and $10\text{ms} < t_d$, this product may not work normally. Please reset power supply according to the power and signals sequence (see 4.(1)*1)).

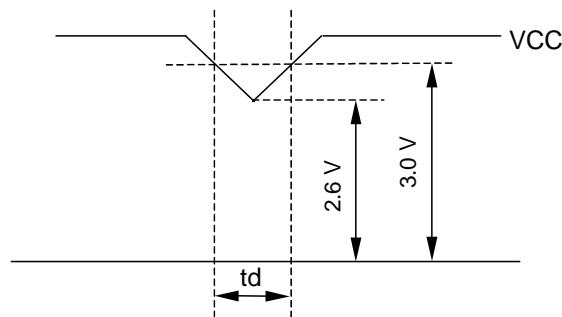

*2) $VCC = +3.3\text{ V}$, $f_H=47.9\text{ kHz}$, $f_V=60\text{ Hz}$, $f_{CLK}=62.8\text{ MHz}$

Display image at typical power supply current value is 256-gray-bar pattern (8 bit).

***3) Definition of LVDS DC Voltage Characteristics**

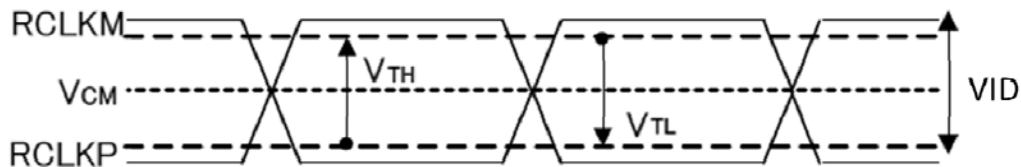

***4) Fuse**

Parameter	Fuse Type Name	Supplier	Remark
VCC	FCC16162AB	Kamaya Electric Co., Ltd.	*)

*) The power supply capacity should be designed to be more than the fusing current.

(2) Backlight

Ta=25°C

ITEM	SYMBOL	MIN.	TYP.	MAX.	UNIT	Remarks	
Power Supply Input Voltage	VL	10.8	12.0	13.2	V	*1)	
Power Supply Input Current	IL	--	(380)	(470)	mA	Dimming=100% VL=12.0V	
Power Supply Input Current (Rush Current)	ILR	--	--	TBD	mA	*2), VL=12.0V	
Backlight ON-OFF	High	BLEN	(2.5)	--	(VL)	V	*1), ON
	Low		0	--	(0.4)	V	*1), OFF
Light Dimming Control (PWM) Input Voltage	High	V _{PDIM}	(2.5)	--	(5.5)	V	*1), ON
	Low		0	--	(0.4)	V	*1), OFF
PWM frequency	f _{PDIM}	(100)	(500)	(1000)	Hz	*3)	
Dimming Ratio (PWM Duty)	DR	(1)	--	100	%	*3)	
LED Life Time	LT	80,000	100,000	--	h	*4), *5)	

*1) Power and signals sequence: TBD

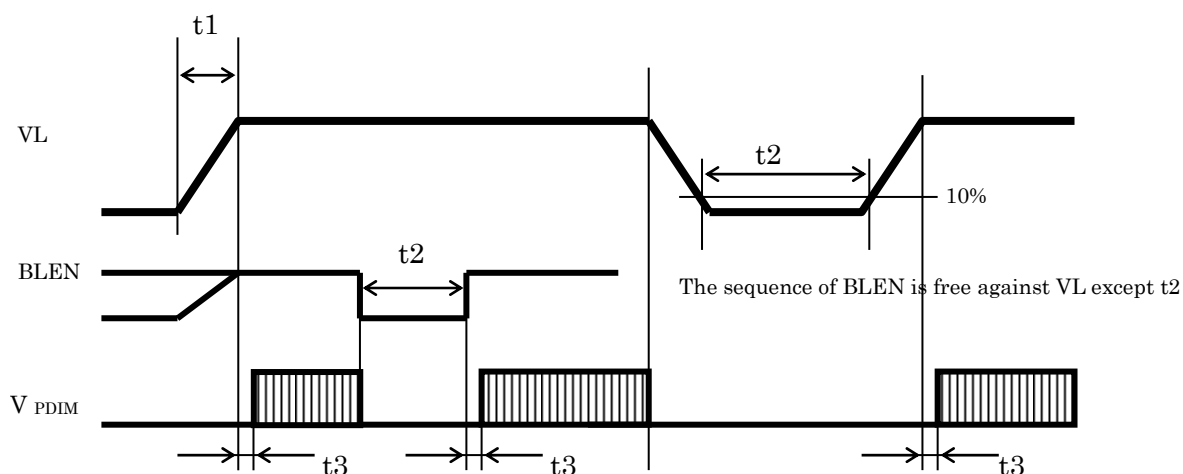

$$(0.1) \leq t1 \leq (100) \text{ [ms]}$$

$$(200) \leq t2 \text{ [ms]}$$

$$(0) \leq t3 \text{ [ms]}$$

*2) These data are for reference only. Power Supply Input Current (Rush Current) is influenced by power supply characteristics. (output impedance in particular) Therefore please evaluate LCD in advance.

*3) Lower frequency causes the flicker or the image breaking of motion picture.

Depending on the PDIM signal integrity (jitter etc.), the flicker may be visible. Please evaluate in advance.

*4) LED life time is defined as the time when the brightness becomes 50% of the initial value.

*5) By ambient environment, the LED lifetime changes particularly. Especially in case the product works in the atmosphere with Sulfur, Halide or of high temperature, the lifetime becomes short.

*6) Fuse

Parameter	Fuse Type Name	Supplier	Remark
VL	(FCC16162AB)	(Kamaya Electric Co., Ltd.)	*)

*) The power supply capacity should be designed to be more than the fusing current.

(3) Touch Panel

Electrical Characteristics

Ambient temperature: Ta = 25°C

ITEM	SYMBOL	MIN.	TYP.	MAX.	UNIT	Remarks	
Touch Panel Voltage	VDD5	4.5	5.0	5.5	V	*1)	
Touch Panel Current	ICCtp	--	50	200	mA		
Permissible Input Ripple Voltage	VRPtp	--	--	100	mVp-p	VDD5 = +5.0 V *2)	
Logic Input Voltage	High	VIHtp	0.8×VDD5	--	VDD5	V	SC, RESET *3)
	Low	VILtp	0	--	0.2×VDD5		
Position Accuracy	ΔEx ΔEy	-3.0	--	3.0	mm	Inner area*4)	
		-4.5	--	4.5	mm	Outer frame*4)	
Position Coordinate Output Rate (standard)	--	--	100	--	sps	Single touch *5)	

*1) Power and signals sequence:

- 0.1 ms ≤ t1 ≤ 10 ms 200 ms ≤ t4
- 0 < t2 ≤ 50 ms 2000 ms ≤ t5
- 0 < t3 ≤ 50 ms 0 ≤ t6

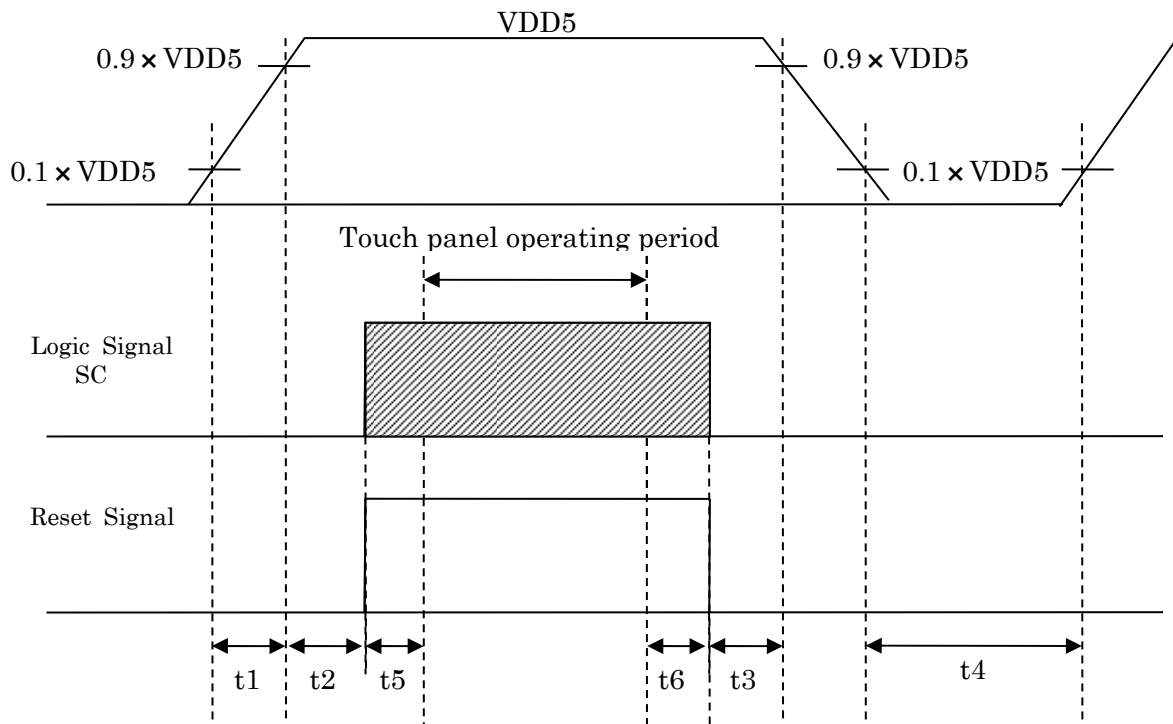

Initialization of touch panel controller (calibration of touch panel) is carried out during period between power supply turning on and start of touch panel operation, therefore please do not touch surface with finger, hold hands near touch surface, nor put conductive material like metal on touch panel.

If the calibration is not able to be carried out successfully at the initialization process, touch panel may not work properly for sometime.

*2) Ripple noise of touch panel power supply affects stability of touch detection and position accuracy. Therefore please use stabilized power supply to touch panel.

*3) Applied to SC(3pin), RESET(9pin).

For, please input signal of USB2.0 compliance to D- (10pin) & D+(11pin).

*4) Area of the finger touch is based on 10 mm in diameter.

Linearity is written as the difference of an actual touch position and the position coordinate which a touch controller outputs as an error (ΔE_x and ΔE_y stand for error length in the direction of X, Y, respectively).

The coordinates accuracy of peripheral part is valid when one-point touched.

* External noise may impact the coordinate accuracy significantly.

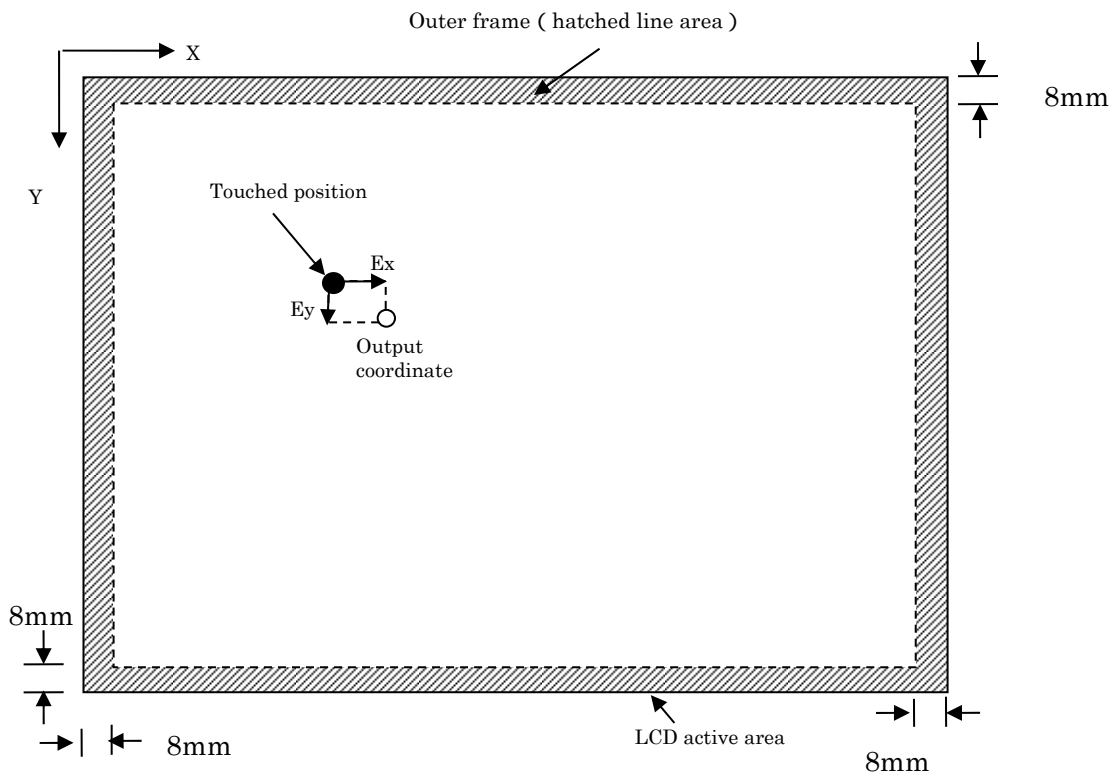

*5) The time interval of touch position coordinate output under an initial parameter condition

5. INTERFACE PIN CONNECTION

(1) CN 1(Interface Signal)

Used connector: 20186-020E-11F (I-PEX) or FI-SEB20P-HFE (JAE)

Corresponding connector: 20197-*20U-F (I-PEX) or FI-S20S[for discrete Wire],
FI-SE20ME [for FPC] (JAE)

Pin No.	Symbol	Function (ISP 6 bit compatibility mode)		Function (ISP 8 bit compatibility mode)
		6 bit input	8 bit input	
1	VCC	+3.3 V Power supply		←
2	VCC	+3.3 V Power supply		←
3	GND	GND		←
4	GND	GND		←
5	Link 0-	R0, R1, R2, R3, R4, R5, G0	R2, R3, R4, R5, R6, R7, G2	R0, R1, R2, R3, R4, R5, G0
6	Link 0+	R0, R1, R2, R3, R4, R5, G0	R2, R3, R4, R5, R6, R7, G2	R0, R1, R2, R3, R4, R5, G0
7	GND	GND		←
8	Link 1-	G1, G2, G3, G4, G5, B0, B1	G3, G4, G5, G6, G7, B2, B3	G1, G2, G3, G4, G5, B0, B1
9	Link 1+	G1, G2, G3, G4, G5, B0, B1	G3, G4, G5, G6, G7, B2, B3	G1, G2, G3, G4, G5, B0, B1
10	GND	GND		←
11	Link 2-	B2, B3, B4, B5, DENA	B4, B5, B6, B7, DENA	B2, B3, B4, B5, DENA
12	Link 2+	B2, B3, B4, B5, DENA	B4, B5, B6, B7, DENA	B2, B3, B4, B5, DENA
13	GND	GND		←
14	CLKIN-	Clock -		←
15	CLKIN+	Clock +		←
16	GND	GND		←
17	Link3-	See: *2)	R0, R1, G0, G1, B0, B1	R6, R7, G6, G7, B6, B7
18	Link3+	See: *2)	R0, R1, G0, G1, B0, B1	R6, R7, G6, G7, B6, B7
19	MODE	Low=ISP 6 bit compatibility mode		High=ISP 8 bit compatibility mode
20	SC	Scan direction control (Low=Normal, High=Reverse)		

*1) Metal frame is connected to signal GND.

*2) Recommended wiring of Pin 17,18 (6 bit input)

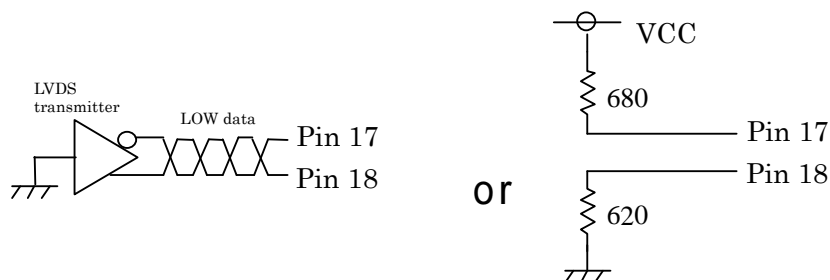

*3) Pin 19, 20 are pulled-down by 100 k Ω

(2) CN 2 (Backlight)

Backlight-side connector: 3800K-F06N-03L (ENTERY)

Corresponding connector: FI-S6S (JAE), H203K-D06N-12B (ENTERY)

Pin No.	Symbol	Function
1	VL	Power Supply Input Voltage
2	VL	Power Supply Input Voltage
3	GNDL	GND
4	GNDL	GND
5	BLEN	Backlight ON-OFF (High: ON, Low: OFF)
6	V _{PDIM}	Light Dimming Control (PWM) Input Voltage (High active)

*1) GNDL is connected GND (of CN1) and the LCD frame internally.

*2) BLEN is NOT designed for dimming.

(3) CN 3 (Touch Panel Interface)

Used connector: SM12B-SHLS-TF(LF)(SN) (JST)

Corresponding connector: SHLP-12V-S-B (JST)

Pin No.	Symbol	Function	Connection to host equipment *3)
1	TEST1	(Internal use) *1)	NC
2	TEST2	(Internal use) *1)	NC
3	SC	Reverse of coordinate *2)	SC
4	GND	Touch panel controller GND	GND
5	TEST3	(Internal use) *1)	NC
6	TEST4	(Internal use) *1)	NC
7	TEST5	(Internal use) *1)	NC
8	TEST6	(Internal use) *1)	NC
9	RESET	Touch panel reset (H: Usually, L: Reset)	RESET
10	D-	USB D-Terminal	D-
11	D+	USB D+Terminal	D+
12	VDD5 (VBUS)	Touch panel power supply(5V)	Power supply 5V

*1) Please don't use TEST1 (1pin), TEST2 (2pin), TEST3 (5pin), TEST4 (6pin), TEST5 (7pin) and TEST6 (8pin) because they are for internal use only.

*2) SC is signal to change zero point of touch panel position coordinate.

If it is not connected, Position Coordinate is Default condition.

Signal (H:5V,L:0V)	Position Coordinate (Zero point)	Note
L		Default condition *2)
H		

*3) NC should be open.

Specification of communication between the controller and host.

- Please follow USB 2.0 standard.

(4) ISP data mapping

a. ISP 6 bit compatibility mode(6 bit input)

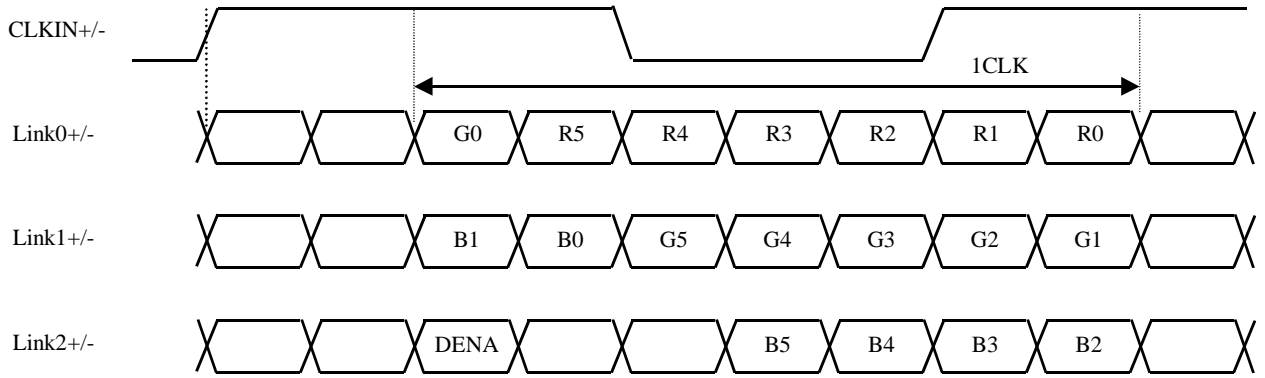

b. ISP 6 bit compatibility mode(8 bit input)

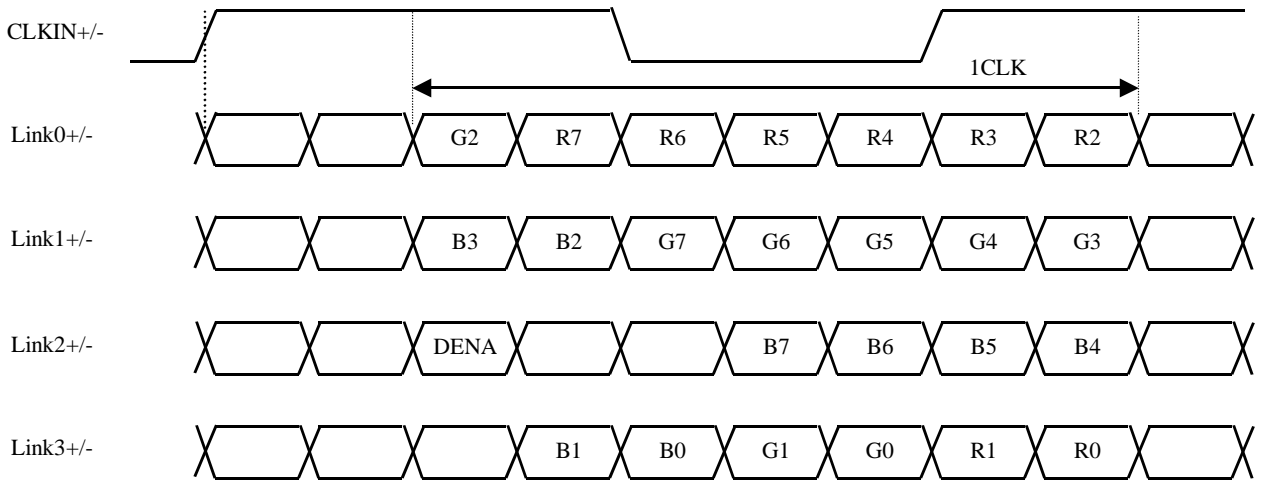

c. ISP 8 bit compatibility mode

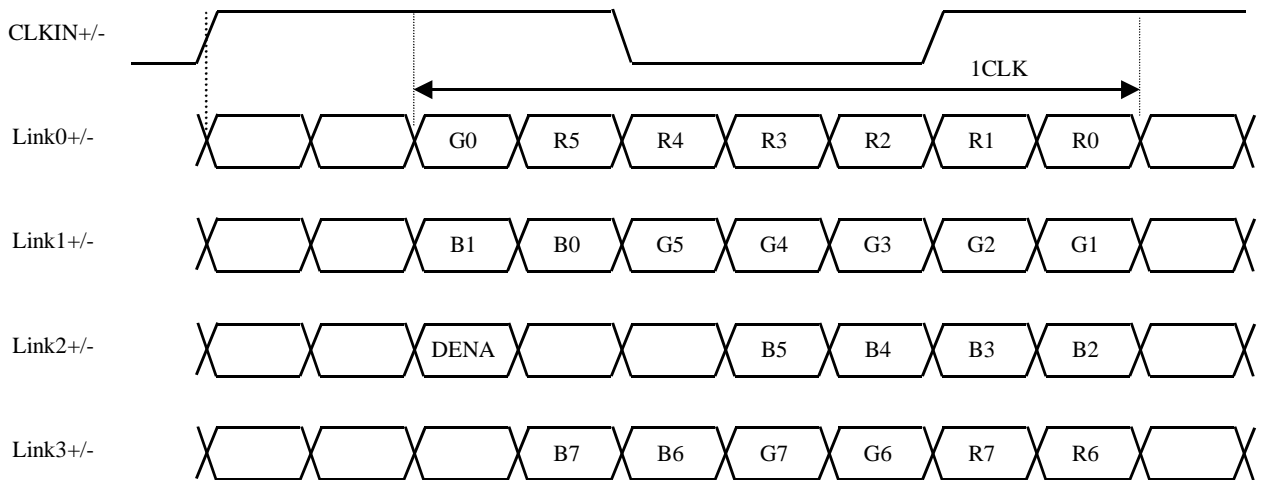

6. INTERFACE TIMING

LVDS transmitter input signal

(1) Timing Specifications

ITEM		SYMBOL	MIN	TYP	MAX	UNIT	
DCLK	Frequency	f _{CLK}	50	62.8	75	MHz	
	Period	t _{CLK}	13.3	15.9	20	ns	
DENA	Horizontal	Active Time	t _{HA}	1280	1280	1280	t _{CLK}
		Blanking Time	t _{HB}	30	32	256	t _{CLK}
		Frequency	f _H	42.4	47.9	60	kHz
		Period	t _H	16.7	20.9	23.6	μs
	Vertical	Active Time	t _{VA}	768	768	768	t _H
		Blanking Time	t _{VB}	13	30	--	t _H
		Frequency	f _V	55	60	65	Hz
		Period	t _V	15.4	16.7	18.2	ms

[Note]

- 1) DENA (Data Enable) should always be positive polarity as shown in the timing specification.
- 2) DCLK should appear during all invalid period.
- 3) In case of blanking time fluctuation, please satisfy following condition.: TBD

$$T_{HBn-1} - 2(t_{CLK}) < T_{HBn} < T_{HBn-1} + 2(t_{CLK}) \text{ (For active area only)}$$

4) LVDS Timing Specifications: TBD

ITEM	SYMBOL	MIN	TYP	MAX	UNIT
1 bit Period	UI	--	1/7	--	t _{CLK}
Position 1	T _{POS1}	(-0.15)	0	(0.15)	UI
Position 2	T _{POS2}	(0.65)	--	(1.15)	UI
Position 3	T _{POS3}	(0.65)	1	(1.15)	UI
Position 4	T _{POS4}	(1.65)	--	(2.15)	UI
Position 5	T _{POS5}	(1.65)	2	(2.15)	UI
Position 6	T _{POS6}	(2.65)	--	(3.15)	UI
Position 7	T _{POS7}	(2.65)	3	(3.15)	UI
Position 8	T _{POS8}	(3.65)	--	(4.15)	UI
Position 9	T _{POS9}	(3.65)	4	(4.15)	UI
Position 10	T _{POS10}	(4.65)	--	(5.15)	UI
Position 11	T _{POS11}	(4.65)	5	(5.15)	UI
Position 12	T _{POS12}	(5.65)	--	(6.15)	UI
Position 13	T _{POS13}	(5.65)	6	(6.15)	UI
Position 14	T _{POS14}	(6.65)	--	(7.15)	UI

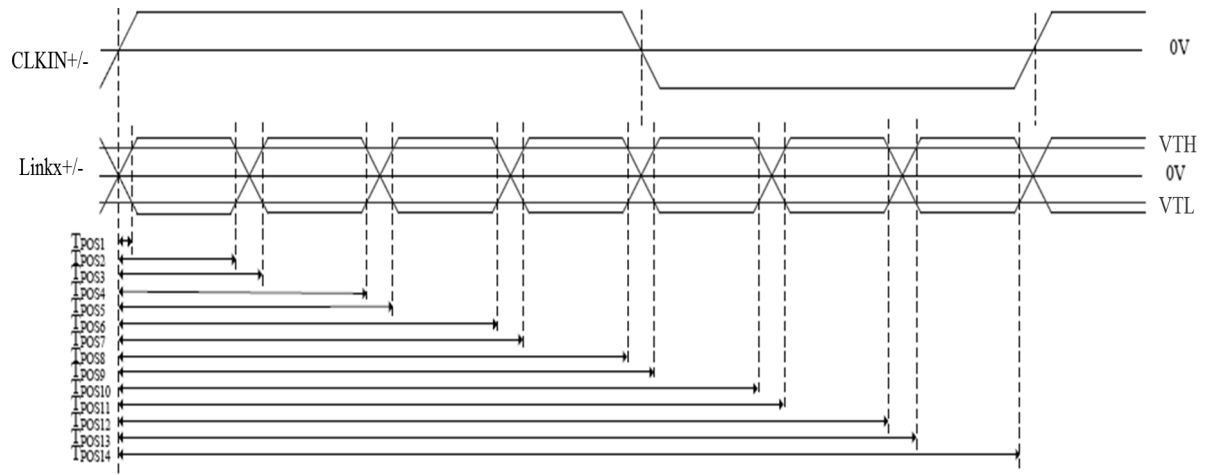

(2) Timing Chart

a. Horizontal Timing Chart

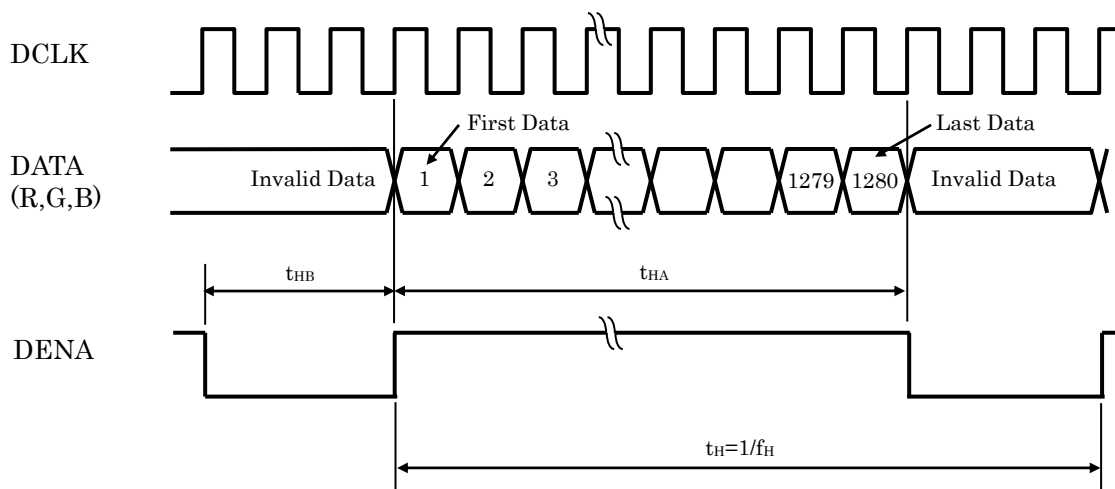

b. Vertical Timing Chart

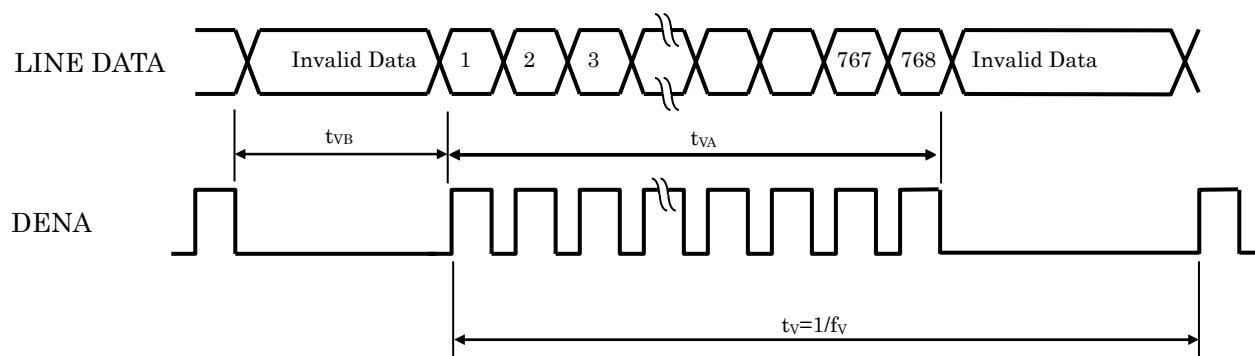

(3) Color Data Assignment

a. 6 bit input

COLOR		INPUT DATA																	
		R DATA						G DATA						B DATA					
		R5	R4	R3	R2	R1	R0	G5	G4	G3	G2	G1	G0	B5	B4	B3	B2	B1	B0
		MSB			LSB			MSB			LSB			MSB		LSB			
BASIC COLOR	BLACK	0	0	0	0	0	0	0	0	0	0	0	0	0	0	0	0	0	0
	RED(63)	1	1	1	1	1	1	0	0	0	0	0	0	0	0	0	0	0	0
	GREEN(63)	0	0	0	0	0	0	1	1	1	1	1	1	0	0	0	0	0	0
	BLUE(63)	0	0	0	0	0	0	0	0	0	0	0	0	1	1	1	1	1	1
	CYAN	0	0	0	0	0	0	1	1	1	1	1	1	1	1	1	1	1	1
	MAGENTA	1	1	1	1	1	1	0	0	0	0	0	0	1	1	1	1	1	1
	YELLOW	1	1	1	1	1	1	1	1	1	1	1	1	0	0	0	0	0	0
	WHITE	1	1	1	1	1	1	1	1	1	1	1	1	1	1	1	1	1	1
RED	RED(1)	0	0	0	0	0	1	0	0	0	0	0	0	0	0	0	0	0	0
	RED(2)	0	0	0	0	1	0	0	0	0	0	0	0	0	0	0	0	0	0
	RED(62)	1	1	1	1	1	0	0	0	0	0	0	0	0	0	0	0	0	0
	RED(63)	1	1	1	1	1	1	0	0	0	0	0	0	0	0	0	0	0	0
GREEN	GREEN(1)	0	0	0	0	0	0	0	0	0	0	0	1	0	0	0	0	0	0
	GREEN(2)	0	0	0	0	0	0	0	0	0	0	1	0	0	0	0	0	0	0
	GREEN(62)	0	0	0	0	0	0	1	1	1	1	1	0	0	0	0	0	0	0
	GREEN(63)	0	0	0	0	0	0	1	1	1	1	1	1	0	0	0	0	0	0
BLUE	BLUE(1)	0	0	0	0	0	0	0	0	0	0	0	0	0	0	0	0	0	1
	BLUE(2)	0	0	0	0	0	0	0	0	0	0	0	0	0	0	0	0	1	0
	BLUE(62)	0	0	0	0	0	0	0	0	0	0	0	0	1	1	1	1	1	0
	BLUE(63)	0	0	0	0	0	0	0	0	0	0	0	0	1	1	1	1	1	1

[Note]

- 1) Definition of gray scale
Color (n) --- n indicates gray scale level.
Higher n means brighter level.

- 2) Data
1: High, 0: Low

b. 8 bit input

COLOR		INPUT DATA																							
		R DATA								G DATA								B DATA							
		R7	R6	R5	R4	R3	R2	R1	R0	G7	G6	G5	G4	G3	G2	G1	G0	B7	B6	B5	B4	B3	B2	B1	B0
		MSB				LSB				MSB				LSB				MSB				LSB			
BASIC COLOR	BLACK	0	0	0	0	0	0	0	0	0	0	0	0	0	0	0	0	0	0	0	0	0	0	0	0
	RED(255)	1	1	1	1	1	1	1	1	0	0	0	0	0	0	0	0	0	0	0	0	0	0	0	0
	GREEN(255)	0	0	0	0	0	0	0	0	1	1	1	1	1	1	1	1	0	0	0	0	0	0	0	0
	BLUE(255)	0	0	0	0	0	0	0	0	0	0	0	0	0	0	0	0	1	1	1	1	1	1	1	1
	CYAN	0	0	0	0	0	0	0	0	1	1	1	1	1	1	1	1	1	1	1	1	1	1	1	1
	MAGENTA	1	1	1	1	1	1	1	1	0	0	0	0	0	0	0	0	1	1	1	1	1	1	1	1
	YELLOW	1	1	1	1	1	1	1	1	1	1	1	1	1	1	1	1	0	0	0	0	0	0	0	0
	WHITE	1	1	1	1	1	1	1	1	1	1	1	1	1	1	1	1	1	1	1	1	1	1	1	1
RED	RED(1)	0	0	0	0	0	0	0	1	0	0	0	0	0	0	0	0	0	0	0	0	0	0	0	0
	RED(2)	0	0	0	0	0	0	1	0	0	0	0	0	0	0	0	0	0	0	0	0	0	0	0	0
	RED(255)	1	1	1	1	1	1	1	1	0	0	0	0	0	0	0	0	0	0	0	0	0	0	0	0
GREEN	GREEN(1)	0	0	0	0	0	0	0	0	0	0	0	0	0	0	0	1	0	0	0	0	0	0	0	0
	GREEN(2)	0	0	0	0	0	0	0	0	0	0	0	0	0	0	1	0	0	0	0	0	0	0	0	0
	GREEN(255)	0	0	0	0	0	0	0	0	1	1	1	1	1	1	1	1	0	0	0	0	0	0	0	0
BLUE	BLUE(1)	0	0	0	0	0	0	0	0	0	0	0	0	0	0	0	0	0	0	0	0	0	0	0	1
	BLUE(2)	0	0	0	0	0	0	0	0	0	0	0	0	0	0	0	0	0	0	0	0	0	0	1	0
	BLUE(255)	0	0	0	0	0	0	0	0	0	0	0	0	0	0	0	0	1	1	1	1	1	1	1	1

[Note]

1) Definition of gray scale

Color (n) --- n indicates gray scale level.
Higher n means brighter level.

2) Data

1: High, 0: Low

(4) Display Position and Scan Direction

D(X,Y) shows the data number of input signal.

SC: Low

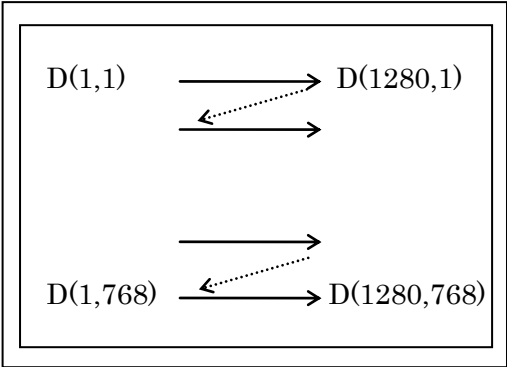

SC: High

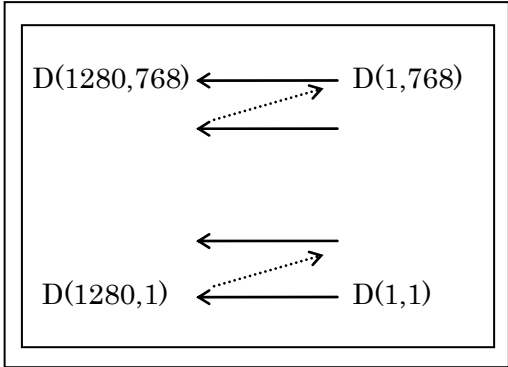

7. BLOCK DIAGRAM

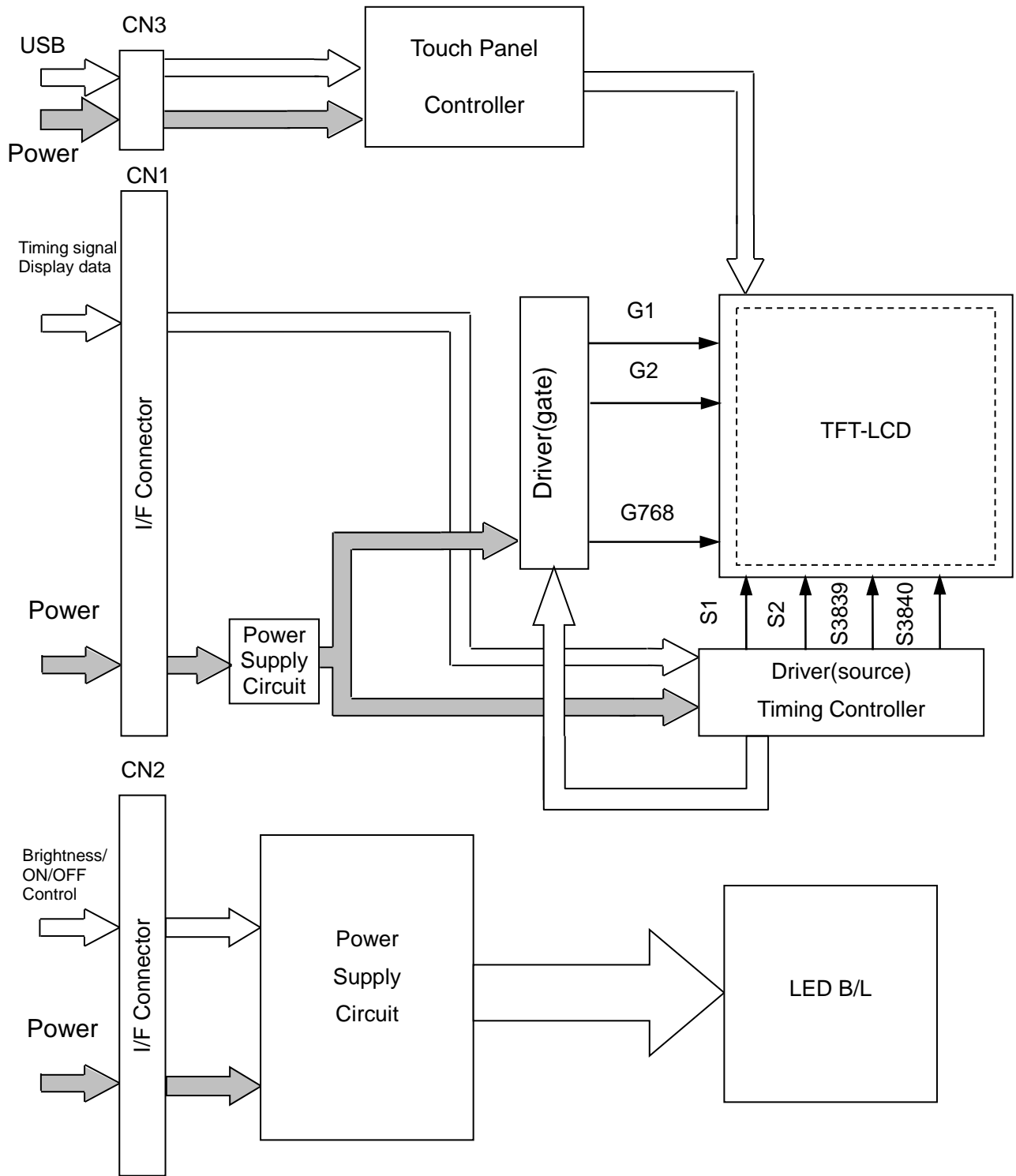

(3) Touch Panel Design Guide

1) Operating Precautions

- Please operate touch panel by finger. It does not sense by tip of nail.
- Sensing is affected by how strongly touched (touched finger area), glove thickness (distance) and material.

2) Assembly Precautions

- Please connect touch panel controller GND to stable earth ground with little noise.
When there is no connection to the earth ground, please make bypass between touch panel controller GND and the earth ground to prevent noise.
- Please use non-conductive material for customer side housing around touch panel.
When conductive material is used for the housing, please make space more than 2mm from touch panel surface, and also please design the housing strong enough not to change its distance. Please design the housing to prevent electrical noise. (Ex. to connect to GND)
- Please keep space between FPC and noise source like metal parts and signal cables. Please keep space more than 2mm from FPC and also design not to change its distance.
- Please do not make an impact on the cover glass edge.

9. OPTICAL CHARACTERISTICS

Ta=25°C, VCC=3.3V, VL = 12.0V, Input Signals: Typ. values shown in Section 6

ITEM		SYMBOL	CONDITION	MIN	TYP	MAX	UNIT	Remarks
Contrast Ratio		CR	$\theta_V=0^\circ, \theta_H=0^\circ$	650	1000	--	--	*1)*2)*5)
Luminance		Lw	$\theta_V=0^\circ, \theta_H=0^\circ$	(640)	(800)	--	cd/m ²	*1)*5)
Luminance Uniformity		ΔLw	$\theta_V=0^\circ, \theta_H=0^\circ$	--	--	30	%	*1)*3)*5)
Response Time		tr	$\theta_V=0^\circ, \theta_H=0^\circ$	--	12	--	ms	*1)*4)*5)
		tf	$\theta_V=0^\circ, \theta_H=0^\circ$	--	12	--	ms	*1)*4)*5)
Viewing Angle	Horizontal	θ_H	CR \geq 10	-70~70	(-88~88)	--	°	*1)*5)
	Vertical	θ_V		-70~70	(-88~88)	--	°	*1)*5)
Image sticking		tis	2 h	--	--	2	s	*6)
Color Coordinates	Red	Rx	$\theta_V=0^\circ, \theta_H=0^\circ$	(0.533)	(0.573)	(0.613)	--	*1)*5)
		Ry		(0.273)	(0.313)	(0.353)		
	Green	Gx		(0.297)	(0.337)	(0.377)		
		Gy		(0.534)	(0.574)	(0.614)		
	Blue	Bx		(0.116)	(0.156)	(0.196)		
		By		(0.078)	(0.118)	(0.158)		
	White	Wx		(0.273)	(0.313)	(0.353)		
		Wy		(0.289)	(0.329)	(0.369)		

[Note]

These items are measured using EZContrast XL88F(ELDIM) for viewing angle, RD-80SA(TOPCON) for response time and CS-2000 (KONICA MINOLTA) or equivalent equipment for others under the dark room condition (no ambient light) after more than 30 minutes from turning on the backlight unless noted.

Condition: $V_{PDIM} = (2.5 \sim 5.5) \text{ VDC}$ (DUTY = 100%)

Measurement method for luminance and color coordinates is as follows.

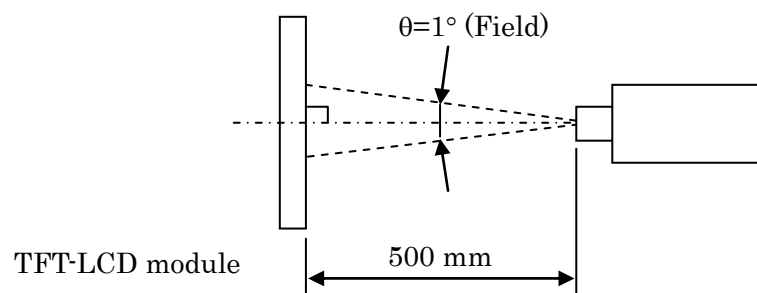

The luminance is measured according to FLAT PANEL DISPLAY MEASUREMENTS STANDARD (VESA Standard).

*1) Measurement Point

Contrast Ratio, Luminance, Response Time, Viewing Angle, Color Coordinates: Display Center
 Luminance Uniformity: point 1~5 shown in a figure below

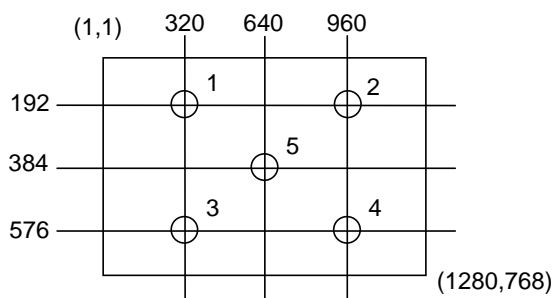

*2) Definition of Contrast Ratio

$$CR = \text{Luminance with all white pixels} / \text{Luminance with all black pixels}$$

*3) Definition of Luminance Uniformity

$$\Delta L_w = [L_w(\text{MAX}) / L_w(\text{MIN}) - 1] \times 100$$

*4) Definition of Response Time

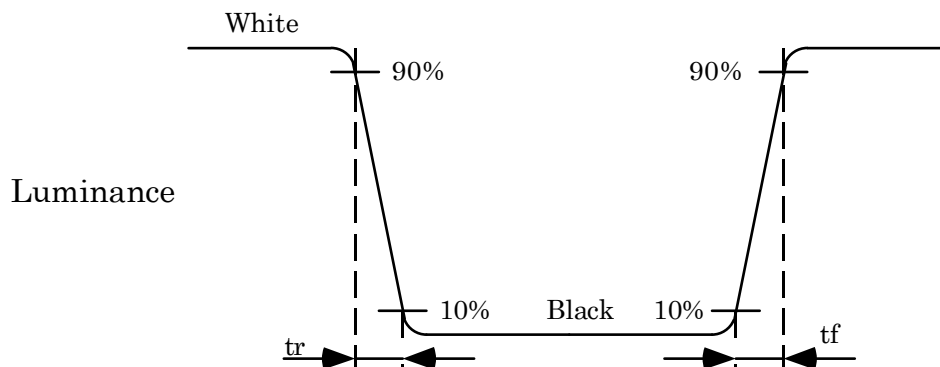

*5) Definition of Viewing Angle (θ_v , θ_H)

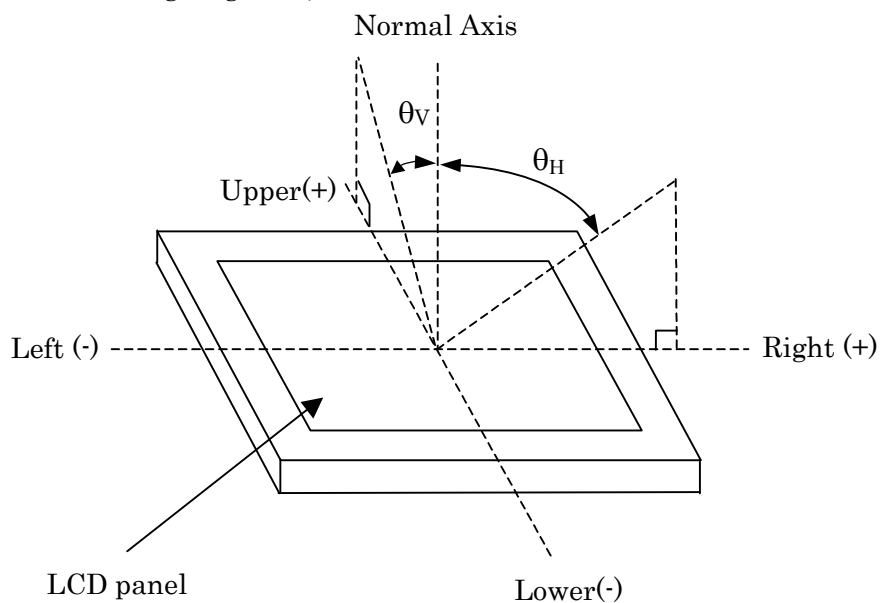

*6) Image sticking:

Continuously display the test pattern shown in the figure below for two-hours. Then display a completely white screen. The previous image shall not persist more than two seconds at 25°C.

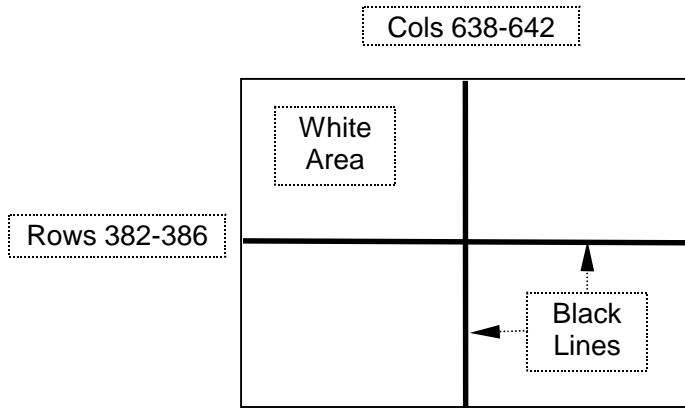

TEST PATTERN FOR IMAGE STICKING TEST

10. RELIABILITY TEST CONDITION

(1) Temperature and Humidity

ITEM	CONDITIONS
HIGH TEMPERATURE HIGH HUMIDITY OPERATION	40°C, 90%RH, 240 h (No condensation)
HIGH TEMPERATURE OPERATION	(70°C), 240 h
LOW TEMPERATURE OPERATION	(-30°C), 240 h
HIGH TEMPERATURE STORAGE	(80°C), 240 h
LOW TEMPERATURE STORAGE	(-30°C), 240 h
THERMAL SHOCK (NON-OPERATION)	(-30°C) (1h) ~ (80°C) (1h), 100 cycles

(2) Shock & Vibration

ITEM	CONDITIONS
SHOCK (NON-OPERATION)	Shock level: 980 m/s ² (100G) Waveform: half sinusoidal wave, 2 ms Number of shocks: one shock input in each direction of three mutually perpendicular axes for a total of six shock inputs
VIBRATION (NON-OPERATION)	Vibration level: 9.8 m/s ² (1.0G) Waveform: sinusoidal Frequency range: 5 to 500 Hz Frequency sweep rate: 0.5 octave /min Duration: one sweep from 5 to 500 Hz in each of three mutually perpendicular axis(each x,y,z axis: 1 hour, total 3 hours)

(3) ESD Test

ITEM	CONDITIONS
CONTACT DISCHARGE (OPERATION)	150pF, 330Ω, ±8kV, 10 times at 1 sec interval
SIGNAL PIN DISCHARGE (NON-OPERATION)	200pF, 0Ω, ±200V, 10 times at 1 sec interval

(4) Judgment standard

The judgment of the above tests should be made as follow:

a. TFT-LCD

Pass: Normal display image, no damage of the display function. (ex. no line defect)

Partial transformation of the module parts should be ignored.

Fail: No display image, damage of the display function. (ex. line defect)

b. Touch Panel

Pass: No damage of the touch function. (ex. touch detection cannot be performed.)

Fail: Touch panel is damaged. (ex. Touch panel does not work, or touch detection cannot be performed.)

11. OTHER FEATURE

(1) Environmental Restriction /Law Compliance

This LCD module complies with RoHS*) directive.

*) RoHS: Restriction of the use of certain hazardous substances in electrical and electronic equipment

(2) Safety Standard Authorization

UL1950 Recognized (UL File# E158720)

12. HANDLING PRECAUTIONS FOR TFT-LCD MODULE

Please pay attention to the followings in handling TFT-LCD products:

(1) ASSEMBLY PRECAUTION

- a. Please mount the LCD module by using mounting hole with a screw clamping torque less than 0.2 Nm. Please do not bend or wrench the LCD module in assembling. Please do not drop, bend or twist the LCD module in handling.
- b. Please design display housing in accordance with the following guide lines.
 - (a) Housing case must be designed carefully so as not to put stress on LCD and not to wrench module. If customer uses compression mounting, please evaluate housing case with LCD carefully to avoid image quality issue caused by mechanical stress.
 - (b) Under high temperature environment, performance and life time of LED may heavily shorten. When you design with our LCD product, please consider radiating heat and ventilation for good heat management.
 - (c) Keep sufficient clearance between LCD module back surface and housing when the LCD module is mounted. Approximately 1.0mm of the clearance in the design is recommended taking into account the tolerance of LCD module thickness and mounting structure height on the housing.
 - (d) When some parts, such as, FPC cable and ferrite plate, are installed underneath the LCD module, still sufficient clearance is required, such as 0.5mm. This clearance is, especially, to be reconsidered when the additional parts are implemented for EMI countermeasure.
 - (e) Keep sufficient clearance between LCD module and the others parts, such as inverter and speaker so as not to interfere the LCD module. Approximately 1.0 mm of the clearance in the design is recommended.
 - (f) To avoid local elevation/decrease of temperature, considering location of heating element, heat release, thermal design should be done.
 - (g) Please use appropriate measures to avoid water going into LCD module. Especially, in case of LCD module using part with printing, water contacts printed material might cause printing degradation, for example, peeling off or discoloration.
- c. Please do not push or scratch touch panel surface with anything hard.
- d. Do not use or store the product under a condition where the product will be exposed to water, organic solution or acid.
- e. Please wipe off touch panel surface with absorbent cotton or soft cloth in case of it being soiled.
- f. Do not make an impact on the edge of the cover glass.
- g. Please do not take a LCD module to pieces and reconstruct it. Resolving and reconstructing modules may cause them not to work well.
- h. Please do not touch metal frames with bare hands and soiled gloves. A color change of the metal frames can happen during a long preservation of soiled LCD modules.
- i. Please handle metal frame carefully because edge of metal frame is very sharp.

- j. Please connect the metal frame of LCD module to GND in order to minimize the effect of external noise and EMI.
- k. Be sure to connect the cables and the connectors correctly.

(2) OPERATING PRECAUTIONS

- a. Please be sure to turn off the power supply before connecting and disconnecting signal input cable.
- b. Please do not change variable resistance settings in LCD module. They are adjusted to the most suitable value. If they are changed, it might happen LCD does not satisfy the characteristics specification.
- c. The interface signal speed is very high. Please pay attention to transmission line design and other high speed signal precautions to satisfy signal specification.
- d. Condensation might happen on the surface and inside of LCD module in case of sudden change of ambient temperature.
- e. Please pay attention not to display the same pattern for very long time. Image sticking might happen on LCD. Although image sticking may disappear as the operation time proceeds, screen saver function is recommended not to cause image sticking.
- f. Please obey the same safe instructions as ones being prepared for ordinary electronic products.

(3) PRECAUTIONS WITH ELECTROSTATICS

- a. This LCD module use CMOS-IC on circuit board and TFT-LCD panel, and so it is easy to be affected by electrostatics. Please be careful with electrostatics by the way of your body connecting to the ground and so on.
- b. Please remove protection film very slowly from the surface of touch panel to prevent from electrostatics occurrence.

(4) STORAGE PRECAUTIONS

LCD should be stored in the room temperature environment with normal humidity. The LCD inventory should be processed by first-in first-out method.

(5) SAFETY PRECAUTIONS

- a. When you waste damaged or unnecessary LCDs, it is recommended to crush LCDs into pieces and wash them off with solvents such as acetone and ethanol, which should later be burned.
- b. If any liquid leaks out of a damaged glass cell and comes in contact with the hands, wash off thoroughly with soap and water.

(6) OTHERS

- a. A strong incident light into LCD panel may cause deterioration to touch panel, polarizer film, color filter, and other materials, which will degrade the quality and performance of display.
Please do not expose LCD module under strong Ultraviolet rays for a long time. If using under direct sunlight condition, please test the reliability and performance completely.
- b. For the packaging box handling, please see and obey with the packaging specification datasheet.