

Notes :

- * Insulation: Nylon 6T UL 94V-0, Color Nature
- * Contact : Phosphor Bronze
- * Fixed Tab : Brass with Matte Tin Plated
- * Recommended mating part:
Housing: CI44**S0000-L
Terminal: CI44T011PP0
- * For Lead-Free IR Reflow process

ORDERING CODE:

CI44 ** M * H ** -NH
 ① ② ③ ④ ⑤ ⑥ ⑦

- ① Series No.:
- ② No. of circuits: 02 TO 15
- ③ Contacts type: M= SMT
- ④ Plating option:
1= Matte Tin Plated over Nickel
2= Gold flash plated over Nickel
- ⑤ Tail style: H= Right angle
- ⑥ Option: 00= Standard(Tube packing)
R0= Tape & Reel packing
- ⑦ Other option:
-NH=For Lead Free IR Processes and Halogen-Free

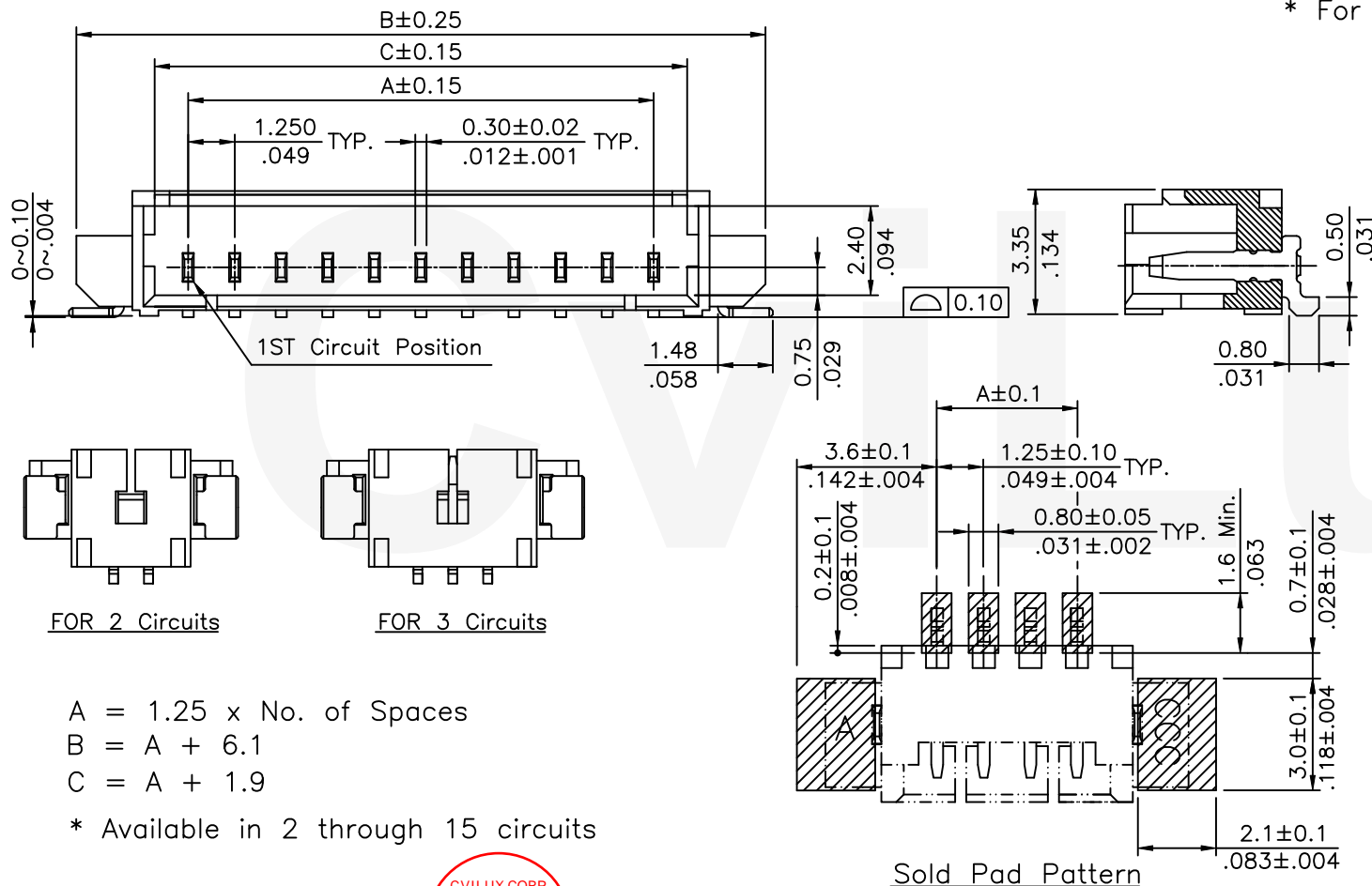

A = 1.25 x No. of Spaces
 B = A + 6.1
 C = A + 1.9

* Available in 2 through 15 circuits

Halogen-Free

Lead Free Process

RoHS compliant

CVILUX CORP
2019.08.22
ISSUED

5	Sun	8/15-19'	ECNT119210	DATE	UNIT: mm / inch	TITLE: 1.25MM(.049") RIGHT ANGLE SMT TYPE HEADER	 瀚荃股份有限公司 CviLux Corporation
4	Karen	12/09-14'	ECNT114252/ECRT114090	DRAWN BY: Sun	8/15-19'	TOLERANCE UNLESS OTHERWISE SPECIFIED	
3	Ellie	9/24-14'	ECNT114210	ENGINEER: Sun	8/15-19'	.X ± 0.25/.010 X' ± 1'	
2	Enya	7/26-12'	ECN12176-0 / ECR12061-1	CHECKED BY: Eisley	8/16-19'	.XX ± 0.15/.006 X" ±	
SYM	NAME	DATE	REVISIONS	APPROVED BY: Eisley	8/16-19'	.XXX ± 0.08/.003 XX" ±	
DRAWING NO. CI4447SF							PART NO. CI44**M*H**-NH
SCALE 5 / 1							SHEET 1 OF 2

NOTE :

- △ * Reel Material : Corrugated Paper
- * Carrier Material : Clear, Conductive Polystyrene Alloy
- * Cover Tape Material : Polyester
- * Cover Tape Peel Strength : 0.1N – 1.3N
- * Carrier camber is within 1mm in 100mm
- * All dimensions meet EIA-481-2 & EIA-481-3 requirements.
- * Quantity : 1400 PCS/Reel

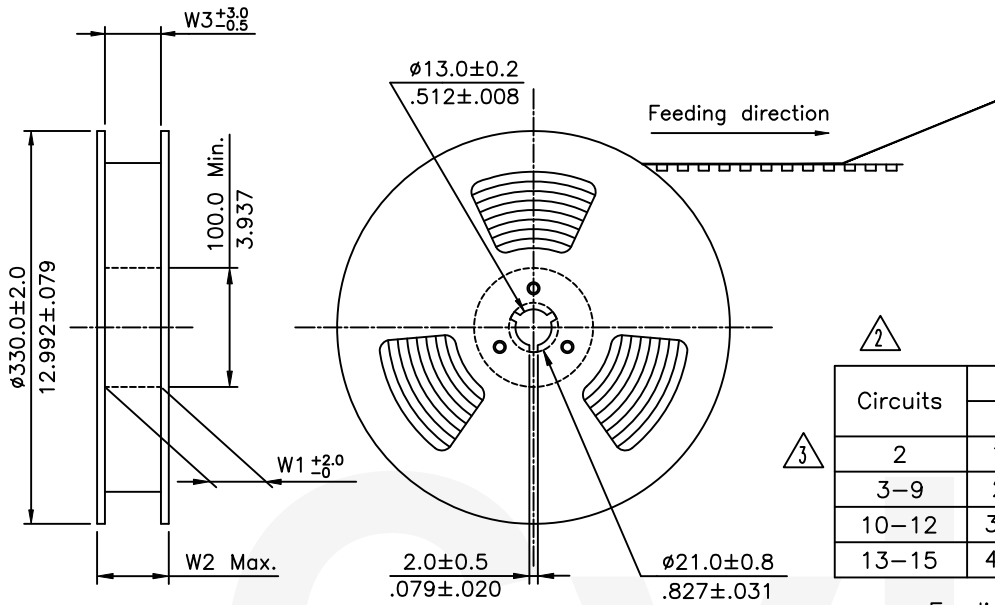

Circuits	Dimension					Packing (Reel/Carton)
	E	F	W1	W2	W3	
2	16.0(.630)	---	16.5(.650)	22.5(.886)	16.5(.650)	11
3-9	24.0(.945)	---	24.5(.965)	30.5(1.201)	24.5(.965)	9
10-12	32.0(1.260)	28.40(1.118)	32.5(1.280)	38.5(1.516)	32.5(1.280)	7
13-15	44.0(1.732)	40.40(1.591)	44.5(1.752)	50.5(1.988)	44.5(1.752)	5

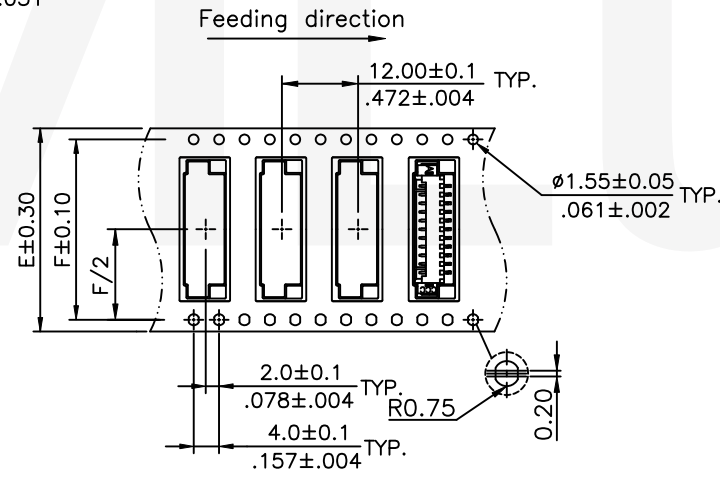
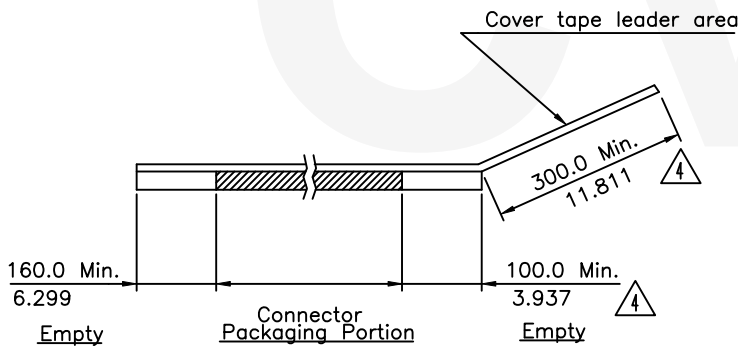

WIDTH : 32,44 mm Carrier

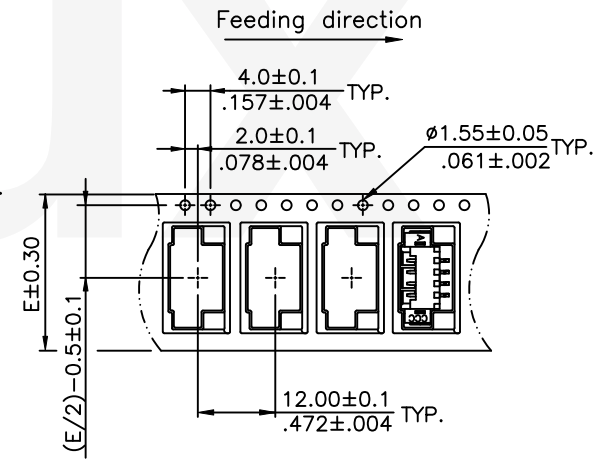

WIDTH : 16,24 mm Carrier

RoHS Compliant

CVILUX CORP
 2019.08.22
 ISSUED

△5	Sun	8/15-19'	ECNT119210	DATE	UNIT: mm / inch	TITLE: 1.25MM(.049")	瀚荃股份有限公司 CviLux Corporation
△4	Karen	12/09-14'	ECNT114252/ECRT114090	DRAWN BY: Sun	8/15-19'	RIGHT ANGLE SMT TYPE HEADER	
△3	Ellie	9/24-14'	ECNT114210	ENGINEER: Sun	8/15-19'	MATERIAL:	DRAWING NO. CI4447SF PART NO. CI44**M*H**-NH SCALE SHEET 2 OF 2
△2	Enya	7/26-12'	ECN12176-0 / ECR12061-1	CHECKED BY: Eisley	8/16-19'	FINISH:	
SYM	NAME	DATE	REVISIONS	APPROVED BY: Eisley	8/16-19'		