

FEATURES

1. Wide input voltage range (2:1)
2. High efficiency up to 86%
3. I/O isolation test voltage 1.5k VDC
4. Output short-circuit protection(self-recovery)
5. Operating ambient temperature range: -40°C to +85°C
6. Meet CISPR32/EN55032 CLASS A, without extra components
7. Meet EN62368 standards



3 years
Warranty

Selection Guide

Part No.	Input Voltage (VDC)		Output		Full Load Efficiency% (Min./Typ.)	Capacitive Load Max. (µF)
	Nominal (Range)	Maximum	Voltage (VDC)	Current Max.(mA)		
NKA0505ZP-3WR2	5 (4.5-9)	11	±5	±300/±15	74/76	2200
NKA0509ZP-3WR2			±9	±166/±8	74/76	1800
NKA0512ZP-3WR2			±12	±125/±6	76/78	1800
NKA0515ZP-3WR2			±15	±100/±5	76/78	1000
NKB0505ZP-3WR2			5	600/30	72/74	4700
NKB0512ZP-3WR2			12	250/12	75/77	2700
NKB0515ZP-3WR2			15	200/10	75/77	2200
NKA1205ZP-3WR2	12 (9-18)	20	±5	±300/±15	79/81	2200
NKA1209ZP-3WR2			±9	±166/±8	82/84	2000
NKA1212ZP-3WR2			±12	±125/±6	82/84	1800
NKA1215ZP-3WR2			±15	±100/±5	83/85	1000
NKB1203ZP-3WR2			3.3	909/46	72/74	4700
NKB1205ZP-3WR2			5	600/30	79/81	4700
NKB1212ZP-3WR2			12	250/12	81/83	2700
NKB1215ZP-3WR2			15	200/10	80/82	2200
NKB1224ZP-3WR2			24	2025/6	81/83	1800
NKA2405ZP-3WR2	24 (18-36)	40	±5	±300/±15	80/82	2200
NKA2412ZP-3WR2			±12	±125/±6	82/84	1800
NKA2415ZP-3WR2			±15	±100/±5	82/84	1000
NKB2403ZP-3WR2			3.3	909/46	76/78	4700
NKB2405ZP-3WR2			5	600/30	79/81	4700
NKB2409ZP-3WR2			9	333/16	79/81	2700
NKB2412ZP-3WR2			12	250/12	84/86	2700
NKB2415ZP-3WR2			15	200/10	84/86	2200
NKB2424ZP-3WR2			24	2025/6	83/85	1800
NKA4805ZP-3WR2	48 (36-75)	80	±5	±300/±15	80/82	2200
NKA4812ZP-3WR2			±12	±125/±6	82/84	1800
NKA4815ZP-3WR2			±15	±100/±5	83/85	1000
NKA4824ZP-3WR2			±24	±63/±3	82/84	680

NKB4803ZP-3WR2			3.3	909/46	74/76	4700
NKB4805ZP-3WR2	48 (36-75)	80	5	600/30	80/82	4700
NKB4812ZP-3WR2			12	250/12	84/86	2700
NKB4815ZP-3WR2			15	200/10	84/86	2200
NKB4824ZP-3WR2			24	2025/6	82/84	1000

Input Specifications

Item	Operating Conditions	Min.	Typ.	Max.	Unit
Input Current (full load/no load)	5VDC Input	--	789/40	834/45	mA
	12VDC Input	--	316/30	347/35	
	24VDC Input	--	152/15	165/20	
	48VDC Input	--	77/5	85/10	
Reflected Ripple Current	5VDC Input	--	20	--	
	12VDC Input	--	30	--	
	24VDC Input	--	30	--	
	48VDC Input	--	30	--	
Impulse Voltage	5VDC Input	-0.7	--	12	VDC
	12VDC Input	-0.7	--	25	
	24VDC Input	-0.7	--	50	
	48VDC Input	-0.7	--	100	
Starting Voltage	5VDC Input	--	--	4.5	
	12VDC Input	--	--	9	
	24VDC Input	--	--	18	
	48VDC Input	--	--	36	
Input Filter		PI filter			
Hot Plug		Unavailable			

Output Specifications

Item	Operating Conditions	Min.	Typ.	Max.	Unit	
Output Voltage Accuracy	5% - 100% Load	--	±1	±3.0	%	
Linear Regulation	Full load, Input voltage from low limit to high limit	Vo1	±0.2	±0.5		
		V02				
Load Regulation	5% - 100% Load	Vo1	±0.2	±0.5		
		V02				
Ripple & Noise	20MHZ Bandwidth	24VDC Input	--	100	120	mVp-p

		Other	--	50	80	
Transient Recovery Time	25% load step change		--	0.5	2	ms
Transient Response Deviation			--	±2	±5	%
Temperature Coefficient	Full Load		--	±0.02	±0.03	%/°C
Over Current Protection	input voltage range		110	140	--	%Io
Over Voltage Protection			110	--	160	%Vo
Short-circuit Protection			Continuous, Self-Recovery			

General Specifications

Item	Operating Conditions	Min.	Typ.	Max.	Unit
Insulation Voltage	Input-output, test time 1 minute, leakage current less than 1mA	1500	--	--	VDC
Insulation Resistance	Input-output, insulated voltage 500VDC	1000	--	--	MΩ
Isolation Capacitance	Input-output, 100KHz/0.1V	--	120	--	pF
Operating Temperature	Derating when operating temperature ≥ 85°C (See Figure 1)	-40	--	85	°C
Storage Temperature		-55	--	125	
Storage Humidity	Non-condensing	--	--	95	%RH
Pin welding can withstand the highest temperature	Soldering spot is 1.5mm away from case for 10 seconds	--	--	300	°C
Switching Frequency	Full Load, Nominal Input Voltage	--	200	--	kHz
MTBF	MIL-HDBK-217F@25°C	>1000Kh			

Mechanical Specifications

Case Material	Aluminum alloy, black anodized coating
Package Dimensions	32.00 * 20.00 * 11.0 mm
Weight	14.3g(Typ.)
Cooling Method	Free air convection

EMC Specifications

EMI	CE	CISPR32/EN55032 CLASS A(open board)/CLASS B (application circuit 3-②)	
	RE	CISPR32/EN55032 CLASS A(open board)/CLASS B (application circuit 3-②)	
EMS	ESD	IEC/EN61000-4-2 Contact±4KV	Perf.Criteria B
	RS	IEC/EN61000-4-3 10V/m	Perf.Criteria A
	EFT	IEC/EN61000-4-4 ±2KV(application circuit3-①)	Perf.Criteria B
	Surge	IEC/EN61000-4-5 line to line±2KV(application circuit3-①)	Perf.Criteria B
	CS	IEC/EN61000-4-6 3 Vr.m.s	Perf.Criteria A

Typical Characteristic Curves

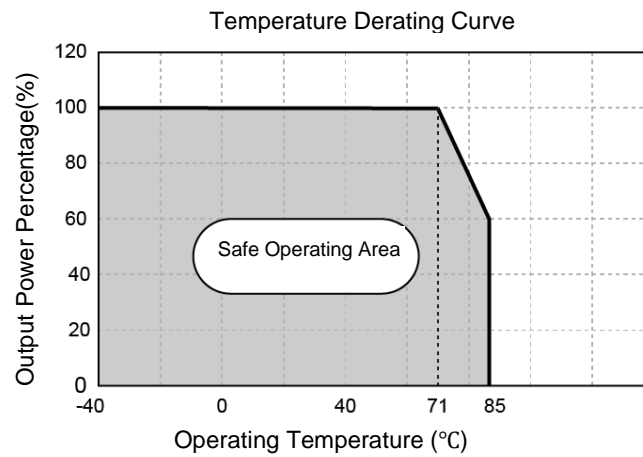
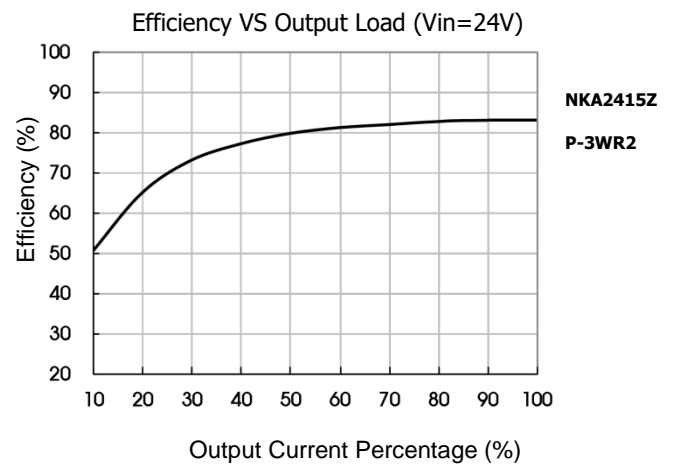
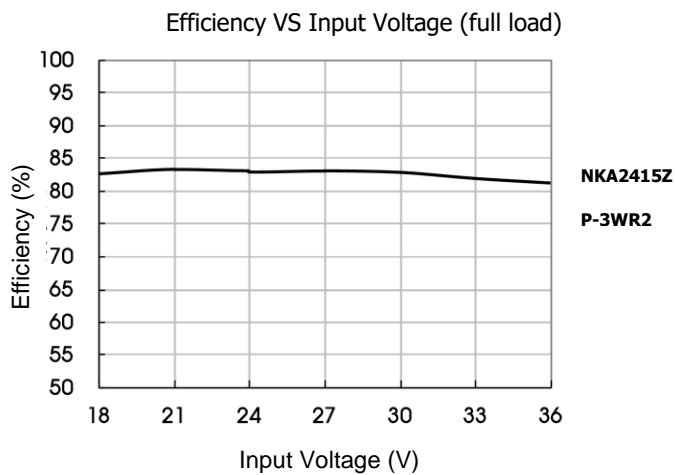
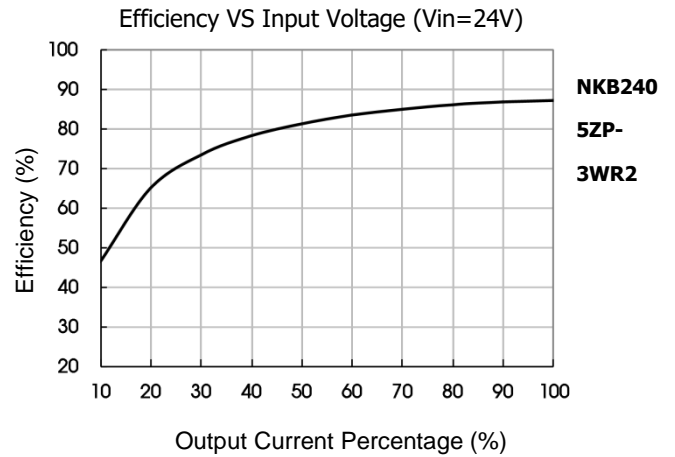
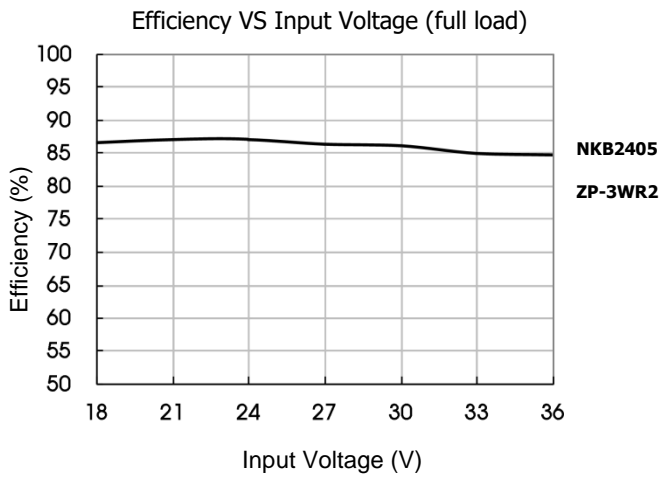

Figure 1





Circuit Design and Application

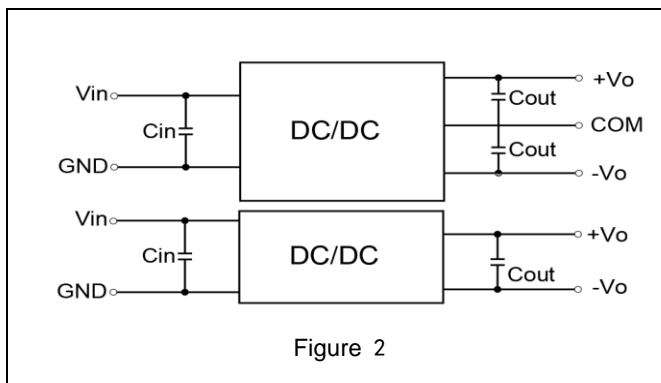

Figure 2

Recommended Capacitive Load Value Table		
Vin(VDC)	Cin	Cout
5	100μF/ 16V	Vo(3/±3/5/±5/9/±9):10μF/ 16V Vo(12/±12/ 15/±15V):10μF/25V Vo(24/±24V):10μF/50V
12	100μF/25V	
24	10μF/50V ~47μF/50V	
48	10μF/ 100V ~47μF/ 100V	

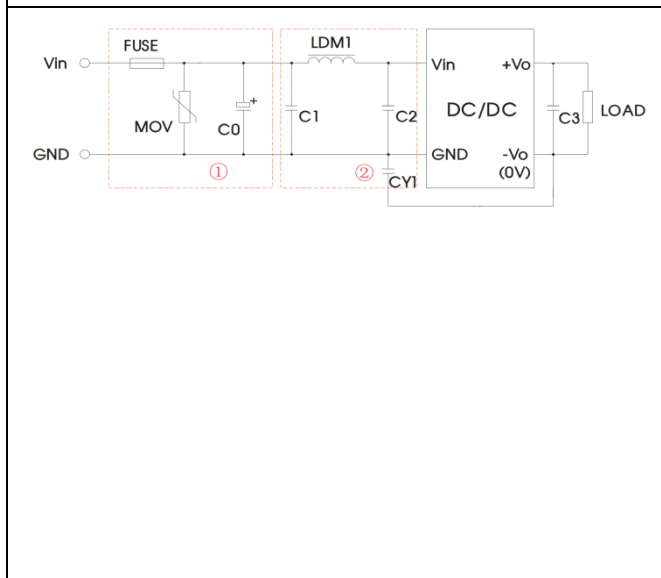

Figure 3

EMI Recommended Parameter Table				
Model	Vin:5VD C	Vin:12VD C	Vin:24VDC	Vin:48VDC
FUSE	Select according to the actual input current of the customer			
MOV	--	14D330K	20D470K	14D101K
C0	1000μF	1000μF/	330μF/50	330μF/ 100V
C1	4.7μF/50V		4.7μF/ 100V	
LDM1	12μH			
C2	4.7μF/50V		4.7μF/ 100V	
C3	Refer to Figure 2 Cout parameter			
CY1	1nF/2kV			

Note: Part 1 in Figure 3 is for EMC testing;
The second part is used for EMI filtering, which can be selected according to the demand.

Application circuit

All DC/DC converters of this series are tested according to the recommended test circuit (Figure 2) before leaving the factory.

If it is required to further reduce the input and output ripple, the input and output external capacitors C_{in1} , C_{in2} , C_s , C_{out} can be increased or a capacitor with a small series equivalent impedance value can be selected. C_s is used to reduce the ripple, and if the ripple is to meet the demand, there is no need to add C_s . However, the appropriate filter capacitor should be selected, if the capacitor is too large, it is likely to cause startup problems. For each output, under safe and reliable working conditions, the maximum capacitance of the filter capacitance cannot be greater than the maximum capacitive load of the product.

Dimensions and Recommended Layout

Dimensions

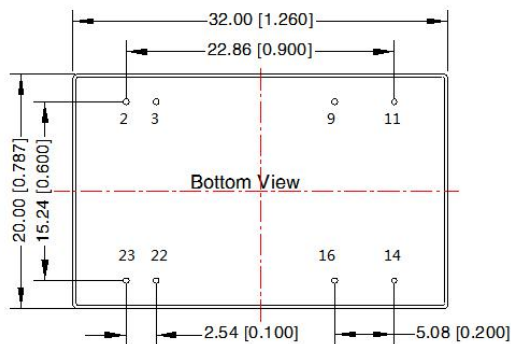
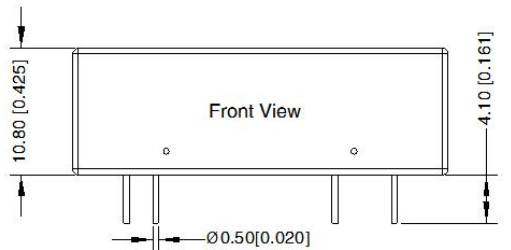

Note:
 Unit: mm[inch]
 Pin diameter tolerances: $\pm 0.10 [\pm 0.004]$
 General tolerances: $\pm 0.50 [\pm 0.020]$

PCB Printing Layout & Pin Definition Table

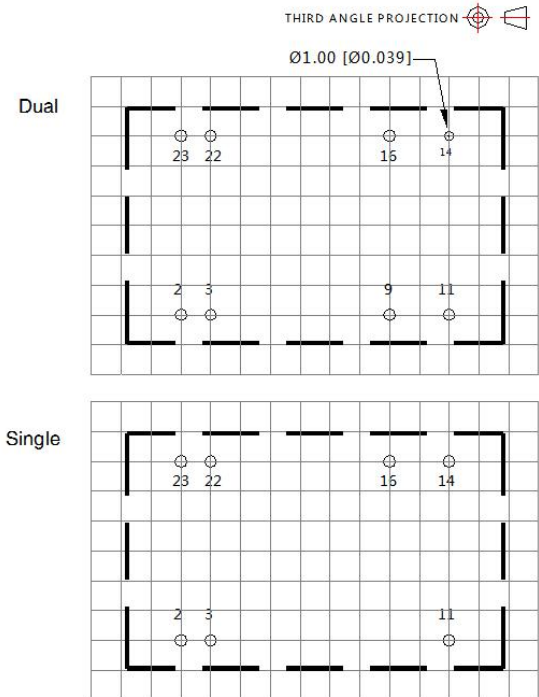

Note: Grid 2.54*2.54mm

Pin	Pin-Out	
	Single	Dual
2,3	GND	GND
9*	No Pin	0V
11	NC	-Vo
14	+Vo	+Vo
16	0V	0V
22,23	Vin	Vin

* Note: 5V input product without 9th pin
 NC: Pin to be isolated from circuit

Note:

1. If the product works under the minimum required load, it cannot guarantee that the performance of the product complies with all the performance indicators in this manual;
2. The maximum capacitive load is tested under the input voltage range and full load condition;
3. Unless otherwise stated, all indexes in this manual are measured at $T_a=25^\circ\text{C}$, humidity $<75\%RH$, nominal input voltage and rated output load;