

- Compact design in THD Package
- Ultra wide 4:1 input voltage range
- Fully regulated outputs
- Low ripple and noise
- Temperature range -40°C to $+85^{\circ}\text{C}$ without derating
- I/O isolation 1600 VDC
- Continuous short-circuit protection
- Remote On/Off control
- Fully RoHS compliant
- 3-year product warranty

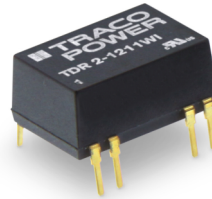

The TDR 2WI series is a family of compact 2 W DC/DC-converters with 4:1 input voltage ranges and tightly regulated output voltages even under no load conditions. The product is available in THD-package. They work with high efficiency over the full load range and come with a remote On/Off input. The usability in temperature ranges of up to 85°C without power derating, continuous short circuit protection and excellent immunity against environmental influences make these converters very reliable. A TDR 2WI converter is the ideal solution for space critical high end applications in communication equipment, instrumentation and industrial electronics.

Models						
Order Code	Input Voltage Range	Output 1		Output 2		Efficiency typ.
		Vnom	I _{max}	Vnom	I _{max}	
TDR 2-1211WI	4.5 - 18 VDC (12 VDC nom.)	5 VDC	400 mA			79 %
TDR 2-1212WI		12 VDC	167 mA			80 %
TDR 2-1213WI		15 VDC	134 mA			81 %
TDR 2-1222WI		+12 VDC	83 mA	-12 VDC	83 mA	81 %
TDR 2-1223WI		+15 VDC	67 mA	-15 VDC	67 mA	81 %
TDR 2-2411WI	9 - 36 VDC (24 VDC nom.)	5 VDC	400 mA			79 %
TDR 2-2412WI		12 VDC	167 mA			80 %
TDR 2-2413WI		15 VDC	134 mA			82 %
TDR 2-2422WI		+12 VDC	83 mA	-12 VDC	83 mA	81 %
TDR 2-2423WI		+15 VDC	67 mA	-15 VDC	67 mA	81 %
TDR 2-4811WI	18 - 75 VDC (48 VDC nom.)	5 VDC	400 mA			78 %
TDR 2-4812WI		12 VDC	167 mA			81 %
TDR 2-4813WI		15 VDC	134 mA			82 %
TDR 2-4822WI		+12 VDC	83 mA	-12 VDC	83 mA	81 %
TDR 2-4823WI		+15 VDC	67 mA	-15 VDC	67 mA	81 %

Input Specifications

Input Current	- At no load	12 Vin models: 35 mA typ. 24 Vin models: 20 mA typ. 48 Vin models: 10 mA typ.
	- At full load	12 Vin models: 215 mA max. 24 Vin models: 110 mA max. 48 Vin models: 55 mA max.
Surge Voltage		12 Vin models: 25 VDC max. (1 s max.) 24 Vin models: 50 VDC max. (1 s max.) 48 Vin models: 100 VDC max. (1 s max.)
Reflected Ripple Current		12 Vin models: 80 mA_{p-p} typ. 24 Vin models: 40 mA_{p-p} typ. 48 Vin models: 30 mA_{p-p} typ.
Recommended Input Fuse		12 Vin models: 1'600 mA (slow blow) 24 Vin models: 1'000 mA (slow blow) 48 Vin models: 1'000 mA (slow blow) (The need of an external fuse has to be assessed in the final application.)
Input Filter		Internal Capacitor

Output Specifications

Voltage Set Accuracy		±1% max.
Regulation	- Input Variation (V _{min} - V _{max})	single output models: 0.2% max. dual output models: 0.2% max.
	- Load Variation (0 - 100%)	single output models: 1% max. dual output models: 1% max. (Output 1) 1% max. (Output 2)
	- Cross Regulation (25% / 100% asym. load)	dual output models: 5% max.
Ripple and Noise	- 20 MHz Bandwidth	30 mV_{p-p} typ.
Capacitive Load	- single output	5 V _{out} models: 1'680 μF max. 12 V _{out} models: 820 μF max. 15 V _{out} models: 680 μF max.
	- dual output	12 / -12 V _{out} models: 470 / 470 μF max. 15 / -15 V _{out} models: 330 / 330 μF max.
Minimum Load		Not required
Temperature Coefficient		±0.02 %/K max.
Start-up Time		5 ms typ.
Short Circuit Protection		Continuous, Automatic recovery
Transient Response	- Response Time	250 μs typ. (25% Load Step)

Safety Specifications

Standards	- IT / Multimedia Equipment	EN 60950-1 EN 62368-1 IEC 60950-1 IEC 62368-1 UL 60950-1 UL 62368-1
	- Certification Documents	www.tracopower.com/overview/tdr2wi
Pollution Degree		PD 2

All specifications valid at nominal voltage, resistive full load and +25°C after warm-up time, unless otherwise stated.

EMC Specifications

EMI (Emissions)	- Conducted Emissions	EN 55032 class A (with external filter) EN 55032 class B (with external filter)
	- Radiated Emissions	EN 55032 class A (with external filter) EN 55032 class B (with external filter)
		External filter proposal: www.tracopower.com/overview/tdr2wi
EMS (Immunity)	- Electrostatic Discharge	Air: EN 61000-4-2, ±8 kV, perf. criteria A Contact: EN 61000-4-2, ±6 kV, perf. criteria A
	- RF Electromagnetic Field	EN 61000-4-3, 10 V/m, perf. criteria A
	- EFT (Burst) / Surge	EN 61000-4-4, ±2 kV, perf. criteria A EN 61000-4-5, ±1 kV, perf. criteria A
	- Conducted RF Disturbances	Ext. input component: 220 µF / 100 V EN 61000-4-6, 10 Vrms, perf. criteria A
	- PF Magnetic Field	Continuous: EN 61000-4-8, 100 A/m, perf. criteria A 1 s: EN 61000-4-8, 1000 A/m, perf. criteria A

General Specifications

Relative Humidity		95% max. (non condensing)
Temperature Ranges	- Operating Temperature	-40°C to +85°C (without derating)
	- Case Temperature	+100°C max.
	- Storage Temperature	-55°C to +125°C
Power Derating	- High Temperature	6.67 %/K above 85°C
	See application note: www.tracopower.com/overview/tdr2wi	
Cooling System		Natural convection (20 LFM)
Remote Control	- Current Controlled Remote (passive = on)	On: open circuit Off: 2 to 4 mA current (internal 1 kΩ resistor) Refers to 'Remote' and '-Vin' Pin
	- Off Idle Input Current	External circuit proposal: www.tracopower.com/info/current-remote.pdf 2.5 mA max.
Altitude During Operation		5'000 m max.
Regulator Topology		Flyback Converter
Switching Frequency		100 - 2500 kHz (RCC)
Insulation System		Basic Insulation
Isolation Test Voltage	- Input to Output, 60 s	1'600 VDC
Isolation Resistance	- Input to Output, 500 VDC	1'000 MΩ min.
Isolation Capacitance	- Input to Output, 100 kHz, 1 V	50 pF max.
Reliability	- Calculated MTBF	6'600'000 h (MIL-HDBK-217F, ground benign)
Washing Process		According to Cleaning Guideline www.tracopower.com/info/cleaning.pdf
Environment	- Vibration	MIL-STD-810F
	- Thermal Shock	MIL-STD-810F
Housing Material		Non-conductive Plastic (UL 94 V-0 rated)
Potting Material		Epoxy (UL 94 V-0 rated)
Pin Material		Copper
Pin Foundation Plating		Nickel (40 - 120 µm)
Pin Surface Plating		Gold (25 - 75 nm), matte
Housing Type		Overmold
Mounting Type		PCB Mount
Connection Type		THD (Through-Hole Device)
Footprint Type		DIP14
Soldering Profile		Lead-Free Wave Soldering
		265°C / 10 s max.
Weight		4.5 g

All specifications valid at nominal voltage, resistive full load and +25°C after warm-up time, unless otherwise stated.

Environmental Compliance - REACH Declaration

www.tracopower.com/info/reach-declaration.pdf

- RoHS Declaration

REACH SVHC list compliant

REACH Annex XVII compliant

www.tracopower.com/info/rohs-declaration.pdf

Exemptions: 7(a), 7(c)-I

(RoHS exemptions refer to the component concentration only, not to the overall concentration in the product (O5A rule))

- SCIP Reference Number

8b56c5d9-e830-4752-ba79-df2af3e247fd

Additional Information

Supporting Documents

www.tracopower.com/overview/tdr2wi

Frequently Asked Questions

www.tracopower.com/glossary-faq

Glossary

www.tracopower.com/info/glossary.pdf

Outline Dimensions

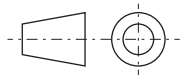

Dimensions in mm (inch)
Tolerances: ± 0.5 (± 0.02)
Pin pitch tolerances ± 0.25 (± 0.01)

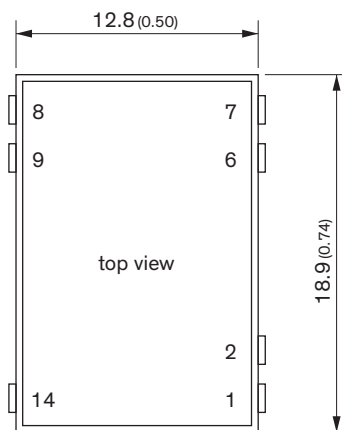
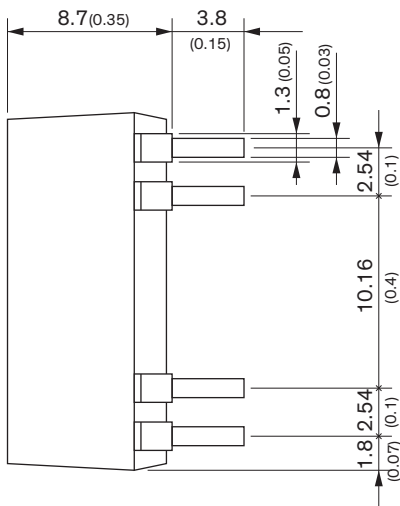
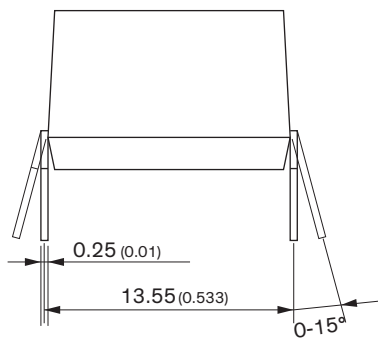

Pinout

Pin	Single	Dual
1	-Vin (GND)	-Vin (GND)
2	Remote On/Off	Remote On/Off
6	NC	Common
7	NC	-Vout
8	+Vout	+Vout
9	-Vout	Common
14	+Vin (Vcc)	+Vin (Vcc)

NC: Not connected