

FEATURES

1. Package Type: 1"X 1"
2. Operating temperature range: -40°C - +105°C
3. Isolation voltage: 1500VDC
4. High efficiency up to 91%
5. The mechanism has input undervoltage protection, output short circuit protection and over current protection
6. 4:1 Ultra-wide input voltage range
7. Fields of application: Power, industrial control, communications, Internet of Things, automotive, etc



**3 years
Warranty**

Selection Guide

Part No.	Input Voltage (VDC)		Output		Full Load Efficiency% (min/Typ.)	Capacitive Load(μF) Max.
	Nominal (Range)	Maximum	Voltage (VDC)	Current (mA)		
ZYB2403YMD-15WR3	24 (9-36)	40	3.3	4000/0	86/88	4700
ZYB2405YMD-15WR3			5	3000/0	88/90	4700
ZYB2412YMD-15WR3			12	1250/0	88/90	1000
ZYB2415YMD-15WR3			15	1000/0	89/91	820
ZYB2424YMD-15WR3			24	625/0	89/91	270
ZYA2405YMD-15WR3			±5	±1500/0	85/87	#1500
ZYA2412YMD-15WR3			±12	±625/0	88/90	#470
ZYA2415YMD-15WR3			±15	±500/0	88/90	#330
ZYA2424YMD-15WR3			±24	±312/0	86/88	#200
ZYB4803YMD-15WR3	48 (18-75)	80	3.3	4000/0	86/88	4700
ZYB4805YMD-15WR3			5	3000/0	88/90	4700
ZYB4812YMD-15WR3			12	1250/0	89/91	1000
ZYB4815YMD-15WR3			15	1000/0	89/91	820
ZYB4824YMD-15WR3			24	625/0	89/91	270
ZYA4805YMD-15WR3			±5	±1500/0	84/86	#1500
ZYA4812YMD-15WR3			±12	±625/0	87/89	#470
ZYA4815YMD-15WR3			±15	±500/0	87/89	#330
ZYA4824YMD-15WR3			±24	±312/0	88/90	#200

#each output

Input Specifications

Item	Operating Conditions	Min.	Typ.	Max.	Unit	
Input Current(full load/no-load)	24VDC nominal input series	3.3VDC	--	625/30	640/50	mA
		5VDC	--	694/30	710/50	
		12VDC	--	694/6	710/15	
		15VDC	--	687/6	703/15	
		24VDC	--	687/10	703/20	
	48VDC nominal input series	3.3VDC	--	313/15	320/30	
		5VDC	--	348/15	356/30	
		12VDC	--	344/3	352/11	
		15VDC	--	344/3	352/11	
		24VDC	--	344/4	352/11	
Reflected Ripple Current	nominal input series	--	30	--		
Impulse Voltage	24VDC nominal input series	-0.7	--	50	VDC	
	48VDC nominal input series	-0.7	--	100		
Starting Voltage	24VDC nominal input series	--	--	9		
	48VDC nominal input series	--	--	18		
Input undervoltage protection	24VDC nominal input series	5.5	6.5	--		
	48VDC nominal input series	12.0	15.5	--		
Ctrl	turn off module	connected GND or (0-1.2V)				
	turn on module	No connected or (3.5-12V)				
	Input current when off	--	2	7	mA	
Input Filter		PI filter				

Output Specifications

Item	Operating Conditions	Min.	Typ.	Max.	Unit
Output Voltage Accuracy	0%-100% load	--	±1.0	±3.0	%
Linear Regulation	Vin=Min. to Max. @Full Load	--	±0.2	±0.5	
Load Regulation	5%-100% load	--	±0.5	±1.0	
Ripple & Noise	20MHz bandwidth,100% load	--	50	100	mVp-p
Transient Recovery Time	25% Load Step Change,nominal input voltage	--	300	500	µs
Transient Response Deviation		--	±3	±8	%
Temperature Coefficient	Full Load	--	±0.01	±0.02	%/°C
Trim	input voltage range	90	--	110	%
Over Voltage Protection		110	--	160	%
Over Current Protection		110	150	190	%
Short-Circuit Protection		Continuous, Self-Recovery			

General Specifications

Item	Operating Conditions	Min.	Typ.	Max.	Unit	
Isolation Voltage	Input-output, test time 1 minute, leakage current less than 1mA	1500	--	--	VDC	
Insulation Resistance	Input-output, insulated voltage 500VDC	1000	--	--	MΩ	
Isolation Capacitance	Input-output, 100KHz/0.1V	--	2000	--	pF	
Operating Temperature	See Fig 1	3.3V、5VDC	-40	--	+95	°C
		Others	-40	--	+105	
Storage Temperature		-50	--	+125		
Storage Humidity	Non-condensing	--	--	95	%RH	
Soldering Profile	1.5mm from case for 10 sec	--	--	300	°C	
Switching Frequency	Full load, nominal input voltage	--	300	--	kHz	
MTBF	MIL-HDBK-217F@25°C	1000			K Hours	

Mechanical Specifications

Case Material	Aluminum alloy
Package Dimensions	25.4mm * 25.40mm * 12.00 mm
Weight	15.65g(Typ.)
Cooling Method	Free air convection

EMC Specifications

EMI	CE	CISPR32/EN55032 CLASS A (without external components)/CLASS B (see Fig.3-② for recommended circuit)	
	RE	CISPR32/EN55032 CLASS A (without external components)/CLASS B (see Fig.3-② for recommended circuit)	
EMS	ESD	IEC/EN61000-4-2 Contact±6KV/Air ±8KV	perf. Criteria B
	RS	IEC/EN61000-4-3 10V/m	perf. Criteria A
	EFT	IEC/EN61000-4-4 ±2KV(see Fig.3-① for recommended circuit)	perf. Criteria B
	Surge	IEC/EN61000-4-5 line to line±2KV(see Fig.3-① for recommended circuit)	perf. Criteria B
	CS	IEC/EN61000-4-6 3 Vr.m.s	perf. Criteria A

Typical Characteristic Curves

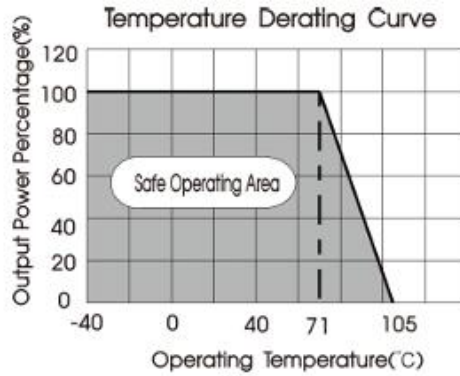
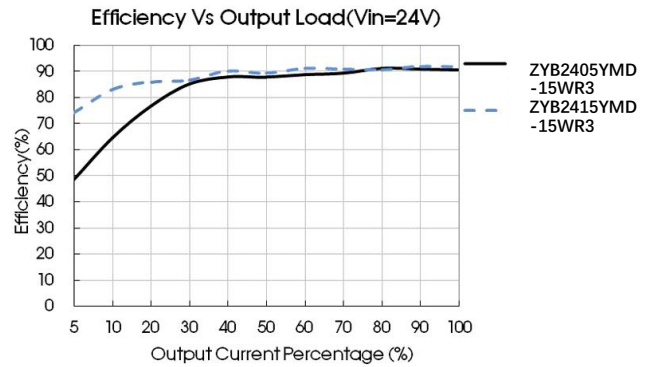
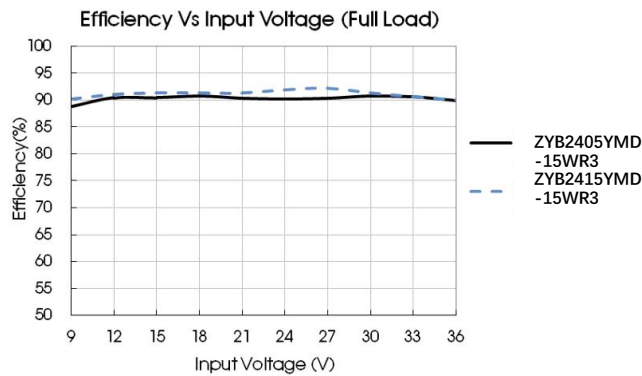
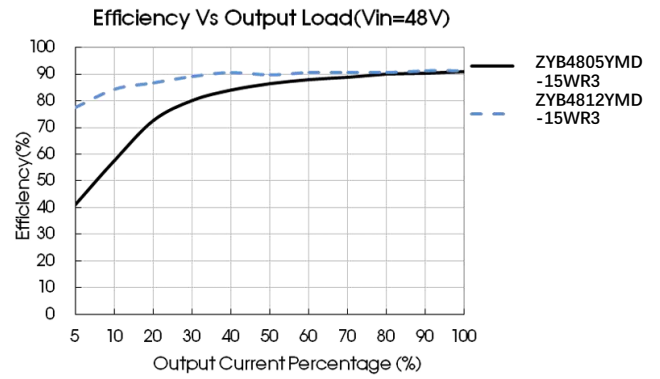
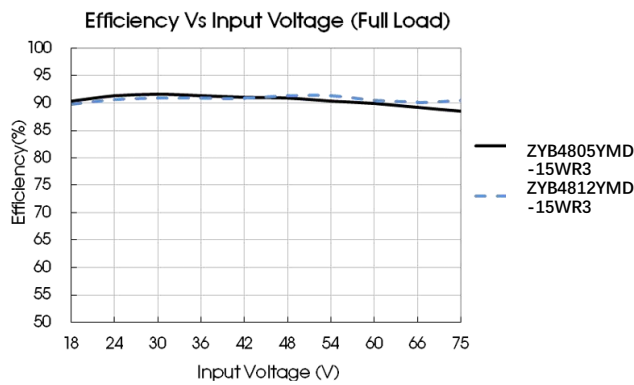

Fig. 1



Typical Circuit Design And Application

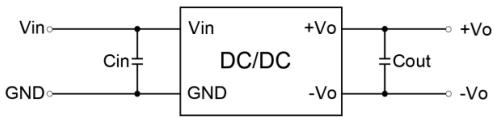

Fig 2

Recommended component parameters

Vout(VDC)	Cin(uF)	Cout(uF)
3.3/5/12/15	100uF	100uF
24		47uF

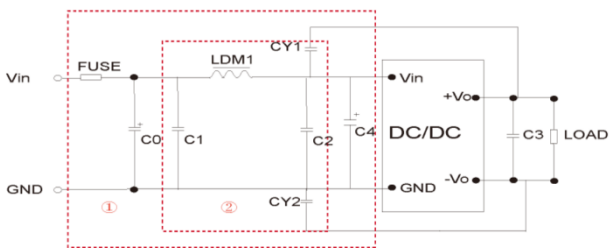
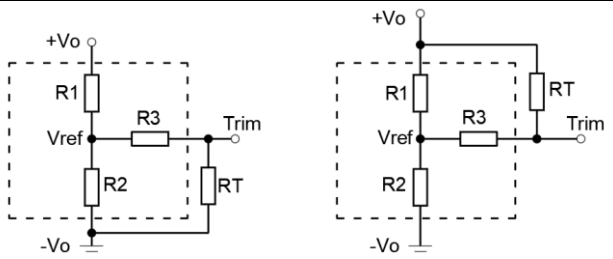

Fig 3

EMI recommended component parameters

Model	Vin:24V	Vin:48V
FUSE	Choose according to actual input current	
C0、C4	330μF/50V	330μF/100V
C1、C2	4.7μF/50V	4.7μF/100V
C3	Refer to the Cout in Fig.2	
LDM1	2.2uH/4A	2.2uH/2A
CY1、CY2	1nF/2KV	



Trim up Trim down

Trim resistor connections (dashed line shows internal resistor network)

Trim

Vout(V)	R1(KΩ)	R2(KΩ)	R3(KΩ)	Vref(V)
3.3	10	6.064	13.622	1.24
5	2.4	2.344	13.622	2.5
12	8.2	2.153	17.346	2.5
15	12	2.388	21.016	2.5
24	10	1.158	10.714	2.5

Up: $R_t = \frac{nR_2}{R_2 - n} - R_3$ $n = \frac{V_{ref}}{V_o - V_{ref}} * R_1$
 Down: $R_t = \frac{nR_1}{R_1 - n} - R_3$ $n = \frac{V_o - V_{ref}}{V_{ref}} * R_2$

All DC-DC converters of this series are tested before delivery using the recommended circuit shown in Fig. 2. Input and/or output ripple can be further reduced by appropriately increasing the input & output capacitor values C_{in} and C_{out} and/or by selecting capacitors with a low ESR (equivalent series resistance). Also make sure that the capacitance is not exceeding the specified max. capacitive load value of the product.

Dimensions and Recommended Layout

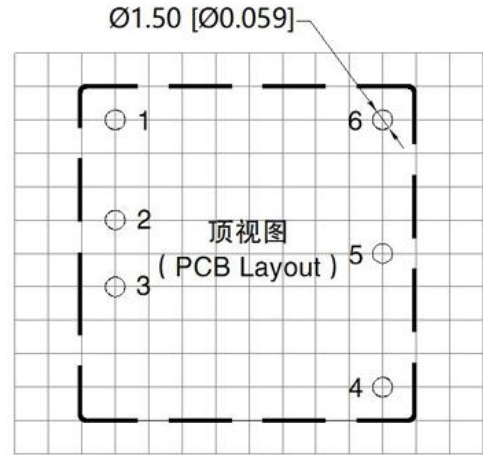
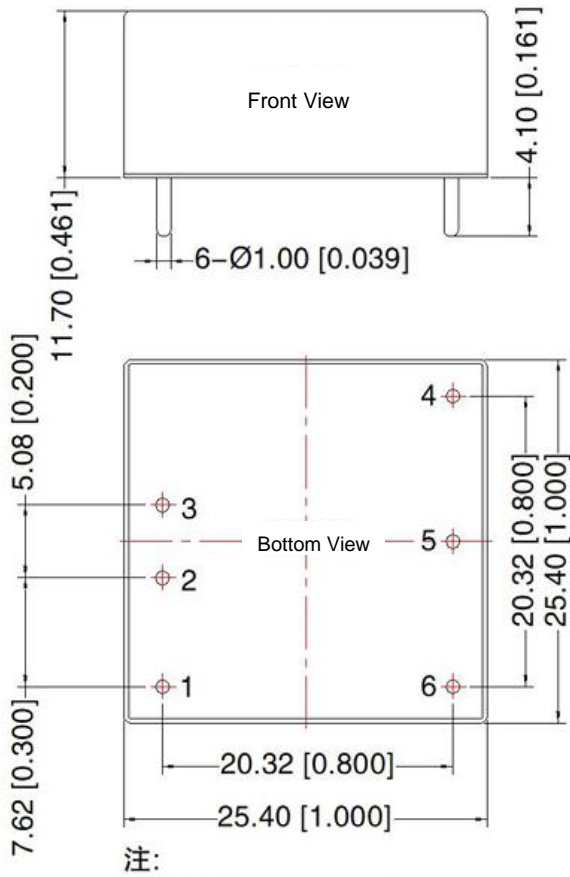

Pin	Function(S)	Function(D)
1	Ctrl	Ctrl
2	GND	GND
3	Vin	Vin
4	+Vo	+V0
5	Trim	Trim
6	0V	-Vo

Note:

Unit: mm[inch]

Pin section tolerances:±0.10[±0.004]

General tolerances:±0.50[±0.020]

Note: The grid distance is 2.54*2.54mm

Notes & Instructions

1. If the product works under the minimum required load, it cannot guarantee that the performance of the product complies with all the performance indicators in this manual;
2. The maximum capacitive load is tested under the input voltage range and full load condition;
3. Unless otherwise stated, all indexes in this manual are measured at Ta=25°C, humidity <75%RH, nominal input voltage and rated output load;
4. All index testing methods in this manual are based on the enterprise standards of the company;
5. Our company can provide product customization, specific needs can directly contact our technical staff;