

MATERIAL:

- 1.HOUSING: LCP, GLASS FIBER FILLED, BK
- 2.CONTACT: COPPER ALLOY
- 3.GUARD PLATE:STAINLESS STEEL
- 4.SHIELD: STAINLESS STEEL

FINISH:

- CONTACT: SEE ORDER INFORMATION  
SHELL: NICKEL PLATING

Ordering Code:

CU32 24 S \* S A L R 001 -LF

① ② ③ ④ ⑤ ⑥ ⑦ ⑧ ⑨ ⑩

- ① Series No:CU32
- ② No. of Circuits: 24Pin
- ③ Contact type: S=Socket
- ④ Plating option:  
A= Gold flash plated on Contact area,  
Matte Tin plated on Solderetails,  
Nickel underplating over all
- ⑤ Shell Material & Plating: S= STAINLESS STEEL
- ⑥ Contact Material: A= COPPER ALLOY
- ⑦ Insulator Material & Color option:  
L= LCP Black
- ⑧ Packing: R= Tape & Reel
- ⑨ Other option: 001
- ⑩ -LF=For Lead Free IR Reflow Process

Lead Free Process

RoHS Compliant

CVILUX COUP  
2021.08.12  
ISSUED

④					DATE	UNIT: mm / inch	TITLE: CU32 TYPE C/F 24 PIN CH=1.68mm SMT TYPE TOP MOUNT TYPE	 瀚荃股份有限公司 CviLux Corporation	
③				DRAWN BY: Annie	07/30-21'	TOLERANCE UNLESS OTHERWISE SPECIFIED	MATERIAL:		
②				ENGINEER: Gavin	07/30-21'	.X ± 0.25/.010 X' ± 4'	FINISH:		
①				CHECKED BY: Keny	07/30-21'	.XX ± 0.20/.008 X' ± 2'			
SYM	NAME	DATE	REVISIONS	APPROVED BY: Keny	07/30-21'	.XXX ± 0.10/.004 .XX' ±	DRAWING NO. CU32S01SA	PART NO. CU3224S*SALR001-LF	
								SCALE 4 / 1	SHEET 1 OF 3



NOTE :

- \* Reel Material : HIPS
- \* Carrier Material : Clear, Conductive Polystyrene Alloy
- \* Cover Tape Material : Polyester
- \* Cover Tape Peel Strength : 0.1N – 1.3N
- \* Carrier camber is within 1mm in 250mm
- \* All dimensions meet EIA-481-B requirements.
- \* Quantity : 900 PCS/Reel

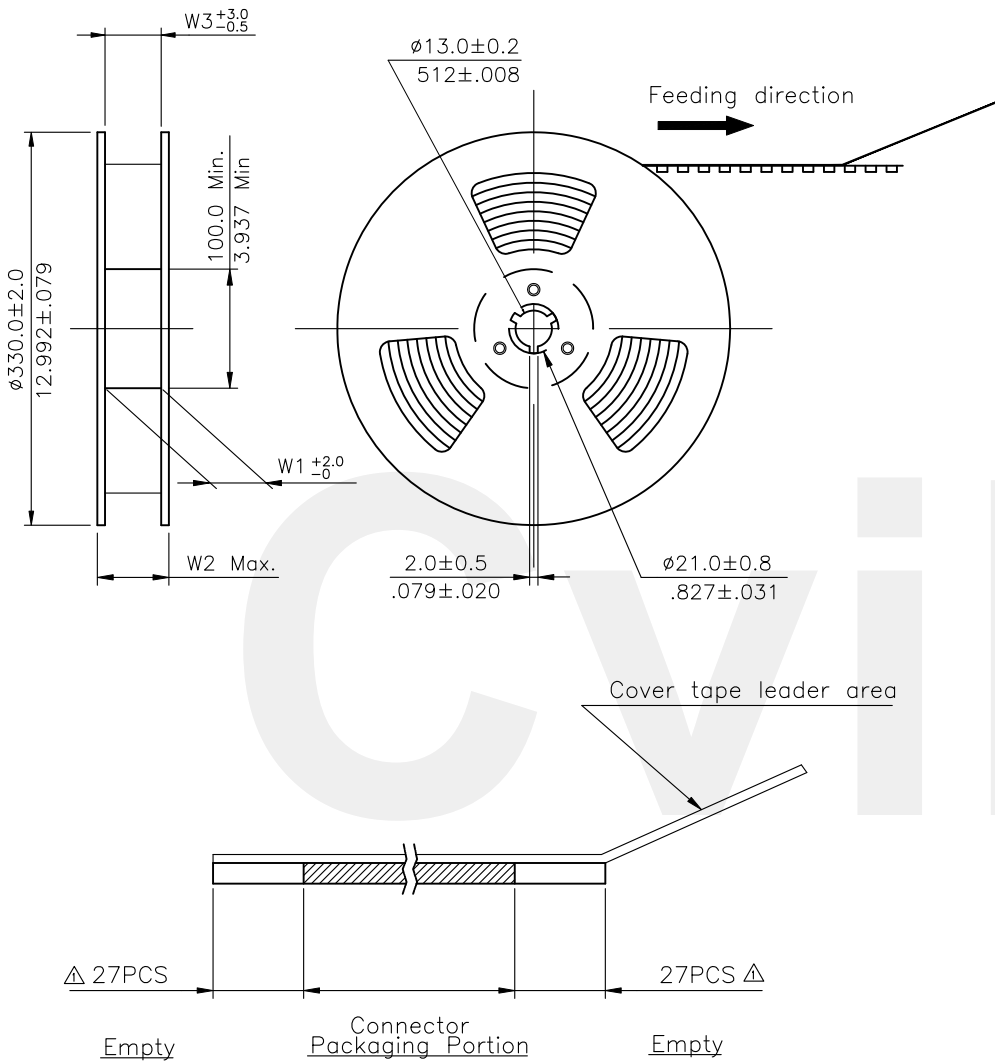

Dimension				Packing (Reel/Carton)
E	W1	W2	W3	
24.0(.945)	24.5(.965)	30.5(1.201)	24.5(.965)	10

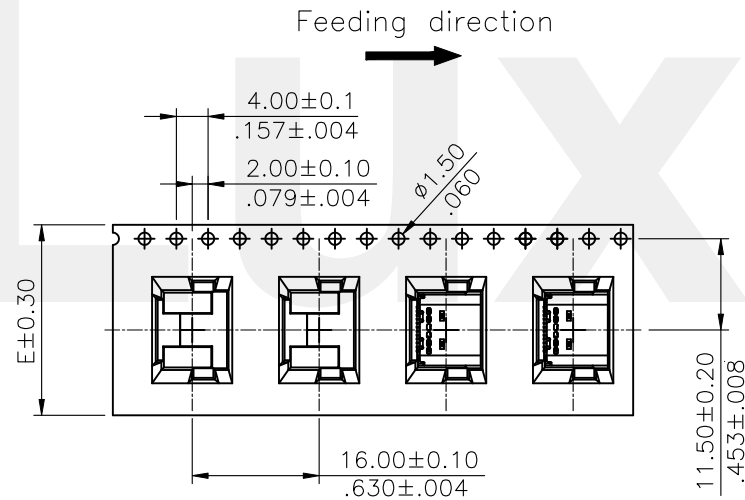

WIDTH : 24 mm Carrier

Lead Free Process

RoHS Compliant



SYM	NAME	DATE	REVISIONS	APPROVED BY:	DATE	UNIT: mm / inch	TITLE: CU32 TYPE C/F 24 PIN CH=1.68mm SMT TYPE TOP MOUNT TYPE
4							
3				DRAWN BY:	Annie	07/30-21'	MATERIAL:
2				ENGINEER:	Gavin	07/30-21'	
1				CHECKED BY:	Keny	07/30-21'	FINISH:
				APPROVED BY:	Keny	07/30-21'	



瀚荃股份有限公司  
CviLux Corporation

DRAWING NO.	CU32S01SA	PART NO.	CU3224S*SALR001-LF
SCALE		SHEET	3 OF 3