

领先的扎带/配线器材服务商

Leading cable tie / wiring accessories and services provider

HONT[®]



公司地址：中國宏泰電器有限公司

座落于國家級風景秀麗的雁蕩山景區，
中國電器之都—柳市，峽門工業區

董事長：王旭飛 **創建日期：**1997年

注冊資金：5100萬 **廠房面積：**45000平方米

主要設備：全電腦大型注塑機88臺，衝床30臺，
UL 認證實驗室，全自動抽氣注水封口機。

主營產品：自鎖式尼龍扎帶，各種款式尼龍扎帶，
不銹鋼扎帶，鋼釘綫卡，接綫端子，冷壓端頭，
電動工具開關等產品。

公司證書：1998年通過了ISO9001國際質量體認證

2001年通過了TUV認證

2002年通過了CE認證

2003年通過了美國UL認證

2005年通過了SGS認證

2009年通過了ROHS 及 REACH 認證

2010年電動工具開關取得UL 及 TUV 認證

2014年自主研發加強型扎綫帶獲得國家發明專利。

2016年自主研發自鎖式雙面扎綫帶獲得國家發明專利。

2017年自主研發分體金屬嵌片扎綫帶、
增強金屬嵌片扎綫帶并獲得國家發明專利及國際專利。

2018年自主研發可鬆式末端約束式扎綫帶、
硅膠扎綫帶獲得國家發明專利及國際專利、
企業榮獲國家“高新技術企業”稱號。

2019年申請BSCI認證。

產品研發：獨立研發各種塑料，衝制產品

公司宗旨：竭誠奉獻，卓越品質，基業長青，永續經營

合作公司：HOME DEPOT, GB, KINGFISHER, WALMART,
STANLEY, RB, MENARD, CARREFOUR,
DORMAM, MAKITA, OFFICE DEPOT.

Address: Hont Electrical Co.,Ltd,

located in Yandang scenic spots, the city of
Chinese electrical-Liushi. Xiamen Industrial Zone.

Chairman: Wang Xufei

Found Date: 1997

Registration Fund: RMB51,000,000.00

Work Shop: 45000 m²

Main Equipment: 88 large scale full computerized injection
mold machine, 30 punches, UL recognized Lab, Automatic
Vacuum Water-Injection seamer.

Main products: Self Locking Nylon Cable Tie, Special Kinds
of Cable Tie, Stainless Steel Cable Tie, Nail Cable Clips,
Terminal Block, Cold-pressed Terminal, Power Tools Switch.
Certification: ISO9001(1998) TUV(2001) CE(2002)
UL(2003) SGS(2005) RoHS REACH(2009) UL&TUV for
Power Tools Switch(2010) In 2014, 2016, independent
research and development of cable tie with access to the
national invention patent.

2017 independent research and development of separate
type embedded cable tie, enhanced easy-to-wear metal
insert cable tie with access to national invention patent and
international patent.

2018 independent research and development of releasable
restrain the end cable tie, silicone cable tie with access to
national invention patent and international patent. Company
obtain the title of high-technology enterprises.

2019 Application for BSCI Certification.

R&D: Research and Development the plastic and punching
Products independently.

Tenet: Best Service, Best Quality, Enterprise Evergreen,
Continuance Business.

Co-operative Company: HOME DEPOT, GB,
INGFISHER, WALMART, STANLEY, RB, MENARD,
CARREFOUR, DORMAM, MAKITA, OFFICE DEPOT.

UL
E225994

TUV
PRODUCT SERVICE

SGS
RoHS
Certificate

ISO 9001:2000 SGS

CE

RoHS

PAHs

Reach

科技铸就品牌，宏泰与你共创美好未来...

Technology creates brand, Fergus with you to create a better future...



技术中心作为公司新产品研究与开发的中枢，具备完善的研究与开发的能力。创新进取精神是一个企业发展的永恒动力，宏泰将永远支持创新精神，永不安于现状。企业将在完善现有产品基础上，不断创新生产技术，发展各种优质的新产品以适合市场需要，增强企业的核心竞争力。

As the backbone of research and development of new products, the technical center has owned strong ability to research and develop. The determined and enterprising spirit is the everlasting power of an enterprise development, so the HONT encourages and supports this spirit for ever and keeps improving. Basing on perfecting current products, Company's innovative production technology, develops new products of top quality to meet market demands, and strengthen the core competitive power of enterprise.



▶ 全自动注塑加工中心
Automatic Injection Molding Machining Center



▶ 全自动抽气注水封口机,已申请专利201120305543.6
Automatic Vacuum Water-Injection seamer Has applied for patent 201120305543. 6



▶ 全自动机械手
Automatic arm



▶ 注塑加工车间一角
Corner of injection molding workshop



▶ 拉力试验机/高低温试验箱
Tensile testing machine/High and low temperature experiment box



▶ UL-94 塑料燃烧试验机
UL-94 plastic combustion tester

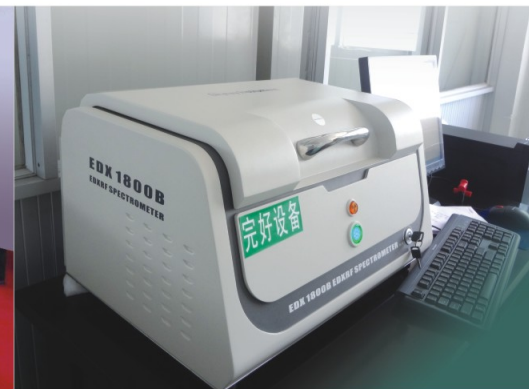

▶ RoHS测试设备(EDX1800B)
RoHS Test Edxrf Spectrometer



▶ 高低温试验箱
High and low temperature experiment box



▶ 水份测试仪
Moisture tester



▶ Ascend 品牌材料供应商



▶ Dupont 品牌料供应商



▶ 自动铆线卡机
Automatic riveting machine line card

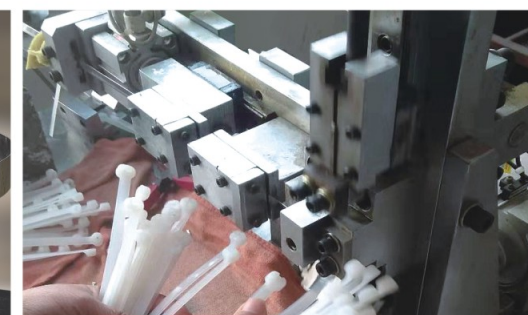

▶ 尼龙不锈钢嵌片扎带机
Nylon stainless steel embedded cable tie Machine

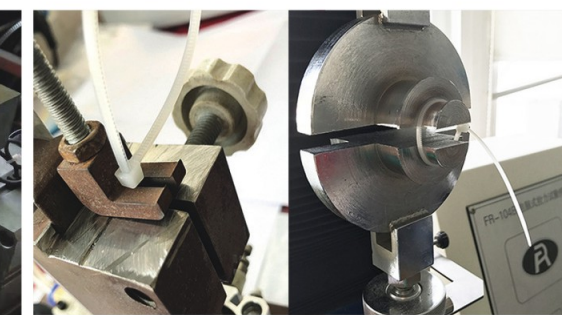

▶ 插入力测试、拉伸强度试验
Insertion force testing and Tensile strength testing



▶ 模具开发加工中心
Mould Development and Machining Center



▶ 线切割
Wire cut



▶ 线切割中心
Wire-electrode cutting instrument



▶ 电火花成型机
EDM Instrument



▶ 不锈钢喷塑机
Stainless steel spraying machine

精工细作，资质为证

Qualification Proves The Elaborate Manufacturing

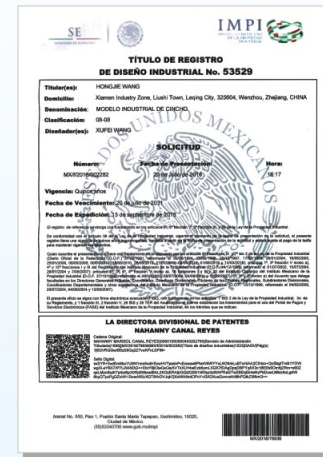
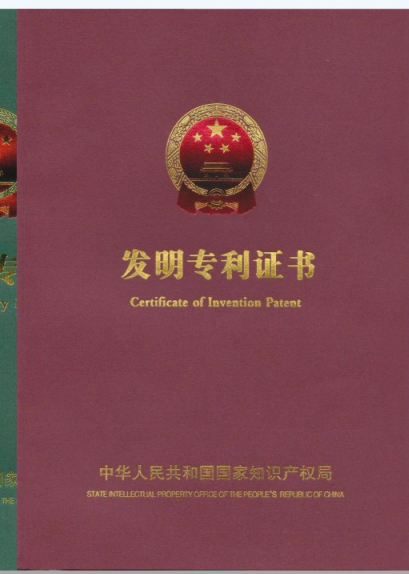
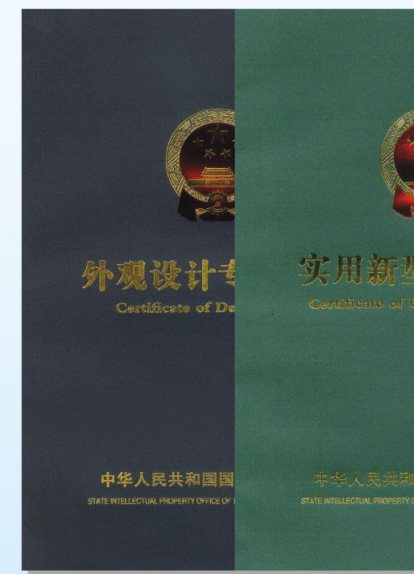
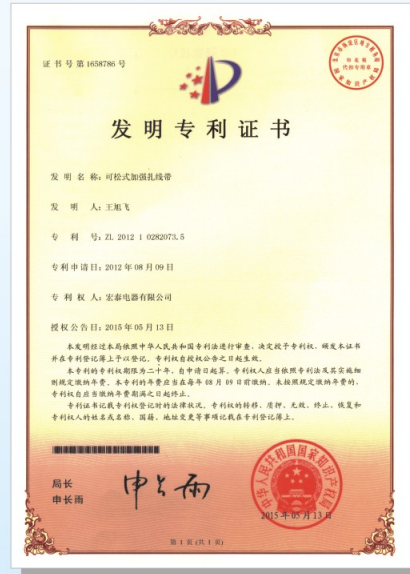
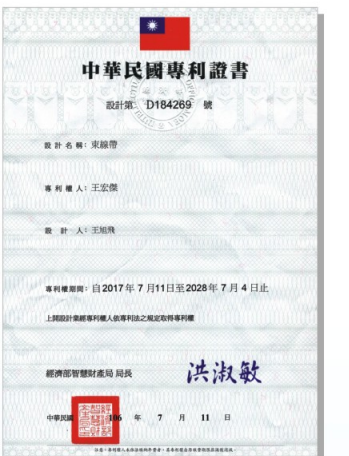
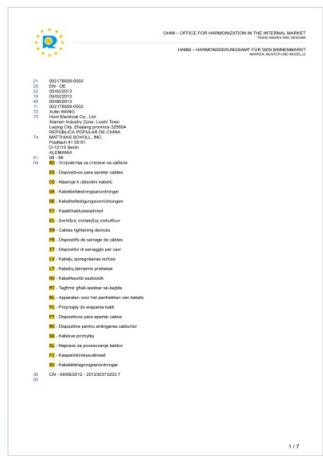
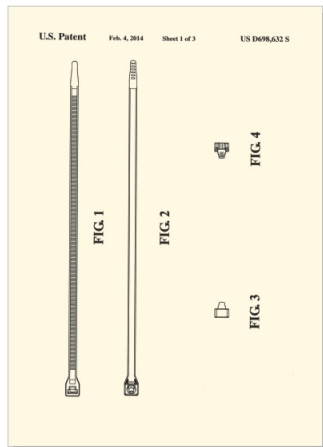
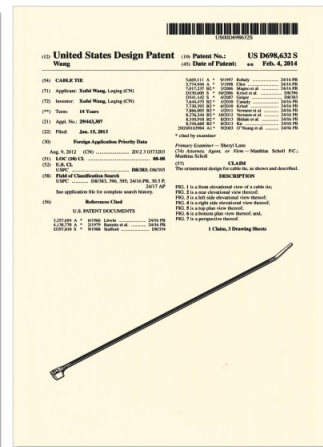
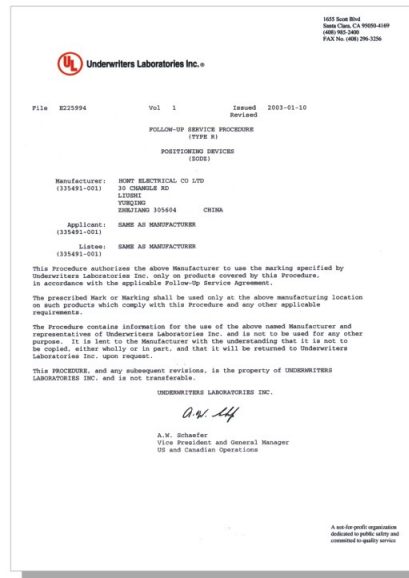

CONTENT 產品總覽

ONE nylon cable ties series 尼龍扎線帶系列

 Page01-02 尼龍扎線帶 NYLON CABLE TIE	 Page02 可退式扎線帶 RELEASABLE LASHING CABLE TIE	 Page03-06 拉力增加型自鎖式尼龍扎線帶 NYLON CABLE TIE	 Page06 標牌扎線帶 MARKER TIES	 Page07 分體式捆扎帶 SEPARATE TYPE CABLE TIE
 Page08 增強易穿金屬嵌片扎帶 ENHANCED EASY-TO-WEAR METAL INSERT CABLE TIE	 Page09 可鬆式扎帶 RELEASABLE CABLE TIE	 Page10 可鬆式扎線帶 RELEASABLE CABLE TIE	 Page10 橡膠扎帶 RUBBER CABLE TIE	 Page10 橡膠捆帶 RUBBER STRAPS
 Page11 自鎖雙面扎線帶 MARKER TIES	 Page11 硅膠綁帶 SILICONE CABLE TIE	 Page11 電源線束綫帶 CARD BAND	 Page12 硅膠萬能繩 REUSABLE RUBBER TWIST TIE	 Page12 固定頭式扎線帶 MOUNTABLE HEAD TIES
 Page13 標牌扎線帶 MARKER TIES	 Page13 盒子標牌扎線帶 BOX MARKER TIES	 Page13 固定頭式汽車扎線帶 MOUNTABLE CAR HEAD TIES	 Page14 固定頭式扎線帶 MOUNTABLE HEAD TIES	 Page14 圓頭式扎線帶 MOUNTABLE HEAD TIES
 Page14 插銷式扎線帶 PUSH MOUNT TIES	 Page15 插銷式扎線帶 PUSH MOUNT TIES	 Page15 插銷式扎線帶 PUSH MOUNT TIES	 Page15 插銷式扎線帶 PUSH MOUNT TIES	 Page16 雙扣式尼龍扎帶 DOUBLE LOCKING CABLE TIES
 Page16 雙頭扎線帶 DOUBLE HEAD CABLE TIE	 Page16 珠孔扎線帶 KNOT TIE(BALL TYPE)	 Page17 珠孔扎線帶 KNOT TIE(BALL TYPE)	 Page17 梯形扎線帶 TRAPEZOID TIE(BALL TYPE)	 Page 17 扣帶分體式扎線帶 FISSION STYLE CABLE TIE

TWO wire/cable strap stainless steel cable ties 電線捆綁帶/不銹鋼扎帶卡箱

 Page19 尼龍扎帶包裝款式A系列 PACKING OF SERIES A	 Page20-25 包裝款式B系列 PACKING OF SERIES B	 Page26 包裝款式B系列 PACKING OF SERIES B	 Page27-33 包裝款式C系列 PACKING OF SERIES C	 Page34-36 包裝款式D系列 PACKING OF SERIES D
 Page37 扎帶槍 TIE GUN	 Page39 黏扣帶(魔鬼氈/子母扣) HOOK & LOOP CABLE TIES(VELCRO)	 Page40 電綫綁帶 WIRE / CABLE STRAP SERIES	 Page41 一般粘扣帶 FASTENING TAPE	 Page41 小包裝系列 D.I.Y. PACKETS SERIES
 Page42 不銹鋼鎖鋼珠扎帶 STAINLESS STEEL LOCK STEEL BALL TIES	 Page42 萬能鋼帶箍 STAINLESS STEEL TIE (LADDER TYPE)	 Page43 不銹鋼捆綁帶 UNIVERSAL CLAMPING BAND	 Page44 不銹鋼噴塗扎帶-自鎖式 STAINLESS STEEL EPOXY COATED CABLE TIES	 Page46 固定頭尼龍不銹鋼嵌片扎帶 NYLON STAINLESS STEEL INLAY BLOCK TIES
 Page46 尼龍不銹鋼嵌片扎帶 NYLON STAINLESS STEEL INLAY BLOCK TIES	 Page47 HT-001-A萬能鋼帶箍 STAINLESS STEEL BAND CLAMPS	 Page47 標志帶 MARKER PLATE	 Page48 STAINLESS STEEL TIE(RELEASABLE TYPE WITH NYLON COATING)	 Page48 ZD帶式卡箍 ZD HOSE CLAMP
<h3>THREE nail cable clips series 鋼釘電線卡系列</h3>				
 Page50 圓型鋼釘綫卡系列 CIRCLE CABLE CLIPS	 Page50 鈎型鋼釘綫卡系列 HOOK CABLE CLIPS	 Page51 方型鋼釘綫卡系列 SQUARE CABLE CLIPS		
 Page51 雙釘式白扁電綫固定卡 DOUBLE NAIL FLAT CABLE CLIPS	 Page52 雙釘式白扁電綫固定卡 DOUBLE NAIL FLAT CABLE CLIPS	 Page53 鋼釘綫卡(包裝系列G) PACKING OF SERIES G	 Page54 鋼釘綫卡(包裝系列H) PACKING OF SERIES H	 Page54 K型固定夾 K TAPE CABLE CLAMPS

FOUR wiring accessories series
配线器材系列

 Page56 熱收縮套管 HEAT-SHRINKABLE TUBINGS	 Page57 HT扎帶固定座 CABLE TIE HOLDER	 Page58 卷式結束帶 SPIRAL WRAPPING BAND	 Page58 卷式纏繞帶 SPIRAL WRAPPING BAND	 Page58 粘式扎線固定座 CABLE TIE MOUNTS
 Page59 R型固定夾 RTAPE CABLE CLAMPS	 Page59 粘式扎線固定座 CABLE TIE MOUNTS	 Page59 扎線固定座 SADDLE TYPE TIE MOUNTS	 Page60 粘式扎線固定座 CABLE TIE MOUNTS	 Page60 鐵心扎絲帶 GALVANIZED PVC COATED WIRE
 Page61 塑料十字架 PLASTIC CROSS	 Page61 尼龍安全型壓線帽HT-($\phi 3-\phi 8$) NYLON CLOSE-END WIRING CONNECTOR HT-($\phi 3-\phi 8$)	 Page62 尼龍電纜固定頭 NYLON CABLE GLAND	 Page62 金屬電纜固定頭 METAL CABLE GLAND	 Page63 彈簧螺式接線頭HT-($\phi 3-\phi 8$) WIRE CONNECTORS HT-($\phi 3-\phi 8$)
 Page64 HT接線端子 TERMINAL BLOCKS	 Page65 W(U)系列接線端子 W(U) TYPE TERMINAL BLOCK (12 POLE)	 Page67 ECM型配線標志 ECM-TYPE WIRE MARKERS	 Page67 HT膨脹管 EXPAND NAILS	 Page68 絕緣配線槽 INSULATING DISTRIBUTING SLOT

FIVE electrical connector series
接線端子系列

 Page71 叉形預絕緣端子 FURCATE PRE-INSULATING TERMINAL	 Page72 圓形預絕緣端子 CIRCULAR PRE-INSULATING TERMINAL	 Page78 接線端子系列 Terminal Blocks Series	 Page78 接線端子系列 Terminal Blocks Series	 Page79 電動工具開關 Switches for electric tools
--------------------------------------------------------------------------------------------------------------------------------------------	----------------------------------------------------------------------------------------------------------------------------------------------	-----------------------------------------------------------------------------------------------------------------------------------	------------------------------------------------------------------------------------------------------------------------------------	------------------------------------------------------------------------------------------------------------------------------------------

ONE
nylon cable ties series
尼龍扎線帶系列



尼龍扎綫帶 NYLON CABLE TIE

材質：採用UL認可之尼龍66料制成，防火等級94V-2，耐酸、耐蝕、絕緣性良好，不易老化、承受力強。
 顏色：標準顏色為本色(白色)，另有抗外紫外線之黑色，特殊顏色歡迎訂做。
 備注：用戶如需要特殊溫度尼龍紮線帶，本公司可以提供定制。

Material: Nylon 66, 94V-2 certificated by UL. Heat-resisting, erosion control, insulate well and not apt to age.
Color: Natural (or white, standard color), UV black and other colors are available as requested.
Note: If the user needs special temperature nylon cable tie, we can supply.

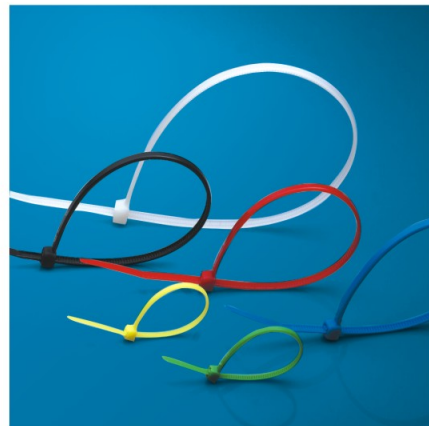

型號 ITEM NO.	長L		寬W MM	捆紮範圍 E BUNDLE DIAMETER MM	承受力 TENSILE STRENGTH	
	INCH	MM			LBS	KGS
HT-2.5×60	2.4"	60	2.5	2-11	18	8
HT-2.5×80	3.2"	80		2-16		
HT-2.5×100	4.0"	100		2-22		
HT-2.5×120	4.7"	120		2-30		
HT-2.5×150	6.0"	150		2-35		
HT-2.5×160	6.3"	160		2-40		
HT-2.5×200	8.0"	200		3-50		
HT-3.6×140	5.5"	140		3.6		
HT-3.6×150	6.0"	150	3-35			
HT-3.6×180	7.1"	180	3-42			
HT-3.6×200	8.0"	200	3-50			
HT-3.6×250	10"	250	3-65			
HT-3.6×280	11"	280	3-70			
HT-3.6×300	12"	300	3-80			
HT-3.6×370	14.6"	370	3-105			
HT-3.6×400	16"	400	3-105			
HT-4×100	4"	100	3.6	2-11	40	18
HT-4×350	13.7"	350		3-90		
HT-4.8×100	4"	100	4.8	3-22	50	22
HT-4.8×120	4.7"	120		3-30		
HT-4.8×160	6.3"	160		3-40		
HT-4.8×180	7.1"	180		3-42		
HT-4.8×190	7.5"	190		3-46		
HT-4.8×200	8.0"	200		3-50		
HT-4.8×250	10"	250		3-65		
HT-4.8×280	11"	280		3-70		
HT-4.8×300	12"	300		3-80		
HT-4.8×350	14"	350		3-90		
HT-4.8×360	14.2"	360		3-94		
HT-4.8×370	14.6"	370		3-98		
HT-4.8×380	15"	380		3-102		
HT-4.8×400	16"	400		3-105		
HT-4.8×430	16.9"	430		3-120		
HT-4.8×450	17.7"	450		3-130		
HT-4.8×500	19.7"	500		3-150		
HT-4.8×550	21.6"	550		3-162		
HT-4.8×920	36.2"	920		3-265		
HT-5×150	6"	150		4.8		
HT-5×610	24"	610	8-170			
HT-5×635	25"	635	3-189			
HT-7.2×150	6.0"	150	7.2	3-35	120	55
HT-7.2×200	8.0"	200		3-50		
HT-7.2×250	10"	250		4-65		
HT-7.2×280	11"	280		4-78		
HT-7.2×300	12"	300		4-80		
HT-7.2×350	14"	350		4-90		
HT-7.2×370	14.6"	370		4-98		
HT-7.2×380	15"	380		4-100		
HT-7.2×400	16"	400		4-105		
HT-7.2×450	18"	450		4-110		
HT-7.2×500	20"	500		4-150		
HT-7.2×530	20.9"	530		4-160		
HT-7.2×550	21.6"	550		4-165		
HT-7.2×1000	40"	1000		4-300		

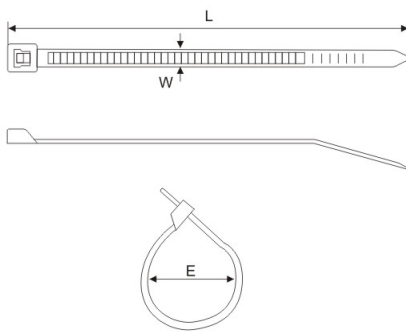

表續

型號 ITEM NO.	長L		寬W MM	捆紮範圍 E BUNDLE DIAMETER MM	承受力 TENSILE STRENGTH				
	INCH	MM			LBS	KGS			
HT-7.6×200	8"	200	7.6	3-50	120	55			
HT-7.6×250	10"	250		4-65					
HT-7.6×280	11"	280		4-78					
HT-7.6×300	12"	300		4-80					
HT-7.6×370	14.6"	370		4-98					
HT-7.6×380	15"	380		4-100					
HT-7.6×400	16"	400		4-105					
HT-7.6×450	18"	450		4-110					
HT-7.6×500	20"	500		4-150					
HT-7.6×530	20.9"	530		4-160					
HT-7.6×550	21.6"	550		4-165					
HT-7.6×750	29.5"	750		4-225					
HT-8.8×278	11"	278		8.8			8-75	175	79.4
HT-8.8×400	16"	400					8-105		
HT-8.8×450	18"	450	8-118						
HT-8.8×500	20"	500	8-150						
HT-8.8×550	21.6"	550	8-160						
HT-8.8×600	23.6"	600	8-170						
HT-8.8×650	25.6"	650	8-185						
HT-8.8×720	28.3"	720	10-195						
HT-8.8×800	31.5"	800	10-230						
HT-8.8×900	35.5"	900	10-265						
HT-8.8×1000	40"	1000	10-300						
HT-8.8×1100	43.3"	1100	10-335						
HT-8.8×1200	47.2"	1200	10-370						
HT-12×650	25.6"	650	12	14-185	250	114			
HT-12×900	35.5"	900		14-265					
HT-15×358	14"	358	15	15-93	350	160			

加厚型 Extra Tensile Strength Ties

HT-2.5×100	4.0"	100	2.5	2-22	28	13
HT-3.6×200	8.0"	200	3.6	3-50	60	28
HT-4.8×200	8.0"	200	4.8	3-50	80	36
HT-4.8×280	11"	280		3-70		
HT-4.8×300	12"	300		3-80		
HT-4.8×360	14.2"	360		3-94		
HT-4.8×370	14.6"	370	3-98			
HT-8.8×610	24.4"	610	8.8	8-170	230	104
HT-8.8×920	36.8"	920		10-265		
HT-8.8×1220	48.8"	1220		10-370		

可退式扎綫帶 RELEASABLE LASHING CABLE TIE

材質：UL合格之NYLON66(本色)，防火等級94V-2，不易老化。
Material: Nylon 66 certificated by UL.
Usage: These ties, which are easily assembled by hand or with pliers, remain securely locked until intentionally released by operating the finger catch.
 特點：可再鬆開，重複使用。

型號 ITEM.NO.	長L	寬W MM	(最大)捆紮範圍 MAX.BUNDLE DIA. MM	承受力 TENSILE STRENGTH		包裝 PACKING
				LBS	KGS	
HT-100	100	3.6	22	40	18	100PCS
HT-150	150	4.7	35	50	22	
HT-200	200	4.7	50	50	22	
HT-250	250	4.8	65	50	22	
HT-300	300	4.7	65	50	22	

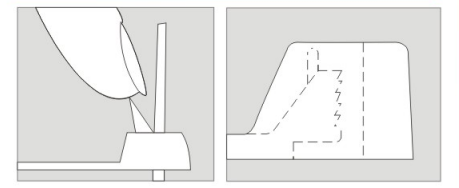
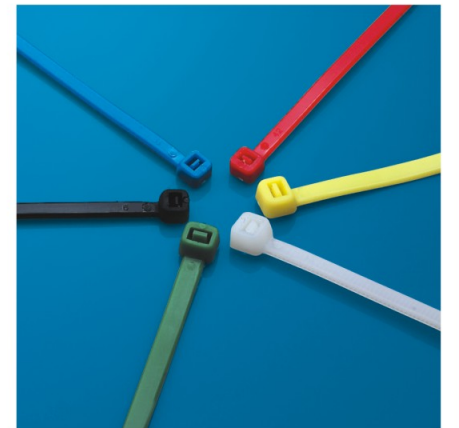
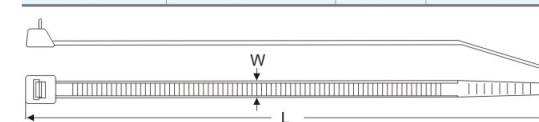

外扣型 內扣型

- 领先制造
- 高端品质
- 创新理念
- 专利技术
- 新品推荐

HONT 宏泰

- Manufacturing
- High quality
- Innovative idea
- Patent technology
- New Recommend



- 高端尼龙扎带；
- 拉力超过普通尼龙扎带 **25%**；
- 该产品比普通尼龙扎带更易于操作，穿插力小 **50%**；

- High quality cable ties;
- **25%** more stronger;
- Insert force reduce **50%**;

UL LISTED E225994 SGS CE TÜV RoHS PAHs Reach

HONT

拉力增加型自锁式尼龙扎线带 NYLON CABLE TIE

产品概述

一种易穿加固型尼龙线带，包括带体及连接在带体一端的锁扣头，锁扣头中设有通槽及弹性卡扣件，带体的背面密布有单嚮斜齿，弹性卡扣件的对应摩擦面上也相应设有单嚮斜齿配合，在锁扣头朝嚮带体的侧壁上设有缺口，并且在该嚮侧壁和带体的正面之间设有两个支撑坡块，两个支撑坡块分布在缺口的两边。本发明在锁扣头的侧壁设有缺口，增加了弹性变形量，使弹性卡扣件的弹性位移量也明显增加，穿带过程的摩擦阻力减少，操作轻松顺畅，穿带后的弹性卡扣力度也增加。并且，在缺口的两边设有两个支撑坡块：(1)在缺口底部设有卡头横嚮加强筋，起到加强卡头承受力的作用(2)锁扣头与带体的连接采用斜体连接方式，增加锁扣头与带体连接面积，加强锁扣头与带体的连接力。受力结构合理，支撑牢固，侧壁设有缺口也不会降低锁扣头的强度，弹性卡扣件受大力拉扯时也不易拉翻、滑脱或断裂，捆紮承载力可靠性高。

- 拉力超过普通自锁式尼龙扎带**25%**。
- 该产品比普通自锁式尼龙扎带更易于操作，穿插力小**50%**。
- 外形美观，穿插轻松效率高，能有效的减少装配时间和降低成本。

PRODUCT OVERVIEW

An enhanced cable tie easy to pass, include the tie body and buckle head, provide passing channel and elastic buckle part, unidirectional and close teeth designed on the back of tie body, the abrasive side of elastic buckle part is coordinated with the teeth, the side of buckle head facing on tie body provide a notch, and two support blocks are set between this side and front side of tie body, laid on two side of notch. This notch can increase the elastic distortion surplus, and the elastic displacement increase as well, the abrasion force of cable passing through decrease, operation is easy and smooth, the clamping force also increase. Furthermore, two support blocks on two sides of notch:

(1) horizontal stiffener assembled on the bottom of notch, to reinforce the withstand force of clamping head;
(2) The connection between buckle head and tie body is sloping jointed, this can increase the contact area between buckle head and tie body, enhance the connection force. The structure to withstand force is reasonable, support is reliable and solid, the notch also will not decrease the strength of buckle head, even if the elastic clamp part withstand large force, it will not turn over, slip out or be broken, the bundle force is highly reliable.

- The tension is **25%** more than ordinary.
- Self-locking type cable tie, and more easy to use, and small insert resistance **50%**.
- Aesthetic appearance, The easy operation can saving your time and cost, and improve efficiency.



新品 NEW 专利 PAT.



UL LISTED (POSITIONING DEVICE) 41XT E225994

新 产品上市受到用户高度好评!
Welcome in the Market!

专利产品、侵者必究
Patented product, Counterfeiting investigation



适用于捆绑电线、汽车线束、包装、农业、园艺、手工艺品捆扎、水道管、煤气管道等领域等。
Applicable to the binding wire, automotive wiring harness, packaging, agriculture, horticulture, handicrafts strapping, channel pipe, gas pipe, etc





新品 NEW 專利 PAT.

A型



新品 NEW 專利 PAT.

B型(自鎖可松式尼龙扎线带)



拉力增加型自鎖式尼龍扎綫帶 NYLON CABLE TIE

材質：採用UL認可之尼龍66料制成，防火等級94V-2，耐酸、耐蝕、絕緣性良好，不易老化、承受力強。
 顏色：標準顏色為本色(白色)，另有抗外紫外線之黑色，特殊顏色歡迎訂做。
 備註：用戶如需要特殊溫度尼龍紮線帶，本公司可以提供定制。

Material: Nylon 66, 94V-2 certified by UL. Heat-resisting, erosion control, insulate well and not apt to age.
Color: Natural (or white, standard color), UV black and other colors are available as requested.
Note: If the user needs special temperature nylon cable tie, we can supply.

型號 ITEM NO.	長L		寬W MM	捆紮範圍 E BUNDLE DIAMETER MM	承受力 TENSILE STRENGTH	
	INCH	MM			LBS	KGS
HTA-2.5×60	2.4"	60	2.5	2-11	22.5	10
HTA-2.5×80	3.2"	80		2-16		
HTA-2.5×100	4.0"	100		2-22		
HTA-2.5×120	4.7"	120		2-30		
HTA-2.5×150	6.0"	150		2-35		
HTA-2.5×160	6.3"	160		2-40		
HTA-2.5×200	8.0"	200		3-50		
HTA-3.6×110	4.3"	110		3.4		
HTA-3.6×140	5.5"	140	3-33			
HTA-3.6×150	6.0"	150	3-35			
HTA-3.6×180	7.1"	180	3-42			
HTA-3.6×200	8.0"	200	3-50			
HTA-3.6×250	10"	250	3-65			
HTA-3.6×280	11"	280	3-70			
HTA-3.6×300	12"	300	3-80			
HTA-3.6×370	14.6"	370	3-105			
HTA-4.8×120	4.7"	120	4.4		3-30	62.5
HTA-4.8×160	6.3"	160		3-40		
HTA-4.8×180	7.1"	180		3-42		
HTA-4.8×190	7.5"	190		3-46		
HTA-4.8×200	8.0"	200		3-50		
HTA-4.8×250	10"	250		3-65		
HTA-4.8×280	11"	280		3-70		
HTA-4.8×300	12"	300		3-80		
HTA-4.8×350	14"	350		3-90		
HTA-4.8×360	14.2"	360		3-94		
HTA-4.8×370	14.6"	370		3-98		
HTA-4.8×380	15"	380		3-102		
HTA-4.8×400	16"	400		3-105		
HTA-4.8×430	16.9"	430		3-120		
HTA-4.8×450	17.7"	450		3-130		
HTA-4.8×500	19.7"	500	3-150			
HTA-7.2×150	6.0"	150	7.2	3-35	150	69
HTA-7.2×200	8.0"	200		3-50		
HTA-7.2×250	10"	250		4-65		
HTA-7.2×280	11"	280		4-78		
HTA-7.2×300	12"	300		4-80		
HTA-7.2×350	14"	350		4-90		
HTA-7.2×370	14.6"	370		4-98		
HTA-7.2×380	15"	380		4-100		
HTA-7.2×400	16"	400		4-105		
HTA-7.2×450	18"	450		4-110		
HTA-7.2×500	20"	500		4-150		
HTA-7.2×530	20.9"	530		4-160		
HTA-7.2×550	21.6"	550		4-165		

拉力增加型自鎖式尼龍扎綫帶 NYLON CABLE TIE

表續

型號 ITEM NO.	長L		寬W MM	捆紮範圍 E BUNDLE DIAMETER MM	承受力 TENSILE STRENGTH	
	INCH	MM			LBS	KGS
HTA-9.0×400	16"	400	8.8	8-105	220	100
HTA-9.0×450	18"	450		8-118		
HTA-9.0×500	20"	500		8-150		
HTA-9.0×550	21.6"	550		8-160		
HTA-9.0×600	23.6"	600		8-170		
HTA-9.0×650	25.6"	650		8-185		
HTA-9.0×720	28.3"	720		10-195		
HTA-9.0×800	31.5"	800		10-230		
HTA-9.0×900	35.5"	900		10-265		
HTA-9.0×1000	40"	1000		10-300		
HTA-9.0×1100	43.3"	1100		10-335		
HTA-9.0×1200	47.2"	1200		10-370		
HTA-12×540	21.2"	540	12.4	8-155	310	140
HTA-12×650	25.6"	650		14-185		
HTA-12×900	35.5"	900		14-265		

加厚型 Increase Thickness Type

HTA-3.6×200	8.0"	200	3.6	3-50	60	28
HTA-4.8×200	8.0"	200	4.8	3-50	80	36
HTA-4.8×280	11"	280		3-70		
HTA-4.8×300	12"	300		3-80		
HTA-8.8×610	24.4"	610	8.8	8-170	230	104
HTA-8.8×920	36.8"	920		10-265		
HTA-8.8×1220	48.8"	1220		10-370		

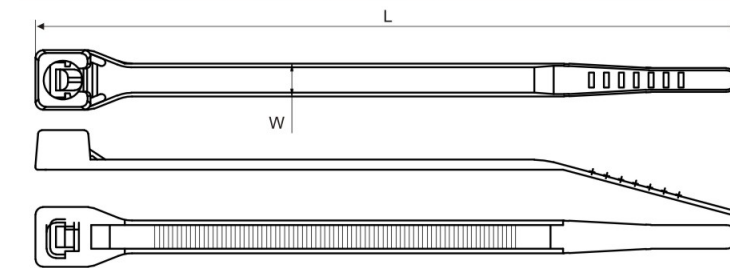

標牌扎綫帶 MARKER TIES

材質：採用UL認可尼龍66料制成，防火等級94V-2，耐酸蝕，不易老化。
 特點：紮帶前端設有空白標牌，可用筆在上面標誌記號。

Material: Nylon 66 94V-2 certified by UL. Acid control and not easy to age.
Usage: No blank tag at the entrance of cable tie, then write down the marker on the tag.

型號 ITEM NO.	長L		寬W MM	(最大捆紮範圍 MAX. BUNDLE DIA. MM)	承受力 TENSILE STRENGTH		標牌尺寸 MM
	INCH	MM			LBS	KGS	
HT-165MT	8.27"	210	4.6	3-40	50	22.0	

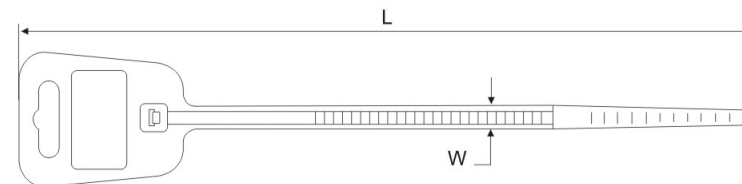

新品 NEW 專利 PAT.

UL LISTED (POSITIONING DEVICE) E225994



新品 NEW



分體式金屬嵌片捆扎帶 SEPARATE TYPE CABLE TIE

產品概述

一種分體式紮帶，包括獨立分體式的帶體和鎖扣頭，鎖扣頭中設有一個穿帶通槽，在鎖扣頭的下端還設有一個固定槽，在鎖扣頭穿帶通槽及固定槽嵌有用於固定的合金銅片，帶體的一端可以置於固定槽內和對應的卡扣件配合固定，帶體的另一端可以穿過穿帶通槽和對應的卡扣件單嚮鎖定配合。本產品的帶體和鎖扣頭互相分離，可以分別單獨生產，帶體可以成卷使用攜帶，使用時根據實際需要長度靈活取用，避免浪費帶體材料。並且，使用時帶體的一端置於固定槽內固定，只需用帶體另一端穿入鎖扣頭中捆紮操作，使用方式和傳統紮帶相同，容易上手，操作方便快速，穿帶阻力小，捆紮牢固。

材質：採用UL認可之聚甲醛(POM)材質制成，承受力強，耐高低溫。耐磨、耐沖擊，不易老化，使用溫度範圍-40℃~+85℃。

特點：分體設計，根據需求尺寸方便使用，節約材料環保。

PRODUCT OVERVIEW

One type of separated cable tie consists of an independent separated cable tie body and a lock catch head. Inside the lock catch head is a through-tie groove, and at the lower end of the lock catch head is a holddown groove. Alloy Copper sheets are embedded at the through-tie groove and the holddown groove of the lock catch head for the purpose of fixation. One end of the cable tie body can be placed in the holddown groove to match the corresponding fasteners for fixing, and the other end of the cable tie body can pass through the through-tie groove to lock and match the corresponding fasteners in one direction. The cable tie body and the lock catch head of the product are separated from each other and can be separately manufactured. The cable tie body can be used and carried in rolls and can be flexibly taken and used according to the actual required length during use, thereby avoiding material waste. Moreover, during use, one end of the cable tie body is fastened in the holddown groove, and the other end of the cable tie body is only required to be inserted into the lock catch head for bundling operation. The operation method is the same as that of the traditional cable tie, which features easy use, convenient and fast operation, small resistance to through-tie, and firm bundling.

Material:POM material is characterized by good low temperature resistance, strong endurance, high temperature resistance, wear resistance, impact resistance, and aging resistance. Temperature range of use is - 40 -+85 C.

Usage: Separate design, according to the size of demand. Save material and protect environment.

技術參數 Technical Parameter

型號 ITEM NO.	長L M	寬W MM	承受力 TENSILE STRENGTH		扣配數量 LOCK CATCH QTY	包裝尺寸 PACKING SIZE
			LBS	KGS		
HTS-7.6	15米/卷(可定制長度) 15m/Roll(Customized)	7.6	167	75	10-25個 (定制數量)	15m/Roll 21*21*1.5cm
HTS-8.8	0.55米/條 0.55m/pcs	8.8	178	80	10-25PCS/ Customized	10-50pcs
HTS-12.7	1.5米/條 1.5m/pcs	12.7	245	110		

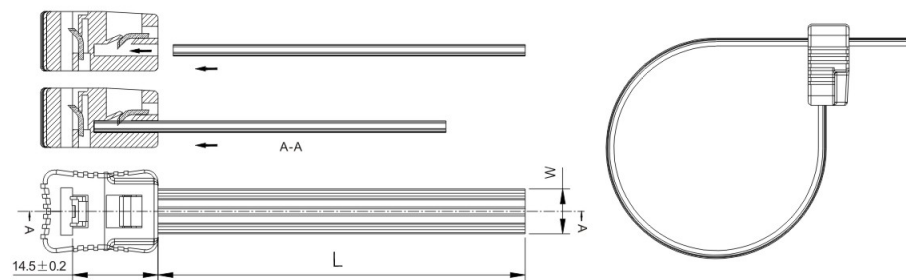

專利產品、侵者必究
Patented product, Counterfeiting investigation

增強易穿金屬嵌片扎帶 ENHANCED EASY-TO-WEAR METAL INSERT CABLE TIE

產品概述

本產品結構：一體連接在帶體一段的鎖扣頭，鎖扣頭中設有穿帶通槽，在穿帶通槽下方的鎖扣頭內還設有限位空間，中間折彎的金屬卡扣於限位空間內間隙可擺動式布置，金屬卡扣的上端露出於穿帶通槽中，帶體的自由端可以穿帶通槽和金屬卡扣件單嚮鎖定配合。

金屬卡扣件在鎖扣頭中間隙擺動，帶體穿入時金屬卡扣件被觸碰而擺動下壓，不會阻礙帶體的穿入位移，穿帶阻力小，使用方便。如果帶體要逆嚮拉出，金屬卡扣件的端部被拉動上擺，鉤觸帶體表面單嚮鎖定，鎖定强度高，大力拉扯也不會斷裂托送，牢固可靠。且鎖扣頭和金屬卡扣件分別獨立制造再裝配，生產方便。

材質：合金銅片，帶體採用UL認可之尼龍66料制成，防火等級94V-2，耐酸、耐蝕、絕緣性良好，不易老化、承受力強。

特點：拉力大，穿插力小，使用便捷！

- 拉力超過普通尼龍不銹鋼嵌片扎帶**25%**。
- 該產品比普通尼龍不銹鋼嵌片扎帶更易于操作，穿插力小**50%**。
- 外形美觀，穿插輕鬆效率**高**，能有效的減少裝配時間和降低**成本**。

PRODUCT OVERVIEW

Structure of the product: one end is connected to the lock catch head of a section of the cable tie body. Inside the lock catch head is a through-tie groove, and inside the lock catch head under the through-tie groove is a limiting space. Metal fasteners bent in the middle are arranged in a swing motion in the gap of the limiting space. The upper end of the metal fastener is exposed in the through-tie groove. The free end of the cable tie body can be unidirectionally locked and matched by the through-tie groove and the metal fastener. The metal fastener swings in the gap between the lock catch heads, and the metal fasteners are touched and swayed down when the cable tie body is inserted, which will not hinder the insertion and shift of the cable tie body. The resistance to insertion of cable tie is small, and the use is convenient. If the cable tie body is to be pulled out in the reverse direction, the end of the metal fastener will be pulled and swayed upward. The hook contact of the cable tie body surface is locked in one direction. The locking strength is high, and the product will not break even in case of strong pulling. It is firm and reliable. Moreover, the lock catch head and the metal fastener are separately manufactured and reassembled, so manufacturing is convenient.

Material: Alloy copper sheet, Nylon 66, 94V-2 certificated by UL. Heat-resisting, erosion control, insulate well and not apt to age.

Usage: Large pulling force, small penetration force, easy to use!

- **The tension is 25% more than ordinary.**
- **Stainless steel chips cable ties, and more easy to use, and small insert resistance 50%.**
- **Aesthetic appearance, The easy operation can saving your time and cost, and improve efficiency.**

技術參數 Technical Parameter

型號 ITEM NO.	長L		寬W MM	捆紮範圍 E BUNDLE DIAMETER MM	承受力 TENSILE STRENGTH	
	INCH	MM			LBS	KGS
HTEA-7.6×220	8.6"	220	7.6	8.5-57.2	175	75
HTEA-7.6×300	11.8"	300		8.5-82.8		
HTEA-7.6×350	14"	350		8.5-90.0		
HTEA-7.6×370	14.5"	370		8.5-103.5		
HTEA-7.6×460	18.0"	460		8.5-130.5		
HTEA-7.6×620	24.4"	620		8.5-181.5		

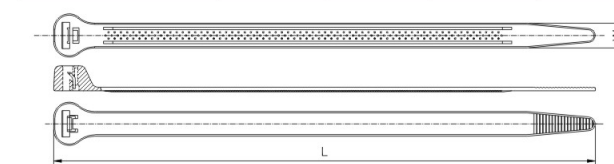

專利產品、侵者必究
Patented product, Counterfeiting investigation





可鬆末端約束式扎帶 RELEASABLE CABLE TIE

產品概述

產品結構：帶體及連接在帶體一端的鎖扣頭，鎖扣頭中設有通槽及彈性卡扣件，該彈性卡扣件朝嚮鎖扣頭外側、也即背離帶體的方嚮設有延伸部形成按壓鍵；在鎖扣頭和帶體之間設有過渡片連接，在過渡片的表面設有橋梁狀的約束件，且約束件的通過空隙和帶體的規格相適應，形成穿帶後再約束結構。過渡片的中間設有通孔，約束件位於過渡片和帶體的連接處旁邊。

使用中，將按壓鍵下壓時，彈性卡扣件和帶體表面脫離配合接觸，帶體可自由雙嚮拉動，靈活方便的回退調節捆紮松緊程度，還可以將紮線帶完全解開，不影響重複使用，大大減少了浪費。按壓鍵的方嚮背離帶體，外圍操作的空間大，更加順暢。並且約束件可以束縛帶體的多餘部分不影響後續操作。

材質：採用UL認可之尼龍66料制成，防火等級94V-2，耐酸、耐蝕、絕緣性良好。

特點：一般電源線之綁紮，可再鬆開重複使用。末端約束，頭部可鬆開。

PRODUCT OVERVIEW

Structure of the product: includes a cable tie body and a lock catch head connected to one end of the cable tie body. Inside the lock catch head is a through-tie groove and an elastic fastener which faces the outer side of the lock catch head. In other words, a part is extended in the direction deviating from the cable tie body to form the button of Press. A transition piece connection is provided between the lock catch head and the cable tie body. A bridge-like constraint piece is arranged on the surface of the transition piece. The through-gap of the constraint piece matches the specification of the cable tie body, forming a re-constrain structure after the tie is past through. A through hole is arranged in the middle of the transition piece, and the constraint piece is located beside the joint of the transition piece and the cable tie body. In use, when the button of Press is held down, the elastic fastener and the surface of the cable tie body are disengaged, matched and contacted. The cable tie body can be freely pulled in two directions and flexibly and conveniently retracted to adjust the tightness of the binding. Also, the cable tie can be completely unwound, significantly reducing waste without affecting its reuse. The direction of the button of Press deviates from the cable tie body. Peripheral operation has a large space and is smoother. Furthermore, the constraint piece can restrain the excess portion of the cable tie body without affecting subsequent operations.

Material: Nylon 66 certificated by UL.

Usage: Beaded design keeps wires from shifting or slipping, end under control, Haed part can be released.

技術參數 Technical Parameter

型號 ITEM NO.	長L		寬W MM	(最大)捆紮範圍 MAX.BUNDLE DIA. MM	承受力 TENSILE STRENGTH		包裝 PACKING
	INCH	MM			LBS	KGS	
HTR-4.8×180	7.5"	180	4.8	45	40	18	100PCS
HTR-4.8×220	8.6"	220	4.8	55			
HTR-4.8×250	10"	250	4.8	65	50	22	100PCS
HTR-7.6×180	7.5"	180	7.6	45			
HTR-7.6×220	8.6"	220	7.6	55			
HTR-7.6×250	10"	250	7.6	65			

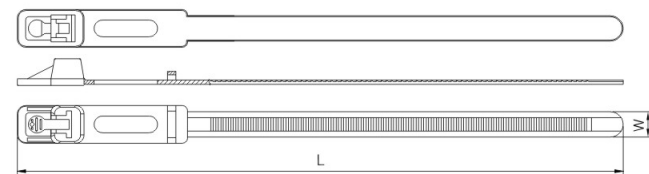

專利產品、侵者必究
Patented product, Counterfeiting investigation

可鬆式扎綫帶 RELEASABLE CABLE TIE

材質：UL合格之NYLON 66，防火等級94V-2，不易老化。

特點：可再鬆開，重複使用。

Material: Nylon 66 certificated by UL.

Usage: These ties, which are easily assembled by hand or with pliers, remain securely locked until intentionally released by operating the finger catch.

型號 ITEM NO.	長L		寬W MM	(最大)捆紮範圍 MAX.BUNDLE DIA. MM	承受力 TENSILE STRENGTH		包裝 PACKING
	INCH	MM			LBS	KGS	
HT-150RT	6"	150	7.6	35	50	22	100PCS
HT-200RT-A	8"	200		50	75	34	
HT-200RT-B	8"	200		50			
HT-250RT	10"	250		65	50	22	
HT-300RT	12"	300		80			
HT-400RT	16"	400		100			
HT-200RTA	8"	200	4.8	50	40	18	100PCS

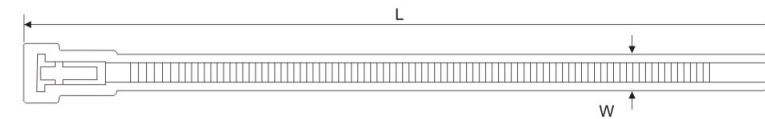

橡膠扎帶 RUBBER CABLE TIE

材質：UL認可之橡膠料制成。

特點：環保橡皮筋，防老化橡皮筋，防老化橡膠圈。

Material: UL Approved Rubber Material Made

Usage: Environmental rubber band, anti-aging rubber band.

型號 ITEM NO.	長L		寬W MM	(最大)捆紮範圍 MAX.BUNDLE DIA. MM	承受力 TENSILE STRENGTH		包裝 PACKING
	INCH	MM			LBS	KGS	
HTRC-10.5	12.4"	315	10.5	3-80	2.2	5	100

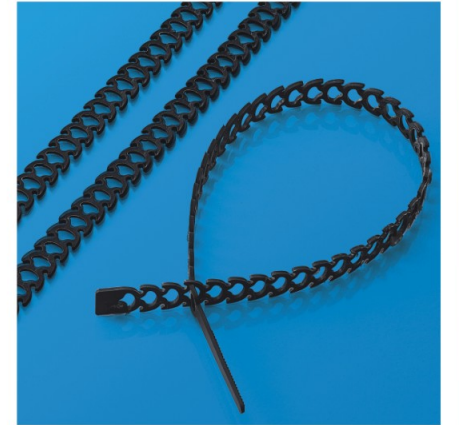
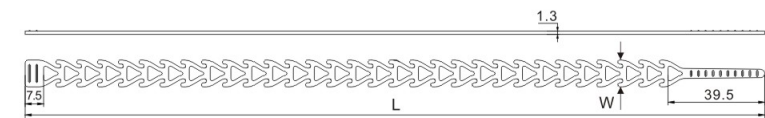

橡膠捆帶 RUBBER STRAPS

材質：UL認可之橡膠料制成。

特點：環保橡皮筋，防老化橡皮筋，防老化橡膠圈。

Material: UL Approved Rubber Material Made

Usage: Environmental rubber band, anti-aging rubber band.

型號 ITEM NO.	直徑ΦMM	包裝 PACKING
HTR-40	40	500

應用示意圖 APPLICATION SCENARIO

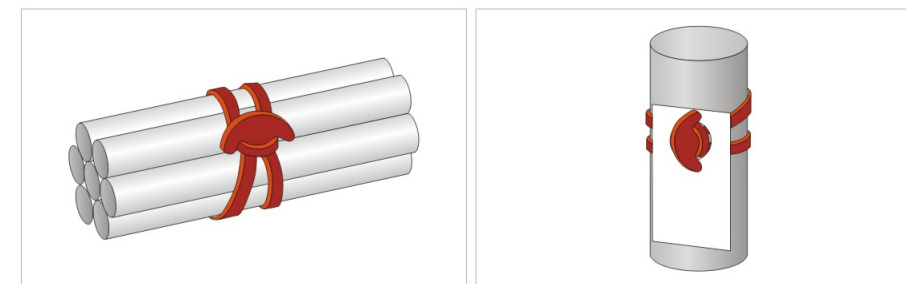

新品
NEW



自鎖式雙面扎綫帶 SELF LOCKING DOUBLE WIRE BINDING BELT

材質：採用UL認可之尼龍66料制成，防火等級94V-2，耐酸、耐蝕、絕緣性良好，不易老化、承受力強。
 特點：雙面齒設計，拉力比普通紮帶增加20%以上。
 專利產品：外觀專利號(ZL2015 3 0205610.0),實用專利號(ZL2015 2 0426493.5)
 Material: Nylon 66, 94V-2 certificated by UL. Heat-resisting, erosion control, insulate well and not apt to age.
 Characteristic: Double face gear design, Pulling force increased by more than 20% than ordinary tie.
 Patent product: Appearance patent number (2015 3 0205610.0), Utility patent number (2015 2 0426493.5)

型號 ITEM NO.	長L		寬W MM	(最大)捆紮範圍 MAX.BUNDLE DIA. MM	承受力 TENSILE STRENGTH		包裝 PACKING
	INCH	MM			LBS	KGS	
HTS-3.5×200	8"	200	3.5	50	50	22.0	
HTS-4.6×200	8"	200	4.6	50	75	34.0	
HTS-4.6×280	11.2"	280	4.6	70	75	34.0	
HTS-4.6×360	14.4"	360	4.6	94	75	34.0	

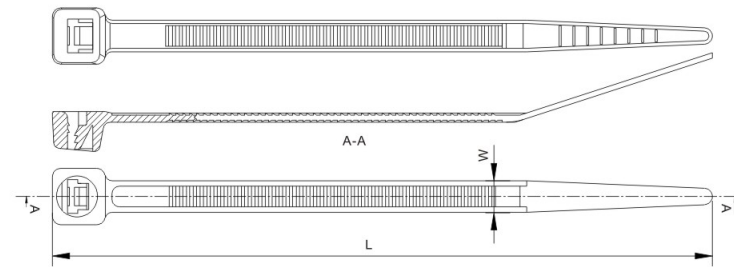

新品 NEW 專利 PAT.



硅膠綁帶 SILICONE CABLE TIE

材質：UL認可之環保矽膠制成。
 特點：矽膠綁帶安全環保，使用快捷，抗撕裂，耐磨，抗疲勞性彎曲，防水抗震效果好。
 專利產品、優者必究
 Material: UL Approved Made of environmentally friendly silica gel.
 Usage: Safety and environmental protection, easy to bend, Waterproof and anti-seismic effect is good.
 Patented product, Counterfeiting investigation

型號 ITEM NO.	長L		寬W MM	(最大)捆紮範圍 MAX.BUNDLE DIA. MM	承受力 TENSILE STRENGTH		包裝 PACKING
	INCH	MM			LBS	KGS	
HTG-175	6.8"	175	-	5-45	-	-	-

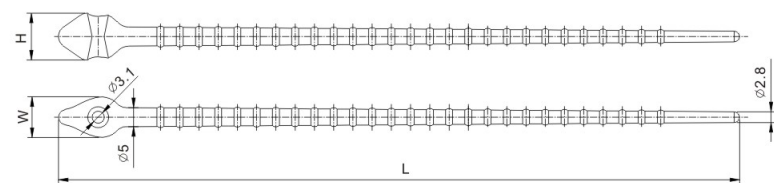

應用示意圖 APPLICATION SCENARIO

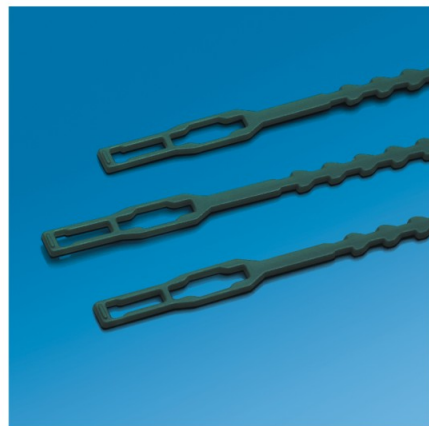
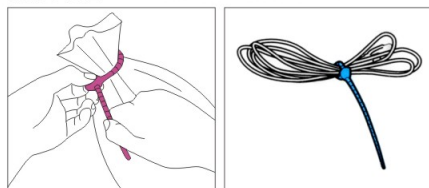

電源綫束綫帶 CARD BAND

材質：PE
 用途：捆綁電線作包裝用，可重複使用。
 顏色：墨綠
 Material: Polyethylene PE
 Usage: Wrap electrical cords for shipping and packaging. Inexpensive and Releasable.
 Color: Dark green

型號 ITEM NO.	長L		寬W MM	(最大)捆紮範圍 MAX.BUNDLE DIA. MM	承受力 TENSILE STRENGTH		包裝 PACKING
	INCH	MM			LBS	KGS	
HT-150CB	6"	150	=	39	30	14	100PCS

硅膠萬能繩 REUSABLE RUBBER TWIST TIE

材質：UL認可之環保矽膠制成。
 特點：該產品具有良好的柔韌性，而且又有耐酸，城腐蝕，抗氧化，不生銹、環保、反復使用等功能。
 Material: UL Approved Made of environmentally friendly silica gel.
 Usage: Safety and environmental protection, easy to bend, Waterproof and anti-seismic effect is good.

型號 ITEM NO.	長L		寬W MM	(最大)捆紮範圍 MAX.BUNDLE DIA. MM	承受力 TENSILE STRENGTH		包裝 PACKING
	INCH	MM			LBS	KGS	
HT-4.0×75	3.0"	75	4.0	-	-	-	100
HT-4.0×100	4.0"	100					
HT-4.0×152	6.0"	152					
HT-4.0×200	8.0"	200					
HT-4.0×305	12.0"	305					
HT-5.0×75	3.0"	75	5.0	-	-	-	100
HT-5.0×100	4.0"	100					
HT-5.0×152	6.0"	152					
HT-5.0×200	8.0"	200					
HT-5.0×305	12.0"	305					
HT-5.0×380	15.0"	380	6.5	-	-	-	100
HT-6.5×305	12.0"	305					
HT-6.5×457	18.0"	457					
HT-6.5×610	24.0"	610					
HT-6.5×810	32.0"	810					

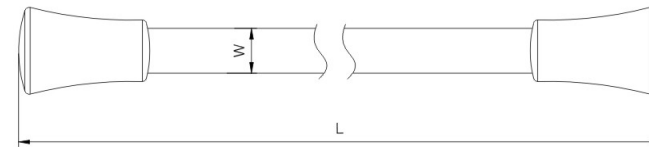

固定頭式扎綫帶 MOUNTABLE HEAD TIES

材質：UL認可之尼龍66料制成。
 特點：紮帶捆紮電線後，將整束電線用螺絲固定於基板上。
 Material: Nylon 66 certificated by UL.
 Usage: after bundling wires, fix them on plate with screw.

型號 ITEM NO.	長L		寬W MM	(最大)捆紮範圍 MAX.BUNDLE DIA. MM	承受力 TENSILE STRENGTH		包裝 PACKING
	INCH	MM			LBS	KGS	
HT-100MH	4"	100	2.5	22	18	8	100PCS
HT-100MA	4"	100	3.6	22	40	18	
HT-150MH	6"	150	3.6	32			
HT-200MH-A	8"	200	4.8	42	50	22	
HT-200MH-B	8"	200	4.8	42	80	36	
HT-300MH	12"	300	7.2	80	120	55	
HT-200MA	8"	200	7.2	50	120	55	
HT-350MA	14"	350	7.2	90	120	55	
HT-380MA	14"	380	7.2	90	120	55	

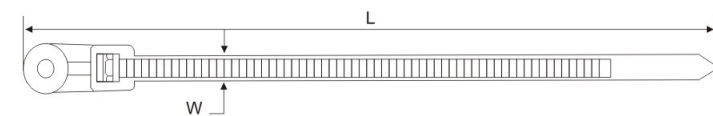

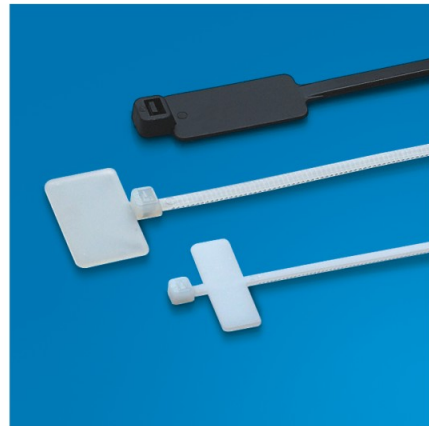

標牌扎綫帶 MARKER TIES

材質: 採用UL認可尼龍66料制成, 防火等級94V-2, 耐酸蝕, 不易老化。
特點: 紮帶前端設有空白標牌, 可用筆在上面標誌記號。
Material: Nylon 66 94V-2 certified by UL. Acidcontrol and not easy to age.
Usage: No blank tag at the entrance of cable tie, then write down the marker on the tag.

型號 ITEM.NO.	長L		寬W MM	(最大捆紮範圍 MAX.BUNDLE DIA. MM)	承受力 TENSILE STRENGTH		標牌尺寸 MM
	INCH	MM			LBS	KGS	
HT-100MT	4"	100	2.5	22	18	8.0	25×8
HT-200MT	8"	200	3.6/4.6	50	50	22.0	25×13
HT-210MT	8.27"	210	3.0	-	-	10.0	25×15

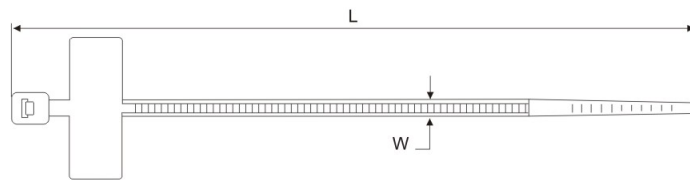

盒子標牌扎綫帶 BOX MARKER TIES

材質: 採用UL認可尼龍66料制成, 防火等級94V-2, 耐酸蝕, 不易老化。
特點: 紮帶前端設有空白標牌, 可用筆在上面標誌記號。
Material: Nylon 66 94V-2 certified by UL. Acidcontrol and not easy to age.
Usage: No blank tag at the entrance of cable tie, then write down the marker on the tag.

型號 ITEM.NO.	長L		寬W MM	(最大捆紮範圍 MAX.BUNDLE DIA. MM)	承受力 TENSILE STRENGTH		標牌尺寸 MM
	INCH	MM			LBS	KGS	
HT-180MT	7.2"	180	5.0	55	50	22.0	34.0
HT-240MT	9.6"	240	5.0	74			

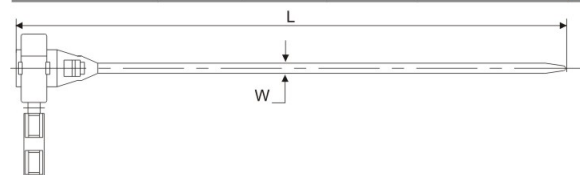

新品 NEW



固定頭式汽車扎綫帶 MOUNTABLE CAR HEAD TIES

材質: UL認可之尼龍66料制成。
特點: 紮帶捆紮電線後, 將整束電線用螺絲固定於基板上。
Material: Nylon 66 certified by UL.
Usage: after bundling wires, fix them on plate with screw.

型號 ITEM NO	長L		寬W MM	捆紮範圍 E BUNDLE DIAMETER MM	承受力 TENSILE STRENGTH	
	INCH	MM			LBS	KGS
HT-165	6.6"	165	4.8	3~35	50	22

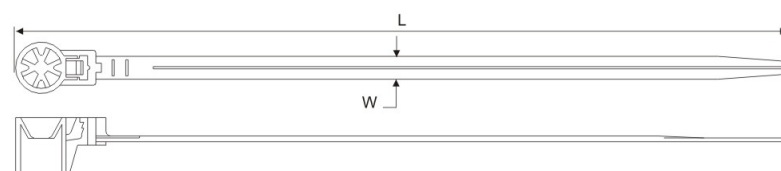

固定頭式扎綫帶 MOUNTABLE HEAD TIES

材質: UL認可之尼龍66料制成。
特點: 紮帶捆紮電線後, 將整束電線用螺絲固定於基板上。
Material: Nylon 66 certified by UL.
Usage: after bundling wires, fix them on plate with screw.

型號 ITEM NO	長L		寬W MM	捆紮範圍 E BUNDLE DIAMETER MM	承受力 TENSILE STRENGTH	
	INCH	MM			LBS	KGS
HT-165A	6.6"	165	7.4	5~35	120	55



新品 NEW

圓頭式扎綫帶 MOUNTABLE HEAD TIES

材質: UL認可之尼龍66料制成。
特點: 紮帶捆紮電線後, 將整束電線用螺絲固定於基板上。
Material: Nylon 66 certified by UL.
Usage: after bundling wires, fix them on plate with screw.

型號 ITEM NO	長L		寬W MM	捆紮範圍 E BUNDLE DIAMETER MM	承受力 TENSILE STRENGTH	
	INCH	MM			LBS	KGS
HT-300	12"	300	6.0	5~86	100	48
HT-300A	12"	300	7.6	5~86	120	55
HT-380A	15.2"	380	7.6	5~110		

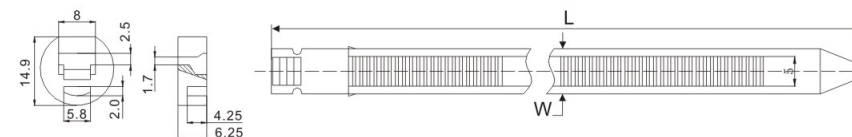

新品 NEW

插銷式扎綫帶 PUSH MOUNT TIES

材質: 採用UL認可尼龍66料制成, 防火等級94V-2, 耐酸, 耐蝕, 絕緣性良好, 不易老化, 承受力強。
使用方法: 先將機板鑽孔, 然後把紮帶插入孔內, 再將電線紮緊即可。
Material: Nylon 66, 94V-2, agreed by UL. Acid and corrode resisting, insulate, last long and not apt to age.
Usage: insert tie to the hole of table and tighten it.

型號 ITEM.NO.	長L		寬W MM	(最大捆紮範圍 MAX.BUNDLE DIA. MM)	承受力 TENSILE STRENGTH		孔徑(Φ) HOLE DIA		板機厚度 PANEL THICKNESS		包裝 PACKING
	INCH	MM			LBS	KGS	INCH	MM	INCH	MM	
HT-200PTA	8.0"	200	4.8	50	50	22	-	-	-	-	100PCS

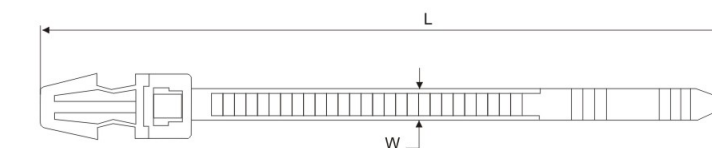

新品 NEW



新品 NEW

插銷式扎綫帶 PUSH MOUNT TIES

材質: 採用UL認可尼龍66料制成, 防火等級94V-2, 耐酸, 耐蝕, 絕緣性良好、不易老化、承受力強。
使用方法: 先將機板擱孔, 然後把紮帶插入孔內, 再將電線紮緊即可。
Material: Nylon 66, 94V-2, agreed by UL. Acid and corrode resisting, insulate, last long and not apt to age.
Usage: insert tie to the hole of table and tighten it.

型號 ITEM.NO.	長L		寬W MM	(最大)捆紮範圍 MAX.BUNDLE DIA. MM	承受力 TENSILE STRENGTH		孔徑(Φ) HOLE DIA		板機厚度 PANEL THICKNESS		包裝 PACKING
	INCH	MM			LBS	KGS	INCH	MM	INCH	MM	
HT-190PT	7.6"	190	4.8	3~42	50	22	0.236	6.0	0.118	3.0	100PCS

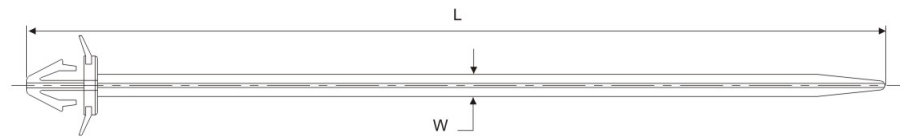

插銷式扎綫帶 PUSH MOUNT TIES

材質: 採用UL認可尼龍66料制成, 防火等級94V-2, 耐酸, 耐蝕, 絕緣性良好、不易老化、承受力強。
使用方法: 先將機板擱孔, 然後把紮帶插入孔內, 再將電線紮緊即可。
Material: Nylon 66, 94V-2, agreed by UL. Acid and corrode resisting, insulate, last long and not apt to age.
Usage: insert tie to the hole of table and tighten it.

型號 ITEM.NO.	長L		寬W MM	(最大)捆紮範圍 MAX.BUNDLE DIA. MM	承受力 TENSILE STRENGTH		孔徑(Φ) HOLE DIA		板機厚度 PANEL THICKNESS		包裝 PACKING
	INCH	MM			LBS	KGS	INCH	MM	INCH	MM	
HT-100PT	4"	100	2.5	25	18	8.0	0.189	4.5	0.094	2.4	100PCS
HT-150PT	6"	155	3.6	35	40	18	0.181	4.6	0.091	2.3	
HT-200PT	8"	200	4.8	50	50	22	0.236	6.0	0.118	3.0	

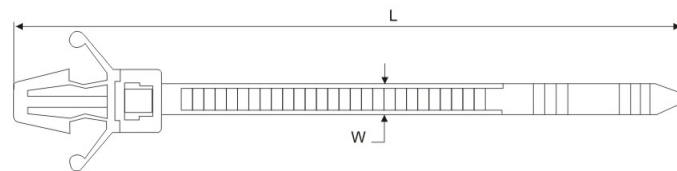

應用示意圖 APPLICATION SCENARIO

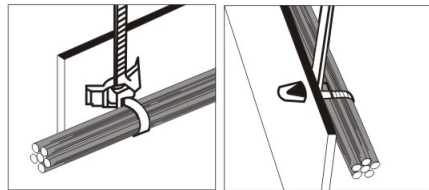

插銷式扎綫帶 PUSH MOUNT TIES

材質: 採用UL認可尼龍66料制成, 防火等級94V-2, 耐酸, 耐蝕, 絕緣性良好、不易老化、承受力強。
使用方法: 先將機板擱孔, 然後把紮帶插入孔內, 再將電線紮緊即可。
Material: Nylon 66, 94V-2, agreed by UL. Acid and corrode resisting, insulate, last long and not apt to age.
Usage: insert tie to the hole of table and tighten it.

型號 ITEM.NO.	長L		寬W MM	(最大)捆紮範圍 MAX.BUNDLE DIA. MM	承受力 TENSILE STRENGTH		孔徑(Φ) HOLE DIA		板機厚度 PANEL THICKNESS		包裝 PACKING
	INCH	MM			LBS	KGS	INCH	MM	INCH	MM	
HT-145PT	5.8"	145	7.8	5~31	120	55	-	-	-	-	100PCS

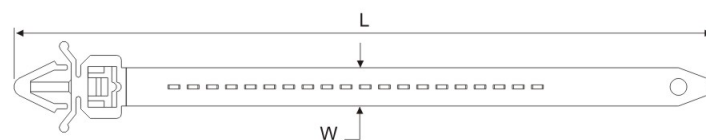

新品 NEW

雙扣式尼龍扎帶 DOUBLE LOCKING CABLE TIES

材質: 採用UL認可尼龍66(黑色)料制成, 防火等級94V-2, 耐酸蝕, 不易老化。
特點: 雙鎖式設計、承受力特強。
Material: Nylon 66 94V-2 certificated by UL. Acid-control and not easy to age.
Usage: double locking, strong supporting capacity

編號 ITEM.NO.	長L		寬W MM	捆紮範圍 E BUNDLE DIAMETER MM	拉力 TENSILE STRENGTH		備註 NOTE
	INCH	MM			PA12(KGS)	PA66(KGS)	
HT-114DL	4.5"	114	6.0	8-28	18	35	單扣 Solo lock
HT-175DL	6.8"	175	6.0	8-40	18	35	
HT-180DL	7"	180	9.0	15-45	25	40	
HT-180DDL	7"	180	9.0	15-45	25	40	雙扣 Double lock
HT-260DL	10 1/4"	260	9.0	30-66	40	50	
HT-350DL	13 5/8"	350	9.0	30-90	40	50	

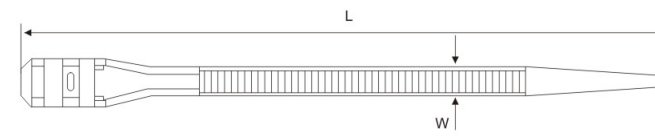

雙頭扎綫帶 DOUBLE HEAD CABLE TIE

材質: UL合格之NYLON 66 (本色), 防火等級94V-2。
Material: Nylon 12 94V-2 certificated by UL.

編號 ITEM.NO.	長L		寬W MM	D1		D2		承受力 TENSILE STRENGTH		包裝 PACKING
	INCH	MM		MAX.	MIN.	MAX.	MIN.	IBS	KGS	
RDCV-225	8 7/8"	225	4.8	59	2.5	52	2.0	50	22	100PCS
RDCV-300	11 7/8"	300	4.8	83	2.5	76	2.0	50	22	
RDCV-370	14 9/16"	370	4.8	105	2.5	98	2.0	50	22	

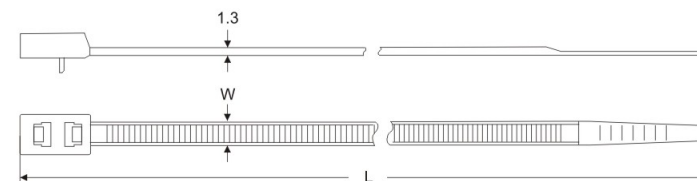

珠孔扎綫帶 KNOT TIE(BALL TYPE)

材質: UL合格之NYLON 66(本色), 防火等級94V-2。
Material: Nylon 66 certificated by UL.
用途: 一般電源線之綁紮, 可再鬆開重複使用。
Usage: Beaded design keeps wires from shifting or slipping.

型號 ITEM NO.	長L		寬W MM	(最大)捆紮範圍 MAX.BUNDLE DIA. MM	承受力 TENSILE STRENGTH		包裝 PACKING
	INCH	MM			LBS	KGS	
HT-100KTA	4"	100	-	25	18	8	100PCS
HT-150KTA	6"	150	-	39	18	8	
HT-200KTA	8"	200	-	50	18	8	

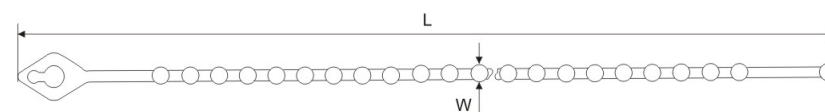

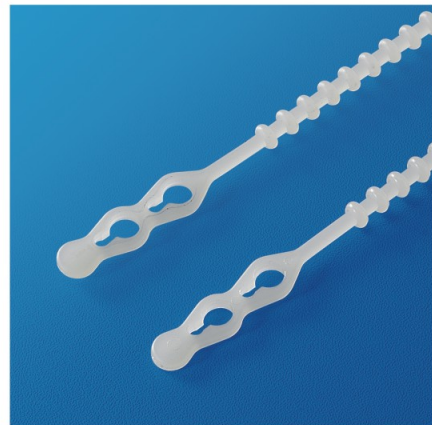

珠孔扎綫帶 KNOT TIE(BALL TYPE)

材質: UL合格之NYLON 66(本色), 防火等級94V-2。 **Material:** Nylon 66 certificated by UL.
用途: 一般電源線之綁紮,可再松開重複使用。 **Usage:** Beaded design keeps wires from shifting or slipping.

型號 ITEM NO.	長L		寬W MM	(最大) 捆紮範圍 MAX.BUNDLE DIA. MM	承受力 TENSILE STRENGTH		包裝 PACKING
	INCH	MM			LBS	KGS	
HT-235KTA	9.2"	235	5	5-65	55	29	100PCS
HT-310KTA	12.2"	310	5	5-80	55	29	

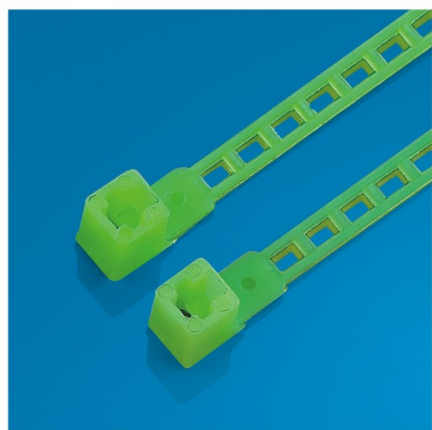
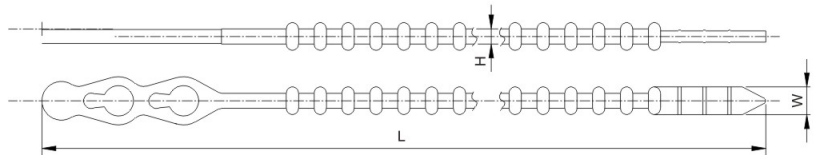

梯形扎綫帶 TRAPEZOID TIE(BALL TYPE)

材質: UL合格之NYLON 66(本色), 防火等級94V-2。 **Material:** Nylon 66 certificated by UL.
用途: 一般電源線之綁紮,可再松開重複使用。 **Usage:** Beaded design keeps wires from shifting or slipping.

型號 ITEM NO.	長L		寬W MM	(最大) 捆紮範圍 MAX.BUNDLE DIA. MM	承受力 TENSILE STRENGTH		包裝 PACKING
	INCH	MM			LBS	KGS	
HT-300	12"	300	3.6	5-88	18	8	100PCS

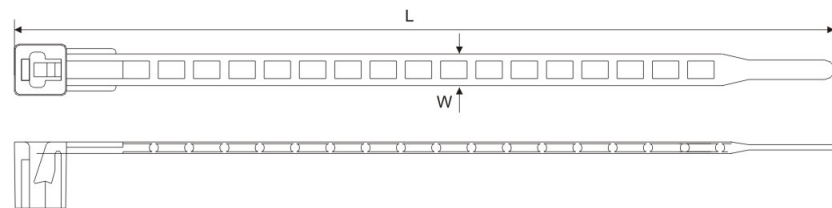

新品
NEW



扣帶分體式扎綫帶

FISSION STYLE CABLE TIE (DIVISION BETWEEN CABLE TIE LOCK AND CABLE TIE BODY)

規格 Specification
7.6×1500MM

尼龍產品使用須知

- 1.為了發揮最佳使用性能, 尼龍產品都必須經過最適當的吸水處理, 吸水作業完成後, 請務必用塑膠袋密封, 以免產品乾燥。
- 2.若產品存放於環境不良的地方時(如冬季期間等), 使用前先放置於室溫(20°C)2小時後再使用。

NYLON PRODUCTS USAGE NOTICE

1. In order to play the best performance, nylon products must get through suitable water-absorbing processing. Then they should be sealed in polybags to avoid getting dry.
2. If nylon products are put in unsuitable surrounding temperature such as in winter, they should be kept in indoor (temperature 20°C), and use it 2 hours later.

ONE nylon tape packaging series 尼龍扎帶包裝系列



尼龍扎帶包裝款式A系列 PACKING OF SERIES A

規格 MM	外箱尺寸 CM	數量 BAG	內盒尺寸 CM	數量 BAG	毛/淨重 KG
2.5×60	47×42×32	600	40×22×31	300	12/10
2.5×80	47×44×32	600	42×22×31	300	13/11
2.5×100	51×48×30	500	46×24×29	250	15/13
2.5×120	51×48×30	500	46×24×29	250	20/18
2.5×150	47×34×30	250	32×22×29	125	12/11
2.5×160	47×34×30	250	32×22×29	125	13/11
2.5×200	47×44×32	250	42×22×31	125	16/14
3.6×140	47×42×32	250	40×22×31	125	17/15
3.6×150	51×48×30	250	46×24×29	125	18/16
3.6×200	51×48×30	200	46×24×29	100	18/16
3.6×250	51×47×32	200	52×22×31	100	22/20
3.6×280	47×44×32	150	42×22×31	75	22/20
3.6×300	51×48×30	150	46×24×29	75	23/21
3.6×370	47×44×32	100	42×22×31	50	19/17
4.8×120	51×48×30	200	46×24×29	100	18/16
4.8×160	43×42×32	150	40×22×31	75	17/15
4.8×180	47×42×32	150	42×22×31	75	17/15
4.8×200	51×48×30	150	46×24×29	75	18/16
4.8×250	43×42×32	100	40×20×31	50	18/16
4.8×280	47×42×32	100	40×22×31	50	21/19
4.8×300	47×42×32	100	40×22×31	50	22/20
4.8×350	51×48×30	100	46×24×29	50	24/22
4.8×380	54×47×30	100	52×22×29	50	26/24
4.8×400	54×47×32	100	52×22×31	50	28/26
4.8×430	54×34×25	50	52×16×24	25	15/13
4.8×450	56×34×25	50	54×16×24	25	16/14
4.8×500	60×34×25	50	58×16×24	25	17/15
7.2×150	47×44×32	100	42×22×31	50	15/13
7.2×200	47×34×30	50	32×22×29	25	14/12
7.2×250	43×42×32	50	40×22×31	25	16/14
7.2×300	47×42×32	50	40×22×31	25	17/15
7.2×350	51×48×30	50	46×24×29	25	21/19
7.2×380	54×47×30	50	52×22×29	25	22/20
7.2×400	54×47×32	50	52×22×31	25	23/21
7.2×450	56×34×25	25	54×16×24	12/13	13/11
7.2×500	62×32×25	25	60×15×24	12/13	14/13
7.2×550	65×32×25	25	63×15×31	12/13	15/13
9.0×400	54×49×32	30	52×23×31	15	23/21
9.0×450	58×42×25	20	56×20×24	10	19/17
9.0×500	60×40×25	20	58×19×24	10	20/18
9.0×550	65×40×25	20	63×19×24	10	21/19
9.0×600	70×34×15	10	68×16×14	5	13/11
9.0×650	75×34×15	10	73×15×14	5	14/12
9.0×700	80×34×15	10	78×16×14	5	15/13
9.0×750	85×34×15	10	83×16×14	5	16/14
9.0×800	90×34×15	10	88×16×14	5	17/15
9.0×900	100×34×15	10	98×16×14	5	19/17
9.0×1000	110×34×15	10	108×16×14	5	20/18
9.0×1100	120×34×15	10	118×16×14	5	22/20
9.0×1200	130×34×15	10	128×16×14	5	24/22
12×650	75×34×24	10	73×16×23	5	17/15
12×900	100×34×25	10	98×16×24	5	24/22



包裝款式B系列 PACKING OF SERIES B

1000PCS PACKING

ITEM NO.	B1-1000	
DETAIL	2.5×100MM 4"	400PCS
	3.6×150MM 6"	300PCS
	3.6×200MM 8"	200PCS
	3.6×300MM 12"	100PCS
MEAS	54×44×34CM	
QTY	20SETS/CTN (10SETS/INNER BOX) 6900 SETS/20' CONTAINER	
G.W/N.W	16/14KG	
KEEVE	DIA:Φ10CM,HEIGHT:31CM	



300PCS PACKING

ITEM NO.	B2-300	
DETAIL	2.5×100MM 4"	200PCS
	3.6×200MM 8"	100PCS
MEAS	40×40×48CM	
QTY	50SETS/CTN (25SETS/INNER BOX) 17300 SETS/20' CONTAINER	
G.W/N.W	12/10KG	
KEEVE	DIA:Φ7.5CM,HEIGHT:21CM	



200PCS PACKING

ITEM NO.	B3-200	
DETAIL	2.5×100MM 4"	100PCS
	2.5×150MM 6"	50PCS
	3.6×200MM 8"	50PCS
MEAS	42×31×48CM	
QTY	70SETS/CTN (35SETS/INNER BOX) 31300 SETS/20' CONTAINER	
G.W/N.W	10/8KG	
KEEVE	DIA:Φ5.5CM,HEIGHT:21CM	



包裝款式B系列 PACKING OF SERIES B

1200PCS PACKING

ITEM NO.	B4-1200		
DETAIL	2.5×100MM	4"	500PCS
	3.6×150MM	6"	200PCS
	4.8×200MM	8"	400PCS
	4.8×300MM	12"	100PCS
MEAS	62×37×32.5CM		
QTY	15SETS/CTN 5200 SETS/20'CONTAINER		
G.W/N.W	18/16KG		
KEEVE	DIA:Φ12CM,HEIGHT:31CM		



1000+1PCS PACKING

ITEM NO.	B5-1000+1		
DETAIL	2.5×100MM	4"	500PCS
	2.5×150MM	6"	100PCS
	3.6×200MM	8"	300PCS
	3.6×300MM	12"	100PCS
	TG-6 TIE GUN		1PC
MEAS	62×37×32.5CM		
QTY	15SETS/CTN 5200 SETS/20'CONTAINER		
G.W/N.W	14/12KG		
KEEVE	DIA:Φ12CM,HEIGHT:31CM		



850PCS PACKING

ITEM NO.	B6-850		
DETAIL	2.5×100MM	4"	500PCS
	3.6×200MM	8"	300PCS
	4.8×300MM	12"	50PCS
MEAS	54×44×34CM		
QTY	20SETS/CTN (10SETS/INNER BOX) 6900 SETS/20'CONTAINER		
G.W/N.W	14/12KG		
KEEVE	DIA:Φ10CM,HEIGHT:31CM		



包裝款式B系列 PACKING OF SERIES B

1000PCS PACKING

ITEM NO.	B7-1000		
DETAIL	2.5×100MM	4"	500PCS
	3.6×150MM	6"	200PCS
	3.6×200MM	8"	300PCS
MEAS	58×48×27.5CM		
QTY	20SETS/CTN (10SETS/INNER BOX) 6700 SETS/20'CONTAINER		
G.W/N.W	18/16KG		
KEEVE	DIA:Φ11CM,HEIGHT:25CM		



1000+1PCS PACKING

ITEM NO.	B8-800+1		
DETAIL	2.5×100MM	4"	300PCS
	2.5×150MM	6"	200PCS
	3.6×180MM	7.1"	200PCS
	4.8×200MM	8"	100PCS
	CABLE CUTTER		1PC
MEAS	54×44×48CM		
QTY	40SETS/CTN (20SETS/INNER BOX) 9800 SETS/20'CONTAINER		
G.W/N.W	17/15KG		
KEEVE	DIA:Φ10CM,HEIGHT:21CM		



650PCS PACKING

ITEM NO.	B9-650		
DETAIL	2.5×100MM	4"	300PCS
	3.6×150MM	6"	200PCS
	4.8×200MM	8"	150PCS
MEAS	54×44×48CM		
QTY	40SETS/CTN (20SETS/INNER BOX) 9800 SETS/20'CONTAINER		
G.W/N.W	19/17KG		
KEEVE	DIA:Φ10CM,HEIGHT:21CM		



包裝款式B系列 PACKING OF SERIES B

500PCS PACKING

ITEM NO.	B10-500		
DETAIL	2.5×100MM	4"	300PCS
	2.5×200MM	8"	200PCS
MEAS	40×40×48CM		
QTY	50SETS/CTN (25SETS/INNER BOX) 17300 SETS/20'CONTAINER		
G.W/N.W	15/13KG		
KEEVE	DIA:Φ7.5CM,HEIGHT:21CM		



250PCS PACKING

ITEM NO.	B11-250		
DETAIL	2.5×100MM	4"	100PCS
	2.5×150MM	6"	100PCS
	3.6×200MM	8"	50PCS
MEAS	42×31×48CM		
QTY	70SETS/CTN (35SETS/INNER BOX) 31300 SETS/20'CONTAINER		
G.W/N.W	11/10KG		
KEEVE	DIA:Φ5.5CM,HEIGHT:21CM		



800PCS PACKING

ITEM NO.	B12-800		
DETAIL	2.5×100MM	4"	300PCS
	2.5×120MM	4.7"	200PCS
	2.5×150MM	6"	200PCS
	2.5×200MM	8"	100PCS
MEAS	51×50×30CM		
QTY	24SETS/CTN (12SETS/INNER BOX) 8700 SETS/20'CONTAINER		
G.W/N.W	13/12KG		



包裝款式B系列 PACKING OF SERIES B

500PCS PACKING

ITEM NO.	B13-500		
DETAIL	2.5×100MM	4"	200PCS
	3.6×140MM	5.5"	100PCS
	3.6×150MM	6"	100PCS
	3.6×180MM	7"	50PCS
	4.8×200MM	8"	50PCS
MEAS	51×31×30CM		
QTY	24SET/CTN 13920 SETS/20'CONTAINER		
G.W/N.W	14/12KG		
KEEVE	L×W×H: 25.5×16×3.5cm		



600PCS PACKING

ITEM NO.	B14-600		
DETAIL	2.5×100MM	4"	200PCS
	3.6×150MM	6"	100PCS
	3.6×180MM	7"	100PCS
	3.6×200MM	8"	100PCS
	4.8×230MM	9"	100PCS
	CABLE CUTTER		1PC
MEAS	54×30×39CM		
QTY	16SET/CTN 6880 SETS/20'CONTAINER		
G.W/N.W	13/11KG		
KEEVE	L×W×H: 25.5×25×4.3cm		



500PCS PACKING

ITEM NO.	B15-500		
DETAIL	2.5×100MM	4"	500PCS
MEAS	40×40×37CM		
QTY	50 SETS/CTN (25 SETS/INNER BOX) 8700 SETS/20'CONTAINER		
G.W/N.W	15/13KG		



包裝款式B系列 PACKING OF SERIES B

250PCS PACKING

ITEM NO.	B16-250		
DETAIL	2.5×100MM	4"	100PCS
	2.5×150MM	6"	100PCS
	3.6×200MM	8"	50PCS
MEAS	44×42×29CM		
QTY	36SETS/CTN (18SETS/INNER BOX) 17300 SETS/20' CONTAINER		
G.W/N.W	11/9KG		
KEEVE	DIA:Φ6.8CM,HEIGHT:26.5CM		



500PCS PACKING

ITEM NO.	B17-500		
DETAIL	2.5×100MM	4"	300PCS
	3.6×200MM	8"	200PCS
MEAS	54×44×48CM		
QTY	40SETS/CTN (20SETS/INNER BOX) 31300 SETS/20' CONTAINER		
G.W/N.W	15/13KG		
KEEVE	DIA:Φ10CM,HEIGHT:21CM		



600PCS PACKING

ITEM NO.	B18-600		
DETAIL	2.5×100MM	4"	300PCS
	3.6×200MM	8"	200PCS
	4.8×250MM	10"	100PCS
MEAS	58×48×27.5CM		
QTY	20SETS/CTN (10SETS/INNER BOX) 8700 SETS/20' CONTAINER		
G.W/N.W	13/11KG		
KEEVE	DIA:Φ11CM,HEIGHT:25CM		



包裝款式B系列 PACKING OF SERIES B

200PCS PACKING

ITEM NO.	B19-200		
DETAIL	2.5×100MM	4"	100PCS
	3.6×200MM	8"	100PCS
MEAS	38×29×24CM		
QTY	20SETS/CTN (10SETS/INNER BOX)		
G.W/N.W	5/4KG		



200PCS PACKING

ITEM NO.	B20-200		
DETAIL	2.5×100MM	4"	100PCS
	4.8×200MM	8"	100PCS
MEAS	38×29×24CM		
QTY	20SETS/CTN (10SETS/INNER BOX)		
G.W/N.W	6/5KG		



粘式扎線固定座(包裝系列B) PACKING OF SERIES B

ITEM NO.	B21-80	
DETAIL	HT-25	PCS
MEAS	40×40CM	
QTY	20SETS/CTN	
G.W/N.W	14/12KG	



包裝款式C系列 PACKING OF SERIES C

200PCS PACKING

ITEM NO.	C1-200		
DETAIL	2.5×100MM	4"	200PCS
MEAS	61×37×36CM		
QTY	100SETS/CTN (25SETS/INNER BOX)		
G.W/N.W	11/9KG		



75PCS PACKING

ITEM NO.	C2-75		
DETAIL	2.5×100MM	4"	25PCS
	4.8×120MM	4.7"	25PCS
	4.8×200MM	8"	25PCS
MEAS	61×37×36CM		
QTY	100SETS/CTN (25SETS/INNER BOX)		
G.W/N.W	12/10KG		



75PCS PACKING

ITEM NO.	C3-75		
DETAIL	2.5×100MM	4"	25PCS
	2.5×120MM	4.7"	25PCS
	3.6×200MM	8"	25PCS
MEAS	56×33×36CM		
QTY	80SETS/CTN (20SETS/INNER BOX)		
G.W/N.W	7/5KG		



包裝款式C系列 PACKING OF SERIES C

75PCS PACKING

ITEM NO.	C4-75		
DETAIL	2.5×100MM	4"	25PCS
	4.8×120MM	4.7"	25PCS
	4.8×185MM	7.3"	25PCS
MEAS	56×33×36CM		
QTY	80SETS/CTN (20SETS/INNER BOX)		
G.W/N.W	13/11KG		



粘式扎綫固定座(包裝系列G) PACKING OF SERIES G

ITEM NO.	C5-140		
DETAIL	2.5×100MM	4"	100PCS
	HT-1/4 R		10PCS
	HT-20		10PCS
	8mm		20PCS
MEAS	44×27×26CM		
QTY	40SETS/CTN (20SETS/INNER BOX)		
G.W/N.W	4/3KG		



粘式扎綫固定座(包裝系列C) PACKING OF SERIES C

ITEM NO.	C-6		
DETAIL	HT-25		6PCS
MEAS	38×26×44CM		
QTY	200SETS/CTN (10SETS/INNER BOX)		
G.W/N.W	6/5KG		



包裝款式C系列 PACKING OF SERIES C

75PCS PACKING

ITEM NO.	C7-75		
DETAIL	2.5×100MM	4"	25PCS
	2.5×150MM	6"	25PCS
	3.6×200MM	8"	25PCS
MEAS	80×45×70CM		
QTY	120SETS/CTN (30SETS/INNER BOX)		
G.W/N.W	14/12KG		



包裝款式C系列 PACKING OF SERIES C

150PCS PACKING

ITEM NO.	C10-150		
DETAIL	2.5×100MM	4"	50PCS
	4.8×120MM	4.7"	50PCS
	4.8×200MM	8"	50PCS
MEAS	51×38×30CM		
QTY	100SETS/CTN (50SETS/INNER BOX)		
G.W/N.W	10/9KG		



30PCS PACKING

ITEM NO.	C8-30		
DETAIL	3.6×150MM	6"	30PCS
MEAS	50×45×40CM		
QTY	400SETS/CTN (100SETS/INNER BOX)		
G.W/N.W	15/13KG		



150PCS PACKING

ITEM NO.	C11-150		
DETAIL	2.5×100MM	4"	50PCS
	2.5×120MM	4.7"	50PCS
	2.5×150MM	6"	50PCS
MEAS	52×44×25CM		
QTY	60SETS/CTN (30SETS/INNER BOX)		
G.W/N.W	7/5KG		



150PCS PACKING

ITEM NO.	C9-150		
DETAIL	2.5×100MM	4"	50PCS
	2.5×150MM	6"	50PCS
	3.6×200MM	8"	50PCS
MEAS	51×38×30CM		
QTY	100SETS/CTN (20SETS/INNER BOX)		
G.W/N.W	9/7KG		



250PCS PACKING

ITEM NO.	C12-250		
DETAIL	2.5×150MM	6"	250PCS
MEAS	52×44×25CM		
QTY	60SETS/CTN (30SETS/INNER BOX)		
G.W/N.W	9/7KG		



包裝款式C系列 PACKING OF SERIES C

100PCS PACKING

ITEM NO.	C13-100		
DETAIL	2.5×100MM	4"	80PCS
	3.6×200MM	8"	20PCS
	CABLE CUTTER		1PC
MEAS	48×29×36CM		
QTY	20SETS/CTN (10SETS/INNER BOX)		
G.W/N.W	8/6KG		



100PCS PACKING

ITEM NO.	C14-1000		
DETAIL	2.5×100MM	4"	300PCS
	2.5×120MM	4.7"	300PCS
	3.6×150MM	6"	150PCS
	3.6×180MM	7"	100PCS
	3.6×200MM	8"	80PCS
	4.8×250MM	10"	50PCS
	7.2×300MM	12"	20PCS
MEAS	57×46×52CM		
G.W/N.W	12/10KG		



1350PCS PACKING

ITEM NO.	C15-1350		
DETAIL	2.5×100MM	4"	800PCS
	3.6×150MM	6"	150PCS
	4.8×200MM	4.7"	350PCS
	4.8×280MM	11"	50PCS
MEAS	57×38×25CM		
G.W/N.W	12/10KG		



包裝款式C系列 PACKING OF SERIES C

50PCS PACKING

ITEM NO.	C16-50	
DETAIL	3.6×150MM	6"
MEAS	50×45×40CM	
QTY	400SETS/CTN (100SETS/INNER BOX)	
G.W/N.W	15/13KG	



40PCS PACKING

ITEM NO.	C17-40		
DETAIL	2.5×100MM	4"	20PCS
	2.5×150MM	6"	10PCS
	3.6×180MM	8"	10PCS
MEAS	57×43×38CM		
QTY	144SETS/CTN (24SETS/INNER BOX)		
G.W/N.W	8/6KG		



40PCS PACKING

ITEM NO.	C18-40		
DETAIL	2.5×100MM	4"	20PCS
	2.5×150MM	6"	15PCS
	2.5×200MM	8"	5PCS
MEAS	57×43×38CM		
QTY	144SETS/CTN (24SETS/INNER BOX)		
G.W/N.W	8/6KG		





包裝款式C系列 PACKING OF SERIES C

60PCS PACKING

ITEM NO.	C19-40		
DETAIL	2.5×100MM	4"	20PCS
	2.5×150MM	6"	20PCS
	3.5×200MM	8"	20PCS
MEAS	56×33×46CM		
QTY	96SETS/CTN (48SETS/INNER BOX)		
G.W/N.W	9/7KG		



40PCS PACKING

ITEM NO.	C20-200		
DETAIL	2.5×150MM	6"	200PCS
MEAS	54×36×35CM		
QTY	60SETS/CTN		
G.W/N.W	6/5KG		



60PCS PACKING

ITEM NO.	C21-160		
DETAIL	2.5×100MM	4"	100PCS
	6MM		20PCS
	8MM		40PCS
MEAS	53×28.5×36.5CM		
QTY	50SETS/CTN (25SETS/INNER BOX)		
G.W/N.W	7/6KG		



60PCS PACKING

ITEM NO.	C22-60		
DETAIL	2.5×150MM	6"	60PCS
MEAS	50×45×40CM		
QTY	400SETS/CTN		
G.W/N.W	13/11KG		

包裝款式D系列 PACKING OF SERIES D

75PCS PACKING

ITEM NO.	D1-75		
DETAIL	2.5×100MM	4"	25PCS
	4.8×120MM	4.7"	25PCS
	4.8×200MM	8"	25PCS
MEAS	54×34×32CM		
QTY	200SETS/CTN (100SETS/INNER BOX)		
G.W/N.W	14/12KG		



150PCS PACKING

ITEM NO.	D2-150		
DETAIL	2.5×100MM	4"	50PCS
	4.8×120MM	4.7"	50PCS
	4.8×200MM	8"	50PCS
MEAS	34×34×32CM		
QTY	100SETS/CTN (50SETS/INNER BOX)		
G.W/N.W	17/15KG		



75PCS PACKING

ITEM NO.	D3-75		
DETAIL	3.6×150MM	6"	75PCS
MEAS	54×30×32CM		
QTY	200SETS/CTN (100SETS/INNER BOX)		
G.W/N.W	13/11KG		



60PCS PACKING

ITEM NO.	D4-60		
DETAIL	2.5×100MM	4"	20PCS
	2.5×150MM	6"	20PCS
	2.5×200MM	8"	20PCS
MEAS	54×30×30CM		
QTY	240SETS/CTN (120SETS/INNER BOX)		
G.W/N.W	9/7KG		



包裝款式D系列 PACKING OF SERIES D

200PCS PACKING

ITEM NO.	D6-200	
DETAIL	2.5×100MM 4"	200PCS
MEAS	40×30×30CM	
QTY	120SETS/CTN (60SETS/INNER BOX)	
G.W/N.W	9/7KG	



150PCS PACKING

ITEM NO.	D7-150	
DETAIL	2.5×100MM 4"	50PCS
	4.8×120MM 4.7"	50PCS
	4.8×200MM 8"	50PCS
MEAS	54×34×32CM	
QTY	100SETS/CTN (50SETS/INNER BOX)	
G.W/N.W	17/15KG	



60PCS PACKING

ITEM NO.	D8-60	
DETAIL	2.5×100MM 4"	30PCS
	2.5×150MM 6"	15PCS
	2.5×200MM 8"	15PCS
MEAS	45×30×30CM	
QTY	240SETS/CTN (120SETS/INNER BOX)	
G.W/N.W	8/7KG	



包裝款式D系列 PACKING OF SERIES D

40PCS PACKING

ITEM NO.	D10-40	
DETAIL	3.6×150MM 6"	20PCS
	4.8×200MM 8"	20PCS
MEAS	40×35×35CM	
QTY	200SETS/CTN (100SETS/INNER BOX)	
G.W/N.W	10/8KG	



60PCS PACKING

ITEM NO.	D11-60	
DETAIL	2.5×100MM 4"	20PCS
	2.5×150MM 6"	20PCS
	3.6×200MM 8"	20PCS
MEAS	48×34×36CM	
QTY	144SETS/CTN (24SETS/INNER BOX)	
G.W/N.W	6/4KG	



75PCS PACKING

ITEM NO.	D12-75	
DETAIL	2.5×100MM 4"	25PCS
	3.6×150MM 6"	25PCS
	4.8×200MM 8"	25PCS
MEAS	36×34×34CM	
QTY	144SETS/CTN (36SETS/INNER BOX)	
G.W/N.W	8/6KG	





扎帶槍 TIE GUN

TG-1 扎帶槍

快速將束帶拉緊並切斷，適用束帶寬度為2.4mm-4.8mm只適用於“手動”

TG-1 TIE GUN

For tensioning and cut-off cable tie form 2.4mm to 4.8mmFor “DIY” ONLY



TG-2 扎帶槍

快速將束帶拉緊並切斷，適用束帶寬度為2.4mm-4.8mm

材質：塑膠制，鐵制

TG-2 TIE GUN

For fast, safe tensioning and cut-off of cable tie form 2.4mm to 4.8mm

Material: Plastic, steel.



TG-3 扎帶槍

快速將束帶拉緊並切斷，適用束帶寬度為

2.4mm-4.8mm

材質：塑膠制，鐵制

TG-3 TIE GUN

For fast, safe tensioning

and cut-off of cable tie

form 2.4mm to 4.8mm

Material: Plastic, steel.



TG-3 包裝

裝箱尺寸：45×32×35cm

數量：60套/箱

毛淨重：14.5/16kg

MEAS:45×32×35cm

QTY: 60 SETS/CTN

G.W / N.W:14.5/16kg



TG-6 扎帶槍

快速將束帶拉緊並

切斷，適用束帶寬

度為2.4mm-4.8mm

只適用於“手動”

TG-6 TIE GUN

For tensioning and

cut-off cable tie

fom2.4mmto4.8mm

For “DIY” ONLY



TG-6 包裝

裝箱尺寸：50×40×23

數量：100套/箱

毛/淨重：18/16kg

MEAS:50×40×23cm

QTY:100 SETS/CTN

G.W/N.W:18/16kg

TWO

wire/cable strap 電綫捆綁帶/不銹鋼扎帶卡箍
stainless steel cable ties



黏扣帶(魔鬼氈/子母扣) Hook & Loop Cable Ties(Velcro)

材質：尼龍。

特點：1. 黏性強不易脫落，不浪費可重複使用，收尾時，剩余的束帶長度可繼續纏繞黏。
2. 束緊力緩和不會傷害高性能之電纜線。

Material: nylon.

Usage: 1. Stickiness off strong is not easy, non-reusable waste, ending when the remaining length of the band can continue winding sticky carpet.
2. Force will not hurt to ease the high-performance cable.

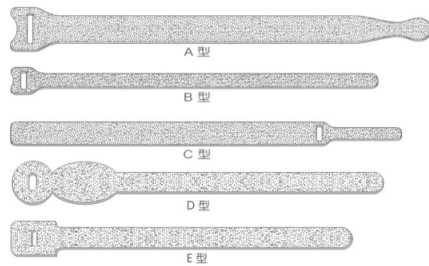

型號 Type	編號 Cat. No.	寬 W	長 L	捆扎範圍 Bundle Diameter	包裝 Std. Pkg pcs
A	HT-200A	12	200	5-40	20
	HT-250A	22	250	8-65	
B	HT-125B	12	125	5-25	20
	HT-150B	12	150	5-30	
	HT-200B	8	200	5-40	
	HT-200B	12	200	5-40	
	HT-230B	13	230	5-53	
	HT-240B	13	240	5-55	
C	HT-110C	10	110	5-18	20
	HT-170C	12	170	5-35	
D	HT-175D	13	175	5-35	20
E	HT-225E	13	225	5-52	



電綫綁帶 WIRE / CABLE STRAP SERIES

規格 Specification	規格 Specification	規格 Specification	規格 Specification	規格 Specification	規格 Specification
16×200	20×250	25×250	30×300	38×400	50×500
16×250	20×300	25×300	30×350	38×450	50×600
16×300	20×350	25×350	30×400	38×500	50×700
16×350	20×400	25×400	30×450	38×550	50×800
16×400	20×450	25×450	30×500	38×600	50×900
16×450	20×500	25×500	30×550	38×650	50×1000
16×500	20×550	25×550	30×600	38×700	50×1100
16×550	20×600	25×600	30×650	38×750	50×1200
16×600	20×650	25×650	30×700	38×800	50×1300
16×650	20×700	25×700	30×750	38×850	50×1400
16×700	20×750	25×750	30×800	38×900	50×1500
16×750	20×800	25×800	30×850	38×950	50×1600
16×800	20×850	25×850	30×900	38×1000	50×1800
16×850	20×900	25×900	30×950	38×1100	
16×900	20×950	25×950	30×1000	38×1200	
16×1000	20×1000	25×1000	30×1200	38×1500	

注：專業綁帶加工製造，可依客戶尺寸樣式，配合開模制作
Note: Customer can select required products, according to their actual requirements.

電綫綁帶 WIRE / CABLE STRAP SERIES

型號 Type	編號 Cat. No.	寬 W	長 L	捆紮範圍 Bundle Diameter	包裝 Std. Pkg pcs
F	HT-160A	15	160	5-30	20
	HT-250A	22	250	8-65	
G	HT-200A	20	200	5-40	20
	HT-250A	22	250	8-65	
H	HT-110A	10	110	5-20	20
	HT-205A	12	205	8-40	

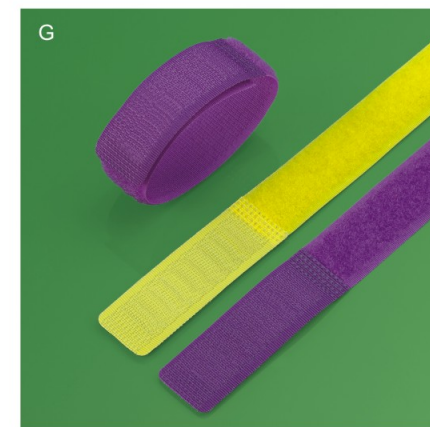
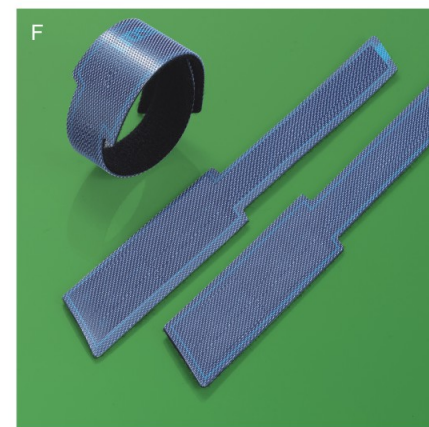

小包裝系列 D.I.Y PACKETS SERIES



一般粘扣帶 FASTENING TAPE

長度：每25米一卷。
 幅寬：16、20、25、30、38、50、75、100、125mm，並可依客戶需求剪裁。
 length: 25mm per roll.
 width: 12.5, 16, 20, 25, 30, 38, 50, 75, 100, 125mm.

包裝方式如下表如示 PACKING INFORMATION

幅寬 WIDTH	每卷長度 YARD/ROLL	每箱卷數 ROLL/CASE	每箱總長度 QUANTITY
16mm	27.5y/r	60r	1650y
20mm	27.5y/r	50r	1375y
25mm	27.5y/r	40r	1100y
30mm	27.5y/r	32r	880y
38mm	27.5y/r	28r	770y
50mm	27.5y/r	20r	550y
75mm	27.5y/r	14r	385y
100m	27.5y/r	10r	275y

基本色共35色，交期準確、服務快速。粘扣帶染因鈎毛面的材質差異大(鈎面為單絲，毛面為復絲)易產生色差，面邊和帶身因組織不同，在染整上色時，也有所不同，一般對色率以80%為可接受之標準。
 30 standard colors are available for our book&loop tapes. Because it is different to organize, different to some extent while dyeing generally regard 80% as the acceptable standard to the color rate.



不銹鋼緊鎖鋼珠扎帶(201-304-316)

STAINLESS STEEL LOCK STEEL BALL TIES

標準及特點

不銹鋼電纜紮帶的技術性能完全符合IEC92號《船舶電氣設備》和GB1113-85《包塑金屬電纜紮帶》及《鋼質海船入級與建造規範》有關規定。紮帶正常工作條件環境溫度-25℃—160℃，拉力≥500N，本體材質ICr18Ni9。適用於露天、潮濕、高溫等室內外場所捆紮電纜，具有抗磨、抗腐蝕、抗放射和防火性能。

Standard and characteristic

Stainless steel cable technical feature brought to pitch accord with " electric equipment of boat ", No. of IEC92, totally " is it mould with GB1113-85 metal cable is it bring to pitch to make " and " steel seagoing vessel enter magnitude and build norm " relevant regulation. Pitch and take the normal environment temperature of condition of work - 25 degrees Centigrade - 160 degrees Centigrade, ≥ 500N of pulling force, noumenonn material ICr18Ni9. Suitable for tying up the cable in the internal and external places of the room, such as in the open, humidity, high temperature ,etc., wear resistance, corrosion resistance, radiation resistance, fire protection.

規格 Specification	承受力 Min Loop Tensile		規格 Specification	承受力 Min Loop Tensile		規格 Specification	承受力 Min Loop Tensile		規格 Specification	承受力 Min Loop Tensile	
	lbs	Kg		lbs	Kg		lbs	Kg		lbs	Kg
4.6 × 127	135	60	7.9 × 150	180	80	10 × 150	225	100	12 × 200	270	120
4.6 × 152			7.9 × 200			10 × 200			12 × 250		
4.6 × 200			7.9 × 250			10 × 250			12 × 300		
4.6 × 250			7.9 × 300			10 × 300			12 × 350		
4.6 × 300			7.9 × 350			10 × 350			12 × 400		
4.6 × 350			7.9 × 400			10 × 400			12 × 450		
4.6 × 400			7.9 × 450			10 × 450			12 × 500		
4.6 × 450			7.9 × 500			10 × 500			12 × 550		
4.6 × 500			7.9 × 550			10 × 550			12 × 600		
4.6 × 550			7.9 × 600			10 × 600			12 × 650		
4.6 × 600			7.9 × 650			10 × 650			12 × 700		
4.6 × 650			7.9 × 700			10 × 700			12 × 750		
4.6 × 700			7.9 × 750			10 × 750			12 × 800		
4.6 × 750			7.9 × 800			10 × 800			12 × 850		
4.6 × 800			7.9 × 850			10 × 850			12 × 900		
									12 × 950		
			12 × 1000								
			12 × 1050								
			12 × 1100								
			12 × 1200								



萬能鋼帶箍 STAINLESS STEEL TIE (LADDER TYPE)

型號 ITEM.NO.	最大綁紮範圍 Max Bundle Dia		長度 "L" Length Approx		寬度 "W" Width Approx		承受力 Min Loop Tensile		包裝數量 Pkg. Qty.
	inch	mm	inch	mm	inch	mm	lbs	Kg	
HT-150S	0.86"	22	5.9"	150	0.28"	7	250	113.4	100
HT-195S	1.7"	45	8"	195					
HT-255S	2.5"	64	10"	255					
HT-335S	3.5"	89	13"	335					
HT-490S	5.4"	139	19"	490					
HT-635S	7.2"	185	25"	635					
HT-150M	0.86"	22	5.9"	150	0.472"	12	250	113.4	100
HT-195M	1.7"	45	8"	195					
HT-255M	2.5"	64	10"	255					
HT-335M	3.5"	89	13"	335					
HT-490M	5.4"	139	19"	490					
HT-635M	7.2"	185	25"	635					

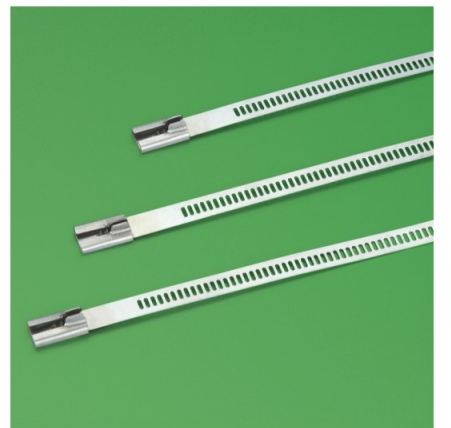



不銹鋼捆綁帶 UNIVERSAL CLAMPING BAND

不銹鋼捆綁帶,所採用國際先進技術、進口設備與材料生產製造。它是由紮帶、紮扣配套將物體固定、捆綁、束緊、安裝用的新型緊固卡具。無論在陸地、海洋或天空,不管是工業、農業、運輸、通訊、電力、化工、交通、城建等廣泛用於各個領域。

The stainless steel trusses up bringing, the international advanced technology, import equipment and material adopted are manufactured. It is it take, is it is it form a complete set object regular, truss up, tighten, install use new-type to fasten the fixture to deduct to pitch to pitch. No matter on the land, the ocean or the sky, no matter industry, agriculture, transportation, communication, electricity, chemical industry, traffic, urban construction, etc. are used in each field extensively.

預制卡箍式 Caliper prefabricating type

型號 Model no	規格 Specification	單位 Unit	使用範圍 Use range(mm)
HT1006	10×0.6	個	Φ25~Φ250
HT1606	16×0.6	個	Φ25~Φ250
HT1008	10×0.8	個	Φ37~Φ250
HT1608	16×0.8	個	Φ50~Φ300
HT1908	19×0.8	個	Φ75~Φ500

預制條狀式 Strip prefabricating type

型號 Model no	規格 Specification	單位 Unit	使用範圍 Use range(mm)
HT1006	10×0.6	個	80~800
HT1606	16×0.6	個	80~800
HT1008	10×0.8	個	120~800
HT1608	16×0.8	個	160~1000
HT1908	19×0.8	個	240~1500

- 特殊規格歡迎定做。
- 以上所有規格之不銹鋼紮帶的帶身皆可噴塑。
- Other size are available as requested.
- The body of the above specification stainless steel cable ties can be plastic-coating

萬能鋼噴鋼帶箍 STAINLESS EPOXY COATED STEEL TIE (LADDER TYPE)



型號 ITEM.NO.	最大綁紮範圍 Max Bundle Dia		長度 "L" Length Approx		寬度 "W" Width Approx		承受力 Min Loop Tensile		包裝數量 Pkg. Qty.
	inch	mm	inch	mm	inch	mm	lbs	Kg	
HTP-150S	0.86"	22	5.9"	150	0.28	7	250	113.4	100
HTP-195S	1.7"	45	8"	195					
HTP-255S	2.5"	64	10"	255					
HTP-335S	3.5"	89	13"	335					
HTP-490S	5.4"	139	19"	490					
HTP-635S	7.2"	185	25"	635					
HTP-150M	0.86"	22	5.9"	150	0.472	12	250	113.4	100
HTP-195M	1.7"	45	8"	195					
HTP-255M	2.5"	64	10"	255					
HTP-335M	3.5"	89	13"	335					
HTP-490M	5.4"	139	19"	490					
HTP-635M	7.2"	185	25"	635					

不銹鋼噴塑紮帶-自鎖式

STAINLESS STEEL EPOXY COATED CABLE TIES-BALL LOCK TYPE

標準及特點

不銹鋼電纜紮帶的技術性能完全符合IEC92號《船舶電氣設備》和GB1113-85《包塑金屬電纜紮帶》及《鋼質海船入級與建造規範》有關規定。紮帶正常工作條件環境溫度-25℃—160℃, 拉力≥500N, 本體材質ICr18Ni9。適用於露天、潮濕、高溫等室內外場所捆紮電纜, 具有抗磨、抗腐蝕、抗放射和防火性能。

Standard and characteristic

Stainless steel cable technical feature brought to pitch accord with " electric equipment of boat ", No. of IEC92, totally " is it mould with GB1113-85 metal cable is it bring to pitch to make " and " steel seagoing vessel enter magnitude and build norm " relevant regulation. Pitch and take the normal environment temperature of condition of work - 25 degrees Centigrade - 160 degrees Centigrade, ≥ 500N of pulling force, noumenonn material ICr18Ni9. Suitable for tying up the cable in the internal and external places of the room, such as in the open, humidity, high temperature, etc., wear resistance, corrosion resistance, radiation resistance, fire protection.

規格 Specification	承受力 Min Loop Tensile		規格 Specification	承受力 Min Loop Tensile		規格 Specification	承受力 Min Loop Tensile		規格 Specification	承受力 Min Loop Tensile	
	lbs	Kg		lbs	Kg		lbs	Kg		lbs	Kg
4.6 × 127	135	60	7.9 × 150	180	80	10 × 150	225	100	12 × 200	270	120
4.6 × 152			7.9 × 200			10 × 200			12 × 250		
4.6 × 200			7.9 × 250			10 × 250			12 × 300		
4.6 × 250			7.9 × 300			10 × 300			12 × 350		
4.6 × 300			7.9 × 350			10 × 350			12 × 400		
4.6 × 350			7.9 × 400			10 × 400			12 × 450		
4.6 × 400			7.9 × 450			10 × 450			12 × 500		
4.6 × 450			7.9 × 500			10 × 500			12 × 550		
4.6 × 500			7.9 × 550			10 × 550			12 × 600		
4.6 × 550			7.9 × 600			10 × 600			12 × 650		
4.6 × 600			7.9 × 650			10 × 650			12 × 700		
4.6 × 650			7.9 × 700			10 × 700			12 × 750		
4.6 × 700			7.9 × 750			10 × 750			12 × 800		
4.6 × 750			7.9 × 800			10 × 800			12 × 850		
4.6 × 800			7.9 × 850			10 × 850			12 × 900		
									12 × 950		
			12 × 1000								
			12 × 1050								
			12 × 1100								
			12 × 1200								



不銹鋼扎扣 STAINLESS STEEL BUCK

材質: 304 不銹鋼。

用途: 適用於電纜和管道的絕緣、捆綁和固定。

Material: 304 Grade stainless steel

Usage: Ideal for fixing insulation, bunding and securing of cables and pipes

型號 Model no	適合寬度 To Fit Band of Width(mm)	適合寬度 To Fit Band Width(mm)
HT-SSB-9-3/8	9.5	3/8
HT-SSB-12-1/2	12.7	1/2
HT-SSB-16-5/8	16.0	5/8
HT-SSB-19-3/4	19.0	3/4

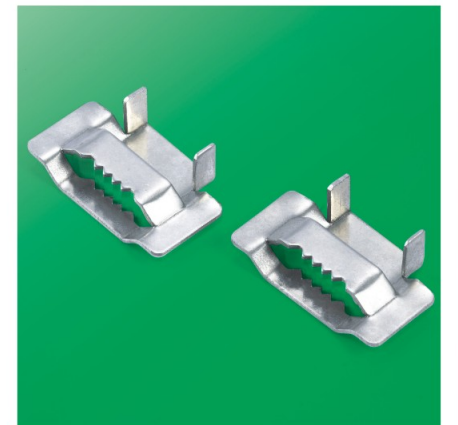



不銹鋼噴塑扎帶-L型鎖緊式

STAINLESS STEEL EPOXY COATED CABLE TIES-WING LOCK TYPE

不銹鋼噴塑捆綁帶,所採用國際先進技術、進口設備與材料生產製造。它是由紮帶、紮扣配套將物體固定、捆綁、束緊、安裝用的新型緊固卡具。無論在陸地、海洋或天空,不管是工業、農業、運輸、通訊、電力、化工、交通、城建等廣泛用於各個領域。

The stainless steel trusses up bringing, the international advanced technology, import equipment and material adopted are manufactured. It is it take, is it it form a complete set object regular, truss up, tighten, install use new-type to fasten the fixture to deduct to pitch to pitch. No matter on the land, the ocean or the sky, no matter industry, agriculture, transportation, communication, electricity, chemical industry, traffic, urban construction, etc. are used in each field extensively.

規格 Specification	規格 Specification	規格 Specification
10×150	12×150	15×200
10×200	12×200	15×250
10×250	12×250	15×300
10×300	12×300	15×350
10×350	12×350	15×400
10×400	12×400	15×450
10×450	12×450	15×500
10×500	12×500	15×550
10×550	12×550	15×600
10×600	12×600	15×650
10×650	12×650	15×700
	12×700	15×750
		15×800
		15×1000



不銹鋼噴塑扎帶-D型鎖緊式

STAINLESS STEEL EPOXY COATED CABLE TIES-RING TYPE

規格 Specification	規格 Specification
10×150	12×150
10×200	12×200
10×250	12×250
10×300	12×300
10×350	12×350
10×400	12×400
10×450	12×450
10×500	12×500
10×550	12×550
10×600	12×600
10×650	12×650
	12×700
	12×800



不銹鋼電纜扎帶底座 STAINLESS STEEL CABLE TIES MOUNTS

材質: 3304/316級不銹鋼。

用途: 適用電纜紮帶安裝座,設計用於不銹鋼電纜紮帶,帶有M4或M6固定孔,以適應各種固定方法。

Material: 304/316 Grade Stainless steel.

Usage: A durable and strong cable tie mount, designed to compliment stainless steel cable ties Available with either an M4 or M6 fixing hole to accommodate a wide range of fixing methods.

型號 MODEL NO	長(L)		寬(W)		高(H)		固定孔 Fixing Hole Size		最大紮帶寬度 Max Tie With	
	INCH	MM	INCH	MM	INCH	MM	INCH	MM	INCH	
HT-SSTM4	1.15"	29.2	0.6"	15.0	0.2"	5.2	0.17"	4.2	0.39"	10
HT-SSTM6	1.15"	29.2	0.6"	15.0	0.2"	5.2	0.24"	6.2	0.39"	10

固定頭尼龍不銹鋼嵌片扎帶

MOUNTABLE NYLON STAINLESS STEEL INLAY BLOCK TIES

標準及特點

尼龍紮帶技術性能完全符合IEC92-3-84標準和GB3126-82《船舶非金屬電纜紮帶》專業標準。紮帶使用環境溫度-25℃—60℃,抗拉強度符合標準要求。

Standard and characteristic

Nylon is it bring technical feature accord with IEC92-3-84 standard and GB3126-82 " boat nonmetal cable is it lead to pitch " professional standard totally to pitch. Pitching bringing environment temperature - 25 degrees Centigrade - 60 degrees Centigrade of use, tensile strength accords with the standard request.

材質及特點

採用尼龍66材料制成,具有絕緣性能好,難燃性,操作方便,省工省本等特點。

Material and characteristic

Adopt 66 materials of nylon to make, insulating and of good performance, difficult firing, easy to operate, the characteristics, such as one of worker's province in the province, etc..

型號 ITEM NO.	長L		寬W MM	(最大) 捆紮範圍 MAX.BUNDLE DIA. MM	承受力 TENSILE STRENGTH		包裝 PACKING
	INCH	MM			LBS	KGS	
HT-100MH	4"	100	2.5	22	18	8.0	100PCS
HT-100MA	4"	100	3.6	22	40	18	
HT-150MH	6"	150		32			
HT-200MH	8"	200	4.8	42	50	22	
HT-300MH	12"	300	7.2	80	50	55	
HT-200MA	8"	200	7.2	50	120	55	
HT-350MA	14"	350	7.2	90	120	55	
HT-380MA	14"	380	7.2	90	120	55	

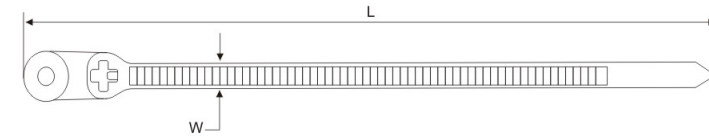

尼龍不銹鋼嵌片扎帶 NYLON STAINLESS STEEL INLAY BLOCK TIES

產品材料: 尼龍66;

嵌片材料: 不銹鋼316或304;

溫度範圍: -40℃to85℃

常規顏色: 本色或者黑色;

防火等級: U94V-2; 抗UV材質, 建議在室外使用

Product Material: Nylon 66,

Embedded material: Stainless steel 316 or 304

Temperature range: -40℃ to 85℃,

General color: Natural or black

Fire Rating: UL94V-2, UV resistant material, recommended for outdoor use

型號 ITEM NO.	長L		寬W MM	(最大) 捆紮範圍 MAX.BUNDLE DIA. MM	承受力 TENSILE STRENGTH		包裝 PACKING
	INCH	MM			LBS	KGS	
HTE-2.5×100	4.0"	100	2.5	3.0-20.5	27	12.0	100
HTE-2.5×160	6.3"	160		3.0-39.8			
HTE-2.5×200	8.0"	200		3.0-52.5			
HTE-3.6×140	5.5"	140	3.6	3.5-33.0	44	20.0	100
HTE-3.6×200	8.0"	200		3.5-52.5			
HTE-3.6×300	11.8"	300		3.0-84.0			
HTE-3.6×370	14.5"	370		3.0-106.0			
HTE-4.8×200	8.0"	200	4.8	3.5-49.5	60	27.0	100
HTE-4.8×250	10.0"	250		3.5-65.0			
HTE-4.8×300	11.8"	300		3.0-81.0			
HTE-4.8×370	14.5"	370		3.5-103.5			
HTE-7.6×220	8.6"	220	3.6	8.5-57.2	130	60.0	100
HTE-7.6×300	11.8"	300		8.5-82.8			
HTE-7.6×370	14.5"	370		8.5-103.5			
HTE-7.6×460	18.0"	460		8.5-130.5			
HTE-7.6×620	24.4"	620		8.5-181.5			



新品 NEW



新品 NEW



HT-001-A 萬能鋼帶箍 STAINLESS STEEL BAND CLAMP

標準及特點

萬能鋼帶箍又名：卡箍、滿意夾、主要用於電線桿上捆紮電纜、接地線、支架、吊牌等、同樣適用於電氣化鐵路、電信局電桿、交通紅綠燈及標誌桿等部門。

詳細說明：

- 1、萬能鋼帶箍由金具、棘輪、箍帶等零件組合而成，金具選用1MM優質不銹鋼沖制成型。箍帶選用厚度0.2MM，寬度14MM不銹鋼經折邊後成10MM。箍帶具有非常的強度和拉力，及光滑的邊緣。
- 2、萬能鋼帶箍具有超強的緊固力，使用時十分方便，只要來回撥動金具就可以達到抽緊的目的，最後用力一按就會自動鎖緊。
- 3、箍帶的長短可由用戶根據需要而定制，目前有400mm、600mm、800mm、1000mm、1200mm、1500mm、2000mm等規格。

Standard and characteristic

Stainless steel band clamps (clip band, satisfaction clip) is mainly used not only for attaching cable, grounding conductors etc, but also for electrification railway, pole of telecommunication, traffic lights and singpole, etc.

The detail is as following:

1. Stainless steel band clamps is consisted of belt, clamp, ratch wheel and so on. The clamp is made of high quality 1mm thickness stainless steel. The belt is also made of stainless steel whose width is 14mm and thickness is 0.2mm. After the two edges of the belt are hemmed, the width of the belt is 10mm. The belt has strong intension and pull. The two edges of the belt are smooth.
2. Stainless steel band clamps are convenient to use. The clamp is capable of easily attaching, detaching or fastening the belt, and it can not be liable to loosen inadvertently.
3. The length of stainless steel band clamps is in accordance to customer's requirement. At present there are 400mm, 600mm, 800mm, 1000mm, 1200mm, 1500mm, 2000mm specifications and so on.

型號 ITEM.NO.	最大綁紮範圍 Max Bundle Dia		長度 "L" Length Approx		寬度 "W" Width Approx		"E" Head Approx		包裝數量 Pkg. Qty.
	inch	mm	inch	mm	inch	mm	inch	mm	
HT-1100	11.8	330	43.3	1100	.394	10.0	1.900	48.0	25
HT-1315	15.0	380	51.7	1315	.394	10.0	1.900	48.0	25

標誌帶 MARKER PLATE

型號 ITEM NO.	L(mm)	W(mm)	C(mm)
HTPS-4.5	88.9	9.5	5.9
HTPM-4.5	88.9	19.0	6.2

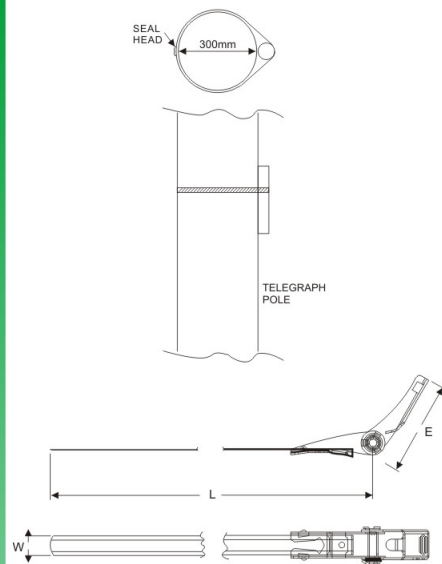
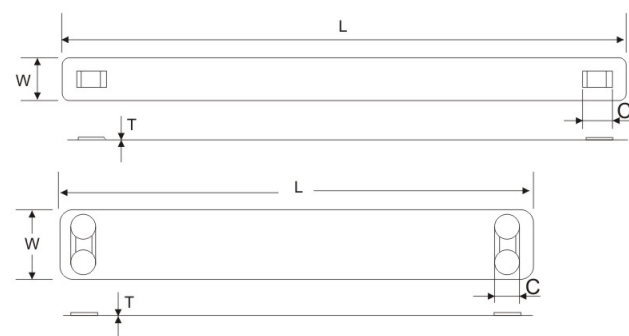

STAINLESS STEEL TIE (RELEASABLE TYPE WITH NYLON COATING)

型號 ITEM.NO.	最大綁紮範圍 Max Bundle Dia		長度 "L" Length Approx		寬度 "W" Width Approx		承受力 Min Loop Tensile		包裝數量 Pkg. Qty.
	inch	mm	inch	mm	inch	mm	lbs	Kg	
HTC-152S	1.5	38	6	152	0.25/0.38	6.3/9.5	300/450	136/204	100
HTC-229S	2.5	63	9	229					
HTC-305S	3.5	86	12	305					
HTC-457S	5.4	137	18	457					
HTC-610S	7.3	185	24	610					
HTC-762S	9.09	231	30	762					
HTC-914S	11.02	280	36	914					

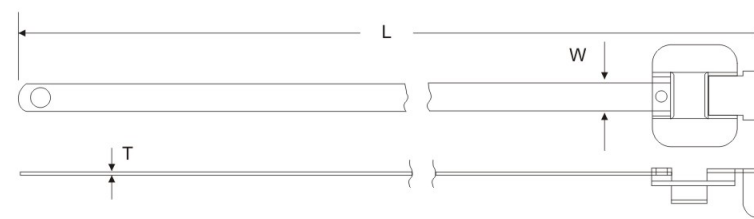

ZD帶式卡箍 ZD HOSE CLAMP

使用範圍 Use range (mm)	型號 Modelno			包裝數量 袋/箱 Packing Size	A	B	D	耐壓強度 Pressure -resistance strength (Mpa/cm ²)	抗扭矩值 Anti-torque (N.m)
	(L)帶寬 9mm Strip Width 9mm	(L)帶寬 12mm Strip Width 12mm	(L)帶寬 13mm Strip Width 13mm						
8-12	7610090012			100/2000	20	10	12	1.4	25-5
10-16	7610090016			100/2000	20	10	16	1.4	25-5
12-20	7610090020		7810130020	100/1000	20	10	20	1.4	25-5
12-22	7610090022		7810130022	100/1000	20	10	22	1.4	25-5
16-25	7610090025	7710120025	7810130025	100/1000	20	10	25	1.4	25-6
16-27	7610090027	7710120027	7810130027	100/1000	20	10	27	1.4	25-6
20-32	7610090032	7710120032	7810130032	100/1000	25	10	32	0.7	25-6
25-40	7610090040	7710120040	7810130040	100/1000	25	10	40	0.7	35-7
30-45	7610090045	7710120045	7810130045	100/1000	25	10	45	0.7	35-7
32-50	7610090050	7710120050	7810130050	100/1000	25	10	50	0.7	35-7
40-60	7610090060	7710120060	7810130060	100/1000	25	10	60	0.7	35-7
50-70	7610090070	7710120070	7810130070	50/500	25	10	70	0.7	35-7
60-80	7610090080	7710120080	7810130080	50/500	25	10	80	0.3	5-10
70-90	7610090090	7710120090	7810130090	50/500	25	10	90	0.3	5-10
80-100	7610090100	7710120100	7810130100	20/300	25	10	100	0.3	5-10
90-110	7610090110	7710120110	7810130110	20/300	25	10	110	0.3	5-10
100-120	7610090120	7710120120	7810130120	20/300	25	10	120	0.3	5-10
110-130	7610090130	7710120130	7810130130	20/300	25	10	130	0.3	5-10
120-140	7610090140	7710120140	7810130140	20/300	25	10	140	0.3	5-10
130-150	7610090150	7710120150	7810130150	20/300	25	10	150	0.3	5-10
140-160	7610090160	7710120160	7810130160	20/300	25	10	160	0.3	5-10

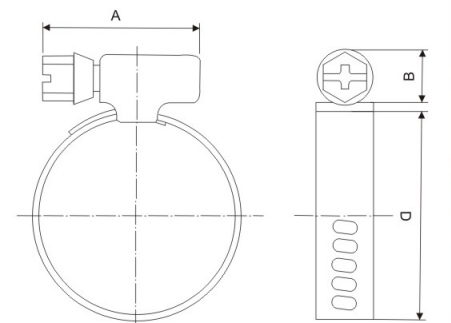

THREE nail cable clips series 鋼釘電纜卡系列



圓型鋼釘線卡系列 CIRCLE CABLE CLIPS

材質：採用PE材料制成，附鋼釘。

使用方法：將電線置於卡內，用鐵錘將鋼釘釘上牆壁上即可將電線固定。

用途：一般室內配線固定電線用。

Material: PE, Steel nail.

How to use: Put the cable under the clip and hammer the nail into the wall to secure the cable.

Application: Securing of cables for general indoor wiring.

型號 ITEM NO.	高 H MM	圓徑 R MM	鋼釘 Nail MM	包裝 PACKING
4mm	5.3	4	1.7 × 15	100pcs
5mm	6.5	5	1.7 × 15	
6mm	8.1	6	1.7 × 17	
7mm	8.7	7	1.8 × 20	
8mm	9.6	8	1.9 × 20	
9mm	10.7	9	2.0 × 22	
10mm	11.7	10	2.0 × 25	
12mm	12.8	12	2.05 × 27	
14mm	14.9	14	2.4 × 32	
16mm	16.9	16	2.5 × 35	
18mm	20.8	18	2.5 × 37	
20mm	23.6	20	2.8 × 40	
22mm	25.0	22	2.8 × 42	
25mm	27.7	25	3.0 × 48	
28mm	33.1	30	3.2 × 53	
32mm	36.6	35	3.5 × 58	
40mm	45.2	40	3.5 × 68	

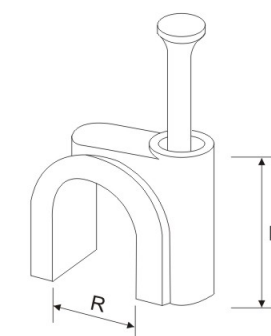

梅花型鋼釘線卡系列 HOOK CABLE CLIPS

材質：PE

Material: High impact PE

型號 ITEM NO	外高 H (MM)	寬 W	鋼釘 Nail MM	包裝 PACKING
5mm	8.5	5	2.5 × 20	100pcs
6mm	10.2	6	2.5 × 25	
7mm	10.6	7	2.5 × 25	
8mm	11.4	8	2.5 × 20	



鈎型鋼釘線卡系列 HOOK CABLE CLIPS

材質：PE(白色)

Material: High impact PE

型號 ITEM NO.	寬 W	鋼釘 Nail MM	包裝 PACKING
HT-0507	5~7	1.2 × 20	100pcs
HT-0710	7~10	1.7 × 25	
HT-0812	8~12	1.8 × 25	
HT-1014	10~14	2.0 × 30	
HT-1115	11~15	2.0 × 30	
HT-1619	16~19	2.6 × 38	
HT-1420	14~20	2.6 × 38	
HT-1620	16~20	2.8 × 50	





鈎型鋼釘綫卡系列 HOOK CABLE CLIPS

型號 ITEM NO.	寬 W	鋼釘Nail MM	包裝 PACKING
HT-0407	4-7	1.9×30	100pcs
HT-0712	7-12	1.9×35	
HT-1014	10-14		

新品
NEW

方型鋼釘綫卡系列 SQUARE CABLE CLIPS

材質：採用PE材料制成，附鋼釘。

使用方法：將電線置於卡內，用鐵錘將鋼釘釘上牆壁上即可將電線固定。

用途：一般室內配線固定電線用。

Material: PE, Steel nail.

How to use: Put the cable under the clip and hammer the nail into the wall to secure the cable.

Application: Securing of cables for general indoor wiring.

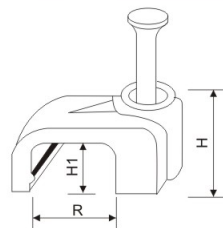

型號 ITEM NO.	外高 H (MM)	內徑 Circle Path		鋼釘Nail (MM)	包裝 PACKING
		H1(MM)	R(MM)		
4mm	6.0	3.8	4	1.7×15	100pcs
5mm	6.0	3.8	5		
6mm	6.5	4.1	6		
7mm	7.0	4.7	7	1.8×20	
8mm	7.5	5.0	8		
9mm	8.2	5.4	9	2.0×22	
10mm	8.6	5.7	10		
12mm	9.0	6.1	12	2.05×27	
14mm	11.2	6.5	14		
16mm	11.6	8.4	16	2.4×32	
20mm	13.6	10.2	20		

雙釘式白扁電綫固定卡 DOUBLE NAIL FLAT CABLE CLIPS

材質：PE

Material: High impact PE



型號 ITEM NO.	寬 W	內高 H	外高 H1	適用電綫 SUITABLE WIRES	鋼釘 NAILS	包裝 PACKING
HT-13	12.5	8	8	#14/2, 14/3, 12/2	1.86×31	100pcs
HT-19	18.7	8	8	#12/3, 10/2, 10/3	1.86×31	

鈎型鋼釘綫卡系列 HOOK CABLE CLIPS

材質：PE

Material: High impact PE



型號 ITEM NO.	寬 W	鋼釘Nail MM	包裝 PACKING
HT5-8	5~8	2.0×25	100pcs
HT6-10	6~10	2.0×25	
HT7-14	7~14	2.5×25	
HT9-18	9~18	2.5×30	

鋼釘綫卡(包裝系列E) PACKING OF SERIES E

型號 ITEM NO.	外箱尺寸 CM	數量 (100PCS/BAG) BAG/CTN	毛淨重 KG
4mm	48×35×32	600	30/29
5mm		500	26/25
6mm		450	29/28
7mm		400	30/29
8mm		300	29/28
9mm		200	22/21
10mm	48×35×35	200	24/23
12mm		150	25/24
14mm		100	21/19
16mm		70	22/20
18mm	55×33×47	60	22/20
20mm		40	19/17
22mm		60	31/29
25mm	40	26/24	

鋼釘綫卡(包裝系列F) PACKING OF SERIES F

型號 ITEM NO.	外箱尺寸 CM	只/盒 BAG/CTN	盒/箱 BAG/CTN	毛淨重 KG
4mm	40×34×39	100	400	27/25
5mm		100	400	29/27
6mm	48×35×37	100	300	27/25
7mm		100	300	30/28
8mm	48×35×35	100	200	24/22
9mm		100	200	26/24
10mm	52×44×33	100	180	30/29
12mm	52×37×26	100	100	28/26
14mm	52×44×33	50	180	27/25
	53×43×38	100	100	30/28
16mm	52×37×26	50	100	30/28
	53×43×38	100	100	35/33
18mm	53×43×38	50	100	26/34
	52×42×33	100	60	31/29
20mm	53×43×38	50	100	24/22
	52×42×33	100	60	33/31
22mm	53×43×38	50	100	32/30
25mm	53×42×33	50	60	25/23





鋼釘綫卡(包裝系列G) PACKING OF SERIES G

ITEM NO.	G1
DETAIL	7MM
MEAS	35.5×27.5×21CM
G.W/N.W	7/6KG

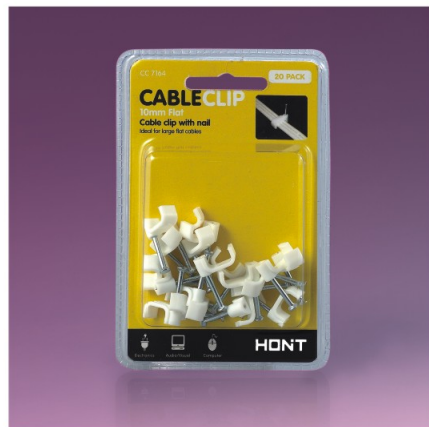

ITEM NO.	G2
DETAIL	8MM
MEAS	35.5×27.5×21CM
G.W/N.W	7/6KG



ITEM NO.	G3
DETAIL	6MM
MEAS	43×38×26CM 53×38×19CM
G.W/N.W	2.5/1.25KG/3/1.5KG



ITEM NO.	G4
DETAIL	6MM
MEAS	48×20×24CM
G.W/N.W	5/KG

鋼釘綫卡(包裝系列G) PACKING OF SERIES G

ITEM NO.	G5
DETAIL	7MM
MEAS	54×40×46CM
G.W/N.W	6/5KG

鋼釘綫卡(包裝系列H) PACKING OF SERIES H

1100PCS PACKING

ITEM NO.	H1-1100	
DETAIL	6MM	400PCS
	7MM	300PCS
	8MM	240PCS
	10MM	160PCS
MEAS	61×33×26CM	
G.W/N.W	20/18KG	

800PCS PACKING

ITEM NO.	H2-800	
DETAIL	4MM	350PCS
	6MM	200PCS
	8MM	150PCS
	10MM	100PCS
MEAS	59×40.5×18.5CM	
G.W/N.W	19/18KG	

K型固定夾 K TAPE CABLE CLAMPS

U-TYPE NAILS

型號 ITEM NO	A(mm)	B(mm)	Nail sizeφ(mm)
HT-5TRS	8.0	14.8	16.5
HT-5GRY	9.0	18.0	16.5

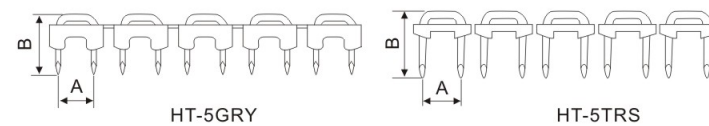

FOUR

wiring accessories

series 配綫器材系列



HT1系列無鹵阻燃熱收縮套管 HT1 SERIES HEAT-SHRINKABLE TUBE

功用:

- 1.電線之保護與絕緣。
- 2.端子與電接線頭之絕緣與保護。
- 3.分色作用。
- 4.防水。
- 5.電阻電容器之保護與絕緣標誌顏色(透光): 黑、白、紅、藍、黃、綠、棕、灰、橙、紫。

Apporved date:

UL2240,105°C,660V,VW-1,CSA,125°C,660V,OFT
 F:105°C(UL,CSA合格)
 F2: 125°C(UL,CSA合格)
 F32: 125°C(UL,CSA合格)

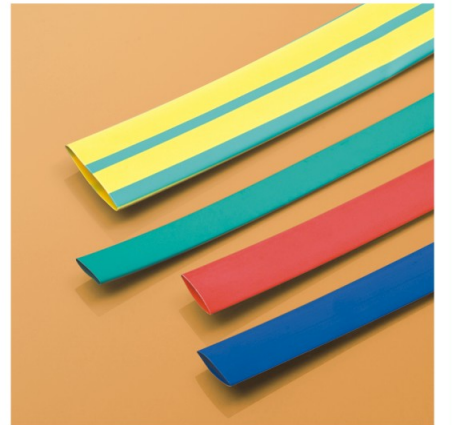

型號 ITEM NO.	收縮前AS SUPPLIED		收縮後AFTER SHRINKAGE		適用範圍 APPLICATION (mm)	包裝 PACKING (M/ROLL)
	內徑 I.D(mm)	厚度 THICKNESS	內徑 I.D(mm)	厚度 THICKNESS		
HT1-0.8	1.0±0.2	0.2±0.05	0.4±0.1	0.22±0.05	0.6~0.8	200
HT1-1.0	1.4±0.3	0.2±0.05	0.4±0.1	0.28±0.05	0.75~0.9	200
HT1-1.5	1.9±0.3	0.2±0.05	0.6±0.1	0.32±0.05	0.95~1.4	200
HT1-2.0	2.4±0.3	0.25±0.05	0.9±0.1	0.35±0.05	1.1~1.8	200
HT1-2.5	2.9±0.3	0.25±0.05	1.1±0.1	0.38±0.05	1.35~2.3	200
HT1-3.0	3.4±0.4	0.25±0.05	1.4±0.1	0.40±0.05	1.6~2.7	200
HT1-3.5	3.9±0.4	0.25±0.05	1.6±0.1	0.42±0.05	1.85~3.2	200
HT1-4.0	4.5±0.4	0.25±0.05	1.8±0.1	0.45±0.05	2.1~3.6	200
HT1-4.5	4.8±0.4	0.25±0.15	1.9±0.1	0.50±0.15	2.35~4.0	100
HT1-5.0	5.4±0.4	0.25±0.15	2.3±0.1	0.55±0.15	2.6~4.5	100
HT1-6.0	6.4±0.4	0.28±0.15	2.8±0.2	0.55±0.15	3.1~5.4	100
HT1-7.0	7.4±0.4	0.28±0.15	3.3±0.2	0.55±0.15	3.7~6.3	100
HT1-8.0	8.4±0.5	0.28±0.15	3.8±0.2	0.55±0.15	4.2~7.2	100
HT1-9.0	9.4±0.5	0.30±0.15	4.3±0.2	0.55±0.15	4.7~8.0	100
HT1-10	10.5±0.5	0.30±0.15	4.8±0.2	0.55±0.15	5.2~9.0	100
HT1-11	11.5±0.5	0.30±0.15	5.3±0.2	0.60±0.15	5.7~10	100
HT1-12	12.5±0.5	0.30±0.15	5.7±0.3	0.60±0.15	6.2~11	100
HT1-13	13.5±0.5	0.33±0.15	6.2±0.3	0.60±0.15	6.7~12	100
HT1-14	14.5±0.5	0.35±0.15	6.7±0.3	0.60±0.15	7.3~13	100
HT1-15	15.5±0.6	0.38±0.15	7.2±0.3	0.65±0.15	7.8~14	100
HT1-16	16.5±0.6	0.38±0.15	7.7±0.3	0.65±0.15	8.3~15	100
HT1-17	17.5±0.6	0.38±0.15	8.2±0.3	0.65±0.15	8.8~16	100
HT1-18	19.0±0.6	0.40±0.15	8.7±0.3	0.65±0.15	9.3~17	100
HT1-20	21.0±0.8	0.40±0.20	9.7±0.3	0.75±0.20	10.4~19	100
HT1-22	22.8±0.8	0.42±0.20	10.0±1.0	0.75±0.20	11.4~21	100
HT1-25	25.8±0.8	0.45±0.20	11.0±1.0	0.75±0.20	12.8~24	50
HT1-28	28.8±0.8	0.45±0.20	13.0±1.0	0.75±0.20	14.4~29	50
HT1-30	30.8±0.8	0.45±0.20	14.0±1.0	0.75±0.20	16~29	50
HT1-35	35.8±0.8	0.50±0.20	16.0±1.0	0.85±0.20	18~34	50
HT1-40	42.0±1.0	0.50±0.20	19.0±1.0	0.85±0.20	21~39	50
HT1-50	51.0±1.0	0.50±0.20	24.0±1.0	0.85±0.20	26~49	50
HT1-60	61.0±1.0	0.65±0.20	29.0±1.0	0.85±0.20	35~55	25
HT1-70	71.0±1.0	0.65±0.20	33.0±2.0	1.00±0.20	40~65	25
HT1-80	81.0±1.0	0.65±0.20	37.0±2.0	1.00±0.20	45~75	25
HT1-90	91.0±1.0	0.65±0.20	43.0±2.0	1.00±0.20	50~88	25
HT1-100	102.0±2.0	0.65±0.20	48.0±2.0	1.00±0.20	55~95	25
HT1-120	122.0±2.0	0.80±0.20	58.0±2.0	1.50±0.20	65~115	15
HT1-150	152.0±2.0	0.80±0.20	73.0±2.0	1.50±0.20	80~145	15
HT1-180	182.0±2.0	0.80±0.20	88.0±2.0	1.50±0.20	95~175	15

HT3系列雙壁熱收縮套管 HT3 SERIES DOUBLE-WALL HEAT-SHRINKABLE TUBE

特點及應用範圍:

- HT3系列是一種內層附有熱熔膠的半導性熱縮管。外層是由輻射交聯聚烯組成，內層是專門設計的膠性內壁；加熱時內壁熔膠，並隨外壁收縮填充收縮填充孔隙或縫隙，冷卻後，雙壁管壁厚均勻、堅實。廣泛應用於電子設備的接線防水防漏氣，電線分支處的密封固定，金屬管線的防腐保護，電線電纜的修補等均可，防止由高分子鏈鬆弛產生的鬆動和脫落，如水下燈飾、汽車油管、高級線束等。
- 特點：
 - 適用範圍：-55℃~125℃；
 - 起始收縮溫度計：70℃；
 - 完全收縮溫度計：125℃；
 - 內層膠層融化溫度：70℃~80℃。
 - 收縮倍率：3:1。
 - 密封、防水，應變能力大；使用方便，用烘箱和熱風槍加熱即可收縮；供貨及時，生產能力大。
 - 標準顏色：黑色(可按客戶要求提供其它顏色)。

Features and Application:

- HT3 series is a semi-conducting thermal shrinkable bushing coated with a layer of thermosol inside. Its external layer consists of radiation cross-linked polythene, and its internal layer is the specially designed adhesive internal wall. When it is heated, the internal thermosol will shrink to the external wall and fill the clearance. When it is cooled, the thickness of double walls is very even and solid. It is widely used for the water-tightness and air-tightness of wiring for electronic equipments, the sealing of wiring branch, rust protection of metal wires, and the remedy of wires and cables. It can prevent the polymer chains from loosening and falling, such as pool lamp, auto pipeline, and advanced lines.
- Features:
 - Application: -55℃ ~ 125℃;
 - Initial shrinking temperature: 70℃;
 - Full shrinking temperature: 125℃;
 - Melting temperature of internal adhesive layer: 70℃ ~ 80℃
 - Shrinking ratio: 3:1
 - Seal, water-proof, strong flexibility, convenient use, able to shrink when heated with oven or hot air gun; timely supply and delivery; and large production.
 - Color standard: Black (Other colors are upon the clients' needs).

型號 ITEM NO.	收縮前AS SUPPLIED		收縮後AFTER SHRINKAGE		適用範圍 APPLICATION (mm)	包裝 PACKING (M/ROLL)
	內徑 I.D.(mm)	厚度 THICKNESS	內徑 I.D.(mm)	厚度 THICKNESS		
HT3-2.4	2.7±0.3	0.7±0.15	0.30±0.10	0.80	0.9~2.2	200
HT3-3.2	3.5±0.3	0.90±0.15	0.35±0.10	1.00	1.0~3.1	200
HT3-4.8	5.1±0.3	1.0±0.15	0.40±0.10	1.60	1.8~4.6	100
HT3-6.4	6.8±0.4	1.2±0.15	0.45±0.12	2.20	2.4~6.4	100
HT3-7.9	8.3±0.4	1.3±0.15	0.50±0.12	2.70	2.9~7.7	100
HT3-9.5	9.9±0.4	1.4±0.15	0.50±0.12	3.20	3.4~9.4	1.22
HT3-12.7	13.2±0.5	1.6±0.20	0.50±0.12	4.20	4.4~12.5	1.22
HT3-15.0	15.5±0.5	1.8±0.20	0.55±0.12	5.20	5.4~14.8	1.22
HT3-19.1	19.6±0.5	2.0±0.20	0.55±0.12	6.30	6.5~18.8	1.22
HT3-25.4	26.2±0.8	2.1±0.20	0.55±0.15	8.50	8.8~25	1.22
HT3-30.0	30.5±0.8	2.2±0.20	0.60±0.15	10.2	10.5~30	1.22
HT3-39	39.8±0.8	2.4±0.20	0.60±0.15	13.5	14.0~9	1.22
HT3-50	50.0±0.8	2.7±0.25	0.70±0.15	17.0	17.5~49	1.22
HT3-64	≥64	3.0±0.25	0.70±0.15	21.0	22~62	1.22
HT3-75	≥76	3.0±0.30	1.00±0.20	25.0	26~72	1.22
HT3-90	≥90	3.0±0.30	1.00±0.20	30.0	32~88	1.22
HT3-100	≥100	3.0±0.30	1.00±0.20	34.0	36~90	1.22
HT3-125	≥125	3.0±0.30	1.00±0.20	42.0	44~125	1.22

HT扎帶固定座 CABLE TIE HOLDER

ITEM.NO.	H	H1	W	L	L1	PACKING
HT-6	31	6.0	8.0	12.7	9.7	100PCS
HT-8	37	6.0	10	12.7	9.7	100PCS

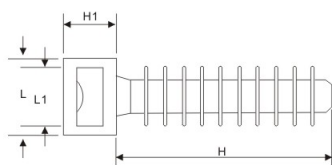

結束帶 FLEXIBEL CABLE CHANNEL

型號 ITEM NO.	規格 SIZE	包裝 PACKING	
HT-15A	Φ15mm	2.5m	10m
HT-20A	Φ20mm		
HT-25A	Φ25mm		
HT-30A	Φ30mm		

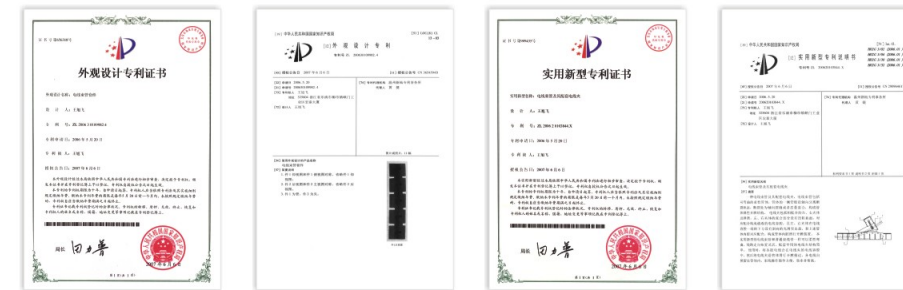

卷式纏繞帶 SPIRAL WRAPPING BAND

材質：採用PE料制成。

使用方法：先用保護帶固定起點一端，然後按順時針方向環繞束緊，即可將電線束為一體。

用途：作為保護電線不受磨損及絕緣用，並可改進電線彎曲的美觀。

Material: Made from PE.

Usage: fix one end with safety belt first, then circle the wires clockwise to make them tighten.

Application: a protection wear for electric wires, and make them insulation and look nice.



型號 ITEM NO.	內徑 D	外徑 D1	螺距 W	結束可能範圍 WRAPPING RANGE (mmΦ)	包裝 PACKING
HT-6	4	6	7.0	4×50	10m
HT-8	6	8	10.8	6×60	
HT-10	7.5	10	11.4	7.5×60	
HT-12	9	12	13.9	9×65	
HT-16	13	16	15.0	12×70	
HT-20	16	20	18.2	15×100	
HT-25	21	25	19.6	20×130	

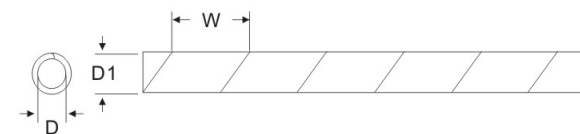

粘式扎綫固定座 CABLE TIE MOUNTS

材質：UL認可尼龍66，防火等級94V-2，可重複使用。

使用方法：將電纜置於固定扣內，再以螺絲固定。

Material: Nylon 66 94V-2 agreed by UL

Usage: Put cable in fix by screw.

型號 ITEM.NO.	長 L	寬 W	高 H	包裝 PACKING
HTC-18×20	20	18	26	100PCS



R型固定夾 R TYPE CABLE CLAMPS

材質: UL認可尼龍66, 防火等級94V-2, 可重複使用。 **Material:** Nylon 66 94V-2 agreed by UL
使用方法: 將電纜置於固定扣內, 再以螺絲固定。 **Usage:** Put cable in fix by screw.

型號 ITEM NO	A(mm)	B(mm)	C(mm)		D(mm)	包裝 PACKING
			mm	inch		
HT-1/8R	9.5	9.6	3.2	1/8"	19.8	100PCS
HT-3/16R	9.6	9.6	4.8	3/16"	19.8	
HT-1/4R	12.0	10.0	6.35	1/4"	22.0	
HT-5/16R	12.0	10.0	7.9	5/16"	22.0	
HT-3/8R	12.5	12.0	9.5	3/8"	24.0	
HT-1/2R	15.2	12.0	12.7	1/2"	31.0	
HT-5/8R	18.2	12.0	15.8	5/8"	34.3	
HT-3/4R	18.2	12.0	19.4	3/4"	35.0	
HT-1R	22.0	12.0	25.4	1"	43.0	
HT-17/16R	24.0	12.0	27.5	17/16"	50.0	
HT-5/4R	26.2	12.0	31.8	11/4"	46.2	
HT-3/2R	30.0	12.0	36.7	11/2"	50.0	

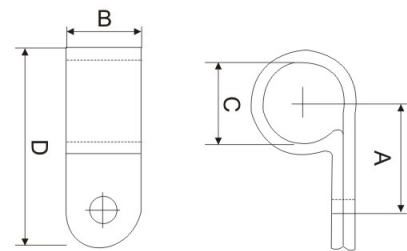
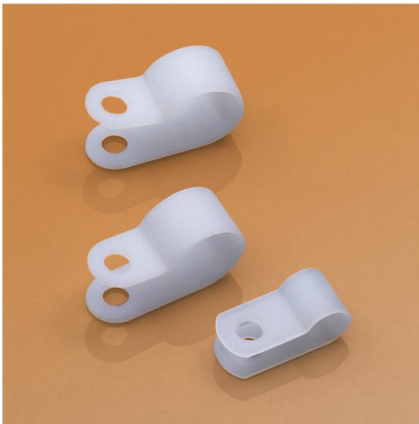

可調式扎綫固定座 ADJUST CABLE TIE MOUNTS

U-TYPE NAILS

型號 ITEM NO	L(mm)	W(mm)	包裝 PACKING
HTM-25	25	18	100PCS
HTM-37	37	18	
HTM-41	41	25	

新品 NEW

扎綫固定座 SADDLE TYPE TIE MOUNTS

材質: UL合格之NYLON 66(本色), 防火等級94V-2。
用途: 先將固定座以螺絲固定, 再以紮線帶繞綁電纜, 馬鞍形設計使電纜易於固定。
Material: UL approved Nylon 66, 94V-2
Application: Saddle design provide maximum stability to wire bundles. To apply, simply fix mount with a screw and secure wire bundles with HONT nylon cable ties.

型號 ITEM NO.	高 H	長 L	寬 W	帶孔 T	固定孔 B	包裝 Packing
HC-1	7	15	10	5	3	每包100PCS
HC-2	9	23	16	9	6	

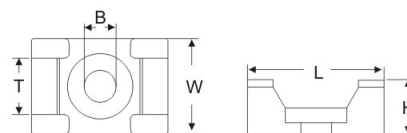
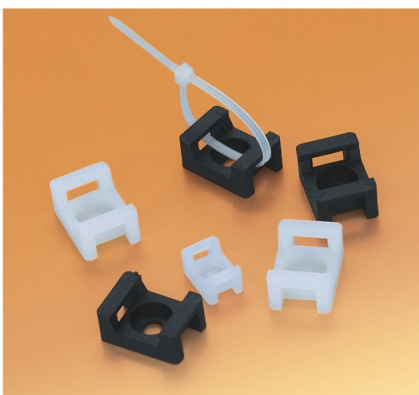

粘式扎綫固定座 CABLE TIE MOUNTS

材質: 採用UL認可之ABS, 尼龍66制成, 防火等級94V-2。背附進口面海膠, 絕緣性能良好、耐久性、不易老化。
使用方法: 將定位片背面雙面膠撕開, 貼於機板固定, 再用紮帶捆紮電纜。
用途: 省時、簡便、供面板不可以鉗孔時使用。
Material: UL approved Nylon 66, 94V-2, with imported adhesive sticker. Good insulation, long lasting and uneasy to age.
How to use: Remove the cover of the adhesive and stick the piece properly, then put in cable tie for using.
Application: Used where hole-drilling is not allowed. easy and time-saving.

型號 ITEM NO.	長×寬 L × W (MM)	高 H MM	帶孔 T MM	外箱尺寸 CM	數量 PCS/CTN	毛重/淨重 KG
HTA-20	20×20	6.1	5.0	52×35×36	20000	20/18
HTA-25	25×25	7.5	6.2	52×35×36	10000	19/17
HTA-30	30×30	8.7	6.4	54×33×32	6000	18/16
HTA-40	40×40	6.4	10.8	54×33×32	3000	17/15
HTB-25	25×25	7.5	6.2	52×35×36	10000	19/17
HTB-30	30×30	8.7	6.4	54×33×32	6000	18/16

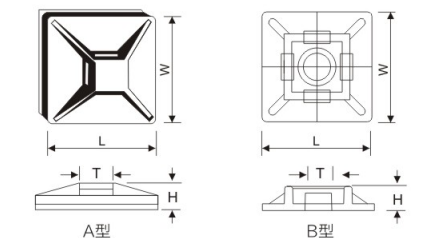

鐵扎綫(鐵芯扎綫帶) GALVANIZED PVC COATED WIRE

鐵紮線(鐵芯紮線帶): 也叫包膠鐵線(鍍鋅鐵絲紮線)、魔術帶(魔帶)、迷你帶、園藝紮線、包塑鐵線、鐵紮絲、環保紮帶、鐵心紮帶、鐵紮帶、PVC紮線、PVC紮絲、PVC紮帶, 主要用於玩具廠、工藝品廠、垃圾袋、園藝花卉、聖誕禮品廠、電子廠(電子產品)、線材加工廠、電線電纜廠(電源線、US線、CABLE線、網絡線、電腦周邊連接線、音視頻線)、喜慶節日、文具百貨、新鮮超市、民居日用、電工電器、接插件、五金等物品的捆紮。
 Iron Tie Line (Iron core tie): Also known as coated wire (galvanized wire tie), Magic Belt (Magic Belt), mini belt, horticultural line, plastic wire, Tiezas, environmental protection tie, iron core tie, iron tie, PVC tie line, PVC Taze, PVC tie, Mainly used for toy factory, handicraft factory, garbage bag, horticultural flowers, Christmas gift factory, electronics Factory (electronic products), wire processing plant, wire and cable factory (power cord, US line, cable line, network line, computer peripheral cable, audio and video line), festive festival, stationery department store, fresh supermarket, residential daily, electrical appliances, connectors, hardware and other items of strapping.

品名 PRODUCT NAME	編號 ITEM.NO.	包塑後 寬度(扁型) AFTER PLASTIC COATED WIDTH mm	包塑後 寬度(圓型) FLAT TYPE CIRCLE TYPE	重量\卷 WEIGHT	長度\卷 LENGTH	包裝 (件) PACKING	備註 REMARKS	
鍍鋅鐵絲紮線 GALVANIZED PVC COATED WIRE	HT-0.45	2.1	1.0	300克	約95米	50卷	材質: PVC電纜料(包塑)產品常用為黑白兩色, 有圓型扁型, 其他可顏色定 PVC coated product normal color white and black, other color have extra charge	
	HT-0.55	2.2	1.2	300克	約80米			
	HT-0.75	2.4	1.3	300克	約58米			
	HT-0.9	-	1.5	300克	約42米			
	HT-1.2	-	1.8	定制重量	定制長度			-
	HT-1.5	-	2.2	定制重量	定制長度			-

備註: 長度僅供參考, 實際長度以收到的實物為準。產品紮線直徑指的是裏面鐵絲的直徑
 For Reference Only, The Actual Length Is Subject To The Real Product.

品名 PRODUCT NAME	長度(CM) LENGTH	數量(根) NUMBER	備註 REMARKS
鍍鋅鐵絲 紮線 Galvanized wire line cutting Wire	6cm、8cm、10cm、12cm、15cm 20cm、25cm、30cm	1000\包	裁斷絲內芯鐵絲是0.55, 分圓型/扁型, 常用色為黑白兩色如需其他顏色或長度可定制 Cutting Wire inner core 0.55 Product normal color white and black, other color have extra charge

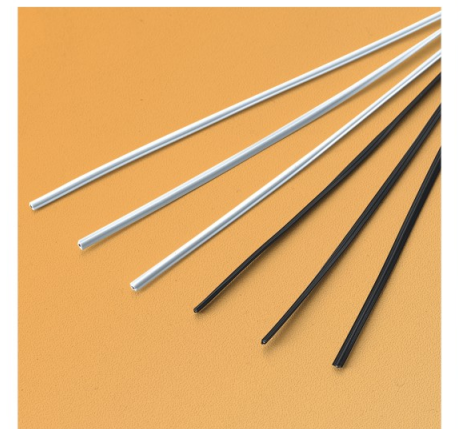

塑料十字架 PLASTIC CROSS

型號 ITEM NO.	A(mm)	B(mm)	A(mm)	B(mm)
2	27	27	3	2
3	31	31	3	3
5	34	34	6	5
7	44	44	7	7
8	44	44	8	8
10	49	49	10	10

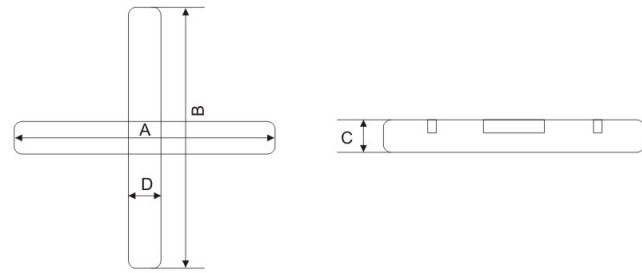

尼龍安全型壓線帽HT-(Φ3-Φ8)

NYLON CLOSE-END WIRING CONNECTOR HT-(Φ3-Φ8)

材質：內部套管由銅度銀制成，外部採用UL認證之尼龍66料或聚乙烯制成。

使用方法：將電線外皮剝去插入套管內，用壓線鉗壓緊即可。

用途：電器制品之優良接線器。

Material: Silver-coated copper piece covered by UL. Appoved Nylon or PE.

How to use: put in the bare wire end into the cap and press wit clipper.

Application: Wire joining.

型號 ITEM NO.	HT- 尼龍 Φ3	HT- 尼龍 Φ4	HT- 尼龍 Φ5	HT- 尼龍 Φ6	HT- 尼龍 Φ8
標準尺寸 Standard size	Φ1	3	3.15	3.66	4.66
	Φ2	7.3	8	8.5	10
	Φ3	9	9.75	10.5	12
	L ₁	19.5	20.4	22.5	25.2
	L ₂	6.5	6.5	7.5	7.8

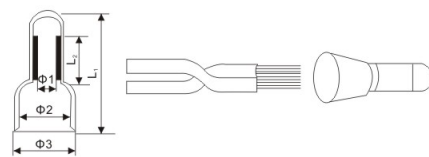

尼龍電纜固定頭 NYLON CABLE GLAND

材料：採用UL認可的尼龍材料

密封蓋：丁晴橡膠(NBR), 耐候橡膠(EPDM)

工作溫度：靜態-40℃至100℃
或瞬間可耐熱至120℃
動態-20℃至80℃
或瞬間可耐熱至100℃

防護等級：IP68

顏色種類：灰色, 黑色, 其它顏色可定做

Material: PA (NYLON), UL 94

Hermetic seal: NBR, EPDM

Working temperature: -40℃ to 100℃ in static state

Instantaneous heat resistance up to 120℃

-20℃ to 80℃ in dynamic state

Instantaneous heat resistance up to 100℃

Degree of Protection: IP68-10

Color: Grey, Black, other colors customized.

型號 ITEM NO.	Thread	Ø (mm)	H (mm)	GL (mm)	Ø (mm)
HT-7	PG 7	3-6.5	21	8	15
HT-7	PG 7	2-5	21	8	15
HT-9	PG 9	4-8	21	8	19
HT-9	PG 9	2-6	22	8	19
HT-11	PG 11	5-10	25	8	22
HT-11	PG 11	3-7	25	8	22
HT-13.5	PG 13,5	6-12	27	9	24
HT-13.5	PG 13,5	5-9	27	9	24
HT-16	PG 16	10-14	28	10	27
HT-16	PG 16	7-12	28	10	27
HT-21	PG 21	13-18	31	11	33
HT-21	PG 21	9-16	31	11	33
HT-29	PG 29	18-25	39	11	42
HT-29	PG 29	13-20	39	11	42
HT-36	PG 36	22-32	48	13	53
HT-36	PG 36	20-26	48	13	53
HT-42	PG 42	32-38	49	13	60
HT-42	PG 42	25-31	49	13	60
HT-48	PG 48	37-44	49	14	65
HT-48	PG 48	29-35	49	14	65

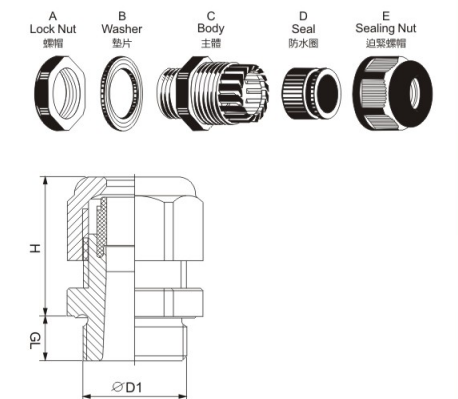

金屬電纜固定頭 METAL CABLE GLAND

材料：鍍鎳黃銅

固定連接組件：採用UL認可的尼龍材料

密封蓋：丁晴橡膠(NBR), 耐候橡膠(EPDM)

防護等級：IP68-10

工作溫度：-40℃至100℃
或瞬間可耐熱至120℃

Material: Nickel-plated brass

Fixture pack: PA (NYLON), UL 94

Hermetic seal: NBR, EPDM

Protection degree: IP68-10

Working temperature: -40℃ to 100℃

Instantaneous heat resistance up to 120℃

型號 ITEM NO.	Thread	Ø (mm)	H (mm)	GL (mm)	Ø (mm)
HT-7	PG 7	3-6.5	19	5	14
HT-7	PG 7	2-5	19	5	14
HT-9	PG 9	4-8	21	6	17
HT-9	PG 9	2-6	21	6	17
HT-11	PG 11	5-10	22	6	20
HT-11	PG 11	3-7	22	6	20
HT-13.5	PG 13,5	6-12	24	6,5	22
HT-13.5	PG 13,5	5-9	24	6,5	22
HT-16	PG 16	10-14	23	6,5	24
HT-16	PG 16	7-12	23	6,5	24
HT-21	PG 21	13-18	24	7	30
HT-21	PG 21	9-16	24	7	30
HT-29	PG 29	18-25	29	8	40
HT-29	PG 29	13-20	29	8	40
HT-36	PG 36	22-32	35	8	50
HT-36	PG 36	20-26	35	8	50
HT-42	PG 42	32-38	37	9	57
HT-42	PG 42	25-31	37	9	57
HT-48	PG 48	37-44	38	10	64
HT-48	PG 48	29-35	38	10	64

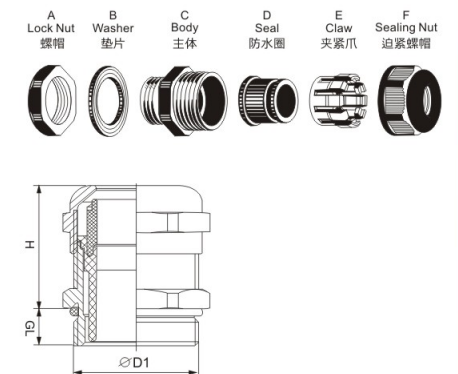



彈簧螺式接線頭 WIRE CONNECTORS

材質：採用PVC制成，內有螺紋，耐熱、絕緣。

使用方法：將電線外皮剝去部分，將所要接的電線，同時插入扭緊即可。

用途：電器制品之優良接線器。

Material: PVC, threaded, Heat-resistant and insulating.

How to use: Put the joint of two wires into the cap and screw it in until it is tight. wall to secure the cable.

Application: Wire joining.

型號 ITEM NO.	高H (mm)	寬B (mm)	螺紋內徑C (mm)	適用電線圍 Approx Wire Size	包裝 Std.PKg.
HT-P1	15.0	9.0	7.0	0.5-1.0mm ² (AWG22-18)	100PCS及 1000PCS
HT-P2	18.0	10.0	8.0	1.0-1.5mm ² (AWG18-16)	
HT-P3	23.0	11.0	10.0	1.5-2.5mm ² (AWG16-14)	100PCS及 500PCS
HT-P4	24.0	14.0	11.0	2.5-4mm ² (AWG14-12)	
HT-P5	28.0	16.0	13.0	4-6mm ² (AWG12-10)	100PCS及 500PCS
HT-P6	32.0	18.0	14.0	10-16mm ² (AWG 6)	



彈簧螺式接線頭 SCREW ON WIRE CONNECTOR

材料：UL尼龍66，內有彈簧。

使用方法：剝開電線外套，插入電線，然後擰緊。

Material: UL nylon66, with spring inside.

Usage: Peel wire coat, insert the wire in, then tighten.

型號 ITEM NO.	高H (mm)	寬B (mm)	螺紋內徑C (mm)	適用電線圍 Approx Wire Size	包裝 Std.PKg.
HT-P7	25.0	18.0	9.0	4-6mm ² (AWG12-10)	100PCS及 500PCS
HT-P8	29.0	22.0	11.0	6-12mm ² (AWG8-6)	

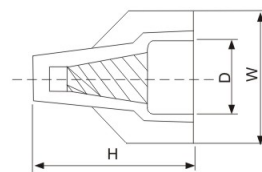

雙翼彈簧螺式接線頭 DOUBLE WINGS SCREW ON WIRE CONNECTORS

材料：UL尼龍66，內有彈簧。

使用方法：剝開電線外套，插入電線，然後擰緊。

Material: UL nylon66, with spring inside.

Usage: Peel wire coat, insert the wire in, then tighten.

型號 ITEM NO.	高H (mm)	寬B (mm)	螺紋內徑C (mm)	適用電線圍 Approx Wire Size	顏色 Color
HT-P9	25.4	18.0	9.5	0.5-2.5mm ² (AWG22-14)	Yellow
HT-P10	27.7	17.8	10.0	0.5-4mm ² (AWG22-12)	Taupe
HT-P11	30.5	23.1	12.0	1.0-6mm ² (AWG18-10)	Red
HT-P12	32.6	25.5	14.6	1.0-10mm ² (AWG18-8)	Grey
HT-P13	39.5	31.7	17.8	2.5-16mm ² (AWG14-6)	Blue

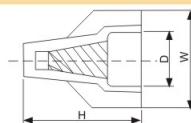

H系列接線端子 H TYPE TERMINAL BLOCK (12 POLE)

材質 Material:

插片：黃銅 Insert: brass

塑料：PE, PP或PA

Plastic: PE, PP or PA

顏色：本色，黑色，白色

Color: Natural, Black, White

技術參數 Technical Data:

最大工作溫度

Max. Operating temperature: -5℃~+85℃ for PE

符合標準According to: EN60998-1 EN60998-2-1

型號 Item No.	額定電流 Rated current(A)	導線截面積 Section size (mm ²)	尺寸 Dimension (mm)					
			L (mm)	W (mm)	H (mm)	A (mm)	B (mm)	Ød (mm)
H-3	3	2.5/4	92	15.5	12.7	5.5	8.0	3.0
H-6	6	6	119	17.3	13.9	6.5	8.2	3.3
H-10	10	10	131	20.85	16.4	7.25	11.2	3.71
H-15	15	12	135	22.65	18.25	8.25	11.5	4.2
H-20	20	14	141.6	22.65	18.4	8.5	12.2	4.5
H-30	30	16	165	24.1	21.1	9.5	14.1	5.5
H-60	60	25	190	30.8	25.2	11.15	16.5	6.3
H-80	80	30	201	36	22.65	12.1	18.15	6.9
H-100	100	35	228	38	33	13.8	19.4	7.4
H-150	150	40	261	44	33	21.2	22	8.3

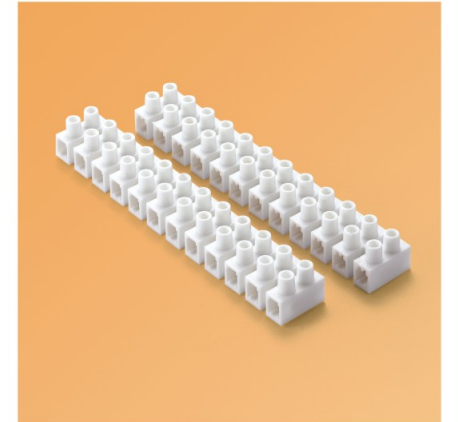
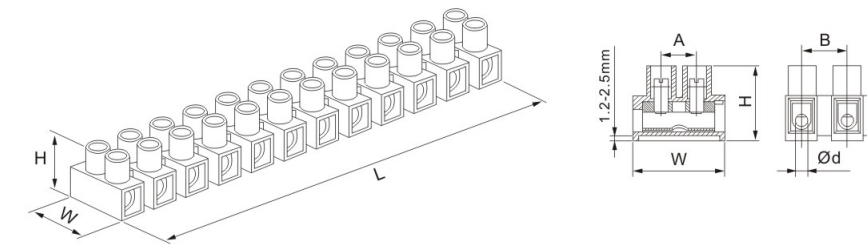

H-E系列接線端子 H-E TYPE TERMINAL BLOCK

材質 Material:

插片：黃銅 Insert: brass

塑料：PE, PP或PA

Plastic: PE, PP or PA

顏色：本色，白色

Color: Natural, White

技術參數 Technical Data:

最大工作溫度

Max. Operating temperature: -30℃~+110℃ for PA

符合標準According to: EN60998-1 EN60998-2-1

型號 Item No.	額定電流 Rated current(A)	導線截面積 Section size (mm ²)	尺寸 Dimension (mm)					
			L (mm)	W (mm)	H (mm)	A (mm)	B (mm)	Ød (mm)
H-E8	17.5	1.5	95.37	16.9	15.05	6.3	8.2	2.9
H-E10	24	2.5	117	20.5	16.8	9.6	10.1	3.2
H-E12	41	6	140.1	23.9	18.8	10	12.2	4.2
H-E14	57	10	158	25.7	25.15	10.75	13.6	5

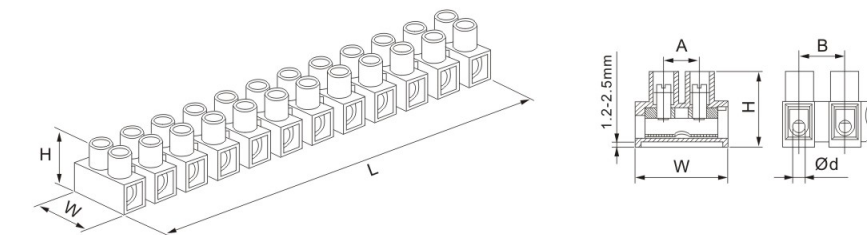

F(V)系列接線端子 F(V) TYPE TERMINAL BLOCK (12 POLE)

材質 Material: PA, PE or PP

顏色: 本色, 黑色, 白色 Color: Natural, Black, White



型號 Item No.	額定電流 Rated current(A)	導線截面積 Section size (mm ²)	尺寸 Dimension (mm)					
			L (mm)	W (mm)	H (mm)	A (mm)	B (mm)	Ød (mm)
F-3	3	2.5/4	91.25	15.7	13.5	5.7	8	3.2
F-5	5	6	109.35	16.9	14.5	6.5	9.21	3.3
F-10	10	10	126.2	20.25	15.8	8.25	10.6	3.85
F-15	15	12	135	22.6	17.6	8.3	11.9	4.3
F-30	30	16	156	25.65	20.5	9.1	13.1	5.5
F-60	60	25	189	29.9	25.6	13.0	15.8	6.6
F-80	80	30	205	36.1	29.9	14.2	17.2	7.3

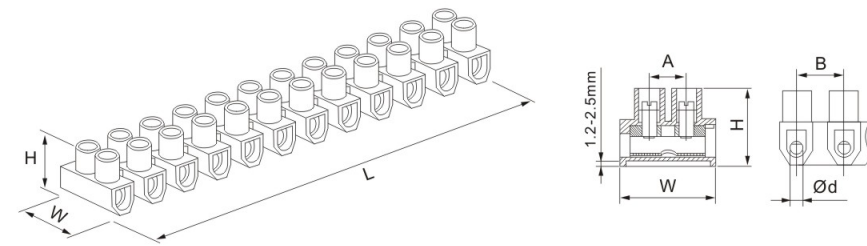

W(U)系列接線端子 W(U) TYPE TERMINAL BLOCK (12 POLE)

材質 Material: PA, PE or PP

顏色: 本色, 黑色, 白色 Color: Natural, Black, White



型號 Item No.	額定電流 Rated current(A)	導線截面積 Section size (mm ²)	尺寸 Dimension (mm)					
			L (mm)	W (mm)	H (mm)	A (mm)	B (mm)	Ød (mm)
W-3	3	2.5/4	92	14.9	11.70	4.1	8	3.0
W-6	6	6	110	16.5	12.85	6.6	9.6	3.3
W-10	10	10	127.7	19.35	15.4	7.1	11.1	3.71
W-15	15	12	134	22.3	17.2	8.3	11.5	4.2
W-20	20	14	144	22.5	17.4	8.65	12.2	4.5
W-30	30	16	163	24.9	19	9.1	14.1	5.5
W-60	60	25	187	28.65	21.4	11.2	16	6.3
W-80	80	30	208	35.8	29.15	12.2	18	7.4

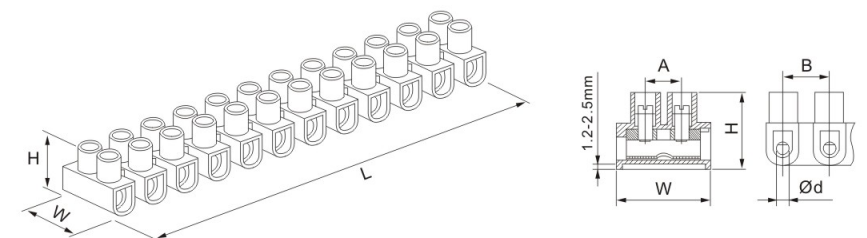

H-1包裝尺寸 PACKING DETAILS H-1

U TYPE PACKING

型號 ITEM NO.	裝袋數量 PCS/BAG	裝箱數量 PCS/CTN	外箱尺寸 CM	毛/淨重 KG
3A-4mm	10	1500	41 × 29 × 27	26/25
5A-6mm	10	1200	48 × 24 × 29	26/25
6A-6mm	10	100	48 × 22 × 30	24/23
10A-10mm	10	800	42 × 27 × 30	26/25
15A-12mm	10	500	39 × 29 × 27	25/24
20A-14mm	10	500	37 × 28 × 27	26/25
30A-20mm	10	300	39.5 × 35.5 × 22	22/21
60A-25mm	10	200	39 × 31 × 28	24/23
80A-30mm	5	120	39 × 21.5 × 38	26/24
100A-40mm	5	50	54 × 25 × 20	18/17

H TYPE PACKING

型號 ITEM NO.	裝袋數量 PCS/BAG	裝箱數量 PCS/CTN	外箱尺寸 CM	毛/淨重 KG
3A-4mm	10	1500	41 × 29 × 27	26/25
5A-6mm	10	1200	48 × 28 × 34	25/24
6A-6mm	10	100	47 × 24 × 30	25/24
10A-10mm	10	800	39 × 25 × 36	23/22
15A-12mm	10	500	36 × 28 × 37	27/26
20A-14mm	10	500	40 × 30 × 33	27/26
30A-20mm	10	300	37 × 34 × 23	23/22
60A-25mm	10	200	40 × 31 × 26	25/24
80A-30mm	5	120	39 × 31 × 26	26/24



H-1



H-2



H-3



H-4



ECM型配線標志 ECM-TYPE WIRE MARKERS

材質: 採用較質PVC料精制,形如倒凹形,套管上面印有文字代號,內徑伸縮彈性很大。

使用方法: 使用時將每個切離處輕剝下,即可配線。

特點: 各種型號適合各種大小之配線,接受配線長度或特殊標誌之訂制。

Material: Soft PVC, concave conversed shape, no.code in sleeve,elasticity of in-diameter.

How to use: Peel each hack lightly

Feature: Suitable any size, special length and marking is available to order.

型號 ITEM NO	適用電線 SUITABLE WIRE	內徑 IN-DIAMETER	長度 LENGTH	號碼 No.	包裝 PACKING
GEC-0	18AWG 16AWG 0.75	2.0-3.0	3.5	A-Z +, -, ÷	1000PCS
GEC-1	0.75 1.25 2.0 3.0	3.0-5.2	4.0		1000PCS
GEC-2	3.5 5.5 8.0	3.6-7.4	5.0		500PCS
GEC-3	8.0 14.0 22.0	5.2-10.0	5.0		250PCS



連接片 CARRIER MARKER STRIPS

材質: 採用UL認可之尼龍PA66料制成,防火等級94V-2,絕緣好良好,耐久性不易老化。

構造: 為長方條型,兩端各有兩個帶孔。

Material: Nylon PA66,94-2 certificated by UL. Insulate well and not apt to age.

Construction: In order to rectangular bar, both ends of each hole.

型號 ITEM NO.		長度 LENGTH	包裝 PACKING
白色(White)	黑色(White)		
MS-65	MS-65	65	100PCS
MS-100	MS-100	100	
MS-135	MS-135	135	

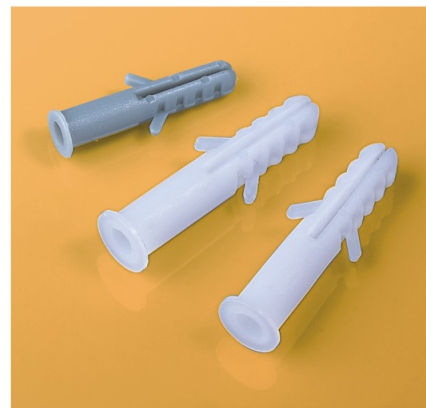
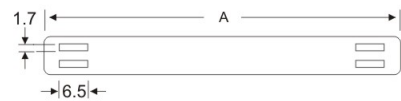

HT膨脹管 EXPAND NAILS

材質: 採用PE料制成

Material: made from PE.

顏色: 白、灰

Color: White, Grey

編號 ITEM.NO.	長 L (mm)	外徑 D (mm)	內徑 D (mm)	螺絲釘 (mm)	包裝 PACKING
EN-05	-	5.0	-	-	100PCS
EN-06	29.8	6.0	4.9	φ4x32	
EN-07	29.8	7.0	5.3	φ5x32	
EN-08	38.6	7.9	5.3	φ5x40	
EN-10	42.7	9.9	5.8	φ5x45	
EN-12	47.9	11.6	6.3	φ6x50	
EN-14	-	-	-	-	

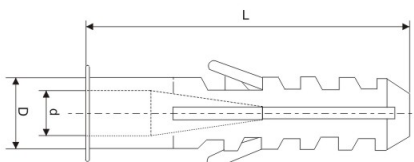

宏泰環保阻燃縫槽 Wide Slot Wiring Duct

產品材質: 採用低鹵素硬質PVC料制成,環保無汙染,不含鉛等有毒物。

產品認證: 歐洲CE 歐洲環保RoHS,REACH, 鐵道阻燃低煙。

防火等級: UL94V-0, 低煙微鹵, 遇火不燃燒, 防火性及絕緣性特佳。

產品構造: 由槽底及槽蓋組成, 底槽兩側設有出線孔。

顏色: 灰色, 白色, 藍色, 黑色 (可定制其它顏色, 有起訂量要求)

工作溫度: 靜態-40℃持續高溫至65℃, 短時間可達85℃。

使用方法: 先將底槽固定, 將所要配的線裝入槽內, 蓋上槽蓋即可。

產品特性: 1.反扣式槽蓋與槽體設計組合後絕不脫落, 且接合面平滑, 不割傷手及擦損附近配線。

2.配線槽65℃內不易斷裂, 變形, 變色, 裝配省時便利。

3.出線孔低、組合容易、拆卸簡單、易於配線。

更多選擇: 量大可按需求生產所需規格或定制長度。例: VDR8080F (L=1.7M)

Wide slot/finger design provides greater sidewall rigidity and can be used with a wide range of wire bundle sizes.

Certificates: CE:EN50085 RoHS,REACH. Made of rigid PVC

Work temperature: -40℃ to 65℃

UI94 Flammability Rating of V-0

Provided with mounting holes

Available color: gray. white. blue. black and other special colors

Special length come with MOQ request

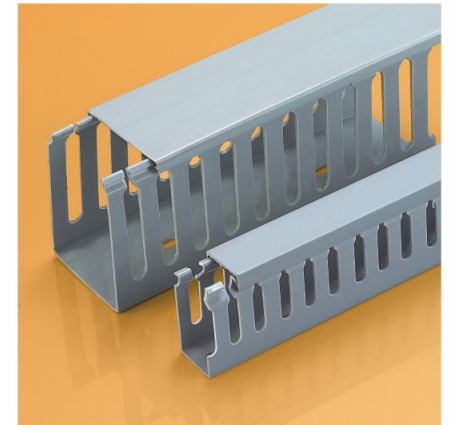

型號 Type	高×寬 H×W(mm)	電線容量 Contained wire (2.0 ²)	長度 Length
PXC3-20/15	20×15	5-10 PCS	2m
PXC3-20/25	20×25	5-15 PCS	2m
PXC3-25/25	25×25	10-20 PCS	2m
PXC3-30/15	30×15	5-15 PCS	2m
PXC3-30/20	30×20	10-20 PCS	2m
PXC3-30/25	30×25	15-25 PCS	2m
PXC3-30/30	30×30	20-40 PCS	2m
PXC3-30/35	30×35	30-45 PCS	2m
PXC3-35/30	35×30	30-45 PCS	2m
PXC3-35/35	35×35	35-50 PCS	2m
PXC3-35/40	35×40	50-60 PCS	2m
PXC3-40/25	40×25	20-25 PCS	2m
PXC3-40/30	40×30	35-45 PCS	2m
PXC3-40/40	40×40	60-70 PCS	2m
PXC3-50/15	50×15	10-25 PCS	2m
PXC3-50/25	50×25	25-45 PCS	2m
PXC3-50/30	50×30	30-50 PCS	2m
PXC3-50/35	50×35	50-60 PCS	2m
PXC3-50/40	50×40	60-70 PCS	2m
PXC3-50/45	50×45	70-80 PCS	2m
PXC3-50/50	50×50	80-90 PCS	2m
PXC3-50/55	50×55	100-110 PCS	2m
PXC3-50/80	50×80	180-200 PCS	2m
PXC3-50/100	50×100	210-260 PCS	2m
PXC3-80/45	80×45	160-180 PCS	2m
PXC3-80/50	80×50	180-200 PCS	2m
PXC3-80/55	80×55	180-210 PCS	2m
PXC3-80/80	80×80	240-290 PCS	2m
PXC3-80/100	80×100	260-350 PCS	2m
PXC3-100/100	100×100	300-400 PCS	2m

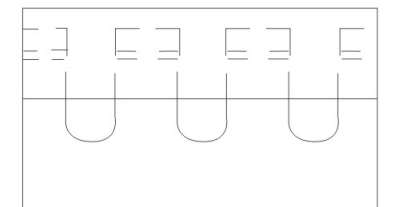
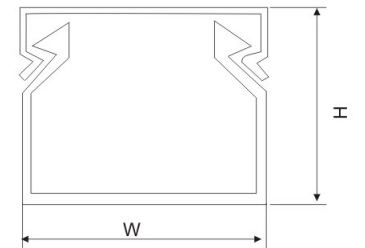

PEC系列建築裝璜線槽

ARCHITECTURE & DECORATING WIRE DUCT

材質: 南亞硬質PVC(白色), 絕緣性良好、不自燃、耐溫至85℃。
構造: 由槽底及槽蓋兩部分組成。
用途: 舞台、電氣、冷氣工程及室內明線配線等適用。
特點: 密封式絕緣配線槽專為防塵、防鼠而設計。

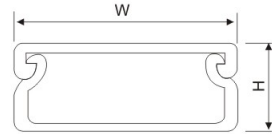

Material: Made from PVC (white), good insulation, nonpyrophoricity and heat-resisting up to 85℃.
Structure: Made up of duct bottom and lid.
Application: Suitable for open wire's distributing of stage, electric, cold air engineering and indoors.
Character: Sealed insulating distributing slot is designed special for dust proof and mouse proof.

型號 Type	高×寬 H×W(mm)	電線容量 Contained wire (2.0 ²)	長度 Length
PEC-1015	10×15	2-5 PCS	2m
PEC-1020	10×20	3-6 PCS	2m
PEC-1025	10×25	5-10 PCS	2m
PEC-1035	10×35	10-15 PCS	2m
PEC-1525	15×25	5-10 PCS	2m
PEC-1530	15×30	5-15 PCS	2m
PEC-2030	20×30	10-20 PCS	2m
PEC-2035	20×35	15-25 PCS	2m
PEC-2050	20×50	20-25 PCS	2m
PEC-2540	25×40	20-40 PCS	2m
PEC-3045	30×45	25-45 PCS	2m
PEC-3050	30×50	30-50 PCS	2m
PEC-3060	30×60	55-65 PCS	2m
PEC-3080	30×80	75-85 PCS	2m
PEC-30100	30×100	130-150 PCS	2m
PEC-5015	50×15	10-25 PCS	2m
PEC-5025	50×25	25-45 PCS	2m
PEC-5035	50×35	50-60 PCS	2m
PEC-5045	50×45	70-80 PCS	2m
PEC-5050	50×50	80-90 PCS	2m
PEC-5055	50×55	100-110 PCS	2m
PEC-5080	50×80	180-200 PCS	2m
PEC-8045	80×45	160-180 PCS	2m
PEC-8050	80×50	180-200 PCS	2m
PEC-8055	80×55	180-210 PCS	2m
PEC-8080	80×80	240-290 PCS	2m
PEC-80100	80×100	260-350 PCS	2m
PEC-50100	50×100	200-260 PCS	2m
PEC-50120	50×120	240-290 PCS	2m
PEC-80120	80×120	300-400 PCS	2m
PEC-100160	100×160	450-600 PCS	2m
PEC-160200	160×200	1040-1200 PCS	2m

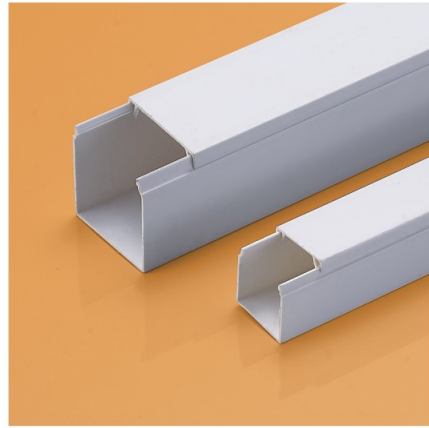

FIVE

electrical connector series

接綫端子系列



叉形預絕緣端子 FURCATE PRE-INSULATING TERMINAL

導線截面: 0.5~1.5mm² (美國線規 22~16) 最大電流: I_{max}=19A

Size of cable: 0.5~1.5mm² (American standar 22~16) Max. Current=19A

型號 ITEM NO	美制螺絲號 U.S. standard screw bolt	尺寸 DIMENSION						顏色 color
		螺絲口直徑 diameter D2(mm)	B mm	L mm	F mm	H mm	DΦ mm	
SV 1.25-3.2	# 4	3.2	5.7	21.2	6.5	10.0	4.3	紅 red
SV 1.25-3.7S	# 6	3.7	5.7	21.2	6.5			
SV 1.25-3.7L	# 6	3.7	6.4	21.2	6.5			
SV 1.25-4S	# 8	4.3	6.4	21.2	6.5			
SV 1.25-4M	# 8	4.3	7.2	21.2	6.5			
SV 1.25-4L	# 8	4.3	8.1	21.2	6.5			
SV 1.25-5S	# 10	5.3	8.1	21.2	6.5			
SV 1.25-5L	# 10	5.3	9.5	21.2	6.5			
SV 1.25-6S	1/4	6.5	9.5	21.2	6.5			
SV 1.25-6L	1/4	6.5	12.0	27.2	11.0			



導線截面: 1.5~2.5mm² (美國線規 16~14) 最大電流: I_{max}=27A

Size of cable: 1.5~2.5mm² (American standard 16~14) Max. Current=27A

型號 ITEM NO	美制螺絲號 U.S. standard screw bolt	尺寸 DIMENSION						顏色 color
		螺絲口直徑 diameter D2(mm)	B mm	L mm	F mm	H mm	DΦ mm	
SV 2-3.2	# 4	3.2	5.7	21.2	6.5	10.0	4.9	蘭 blue
SV 2-3.7S	# 6	3.7	5.7	21.2	6.5			
SV 2-3.7L	# 6	3.7	6.0	21.2	6.5			
SV 2-4S	# 8	4.3	6.4	21.2	6.5			
SV 2-4M	# 8	4.3	7.2	21.2	6.5			
SV 2-4L	# 8	4.3	8.1	21.2	6.5			
SV 2-5S	# 10	5.3	8.1	21.2	6.5			
SV 2-5L	# 10	5.3	9.5	21.2	6.5			
SV 2-6S	1/4	6.5	9.5	21.2	6.5			
SV 2-6L	1/4	6.5	12.0	27.2	11.0			



導線截面: 2.5~4mm² (美國線規 14~12) 最大電流: I_{max}=37A

Size of cable: 2.5~4mm² (American standard 14~12) Max. Current=37A

型號 ITEM NO	美制螺絲號 U.S. standard screw bolt	尺寸 DIMENSION						顏色 color
		螺絲口直徑 diameter D2(mm)	B mm	L mm	F mm	H mm	DΦ mm	
SV 3.5-4	# 8	4.3	8.0	24.8	7.0	12.5	6.2	黑 black
SV 3.5-5	# 10	5.3	8.0	24.8	7.0			
SV 3.5-5L	# 10	5.3	12.0	27.9	7.7			
SV 3.5-6	1/4	6.5	12.0	28.0	12.1			

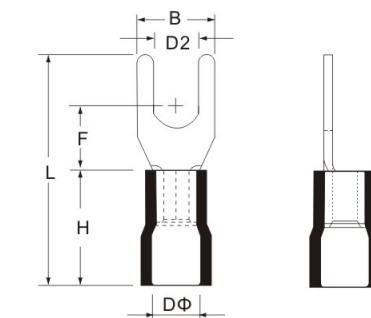

導線截面: 4~6mm² (美國線規 12~10) 最大電流: I_{max}=48A

Size of cable: 4~6mm² (American standard 12~10) Max. Current=48A

型號 ITEM NO	美制螺絲號 U.S. standard screw bolt	尺寸 DIMENSION						顏色 color
		螺絲口直徑 diameter D2(mm)	B mm	L mm	F mm	H mm	DΦ mm	
SV 5.5-3.5	# 6	3.7	8.3	25.2	7.5	12.5	6.7	黃 yellow
SV 5.5-4S	# 8	4.3	8.3	25.2	7.5			
SV 5.5-4L	# 8	4.3	9.0	23.9	7.5			
SV 5.5-5	# 10	5.3	9.0	23.9	7.5			
SV 5.5-6S	1/4	6.5	9.0	23.9	7.5			
SV 5.5-6L	1/4	6.5	12.0	31.2	12.0			
SV 5.5-8	5/16	8.4	14.0	30.0	11.5			

圓形預絕緣端子 CIRCULAR PRE-INSULATING TERMINAL

導線截面: 0.5~1.5mm² (美國線規 22~16) 最大電流: I_{max}=19A

Size of cable: 0.5~1.5mm² (American standar 22~16) Max. Current=19A

型號 ITEM NO	美制螺絲號 U.S. standard screw bolt	尺寸 DIMENSION						顏色 color
		螺絲口直徑 diameter D2(mm)	B mm	L mm	F mm	H mm	DΦ mm	
RV 1.25-3.2	# 4	3.2	5.7	17.8	4.95	10.0	4.3	紅 red
RV 1.25-3.7S	# 6	3.7	5.7	17.8	4.95			
RV 1.25-3.7M	# 6	3.7	6.6	20.1	6.3			
RV 1.25-3.7L	# 6	3.7	8.0	21.5	7.0			
RV 1.25-4S	# 8	4.3	6.6	20.1	6.3			
RV 1.25-4L	# 8	4.3	8.0	21.5	7.0			
RV 1.25-5	# 10	5.3	8.0	21.5	7.0			
RV 1.25-6	1/4	6.5	11.6	27.5	11.1			
RV 1.25-8	5/16	8.4	11.6	27.5	11.1			
RV 1.25-10	3/8	10.5	13.6	31.6	13.9			



導線截面: 1.5~2.5mm² (美國線規 16~14) 最大電流: I_{max}=27A

Size of cable: 1.5~2.5mm² (American standar 16~14) Max. Current=27A

型號 ITEM NO	美制螺絲號 U.S. standard screw bolt	尺寸 DIMENSION						顏色 color
		螺絲口直徑 diameter D2(mm)	B mm	L mm	F mm	H mm	DΦ mm	
RV 2-3.2	# 4	3.2	6.6	17.8	4.3	10.0	4.9	蘭 blue
RV 2-3.7S	# 6	3.7	6.6	17.8	4.3			
RV 2-3.7M	# 6	3.7	6.6	21.0	7.0			
RV 2-3.7L	# 6	3.7	8.5	22.5	7.75			
RV 2-4S	# 8	4.3	6.6	21.0	7.0			
RV 2-4L	# 8	4.3	8.5	22.5	7.75			
RV 2-5S	# 10	5.3	8.5	22.5	7.75			
RV 2-5L	# 10	5.3	9.5	22.5	7.25			
RV 2-6	1/4	6.5	12.0	27.6	11.0			
RV 2-8	5/16	8.4	12.0	27.6	11.0			
RV 2-10	3/8	10.5	13.6	30.2	13.9			



導線截面: 2.5~4mm² (美國線規 14~12) 最大電流: I_{max}=37A

Size of cable: 2.5~4mm² (American standard 14~12) Max. Current=37A

型號 ITEM NO	美制螺絲號 U.S. standard screw bolt	尺寸 DIMENSION						顏色 color
		螺絲口直徑 diameter D2(mm)	B mm	L mm	F mm	H mm	DΦ mm	
RV 3.5-4	# 8	4.3	8.0	24.5	7.7	12.5	6.2	黑 black
RV 3.5-5S	# 10	5.3	8.0	24.5	7.7			
RV 3.5-5L	# 10	5.3	12.0	27.9	7.7			
RV 3.5-6	1/4	6.5	12.0	27.9	7.7			

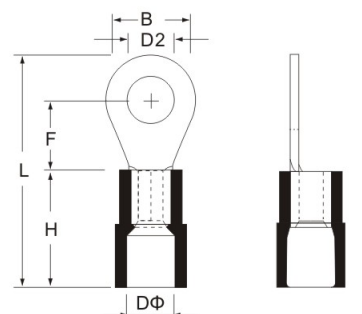

導線截面: 4~6mm² (美國線規 12~10) 最大電流: I_{max}=48A

Size of cable: 4~6mm² (American standard 12~10) Max. Current=48A

型號 ITEM NO	美制螺絲號 U.S. standard screw bolt	尺寸 DIMENSION						顏色 color
		螺絲口直徑 diameter D2(mm)	B mm	L mm	F mm	H mm	DΦ mm	
RV 5.5-3.7	# 6	3.7	7.2	21.4	5.9	12.5	6.7	黃 yellow
RV 5.5-4	# 8	4.3	7.2	21.4	5.9			
RV 5.5-4	# 8	4.3	9.5	25.5	8.3			
RV 5.5-5	# 10	5.3	9.5	25.5	8.3			
RV 5.5-6	1/4	6.5	12.0	31.5	13.0			
RV 5.5-8	5/16	8.4	15.0	33.7	13.7			
RV 5.5-10	3/8	10.5	15.0	33.7	13.7			
RV 5.5-12	1/2	13.0	19.2	38.1	16.0			



長、短形全絕緣中間接頭
Long, Short Full Insulating Middle Joint



公預絕緣接頭
Insulated male Terminals



母預絕緣接頭
Insulated Female Terminals



母全絕緣接頭
Female Insulated Connectors



尼龍公全絕緣接頭
Insulated Nylon male Connectors



尼龍母全絕緣接頭
Insulated Nylon Female Connectors



快速連接接頭
Fast Wiring Connectors



肩背形公母預絕緣接頭
Piggyback Connectors



絕緣軟套管
Insulated Teleflex

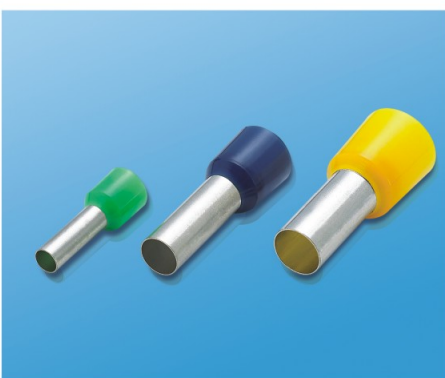

管形預絕緣端頭
Insulated Core End Terminals

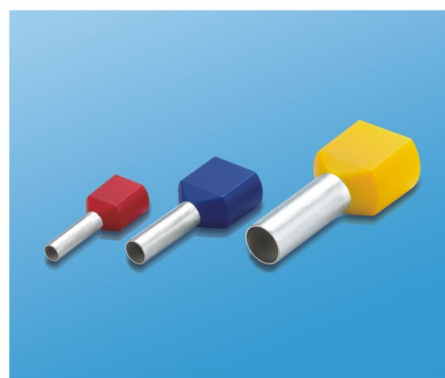

雙線管形預絕緣端頭(TG-JT型)
Crewel tube pre-insulating terminal (Type TG-JT)

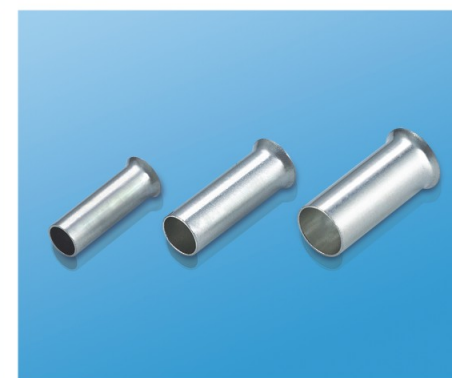

管形裸端頭(TG型)
Tube Naked Terminal (Type TG)

包裝款式系列 PACKING OF SERIES

ITEM NO.	E1	
DETAIL	FDFD1-250	3
	FDFD2-250	3
	FDFD5-250	3
	BV1	5
	BV2	3
	BV5	8
MEAS	50×50×42CM	
QTY	240SETS/CTN	
G.W/N.W	13/12kgs	



ITEM NO.	E2			
DETAIL	MDD1-250	5	RV2-5	5
	MDD2-250	5	RV2-4	5
	FDD1-250	5	Bv1	5
	FDD2-250	5	BV2	4
	RV1.25-3	5	SV2-5	5
	RV2-3	5	RV1.25-5	5
	SV1.25-4	4	BV5	5
	RV2-4	4	RV5.5-5	4
	RV1.25-5	5	RV5.5-6	4
	MEAS	53×29×45CM		
QTY	60SETS/CTN			
G.W/N.W	7.5/6.5kgs			



ITEM NO.	E3		
DETAIL	RV125-3.2	10	
	SV125-3.7	10	
	RV125-5	8	
	SV125-4	8	
	RV5.5-5	5	
	SV5.5-5	5	
	FDD1-250	8	
	MDD1-250	8	
	FDD2-250	8	
	MDD2-250	8	
	BV1	6	
	BV2	6	
	MEAS	42×36×32CM	
	QTY	120SETS/CTN	
	G.W/N.W	23/22kgs	



包裝款式系列 PACKING OF SERIES



ITEM NO .	E4			
DETAIL	RV1.25-3.7	10	MDD1-250	10
	RV1.25-5	10	SV2-5	10
	FDD2-250	10	BV2	8
	FDD1-250	10	SV1.25-3	10
	RV2-5	10	RV1.25-5	10
	BV1	10	RV2-4	10
	RV2-3.7	10	RV5.5-5	5
	SV1.25-5	10	RV5.5-6	5
	MDD2-250	10	BV5	5
MEAS	58×46×36CM			
QTY	80SETS/CTN			
G.W/N.W	23/22kgs			

ITEM NO .	E5	
DETAIL	SV2-4	10
	SV2-5	10
	RV2-5	10
	RV125-3.7	15
	RV125-5	15
	RV125-5	15
	BV1	5
	BV2	5
	FDD1.25-250	10
	FDD2-250	10
	RV5.5-5	5
SV5.5-5	5	
MEAS	58×47×37CM	
QTY	80SETS/CTN	
G.W/N.W	22/21kgs	

ITEM NO .	E6	
DETAIL	FDFD1-250	5
	FDFD2-250	5
	BV1	10
	BV2	10
	FDD1-250	10
	FDD2-250	10
	MDD1-250	10
	MDD2-250	10
	RV5.5-6	5
	RV5.5-5	5
	RV2-5	10
	SV125-5	10
	MEAS	48×48×50CM
QTY	160SETS/CTN	
G.W/N.W	29/28kgs	



包裝款式系列 PACKING OF SERIES

ITEM NO .	1#		
DETAIL	E0508	100	White
	E7508	100	Bule
	E1008	100	Red
	E1508	100	Black
	E2508	100	Grey
	E4012	100	Orange
	E6012	50	Green
	E10-12	20	Brown
	MEAS		
QTY			
G.W/N.W			

ITEM NO .	2#			
DETAIL	BV1.25	10	FDFD1.25-250	5
	BV2	10	FDFD2-250	5
	FDD1.25-250	10	RV1.25-5	5
	MDD1.25-250	10	SV2-5	5
	RV5.5-5	5	FDD2-250	10
	RV5.5-6	5	MDD2-250	10
MEAS				
QTY				
G.W/N.W				

ITEM NO .	3#			
DETAIL	RV5.5-6	5	RV2-3	10
	RV5.5-5	5	SV1.25-3.7	10
	BV5.5	5	RV2-5	10
	BV2	10	SV1.25-5	10
	BV1.25	10	FDD1.25-250	10
	SV2-5	10	MDD1.25-250	10
	RV2-5	10	FDD2-250	10
	RV1.25-5	10	MDD2-250	10
	SV1.25-4	10		
	RV1.25-3.7	10		
	MEAS			
QTY				
G.W/N.W				



包裝款式系列 PACKING OF SERIES



ITEM NO.	4#					
DETAIL	E0508	White	100	E25-16	Black	5
	E7508	Bule	100	TE0508	Orange	70
	E1008	Red	80	TE7508	Blue	60
	E1508	Black	80	TE1008	Red	50
	E2508	Grey	60	TE1508	Black	30
	E4009	Orange	40	TE2510	Grey	20
	E6012	Brown	20	TE4012	Orange	10
	E10-12	White	10	TE6014	Green	10
	E16-12	ivory	10	TE10-14	Brown	5
	MEAS					
QTY						
G.W/N.W						



ITEM NO.	5#					
DETAIL	RV2-6		8	SV2-5		8
	BV1.25		5	RV1.25-5		8
	BV2		5	FDD2-250		5
	RV2-5		8	MDD2-250		5
	SV5.5-5		5	FDD1.25-250		5
	RV5.5-6		8	MDD1.25-250		5
	RV5.5-5		8	冷压钳		1
	RV2-3		10			
	MEAS					
	QTY					
G.W/N.W						



ITEM NO.	5#					
DETAIL	RV1.25-3		100	RV5.5-5		30
	RV1.25-4		100	RV5.5-6		30
	RV1.25-5		100	SV2-4		100
	RV1.25-6		50	RV2-4		100
	SV1.25-3		100	FDFD1.25-250		30
	SV1.25-4		100	FDD1.25-250		100
	SV1.25-5		100	MDD1.25-250		100
	SV5.5-5		30	压线钳		1
	MEAS					
	QTY					
G.W/N.W						



ITEM NO.	7#		
DETAIL	0.5mm ²	50	White
	0.75mm ²	100	Grey
	1.0mm ²	100	Red
	1.5mm ²	100	Black
	2.5mm ²	50	Blue
MEAS			
QTY	400PCS		
G.W/N.W			

接線端子系列 TERMINAL BLOCKS SERIES

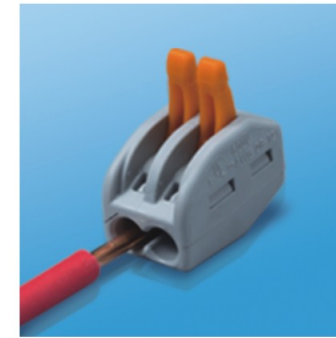

產品型號	LSM2262
適用導線	硬線2.5mm ² /軟線4mm ² (一進一出)
產品規格	20.5x12.4x14.5mm
包裝規格	100個/包
技術參數	額定電壓400V 額定電流32A 額定功率4KW
Model	LSM2262
Wire Range	Hard wire 2.5mm ² / Soft wire 4mm ²
Dimensions	20.5x12.4x14.5mm
Packing	100PCS / bag
Parameters	Rated Voltage 400V Rated Current 32A Rated Power 4KW

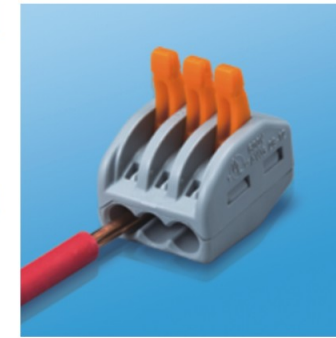

產品型號	LSM2263
適用導線	硬線2.5mm ² /軟線4mm ² (一進二出)
產品規格	20.5x14.5x17mm
包裝規格	100個/包
技術參數	額定電壓400V 額定電流32A 額定功率7KW
Model	LSM2263
Wire Range	Hard wire 2.5mm ² / Soft wire 4mm ²
Dimensions	20.5x14.5x17mm
Packing	100PCS / bag
Parameters	Rated Voltage 400V Rated Current 32A Rated Power 7KW



產品型號	LSM2265
適用導線	硬線2.5mm ² /軟線4mm ² (可分四路)
產品規格	26.6x20.5x14.5mm
包裝規格	100個/包
技術參數	額定電壓400V 額定電流32A 額定功率7KW
Model	LSM2265
Wire Range	Hard wire 2.5mm ² / Soft wire 4mm ²
Dimensions	26.6x20.5x14.5mm
Packing	100PCS / bag
Parameters	Rated Voltage 400V Rated Current 32A Rated Power 7KW

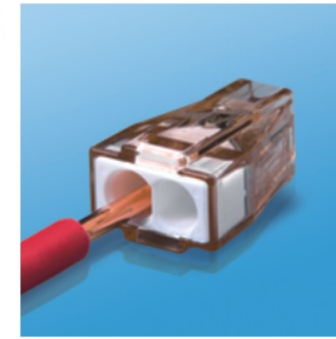

產品型號	LSM5232
適用導線	硬線2.5mm ² (一進一出)
產品規格	19.4x9.2x13mm
包裝規格	100個/包
技術參數	額定電壓400V 額定電流32A 額定功率5KW
Model	LSM5232
Wire Range	Hard wire 2.5mm ²
Dimensions	19.4x9.2x13mm
Packing	100PCS / bag
Parameters	Rated Voltage 400V Rated Current 32A Rated Power 5KW



產品型號	LSM5234
適用導線	硬線2.5~4mm ² (一進三出)
產品規格	19.5x13.3x12.9mm
包裝規格	100個/包
技術參數	額定電壓400V 額定電流32A 額定功率5KW
Model	LSM5234
Wire Range	Hard wire 2.5~4mm ²
Dimensions	19.5x13.3x12.9mm
Packing	100PCS / bag
Parameters	Rated Voltage 400V Rated Current 32A Rated Power 5KW



產品型號	LSM5233
適用導線	硬線2.5~6mm ² (一進二出)
產品規格	20x26.2x14.3mm
包裝規格	100個/包
技術參數	額定電壓400V 額定電流32A 額定功率9KW
Model	LSM5233
Wire Range	Hard wire 2.5~6mm ²
Dimensions	20x26.2x14.3mm
Packing	100PCS / bag
Parameters	Rated Voltage 400V Rated Current 32A Rated Power 9KW



產品型號	LSM5236
適用導線	硬線2.5~4mm ² (一進五出)
產品規格	19.5x18.8x13.1mm
包裝規格	100個/包
技術參數	額定電壓400V 額定電流32A 額定功率5KW
Model	LSM5236
Wire Range	Hard wire 2.5~4mm ²
Dimensions	19.5x18.8x13.1mm
Packing	100PCS / bag
Parameters	Rated Voltage 400V Rated Current 32A Rated Power 5KW

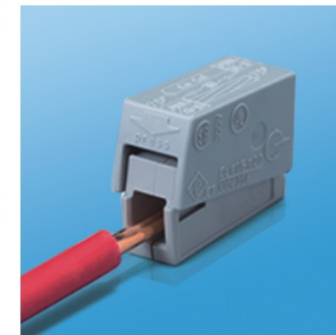

產品型號	LSM-111
適用導線	硬線2.5mm ² (一進一出)
產品規格	20.5x8.8x15.5mm
包裝規格	100個/包
技術參數	額定電壓400V 額定電流32A 額定功率5KW
Model	LSM-111
Wire Range	Hard wire 2.5mm ²
Dimensions	20.5x8.8x15.5mm
Packing	100PCS / bag
Parameters	Rated Voltage 400V Rated Current 32A Rated Power 5KW

電動開關系列 Electric switch series



HTDC Series 防塵(帶剎車)直流扳機調速開關



HTDC Series 防塵(帶剎車)直流扳機調速開關

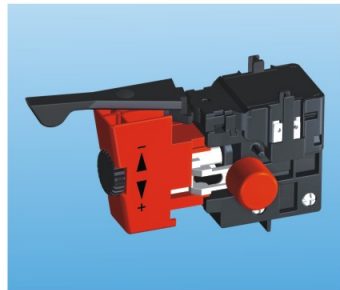

HT1010 Series 防塵交流扳機調速開關



HT1010 Series 防塵交流扳機調速開關



HT1009 Series 防塵交流扳機調速開關



HT1009 Series 防塵交流扳機調速開關

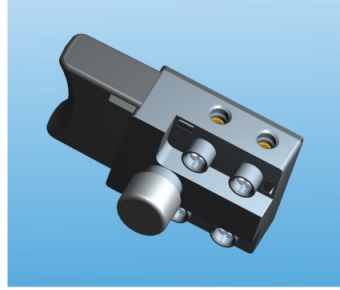

HT1007 Series 防塵交流扳機開關



HT1004 Series 防塵交流扳機開關

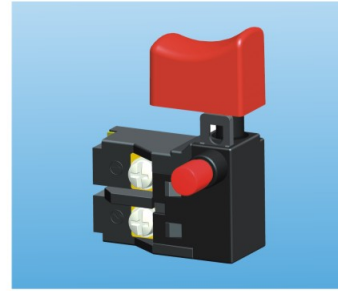

HT1001Series交流扳機開關



HT1001Series交流扳機開關

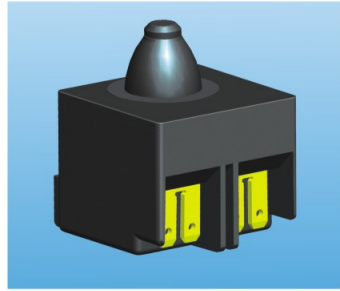

HT1006 Series 防塵按鈕開關



HT1002 Series 踏板開關



HT1005 Series 微動開關



HT1208 Series 搖桿開關

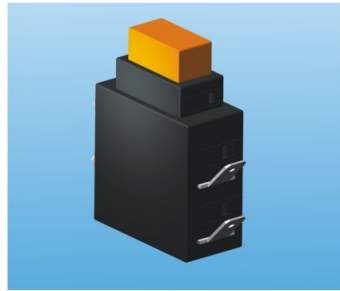

HT1209 Series 直流開關



HT1003 Series 交流防塵轉盤調速器



HT1008 Series 小型交流防塵轉盤調速器

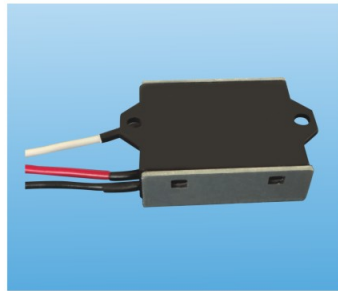

HT1115調速控制器系列

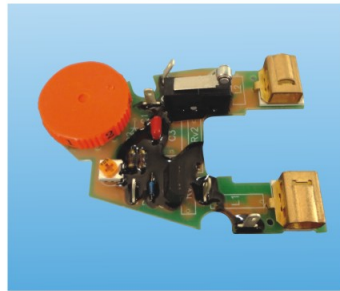

HT1102調速控制器系列

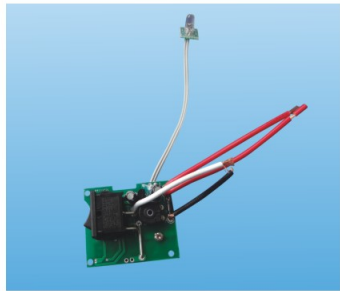

HT1125調速控制器系列



Blank area with horizontal dashed lines for notes.

HONT®

宏泰扎带，领先制造
HONT Cable Tie, Leading manufacturer

HONT®

专利产品，优质保证
Patented Products, Quality Assurance



- 高端尼龙扎带；
- 拉力超过普通尼龙扎带 **25%**；
- 该产品比普通尼龙扎带更易于操作，穿插力小 **50%**；

- High quality cable ties;
- **25%** more stronger;
- Insert force reduce **50%**;

领先制造 · 高端品质
创新理念 · 专利技术 · 新品推荐

Leading Manufacturing · High Quality · Innovative Idea
Patent Technology · New Recommend