



OUR GLOBAL
COMPETENCE
CENTRES

 APOLLO DISPLAY
TECHNOLOGIES



 DISTEC



 DISPLAY
TECHNOLOGY



Datasheet

Amoled Corporation

AL240FHL01-N

AM-01-002

The information contained in this document has been carefully researched and is, to the best of our knowledge, accurate. However, we assume no liability for any product failures or damages, immediate or consequential, resulting from the use of the information provided herein. Our products are not intended for use in systems in which failures of product could result in personal injury. All trademarks mentioned herein are property of their respective owners. All specifications are subject to change without notice.



Product Specification

- () Preliminary Specification
- (●) Final Specification

Model Name: AL240FHL01-N

Product Name: 24 inch 1920 x 1080 TFT LCD Module

Customer	
Approved By	Date
_____	_____
_____	_____

AMOLED Corporation	
Approved By	Date
_____	_____
Prepared By	Date
Stanley	25 Feb. 2016
_____	_____



Contents

1. General Description	4
1.1 Specifications	4
2. Mechanical Drawing.....	5
3. Pin Assignment.....	7
3.1 TFT LCD Module	7
3.2 Backlight Unit	8
4. Absolute Maximum Ratings	8
4.1 TFT LCD Module	8
4.2 Backlight Unit	8
4.3 Absolute Ratings of Environment.....	8
5. Electrical Characteristics	9
5.1 TFT LCD Module	9
5.1.1 Power Specification.....	9
5.1.2 Backlight Unit	10
5.2 Signal Characteristic.....	10
5.2.1 Pixel Format Image.....	10
5.2.2 The Input Data Format	11
5.3 Interface Timing	11
5.3.1 Timing Characteristics.....	11
5.3.2 Input Timing Diagram.....	12
5.4 Power ON/OFF Sequence.....	12
5.5 LVDS Characteristics	13
6. Connector.....	14
6.1 TFT LCD Module	14
6.2 Backlight Unit	14
7. Block Diagram	14
8. Optical Characteristics.....	15
9. Precautions.....	18
10. Packaging.....	19
11. Reliability Test	20



1. General Description

This specification applies to the 24 inch-wide Color TFT-LCD Module AL240FHL01-N. The display supports the Full HD - 1920(H) x 1080(V) screen format and 16.7M colors (RGB 8-bits data). All input signals are dual channel LVDS interface.

AL240FHL01-N is designed for industrial display applications.

1.1 Specifications

The following items are characteristics summary on the table under 25 °C condition:

Item	Unit	Specification
Screen Diagonal	[mm]	609.7(24.0")
Active Area	[mm]	531.36 (H) x 298.89 (V)
Pixels H x V	-	1920 (RGB) x 1080
Pixel Pitch	[um]	276.75 x 276.75
Pixel Arrangement	-	R.G.B. Vertical Stripe
Display Mode	-	VA Mode, Normally Black
White Luminance	[cd/m ²]	1000
Contrast Ratio	-	5000:1
Optical Response Time	[ms]	25
Nominal Input Voltage VDD	[Volt]	+5.0V
Power Consumption	[Watt]	37.4 Watt (typical)
Weight	[g]	2300 (typical)
Physical Size (H x V x D)	[mm]	556.0 (W) x 323.2 (H) x 17.0 (D)
Electrical Interface	-	Dual channel LVDS
Support Color	-	16.7M colors (true 8-bit)
Surface Treatment	-	Anti-Glare, 3H
Temperature Range	[°C] [°C]	-20 to +70 → Operating -30 to +80 → Storage (Non-Operating)
RoHS Compliance	-	RoHS Compliance



2. Mechanical Drawing

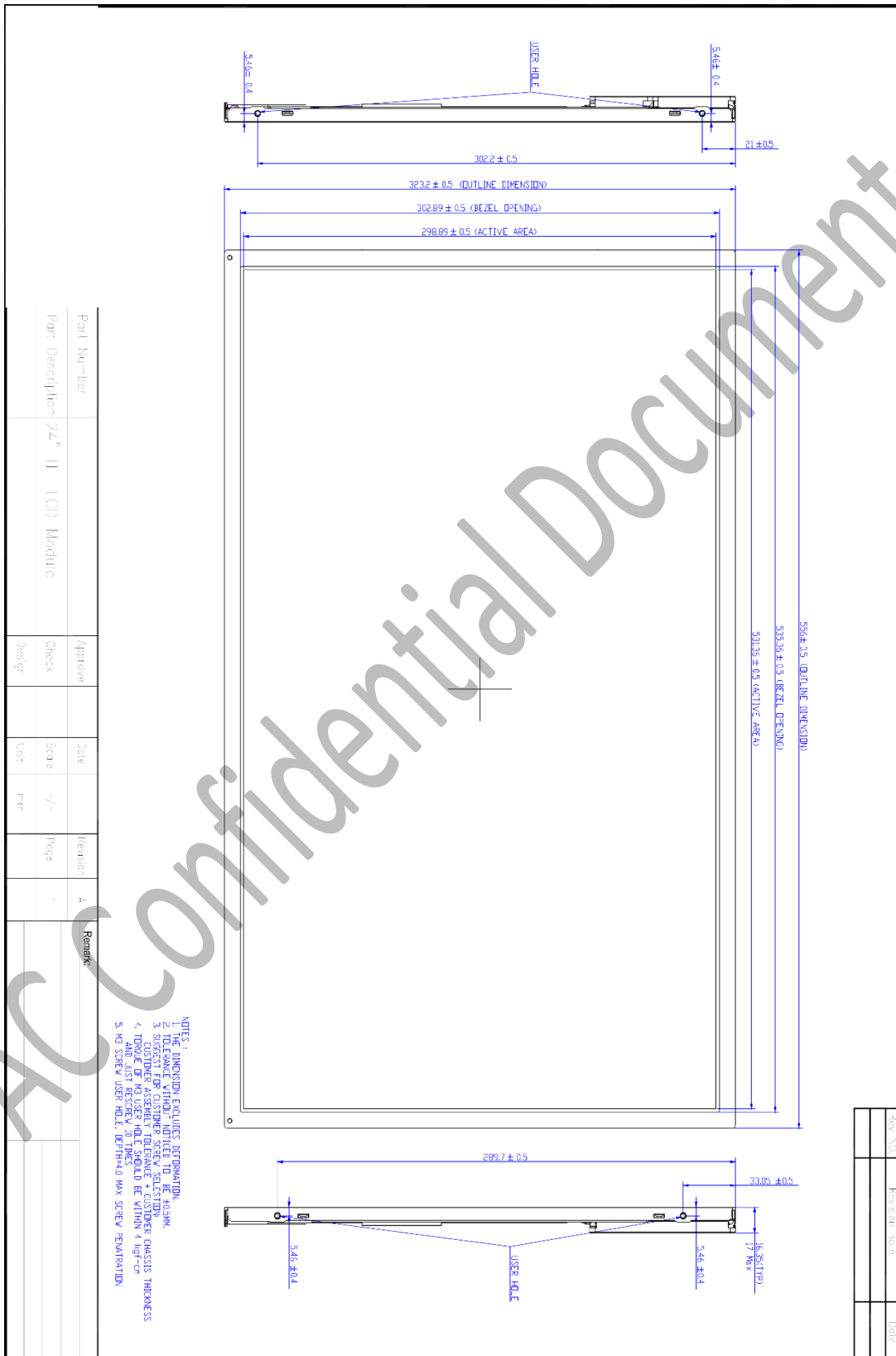

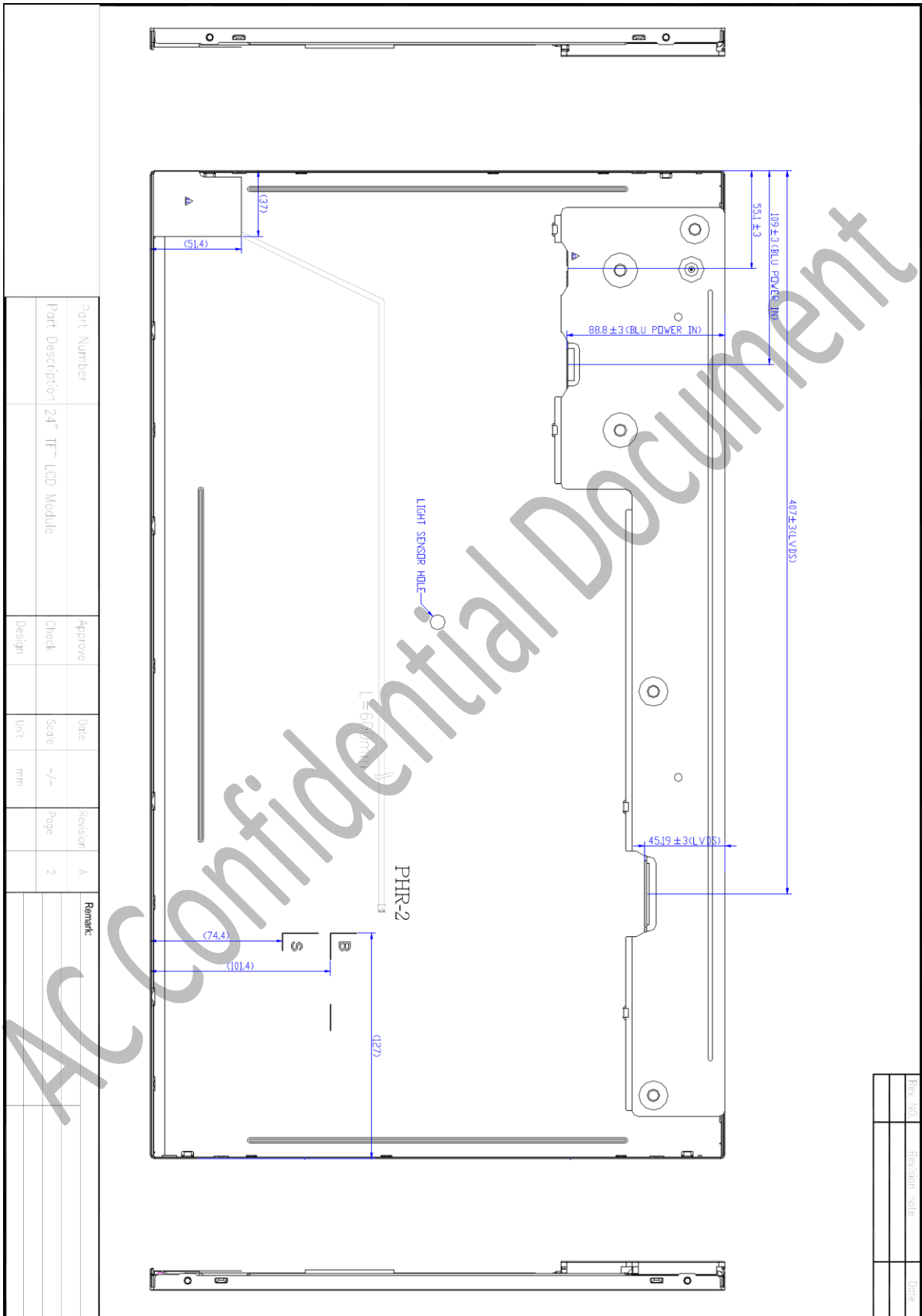



3. Pin Assignment

The module using a pair of LVDS receiver SN75LVDS82 (Texas Instruments) or compatible. LVDS is a differential signal technology for LCD interface and high speed data transfer device. Transmitter shall be SN75LVDS83 (negative edge sampling) or compatible. The first LVDS port (RxOxxx) transmits odd pixels while the second LVDS port (RxExxx) transmits even pixels.

3.1 TFT LCD Module

Pin No.	Signal Name	Description
1	RXinO0-	Negative LVDS differential data input (Odd data)
2	RXinO0+	Positive LVDS differential data input (Odd data)
3	RXinO1-	Negative LVDS differential data input (Odd data)
4	RXinO1+	Positive LVDS differential data input (Odd data)
5	RXinO2-	Negative LVDS differential data input (Odd data, H-Sync, V-Sync, DSPTMG)
6	RXinO2+	Positive LVDS differential data input (Odd data, H-Sync, V-Sync, DSPTMG)
7	GND	Power Ground
8	RxOCLKIN-	Negative LVDS differential clock input (Odd clock)
9	RxOCLKIN+	Positive LVDS differential clock input (Odd clock)
10	RXinO3-	Negative LVDS differential data input (Odd data)
11	RXinO3+	Positive LVDS differential data input (Odd data)
12	RXinE0-	Negative LVDS differential data input (Even data)
13	RXinE0+	Positive LVDS differential data input (Even data)
14	GND	Power Ground
15	RXinE1-	Negative LVDS differential data input (Even data)
16	RXinE1+	Positive LVDS differential data input (Even data)
17	GND	Power Ground
18	RXinE2-	Negative LVDS differential data input (Even data)
19	RXinE2+	Positive LVDS differential data input (Even data)
20	RxECLKIN-	Negative LVDS differential clock input (Even clock)
21	RxECLKIN+	Positive LVDS differential clock input (Even clock)
22	RXinE3-	Negative LVDS differential data input (Even data)
23	RXinE3+	Positive LVDS differential data input (Even data)
24	GND	Power Ground
25	NC	No contact (For test only)
26	NC	No contact (For test only)
27	VDD	Power +5V
28	VDD	Power +5V
29	VDD	Power +5V
30	VDD	Power +5V



3.2 Backlight Unit

Pin No.	Signal Name	Description
1	Power	Input voltage, (Red color)
2	GND	GND (White color)

4. Absolute Maximum Ratings

4.1 TFT LCD Module

Item	Symbol	Min.	Max.	Unit	Conditions
Logic/LCD Drive Voltage	VDD	0	6.0	[Volt]	Note 1,2

4.2 Backlight Unit

Item	Symbol	Min	Max	Unit	Conditions
LED String Current	I _s	0	1000	[mA]	Note 1,2

4.3 Absolute Ratings of Environment

Item	Symbol	Min.	Max.	Unit	Conditions
Operating Temperature	TOP	-20	+70	[° C]	Note 3
Operation Humidity	HOP	5	90	[%RH]	
Storage Temperature	TST	-30	+80	[° C]	
Storage Humidity	HST	5	90	[%RH]	

Note 1: With in Ta (25°C)

Note 2: Permanent damage to the device may occur if exceeding maximum values

Note 3: For quality performance, please refer to IIS (Incoming Inspection Standard).

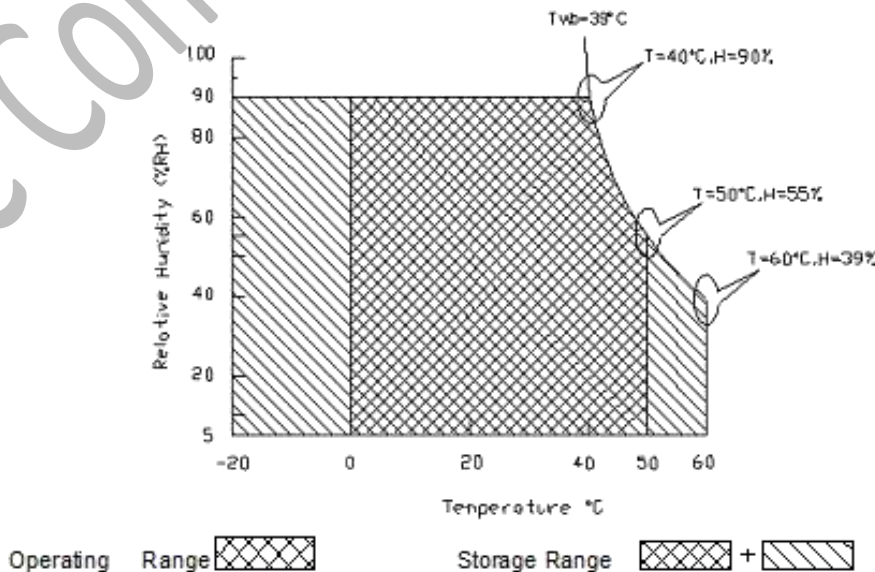



5. Electrical Characteristics

5.1 TFT LCD Module

5.1.1 Power Specification

Symbol	Parameter	Min.	Typ.	Max.	Unit	Conditions
VDD	Logic/LCD Drive Voltage	4.5	5.0	5.5	[Volt]	+/-10%
IDD	VDD Current	-	900	1200	[mA]	VDD= 5.0V, All White Pattern At 60Hz
Irush	Inrush Current	-	-	3	[A]	Note 1
PDD	VDD Power	-	4.5	6	[Watt]	VDD= 5.0V, All White Pattern At 60Hz

Note 1: Measurement conditions:

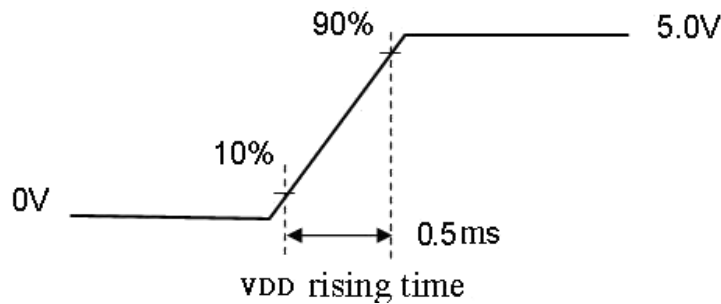
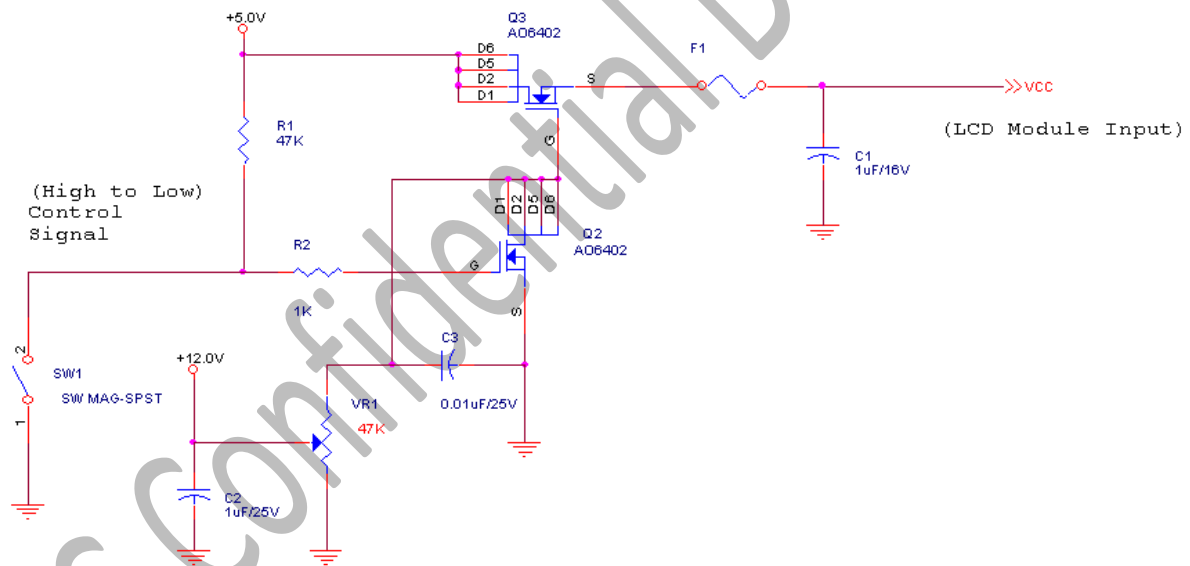



5.2.2 The Input Data Format

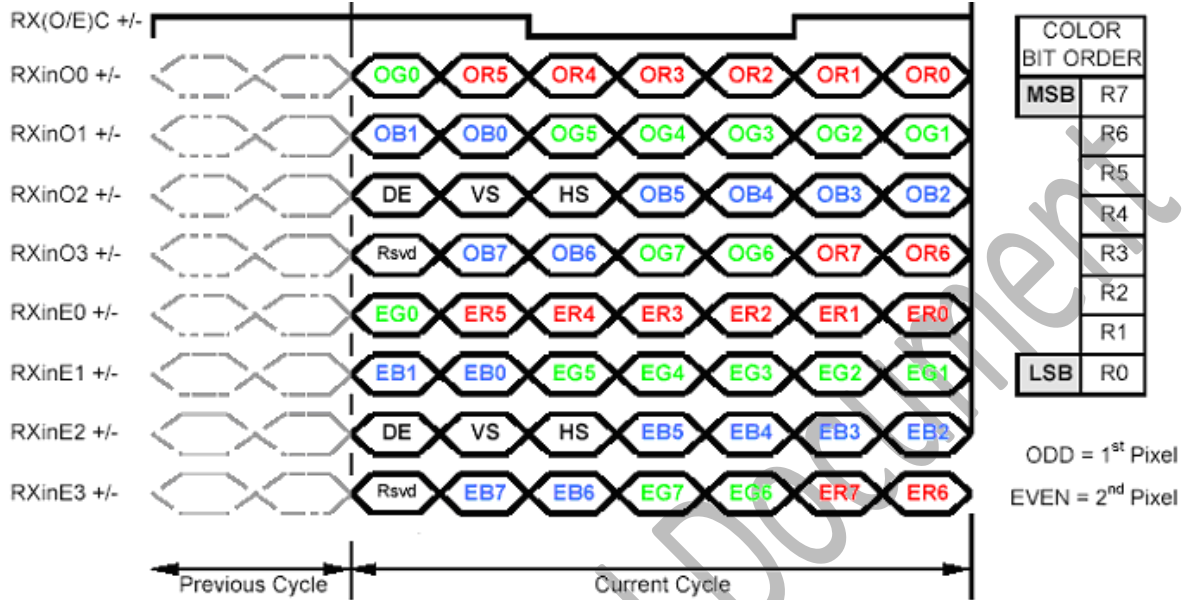

Note1: 8-bit signal input.
Note2: L: NS alike H: Thine alike

5.3 Interface Timing 5.3.1 Timing Characteristics

Signal	Item	Symbol	Min.	Typ.	Max.	Unit
Clock	Frequency	$1/T_{\text{Clock}}$	40	72	83	MHz
	Frame Rate	Frequency	$1/T_v$	50	60	75
Vertical Section	Period	T_v	1088	1120	2047	T_line
	Active	T_{vD}	1080	1080	1080	
	Blanking	T_{vB}	8	40	967	
Horizontal Section	Period	T_H	1034	1060	2047	T_clock
	Active	T_{HD}	960	960	960	
	Blanking	T_{HB}	74	100	1087	

Note : DE mode only.



5.3.2 Input Timing Diagram

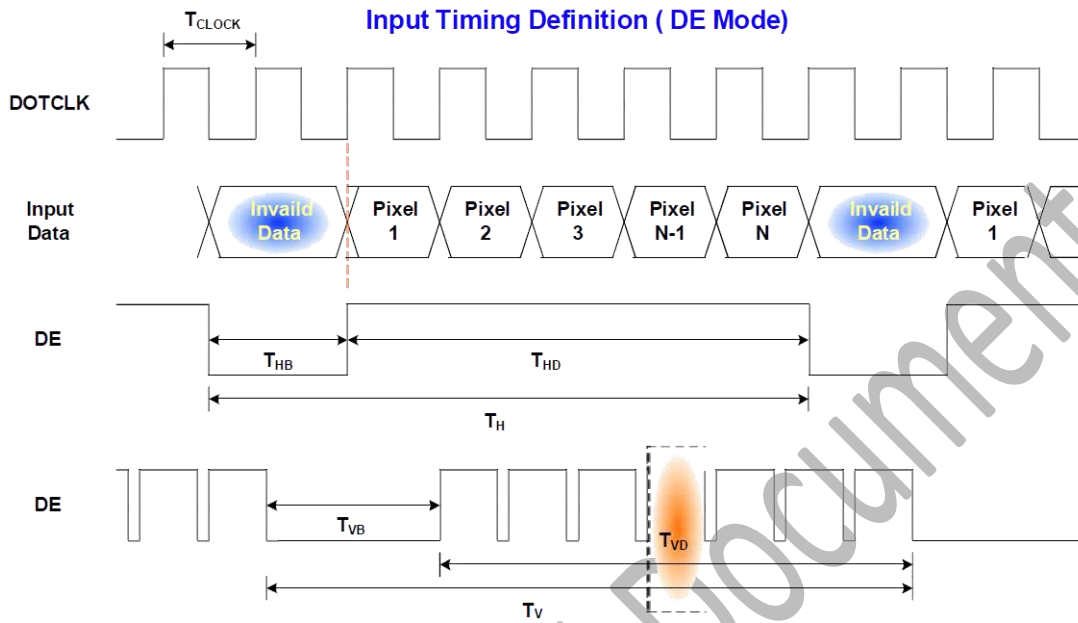

5.4 Power ON/OFF Sequence

VDD power and B/L on/off sequence is as below. Interface signals are also shown in the chart. Signals from any system shall be Hi-Z state or low level when VDD is off.

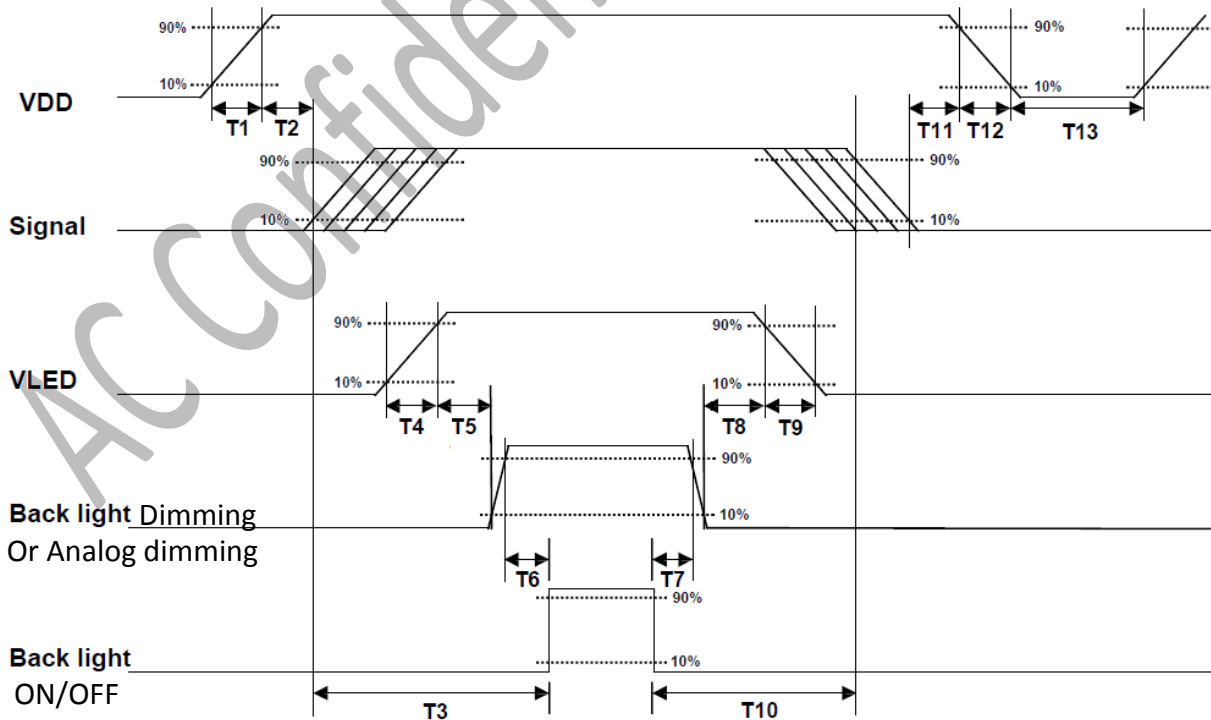



Parameter	Min.	Typ.	Max.	Unit
T1	0.5	-	10	ms
T2	30	40	50	ms
T3	200	-	-	ms
T4	0.5	-	10	ms
T5	10	-	-	ms
T6	10	-	-	ms
T7	0	-	-	ms
T8	10	-	-	ms
T9	-	-	10	ms
T10	110	-	-	ms
T11	0	16	50	ms
T12	-	-	10	ms
T13	1000	-	-	ms

The above on/off sequence should be applied to avoid abnormal function in the display. Please make sure to turn off the power when you plug the cable into the input connector or pull the cable out of the connector.

5.5 LVDS Characteristics

Input signals shall be low or Hi-Z state when VDD is off.

Symbol	Item	Min.	Typ.	Max.	Unit	Remark
VTH	Differential Input High Threshold	-	-	100	[mV]	VCM=1.2V
VTL	Differential Input Low Threshold	-100	-	-	[mV]	VCM=1.2V
VID	Input Differential Voltage	100	400	600	[mV]	-
VICM	Differential Input Common Mode Voltage	0.3	-	1.25	[V]	VTH/VTL=±100mV

Note: LVDS Signal Waveform.

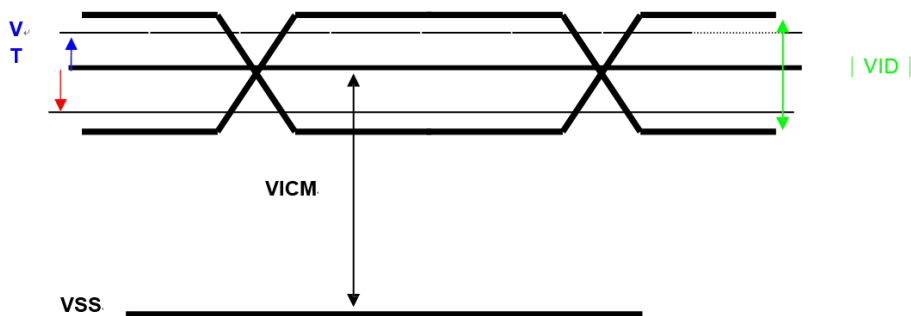



6. Connector

Physical interface is described as for the connector on module. These connectors are capable of accommodating the following signals and will be following components.

6.1 TFT LCD Module

Connector Name / Designation	Interface Connector / Interface Card
Manufacturer	JAE or compatible
Type Part Number	JAE (FI-XB30SRL-HF11) or equivalent.
Mating Housing Part Number	FI-X30HL (JAE) or compatible

6.2 Backlight Unit

Connector Name / Designation	Light Bar Connector
Manufacturer	JST or compatible
Connector Module Number	PHR-2
Mating Housing Part Number	S2B-PH-SM4-TB

7. Block Diagram

The following diagram shows the functional block of the 24 inches wide Color TFT-LCD Module:

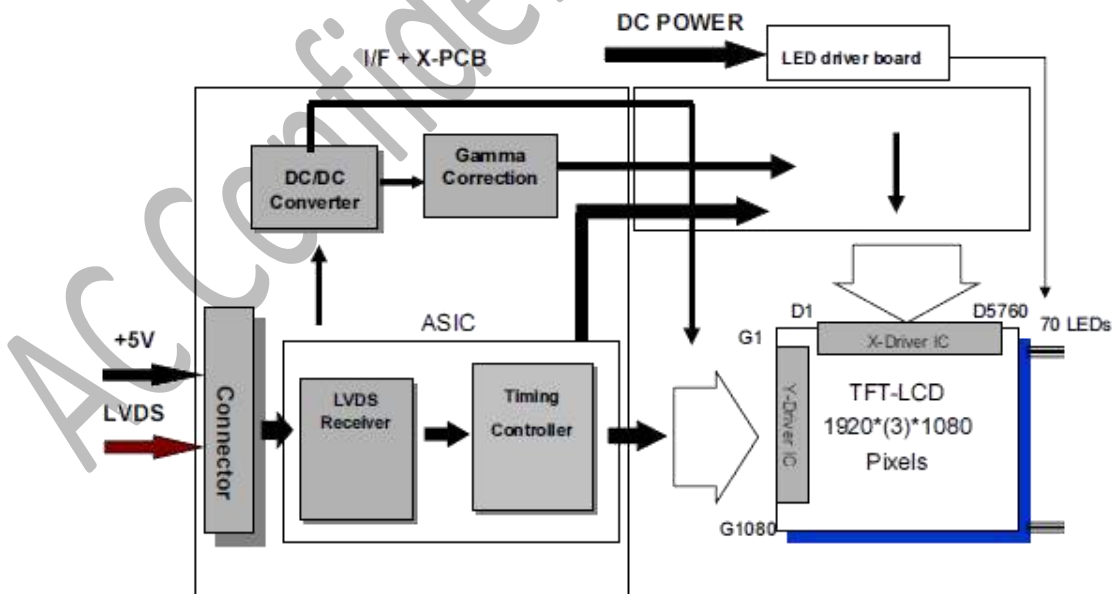

LVDS Connector: JAE (FI-XB30SRL-HF11) or equivalent.

BACKLIGHT connector: JST (PHR-2) or equivalent.



8. Optical Characteristics

The optical characteristics are measured under stable conditions at 25°C (Room Temperature).

Item	Unit	Conditions	Min.	Typ.	Max.	Note
White Luminance	[cd/m ²]	I _F =950mA	800	1000	-	1
Uniformity	%	9 Points	75	80	-	1, 2, 3
Contrast Ratio	-	-	3000	5000	-	4
Cross talk	%	-	-	-	1.5	5
Response Time	[ms]	Rising	-	16	-	6
		Falling	-	9	-	
		Rising + Falling	-	25	-	
Viewing Angle	[degree]	Horizontal (Right)	75	89	-	7
	[degree]	CR = 10 (Left)	75	89	-	
	[degree]	Vertical (Upper)	75	89	-	
Color/Chromaticity Coordinates (CIE 1931)	-	Red x	0.593	0.643	0.693	-
		Red y	0.289	0.339	0.389	
		Green x	0.279	0.329	0.379	
		Green y	0.574	0.624	0.674	
		Blue x	0.105	0.155	0.205	
		Blue y	0.000	0.048	0.098	
		White x	0.263	0.313	0.363	
White y	0.279	0.329	0.379			
Color Gamut	%	-	-	72	-	-

Note 1: Measurement method

Equipment Pattern Generator, Power Supply, Digital Voltmeter, Luminance meter (SR_3 or equivalent)

Aperture 1° with 50cm viewing distance

Test Point Center

Environment < 1 lux

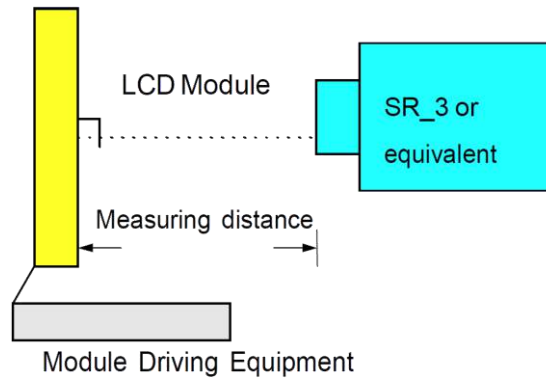

Note 2: Definition of 9 points position. Display active area:

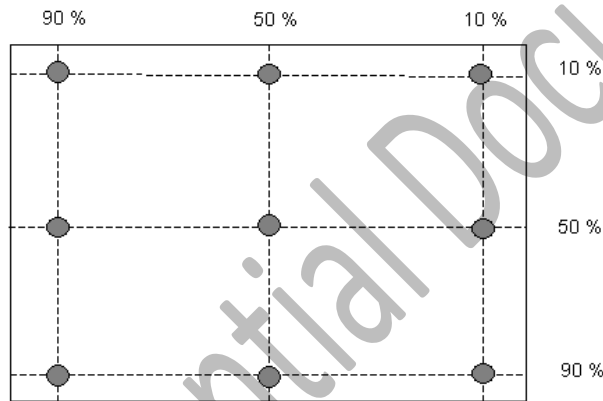

Note 3: The luminance uniformity of 9 points is defined by dividing the minimum luminance values by the maximum test point luminance

$$\delta_{w9} = \frac{\text{Minimum Brightness of 9 points}}{\text{Maximum Brightness of 9 points}}$$

Note 4: Definition of contrast ratio (CR):

$$\text{Contrast ratio (CR)} = \frac{\text{Brightness on the "White" state}}{\text{Brightness on the "Black" state}}$$

Note 5: Definition of cross talk (CT)

$$CT = | YB - YA | / YA \times 100 (\%)$$

Where

YA = Luminance of measured location without gray level 255 pattern (cd/m²)

YB = Luminance of measured location with gray level 255 pattern (cd/m²)

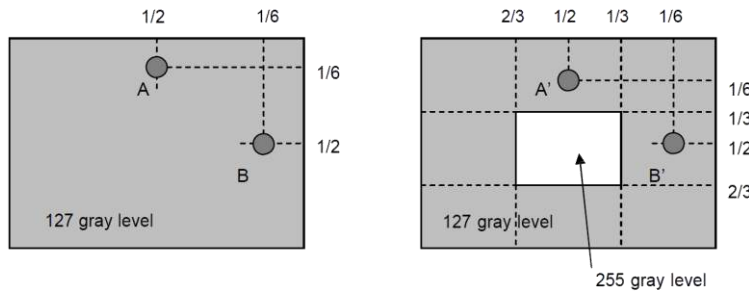

Note 6: Definition of response time:

The output signals of photo detector are measured when the input signals are changed from “White” to “Black” (falling time) and from “Black” to “White” (rising time), respectively. The response time interval is between 10% and 90% of amplitudes. Please refer to the figure as below.

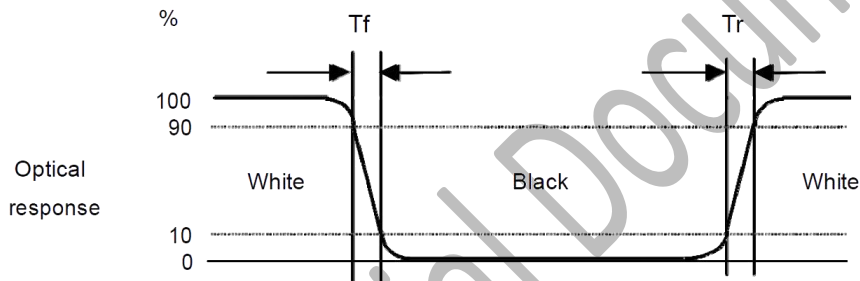

Note 7: Definition of viewing angle

Viewing angle is the measurement of contrast ratio ≥ 10 , at the screen center, over a 180° horizontal and 180° vertical range (off-normal viewing angles). The 180° viewing angle range is broken down as below: 90° (θ) horizontal left and right, and 90° (Φ) vertical high (up) and low (down). The measurement direction is typically perpendicular to the display surface with the screen rotated to its center to develop the desired measurement viewing angle.

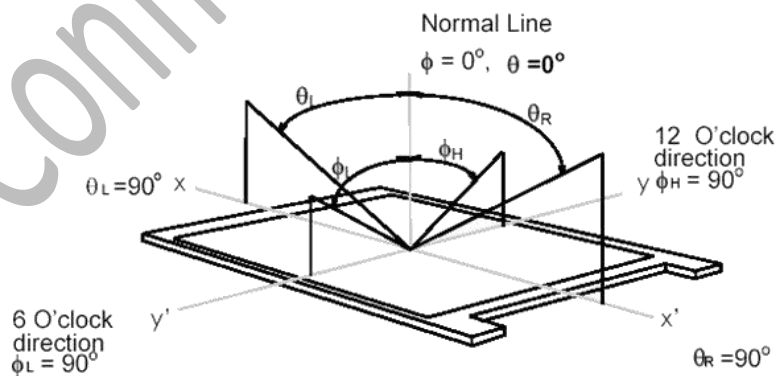

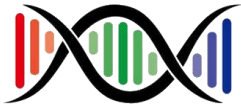

9. Precautions

- 1) Since front polarizer is easily damaged, pay attention not to scratch it.
- 2) Be sure to turn off power supply when inserting or disconnecting from input connector.
- 3) Wipe off water drop immediately. Long contact with water may cause discoloration or spots.
- 4) When the panel surface is soiled, wipe it with absorbent cotton or other soft cloth.
- 5) Since the panel is made of glass, it may break or crack if dropped or bumped on hard surface.
- 6) Since CMOS LSI is used in this module, take care of static electricity and insure human earth when handling.
- 7) Do not open or modify the Module Assembly.
- 8) In case if a Module has to be put back into the packing container slot after once it was taken out from the container, take it easily, or the TFT Module may be damaged.
- 9) At the insertion or removal of the Signal Interface Connector, be sure not to rotate nor tilt the Interface Connector of the TFT Module.
- 10) After installation of the TFT Module into an enclosure, do not twist nor bend the TFT Module even momentary.
At designing the enclosure, it should be taken into consideration that no bending/twisting forces are applied to the TFT Module from outside. Otherwise the TFT Module may be damaged.
- 11) Small amount of materials having no flammability grade is used in the LCD module. The LCD module should be supplied by power complied with requirements of Limited Power Source (IEC60950 or UL1950), or be applied exemption.
- 12) Severe temperature condition may result in different luminance, response time and LED life time.
- 13) The data on this specification sheet is applicable when LCD module is placed in landscape position.
- 14) Continuous displaying fixed pattern may induce image sticking. It is recommended to use screen saver or shuffle content periodically if fixed pattern is displayed on the screen.



10. Packaging

- The outside dimension of carton is 413 x 282x 661 (mm).
- 8 pieces per carton box.
- 2*4 boxes per layer. By air, 2 layer / pallet. By sea, refer packing documents.
Pallet size (not include carton boxes): 1150 mm * 840 mm * 132 mm

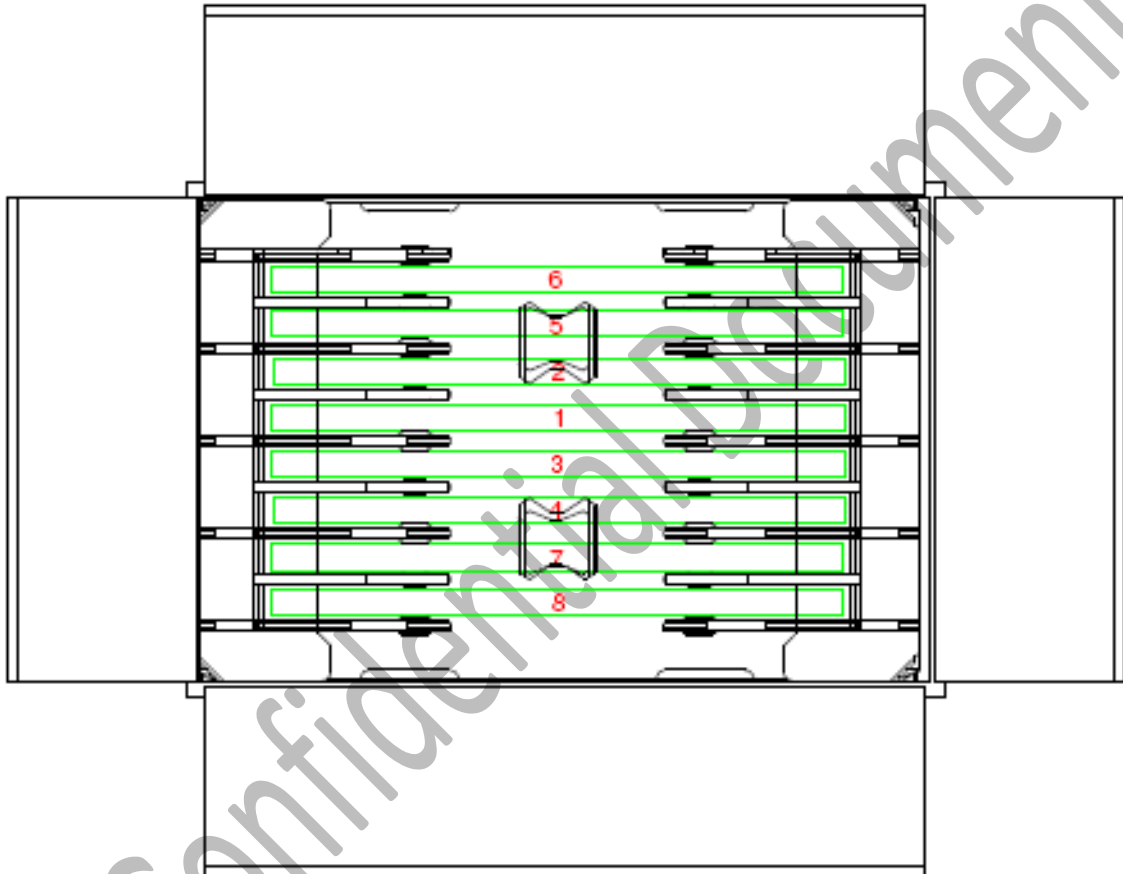



11. Reliability Test

Environment test conditions are listed as following table.

Items	Request Condition	Note
Temperature Humidity Bias (THB)	Ta=50C, 80%RH, 300hours	-
High Temperature Operation (HTO)	Ta=70C, 50%RH, 300hours	-
Low Temperature Operation (LTO)	Ta=-20C, 300hours	-
High Temperature Storage (HTS)	Ta=80C, 300hours	-
Low Temperature Storage (LTS)	Ta= -30C, 300hours	-
Vibration Test (Non- operation)	Acceleration: 1.5 G Wave: Random Frequency: 10 - 200 Hz Duration: 30 Minutes each Axis (X, Y, Z)	-
Shock Test (Non- operation)	Acceleration: 50 G Wave: Half-sine Active Time: 20 ms Direction: ±X, ±Y, ±Z (one time for each Axis)	-
DropTest	Height: 46 cm, package test	-
ThermalShockTest(TST)	-20C/30min, 60C/3/0min, 100 cycles	-
On/Off Test	On/10sec, Off/10sec, 30,000 cycles	-
ESD(ElectroStaticDischarge)	Contact Discharge: ± 8KV, 150pF (330Ω) 1sec, 8 points, 25 times/ point.	1
	Air Discharge: ± 15KV, 150pF (330Ω) 1sec, 8 points, 25 times/ point.	
Altitude Test	Operation: 10,000ft Non-Operation: 30,000ft	-

Note 1: According to EN61000-4-2, ESD class B: Some performance degradation allowed. No data lost Self- recoverable. No hardware failures.

Note 2:

- Water condensation is not allowed for each test items.
- Each test is done by new TFT-LCD module. Don't use the same TFT-LCD module repeatedly for reliability test.
- The reliability test is performed only to examine the TFT-LCD module capability.
- To inspect TFT-LCD module after reliability test, please store it at room temperature and room humidity for 24 hours at least in advance.
- No function failure occurs.

Our company network supports you worldwide with offices in Germany, Austria, Switzerland, the UK and the USA. For more information please contact:

Headquarters

Germany



FORTEC Elektronik AG

Lechwiesenstr. 9
86899 Landsberg am Lech

Phone: +49 8191 91172-0
E-Mail: sales@forteca.de
Internet: www.forteca.de

Fortec Group Members

Austria



FORTEC Elektronik AG

Office Vienna

Nuschinggasse 12
1230 Wien

Phone: +43 1 8673492-0
E-Mail: office@fortec.at
Internet: www.fortec.at

Germany



Distec GmbH

Augsburger Str. 2b
82110 Germering

Phone: +49 89 894363-0
E-Mail: info@distec.de
Internet: www.distec.de

Switzerland



ALTRAC AG

Bahnhofstraße 3
5436 Würenlos

Phone: +41 44 7446111
E-Mail: info@altrac.ch
Internet: www.altrac.ch

United Kingdom



Display Technology Ltd.

Osprey House, 1 Osprey Court
Hichingbrooke Business Park
Huntingdon, Cambridgeshire, PE29 6FN

Phone: +44 1480 411600
E-Mail: info@displaytechnology.co.uk
Internet: www.displaytechnology.co.uk

USA



Apollo Display Technologies, Corp.

87 Raynor Avenue,
Unit 1 Ronkonkoma,
NY 11779

Phone: +1 631 5804360
E-Mail: info@apolloDisplays.com
Internet: www.apolloDisplays.com