

**PROPRIETARY NOTE**

THIS SPECIFICATION IS THE PROPERTY OF BOE HF AND SHALL NOT BE REPRODUCED OR COPIED WITHOUT THE WRITTEN PERMISSION OF BOE HF AND MUST BE RETURNED TO BOE HF UPON ITS REQUEST



SPEC. NUMBER

PRODUCT GROUP

REV.

ISSUE DATE

PAGE  
1 OF 29

TFT- LCD

0

**B3 38.2FHD TLCM R-LCD 项目**  
**Product Specification Rev**

<b>SUPPLIER</b>	
<b>FG-Code</b>	GT382FHM-N10-DMT0

ITEM	BUYER SIGNATURE	DATE
_____	_____	_____
_____	_____	_____
_____	_____	_____

ITEM	SUPPLIER SIGNATURE	DATE
Prepared	_____	_____
Reviewed	_____	_____
Approved	_____	_____



**PROPRIETARY NOTE**

THIS SPECIFICATION IS THE PROPERTY OF BOE HF AND SHALL NOT BE REPRODUCED OR COPIED WITHOUT THE WRITTEN PERMISSION OF BOE HF AND MUST BE RETURNED TO BOE HF UPON ITS REQUEST



SPEC. NUMBER

PRODUCT GROUP

REV.

ISSUE DATE

PAGE

TFT- LCD

0

3 OF 29

## Contents

No.	Items	Page
1.0	General Description	4
2.0	Absolute Maximum Ratings	6
3.0	Electrical Specifications	7
4.0	Optical Specifications.	16
5.0	Mechanical Characteristics	19
6.0	Reliability	22
7.0	Packing	23
8.0	Product Serial Number	24
9.0	Precautions	26

## PROPRIETARY NOTE

THIS SPECIFICATION IS THE PROPERTY OF BOE HF AND SHALL NOT BE REPRODUCED OR COPIED WITHOUT THE WRITTEN PERMISSION OF BOE HF AND MUST BE RETURNED TO BOE HF UPON ITS REQUEST

# BOE

SPEC. NUMBER

PRODUCT GROUP

REV.

ISSUE DATE

PAGE  
4 OF 29

TFT- LCD

0

## 1.0 GENERAL DESCRIPTION

### 1.1 Introduction

38.2 inch module is a color active matrix TFT R-LCD module using a-silicon TFT's (Thin Film Transistors) as an active switching devices. It is a reflective type display operating in the normal white. The TFT-RLCD has a 38.2 inch diagonally measured active area with resolutions (1920 horizontal by 1080 vertical pixel arrays). Each pixel is divided into RED, GREEN, BLUE dots which are arranged in vertical stripe and this panel can display 16.7M colors.

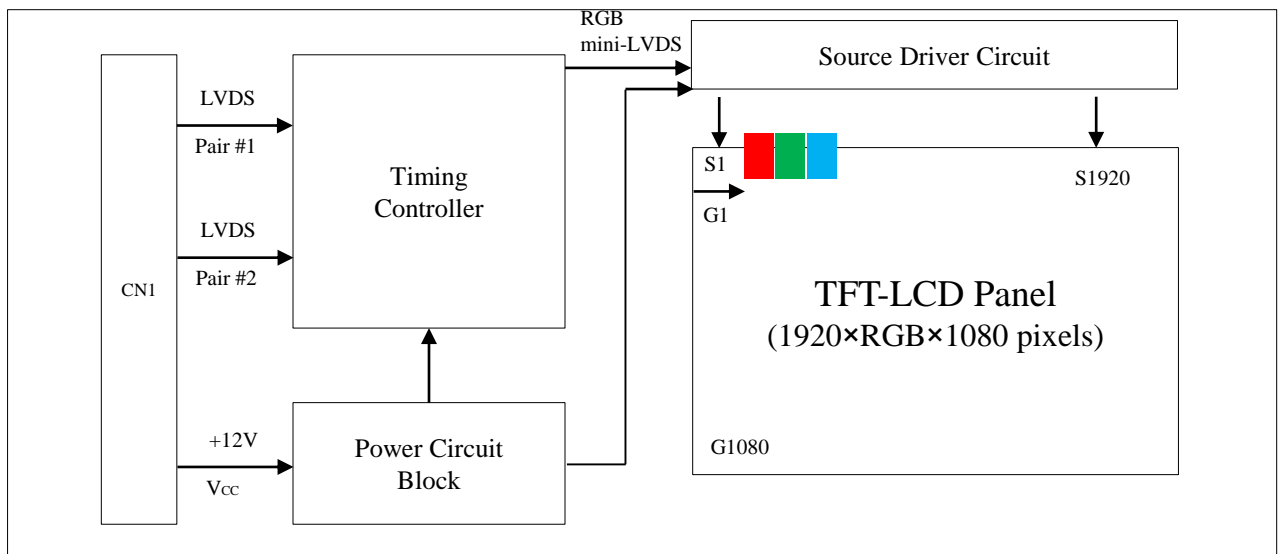

### 1.2 Features

- Wide viewing angle (U/D/L/R): [Typ.55/50/55/55@CR>2:1](#)
- Color Gamut: 12%
- RoHS/Halogen Free
- LVDS Interface
- 0.5T +0.5T glass

### 1.3 Application

- IoT Production

**PROPRIETARY NOTE**

THIS SPECIFICATION IS THE PROPERTY OF BOE HF AND SHALL NOT BE REPRODUCED OR COPIED WITHOUT THE WRITTEN PERMISSION OF BOE HF AND MUST BE RETURNED TO BOE HF UPON ITS REQUEST



SPEC. NUMBER

PRODUCT GROUP

REV.

ISSUE DATE

PAGE  
5 OF 29

TFT- LCD

0

**1.4 General Specification** Table 1-1 General Specifications

Parameter	Specification	Unit	Remarks
Active area	845.57(H)x475.63(V)	mm	-
Number of pixels	1920(H) × RGB ×1080(V)	pixels	
Pixel pitch	146.8 × 440.4	um	
Pixel arrangement	RGB Vertical stripe		
Display colors	16.7M	colors	
Color gamut	12	%	Typ.
Display mode	Normally White/Reflective		
Viewing Direction (Human Eye)	U/D/L/R 55/50/55/55	Deg.	Typ.
Surface coating	AG:3%,AF:110±5°		
Dimensional outline	892*532*7.92	mm	Thickness: 9mm Max
Weight	7400 Spec, 7800 Max	g	
Power Consumption	2.3 (LCD) + 30.24 (Front Light)	Watt	Typ.
Bezel width	22.7/22.7/22.7/22.7	mm	(L/R/U/D)
Driver IC	6 * ICNL9308	EA	COF

Note:

1.At the U/D/L/R direction, the viewing angle is different;

**1.5.The TFT and CF Align Direction;**

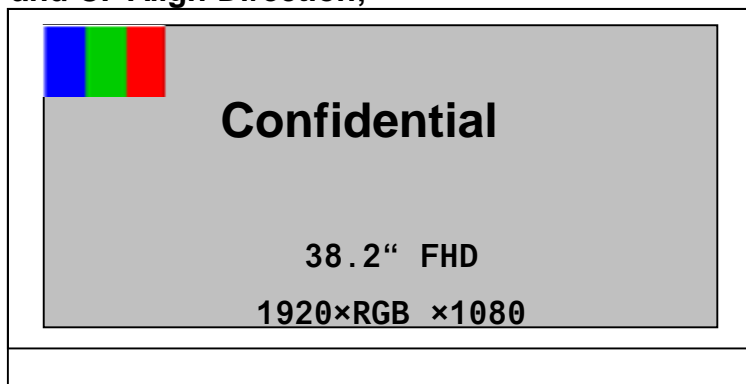

Figure 1-3 The TFT and CF Align Direction

**PROPRIETARY NOTE**

THIS SPECIFICATION IS THE PROPERTY OF BOE HF AND SHALL NOT BE REPRODUCED OR COPIED WITHOUT THE WRITTEN PERMISSION OF BOE HF AND MUST BE RETURNED TO BOE HF UPON ITS REQUEST



SPEC. NUMBER

PRODUCT GROUP

REV.

ISSUE DATE

PAGE

TFT- LCD

0

6 OF 29

**2.0 ABSOLUTE MAXIMUM RATINGS**

The followings are maximum values which, if exceed, may cause faulty operation or damage to the unit. The operational and non-operational maximum voltage and current values are listed in Table 2-1

Table 2-1 Environment Absolute Maximum Ratings

Parameter	Symbol	Min.	Max.	Unit	Remarks
LCD Logic Voltage	VCC	-0.3	14	V	Ta=25+/-2°C
Operating Temperature (Humidity)	T <sub>OP</sub>	-20	+70	°C	
	RH	-	90	%	At 60°C
Storage Temperature (Humidity)	T <sub>ST</sub>	-30	+80	°C	
	RH	-	90	%	At 60°C

**PROPRIETARY NOTE**

THIS SPECIFICATION IS THE PROPERTY OF BOE HF AND SHALL NOT BE REPRODUCED OR COPIED WITHOUT THE WRITTEN PERMISSION OF BOE HF AND MUST BE RETURNED TO BOE HF UPON ITS REQUEST



SPEC. NUMBER

PRODUCT GROUP

REV.

ISSUE DATE

PAGE

TFT- LCD

0

7 OF 29

**3.0 ELECTRICAL SPECIFICATIONS****3.1 The LCD Module Electrical Interface Connection**

Table 3-1 Pin Assignments for the LCD  
(Module Side Connector : UJC PM.LVS.S040505101 or Equivalent)

PIN	SYMBOL	Description	Remark
1	VCC	Power Supply	TYP: 12V
2	VCC	Power Supply	TYP: 12V
3	VCC	Power Supply	TYP: 12V
4	VCC	Power Supply	TYP: 12V
5	VCC	Power Supply	TYP: 12V
6	NC	Not Connect	
7	GND	Ground	
8	GND	Ground	
9	GND	Ground	
10	RX00-	Negative Transmission data of Pixel 0 (ODD)	
11	RX00+	Positive Transmission data of Pixel 0 (ODD)	
12	RX01-	Negative Transmission data of Pixel 1 (ODD)	
13	RX01+	Positive Transmission data of Pixel 1 (ODD)	
14	RX02-	Negative Transmission data of Pixel 2 (ODD)	
15	RX02+	Positive Transmission data of Pixel 2 (ODD)	
16	GND	Ground	
17	RXOCLK-	Negative Transmission Clock (ODD)	
18	RXOCLK+	Positive Transmission Clock (ODD)	
19	GND	Ground	
20	RX03-	Negative Transmission data of Pixel 3(ODD)	
21	RX03+	Positive Transmission data of Pixel 3 (ODD)	
22	NC	Not Connect	
23	NC	Not Connect	
24	GND	Ground	
25	RXE0-	Negative Transmission data of Pixel 0 (EVEN)	
26	RXE0+	Positive Transmission data of Pixel 0 (EVEN)	
27	RXE1-	Negative Transmission data of Pixel 1 (EVEN)	
28	RXE1+	Positive Transmission data of Pixel 1 (EVEN)	
29	RXE2-	Negative Transmission data of Pixel 2 (EVEN)	

**PROPRIETARY NOTE**

THIS SPECIFICATION IS THE PROPERTY OF BOE HF AND SHALL NOT BE REPRODUCED OR COPIED WITHOUT THE WRITTEN PERMISSION OF BOE HF AND MUST BE RETURNED TO BOE HF UPON ITS REQUEST

**BOE**

SPEC. NUMBER

PRODUCT GROUP

REV.

ISSUE DATE

PAGE

TFT- LCD

0

8 OF 29

PIN	SYMBOL	Description	Remark
30	RXE2+	Positive Transmission data of Pixel 2 (EVEN)	
31	GND	Ground	
32	RXECLK-	Negative Transmission Clock (EVEN)	
33	RXECLK+	Positive Transmission Clock (EVEN)	
34	GND	Ground	
35	RXE3-	Negative Transmission data of Pixel 3 (EVEN)	
36	RXE3+	Positive Transmission data of Pixel 3 (EVEN)	
37	NC	Not Connect	
38	NC	Not Connect	
39	GND	Ground	
40	NC	For internal use only, Not Connect	
41	NC	For internal use only, Not Connect	
42	NC	For internal use only, Not Connect	
43	NC	For internal use only, Not Connect	
44	NC	Not Connect	
45	NC	For internal use only, Not Connect	
46	NC	Not Connect	
47	NC	Not Connect	
48	NC	Not Connect	
49	NC	Not Connect	
50	NC	Not Connect	
51	NC	Not Connect	

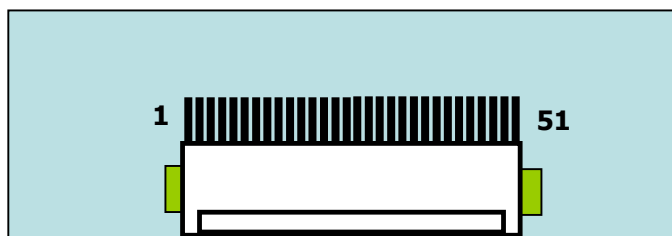
**Rear view of LCM**



**PROPRIETARY NOTE**

THIS SPECIFICATION IS THE PROPERTY OF BOE HF AND SHALL NOT BE REPRODUCED OR COPIED WITHOUT THE WRITTEN PERMISSION OF BOE HF AND MUST BE RETURNED TO BOE HF UPON ITS REQUEST

**BOE**

SPEC. NUMBER

PRODUCT GROUP

REV.

ISSUE DATE

PAGE

TFT- LCD

0

9 OF 29

**3.4 Electrical Specifications**

Table 3-3 Electrical Specifications

Ta=25+/-2°C

Parameter		Symbol	Values			Unit	Remark
			Min	Typ	Max		
Power Supply Input Voltage		VCC	11.5	12	12.5	Vdc	
Power Supply Ripple Voltage		VRP			300	mV	Note 3
Power Supply Current		ICC	-	192	417	mA	Note 1&4
Power Consumption		PCC		2.3	5	Watt	
Rush current		IRUSH	-	-	3	A	Note 2
LVDS Interface	Differential Input High Threshold Voltage	VLVTH	+100		+300	mV	
	Differential Input Low Threshold Voltage	VLVTL	-300		-100	mV	
	Common Input Voltage	VLVC	1.0	1.2	1.4	V	

Notes : 1. The supply voltage is measured and specified at the interface connector of LCM.

The current draw and power consumption specified is for VCC=12.0V, Frame rate=60Hz

Clock frequency = 74.25 MHz. Test Pattern of power supply current

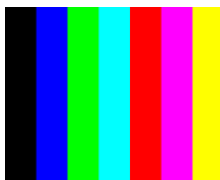

Test pattern: Color Test

2. Duration of rush current is about 2 ms and rising time of VCC is  $520 \mu\text{s} \pm 20\%$

3. Ripple Voltage should be covered by Input voltage Spec.

4. Calculated value for reference (Input pins\*VPIN ×IPIN) including inverter loss.

**PROPRIETARY NOTE**

THIS SPECIFICATION IS THE PROPERTY OF BOE HF AND SHALL NOT BE REPRODUCED OR COPIED WITHOUT THE WRITTEN PERMISSION OF BOE HF AND MUST BE RETURNED TO BOE HF UPON ITS REQUEST



SPEC. NUMBER

PRODUCT GROUP

REV.

ISSUE DATE

PAGE  
10 OF 29

TFT- LCD

0

**3.5 Front Light Characteristics**

Table 3-4 Front Light Characteristics

Item	Symbol	Condition	Min.	Typ.	Max.	Unit
Forward Voltage	Vf			36		V
Forward Current	IF1			420		mA
Forward Current	IF2			420		mA
Power Consumption	Pd			30.24		W
Driver Method	DC,恒流					
LED Configuration	聚飞, 2810, Y粉					

FRONT LIGHT CIRCUIT:  
 2EA FRONT LIGHT BAR,  
 LED QTY/EA:12\*21=252PCS  
 Vf=34--36V , If=21\*20=420mA (参考)

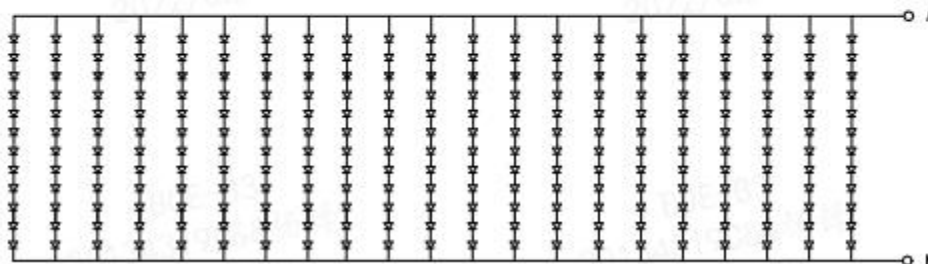

Figure 3-1 Front Light Circuit

**PROPRIETARY NOTE**

THIS SPECIFICATION IS THE PROPERTY OF BOE HF AND SHALL NOT BE REPRODUCED OR COPIED WITHOUT THE WRITTEN PERMISSION OF BOE HF AND MUST BE RETURNED TO BOE HF UPON ITS REQUEST



SPEC. NUMBER

PRODUCT GROUP

REV.

ISSUE DATE

PAGE  
11 OF 29

TFT- LCD

0

**3.6 LVDS Signal Timing**

Table 3-5 LVDS Signal Timing

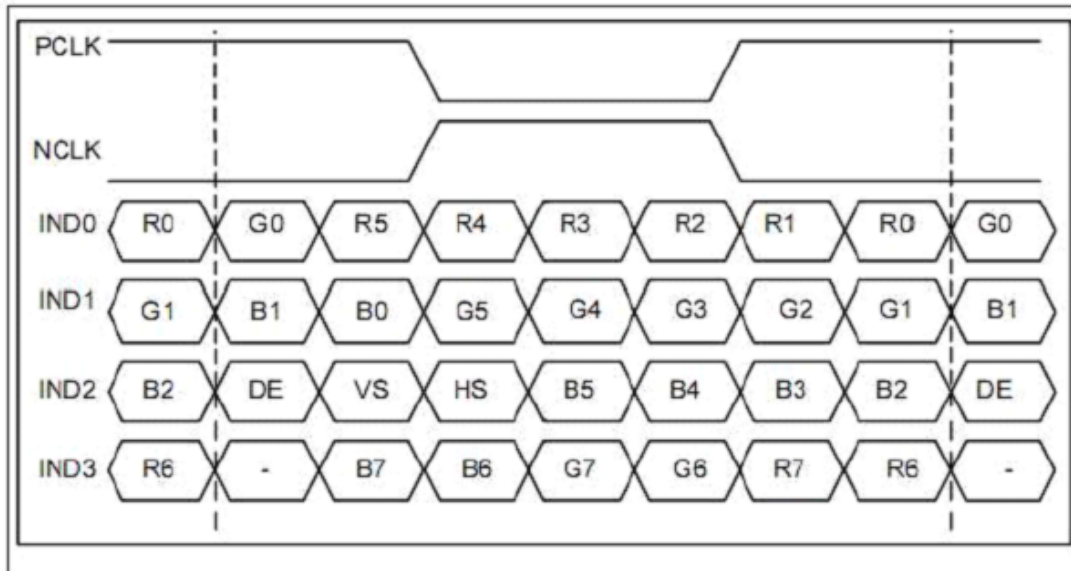

**PROPRIETARY NOTE**

THIS SPECIFICATION IS THE PROPERTY OF BOE HF AND SHALL NOT BE REPRODUCED OR COPIED WITHOUT THE WRITTEN PERMISSION OF BOE HF AND MUST BE RETURNED TO BOE HF UPON ITS REQUEST



SPEC. NUMBER

PRODUCT GROUP

REV.

ISSUE DATE

PAGE  
12 OF 29

TFT- LCD

0

Table 3-6 LVDS Signal Timing

Item	Symbol	Min	Typ	Max	Unit	Remark
CLKIN Period	tRCIP	12.82	13.47	15.87	nsec	
Input Data 0	tRIP1	-0.4	0.0	+0.4	nsec	
Input Data 1	tRIP0	tRCIP/7-0.42	tRCIP/7	tRCIP/7+0.42	nsec	
Input Data 2	tRIP6	2 × tRCIP/7-0.42	2 × tRCIP/7	2 × tRCIP/7+0.42	nsec	
Input Data 3	tRIP5	3 × tRCIP/7-0.42	3 × tRCIP/7	3 × tRCIP/7+0.42	nsec	
Input Data 4	tRIP4	4 × tRCIP/7-0.42	4 × tRCIP/7	4 × tRCIP/7+0.42	nsec	
Input Data 5	tRIP3	5 × tRCIP/7-0.42	5 × tRCIP/7	5 × tRCIP/7+0.42	nsec	
Input Data 6	tRIP2	6 × tRCIP/7-0.42	6 × tRCIP/7	6 × tRCIP/7+0.42	nsec	

**3.7 LVDS Signal Timing**

Table 3-7 LVDS Signal Timing

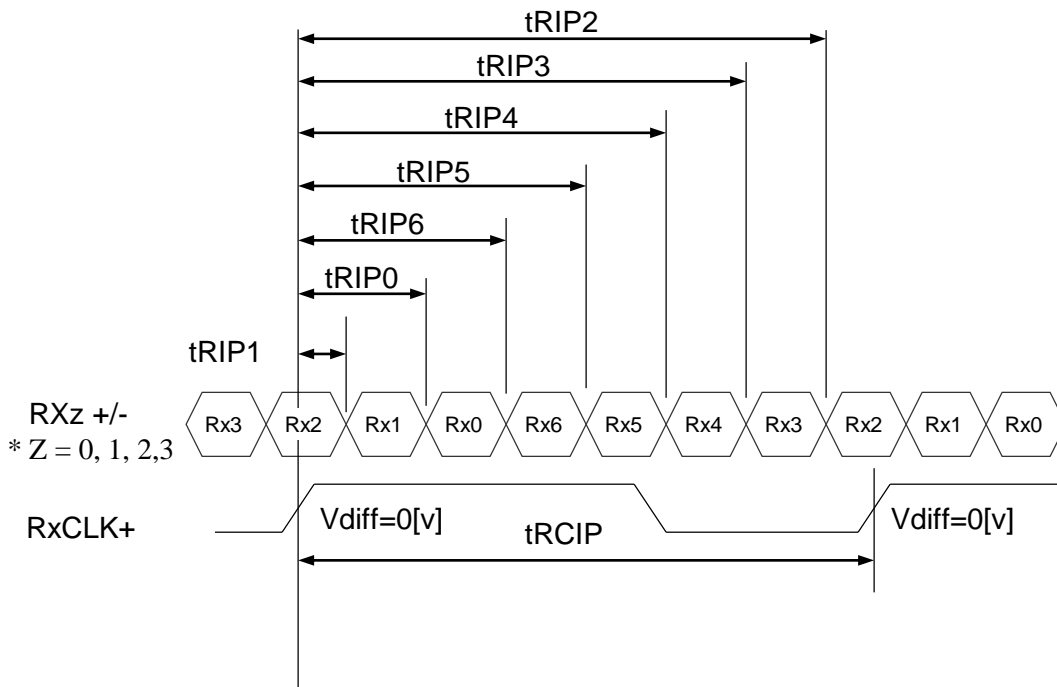

\* Vdiff = (RXz+)-(RXz-),.... ,(RXCLK+)-(RXCLK-)

**PROPRIETARY NOTE**

THIS SPECIFICATION IS THE PROPERTY OF BOE HF AND SHALL NOT BE REPRODUCED OR COPIED WITHOUT THE WRITTEN PERMISSION OF BOE HF AND MUST BE RETURNED TO BOE HF UPON ITS REQUEST

**BOE**

SPEC. NUMBER

PRODUCT GROUP

REV.

ISSUE DATE

PAGE

TFT- LCD

0

13 OF 29

Table 3-8 LVDS Signal Timing

Item		Symbols	Min	Typ	Max	Unit	
Clock	Frequency	1/Tc	58	74.25	78	MHz	
	High Time	Tch	-	4/7Tc	-		
	Low Time	Tcl	-	3/7Tc	-		
Frame Period		Tv	-	60	-	Hz	
Horizontal Active Display Term		Valid	t <sub>HV</sub>	-	960	-	t <sub>CLK</sub>
		Total	t <sub>HP</sub>	1060	1100	1200	t <sub>CLK</sub>
Vertical Active Display Term		Valid	t <sub>VV</sub>	-	1080	-	t <sub>HP</sub>
		Total	t <sub>VP</sub>	1100	1125	1200	t <sub>HP</sub>

Notes: This product is DE only mode. The input of Hsync & Vsync signal does not have an effect on normal operation. All of above parameter must be in Spec at the same time.

Table 3-9 LVDS Signal SSC

Symbol	Parameter	Condition	Min	Typ	Max	Unit
F	LVDS Input frequency	-	58	74.25	78	MHz
T <sub>LVSK</sub>	LVDS channel to channel skew	F=65MHz V <sub>IC</sub> =1.2V V <sub>ID</sub> =±200mV	-400	-	+400	ps
F <sub>LVMOD</sub>	Modulating frequency of input clock during SSC	F=65MHz V <sub>IC</sub> =1.2V V <sub>ID</sub> =±200mV	10	-	100	KHz
F <sub>LVDEV</sub>	Maximum deviation of input clock frequency during SSC		-3	-	+3	%
T <sub>CY-CY</sub>	Cycle to Cycle jitter		-	-	100	ps

**PROPRIETARY NOTE**

THIS SPECIFICATION IS THE PROPERTY OF BOE HF AND SHALL NOT BE REPRODUCED OR COPIED WITHOUT THE WRITTEN PERMISSION OF BOE HF AND MUST BE RETURNED TO BOE HF UPON ITS REQUEST



SPEC. NUMBER

PRODUCT GROUP

REV.

ISSUE DATE

PAGE

TFT- LCD

0

14 OF 29

### 3.8 LVDS Signal Timing

Table 3-10 LVDS Signal Timing

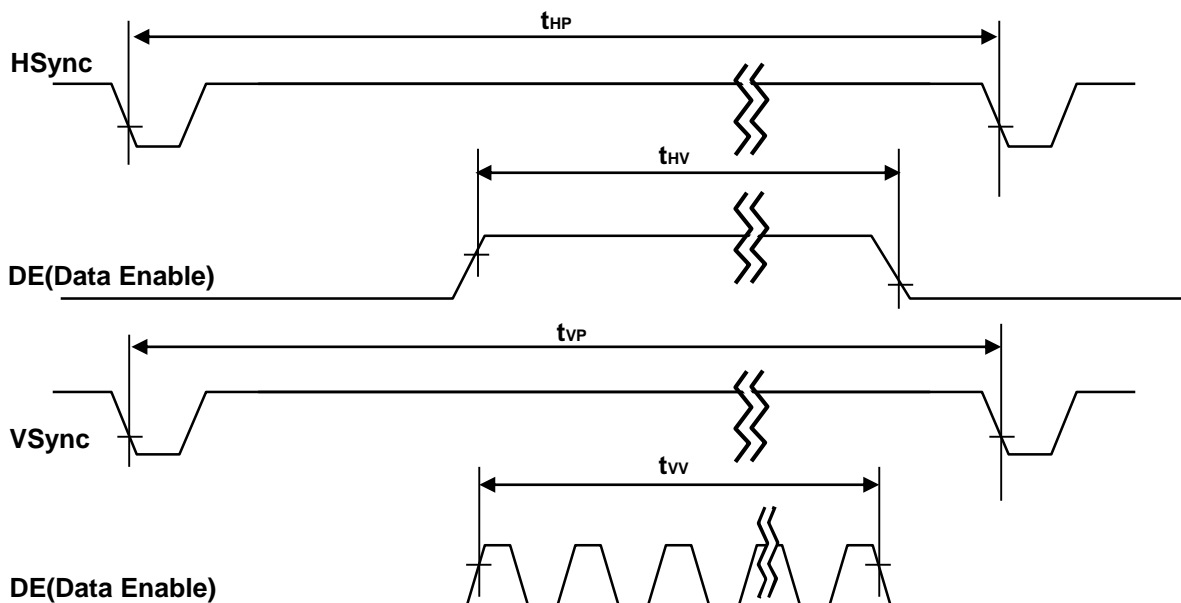
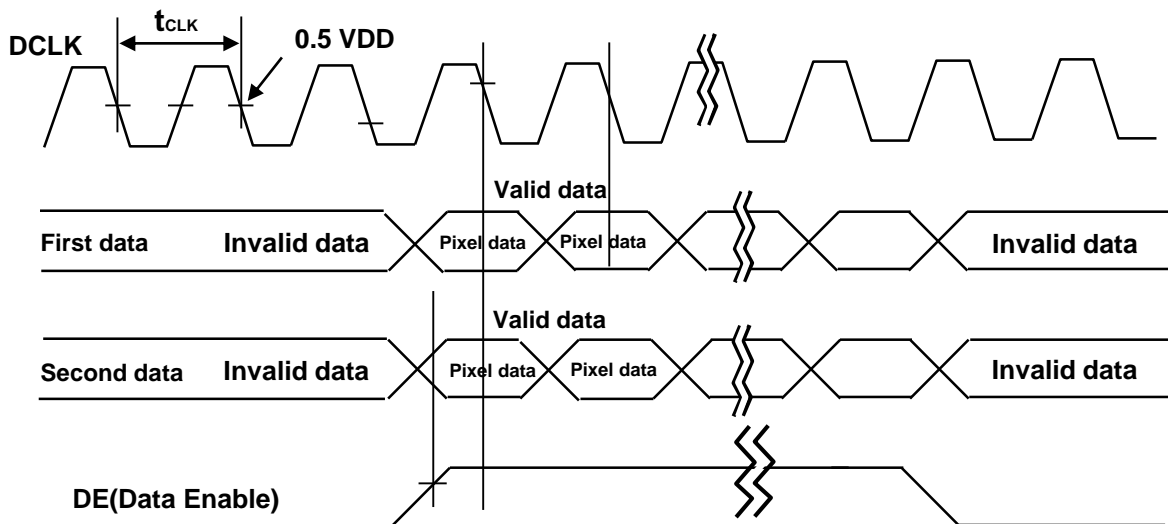

**PROPRIETARY NOTE**

THIS SPECIFICATION IS THE PROPERTY OF BOE HF AND SHALL NOT BE REPRODUCED OR COPIED WITHOUT THE WRITTEN PERMISSION OF BOE HF AND MUST BE RETURNED TO BOE HF UPON ITS REQUEST



SPEC. NUMBER

PRODUCT GROUP

REV.

ISSUE DATE

PAGE

TFT- LCD

0

15 OF 29

**3.9 LVDS Signal Timing**

Table 3-11 LVDS Signal Timing

Color & Gray Scale		Input Data Signal																							
		Red Data								Green Data				Blue Data											
		R7	R6	R5	R4	R3	R2	R1	R0	G7	G6	G5	G4	G3	G2	G1	G0	B7	B6	B5	B4	B3	B2	B1	B0
Basic Colors	Black	0	0	0	0	0	0	0	0	0	0	0	0	0	0	0	0	0	0	0	0	0	0	0	0
	Blue	0	0	0	0	0	0	0	0	0	0	0	0	0	0	0	0	1	1	1	1	1	1	1	1
	Green	0	0	0	0	0	0	0	0	1	1	1	1	1	1	1	1	0	0	0	0	0	0	0	0
	Cyan	0	0	0	0	0	0	0	0	1	1	1	1	1	1	1	1	1	1	1	1	1	1	1	1
	Red	1	1	1	1	1	1	1	1	0	0	0	0	0	0	0	0	0	0	0	0	0	0	0	0
	Magenta	1	1	1	1	1	1	1	1	0	0	0	0	0	0	0	0	1	1	1	1	1	1	1	1
	Yellow	1	1	1	1	1	1	1	1	1	1	1	1	1	1	1	1	0	0	0	0	0	0	0	0
	White	1	1	1	1	1	1	1	1	1	1	1	1	1	1	1	1	1	1	1	1	1	1	1	1
Gray Scale of Red	Black	0	0	0	0	0	0	0	0	0	0	0	0	0	0	0	0	0	0	0	0	0	0	0	0
	Δ	0	0	0	0	0	0	0	1	0	0	0	0	0	0	0	0	0	0	0	0	0	0	0	0
	Darker	0	0	0	0	0	0	1	0	0	0	0	0	0	0	0	0	0	0	0	0	0	0	0	0
	Δ																								
	▽																								
	Brighter	1	1	1	1	1	1	0	1	0	0	0	0	0	0	0	0	0	0	0	0	0	0	0	0
	▽	1	1	1	1	1	1	1	0	0	0	0	0	0	0	0	0	0	0	0	0	0	0	0	0
	Red	1	1	1	1	1	1	1	1	0	0	0	0	0	0	0	0	0	0	0	0	0	0	0	0
Gray Scale of Green	Black	0	0	0	0	0	0	0	0	0	0	0	0	0	0	0	0	0	0	0	0	0	0	0	0
	Δ	0	0	0	0	0	0	0	0	0	0	0	0	0	0	0	1	0	0	0	0	0	0	0	0
	Darker	0	0	0	0	0	0	0	0	0	0	0	0	0	0	1	0	0	0	0	0	0	0	0	0
	Δ																								
	▽																								
	Brighter	0	0	0	0	0	0	0	0	1	1	1	1	1	1	0	1	0	0	0	0	0	0	0	0
	▽	0	0	0	0	0	0	0	0	1	1	1	1	1	1	1	0	0	0	0	0	0	0	0	0
	Green	0	0	0	0	0	0	0	0	1	1	1	1	1	1	1	1	0	0	0	0	0	0	0	0
Gray Scale of Blue	Black	0	0	0	0	0	0	0	0	0	0	0	0	0	0	0	0	0	0	0	0	0	0	0	0
	Δ	0	0	0	0	0	0	0	0	0	0	0	0	0	0	0	0	0	0	0	0	0	0	0	1
	Darker	0	0	0	0	0	0	0	0	0	0	0	0	0	0	0	0	0	0	0	0	0	0	0	1
	Δ																								
	▽																								
	Brighter	0	0	0	0	0	0	0	0	0	0	0	0	0	0	0	0	1	1	1	1	1	1	0	1
	▽	0	0	0	0	0	0	0	0	0	0	0	0	0	0	0	0	1	1	1	1	1	1	1	0
	Blue	0	0	0	0	0	0	0	0	0	0	0	0	0	0	0	0	1	1	1	1	1	1	1	1
Gray Scale of White	Black	0	0	0	0	0	0	0	0	0	0	0	0	0	0	0	0	0	0	0	0	0	0	0	0
	Δ	0	0	0	0	0	0	0	1	0	0	0	0	0	0	0	1	0	0	0	0	0	0	0	1
	Darker	0	0	0	0	0	0	1	0	0	0	0	0	0	0	1	0	0	0	0	0	0	0	1	0
	Δ																								
	▽																								
	Brighter	1	1	1	1	1	1	0	1	1	1	1	1	1	1	0	1	1	1	1	1	1	1	0	1
	▽	1	1	1	1	1	1	1	0	1	1	1	1	1	1	1	0	1	1	1	1	1	1	1	0
	White	1	1	1	1	1	1	1	1	1	1	1	1	1	1	1	1	1	1	1	1	1	1	1	1

**PROPRIETARY NOTE**

THIS SPECIFICATION IS THE PROPERTY OF BOE HF AND SHALL NOT BE REPRODUCED OR COPIED WITHOUT THE WRITTEN PERMISSION OF BOE HF AND MUST BE RETURNED TO BOE HF UPON ITS REQUEST

**BOE**

SPEC. NUMBER

PRODUCT GROUP

REV.

ISSUE DATE

PAGE

TFT- LCD

0

16 OF 29

**3.10 Power on/off sequence**

Figure 3-12 Power on/off sequence

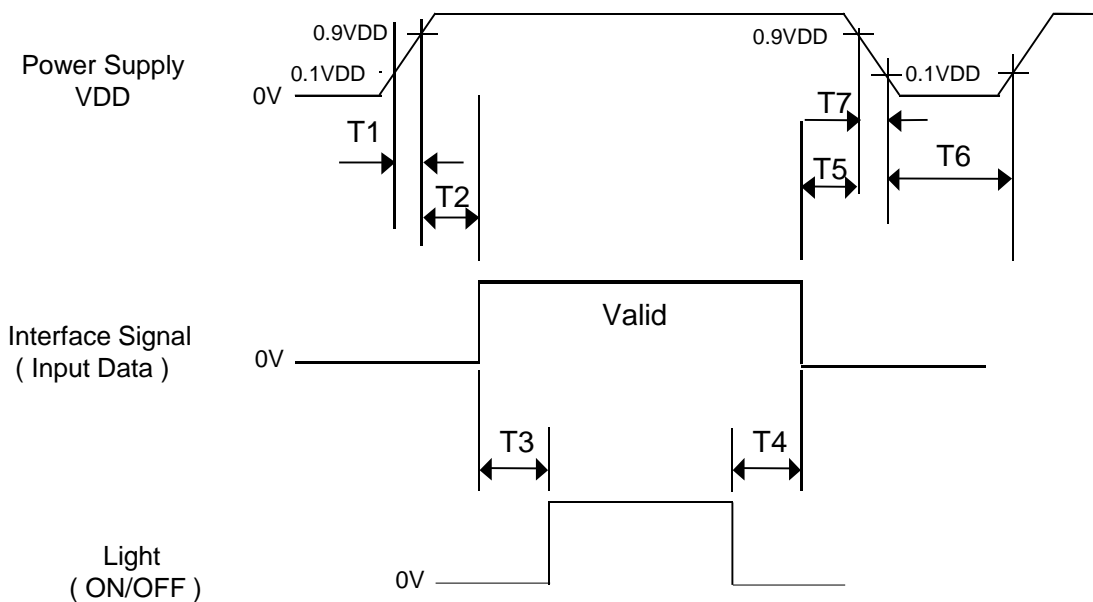

Parameter	Values			Units
	Min	Typ	Max	
T1	0.5	-	20	ms
T2	0	-	300	ms
T3	200	-	-	ms
T4	200	-	-	ms
T5	0	-	-	ms
T6	1	-	-	s



**PROPRIETARY NOTE**

THIS SPECIFICATION IS THE PROPERTY OF BOE HF AND SHALL NOT BE REPRODUCED OR COPIED WITHOUT THE WRITTEN PERMISSION OF BOE HF AND MUST BE RETURNED TO BOE HF UPON ITS REQUEST



SPEC. NUMBER	PRODUCT GROUP	REV.	ISSUE DATE	PAGE
	TFT- LCD	0		17 OF 29

## 4.0 OPTICAL SPECIFICATIONS

### 4.1 Overview

The test of Optical specifications shall be measured in a dark room (ambient luminance  $\leq 1$ lux and temperature =  $25 \pm 2^\circ\text{C}$ ) with the equipment of Luminance meter system (Goniometer system and TOPCON BM-5) and test unit shall be located at an approximate distance 15cm from the R-LCD surface at a viewing angle of  $\theta$  and  $\Phi$  equal to  $0^\circ$ , and the Incident light angle is  $30^\circ$ . The center of the measuring spot on the Display surface shall stay fixed.

Table FOB+front light (TLCM) Optical Specifications

Parameter			Symbol	Condition	Min.	Typ.	Max.	Unit	Remark
Front light off	Viewing Angle range	Horizontal	$\Theta_3$	CR > 2	-	55	-	Deg.	Note 1 Figure 4-1
			$\Theta_9$		-	55	-	Deg.	
		Vertical	$\Theta_{12}$		-	55	-	Deg.	
			$\Theta_6$		-	50	-	Deg.	
	Luminance Contrast ratio		CR	$\Theta = 0^\circ$ (Center) Normal Viewing Angle	5	10	-		Note 3 Figure 4-2
	Reflectance		NA		9	10.5	-	%	
	NTSC		%		7%	12%	-		
Front light on	Viewing Angle range	Horizontal	$\Theta_3$	CR > 2	-	50	-	Deg.	Note 7
			$\Theta_9$		-	50	-	Deg.	
		Vertical	$\Theta_{12}$		-	35	-	Deg.	
			$\Theta_6$		-	35	-	Deg.	
	Luminance Contrast ratio		CR	$\Theta = 0^\circ$ (Center) Normal Viewing Angle	5	8	-		Note 6
	brightness		NA		20	30			Note 7
	NTSC		%		5%	8%	-		Note 7

**PROPRIETARY NOTE**

THIS SPECIFICATION IS THE PROPERTY OF BOE HF AND SHALL NOT BE REPRODUCED OR COPIED WITHOUT THE WRITTEN PERMISSION OF BOE HF AND MUST BE RETURNED TO BOE HF UPON ITS REQUEST



SPEC. NUMBER

PRODUCT GROUP

REV.

ISSUE DATE

PAGE

TFT- LCD

0

18 OF 29

Parameter	Condition	Min.	Typ.	Max.	Remark
Reflectance	Θ = 0° (Center) Normal Viewing Angle	9%	10.5%	-	CM-26d

**Note :**

- Viewing angle is the angle at which the contrast ratio is greater than 10. The viewing are determined for the horizontal or 3, 9 o'clock direction and the vertical or 6, 12 o'clock direction with respect to the optical axis which is normal to the LCD surface. (See FIGURE 1 shown in Appendix)
- Contrast measurements shall be made at viewing angle of θ= 0° and at the center of the LCD surface .Reflectance shall be measured with all pixels in the view field set first to white, then to the dark (black) state. (See FIGURE 2 shown in Appendix)  
Reflectance Contrast Ratio (CR) is defined mathematically.

$$CR = \frac{\text{Reflectance when displaying a white raster}}{\text{Reflectance when displaying a black raster}}$$

- Center reflectance of white is defined as the LCD surface. Reflectance shall be measured with all pixels in the view field set first to white. This measurement shall be taken at the locations shown in FIGURE 2 for a total of the measurements per display.
- The color chromaticity coordinates specified in Table 4. shall be calculated from the spectral data measured with all pixels first in red, green, blue and white. Measurement condition is D65 source.
- The electro-optical response time measurements shall be made as FIGURE 3 shown in Appendix by switching the "data" input signal ON and OFF. The times needed for the reflectance to change from 10% to 90% is Ref, and 90% to 10% is Ref.
- Contrast measurements with front light on shall be made at viewing angle of θ= 0° and at the center of the LCD surface Luminance shall be measured with all pixels in the view field set first to white, then to the dark (black) state.

$$CR = \frac{\text{Luminance when displaying a white raster}}{\text{Luminance when displaying a black raster}}$$

**PROPRIETARY NOTE**

THIS SPECIFICATION IS THE PROPERTY OF BOE HF AND SHALL NOT BE REPRODUCED OR COPIED WITHOUT THE WRITTEN PERMISSION OF BOE HF AND MUST BE RETURNED TO BOE HF UPON ITS REQUEST



SPEC. NUMBER	PRODUCT GROUP	REV.	ISSUE DATE	PAGE
	TFT- LCD	0		19 OF 29

**7. Luminance measurement**

The test condition is at ILED=420mA and measured on the surface of LCD module at 25°C.

- The data are measured after LEDs are lighted on for more than 5 minutes and LCM displays are fully white. The brightness is the center of the LCD. Measurement equipment CS2000 or similar equipments(Field of view:1deg,Distance:50cm)
- Measuring surroundings: Dark room.
- Measuring temperature: Ta=25°C.
- Adjust operating voltage to get optimum contrast at the center of the display.
- Measured value at the center point of LCD panel must be after more than 5 minutes while backlight turning on.

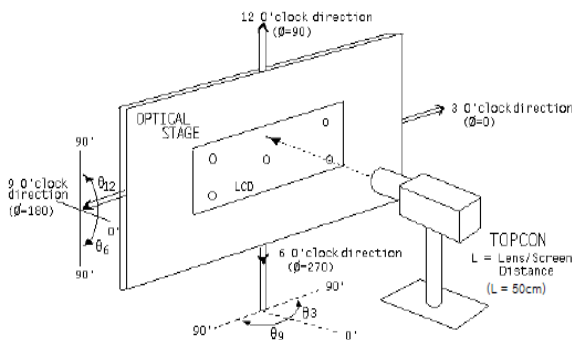

**4.2 OPTICAL TEST APPENDIX**

Figure 4-1 Reflectance View angle measurement Measurement Set Up

$$R_{\text{样品}} = \frac{I_{\text{reflective}}}{I_{\text{initial}}} \times R_{\text{标准白}} \quad R_{\text{标准白板}} \approx 98\%$$



Test Equipment: CS200  
Light Source: D65  
Light Incidence: 30°

**PROPRIETARY NOTE**

THIS SPECIFICATION IS THE PROPERTY OF BOE HF AND SHALL NOT BE REPRODUCED OR COPIED WITHOUT THE WRITTEN PERMISSION OF BOE HF AND MUST BE RETURNED TO BOE HF UPON ITS REQUEST



SPEC. NUMBER	PRODUCT GROUP TFT- LCD	REV. 0	ISSUE DATE	PAGE 20 OF 29
--------------	---------------------------	-----------	------------	------------------

Figure 4-2 Reflectance Measurement Set Up

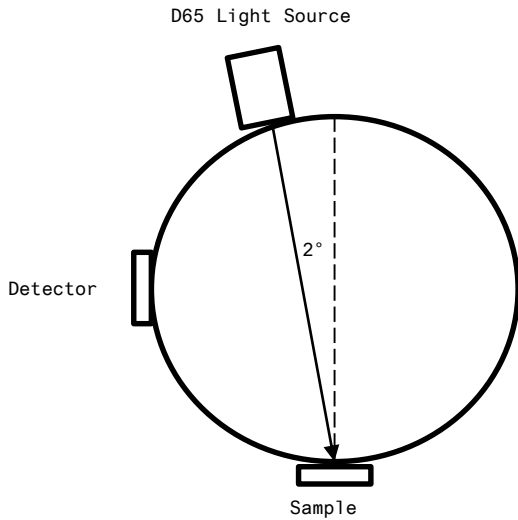

Test Equipment: CM-26D(konicaminolta)  
Light Source: D65  
Light Incidence: 2°  
Mode: SCE

Figure 4-3 Response Time Testing

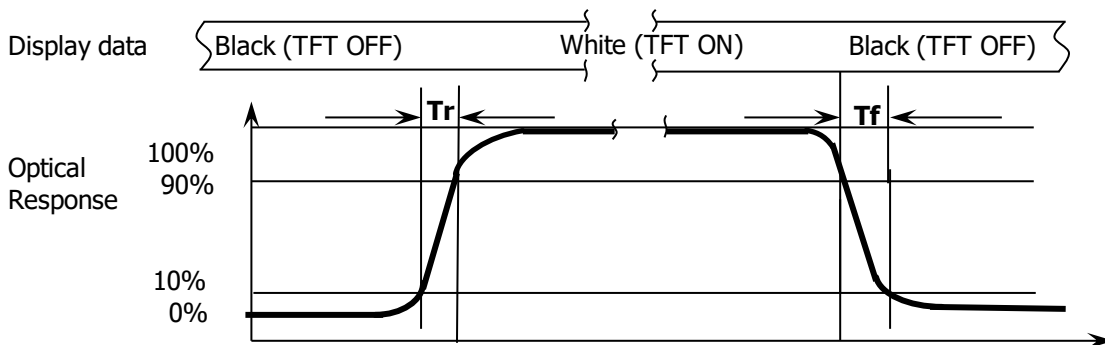

**PROPRIETARY NOTE**

THIS SPECIFICATION IS THE PROPERTY OF BOE HF AND SHALL NOT BE REPRODUCED OR COPIED WITHOUT THE WRITTEN PERMISSION OF BOE HF AND MUST BE RETURNED TO BOE HF UPON ITS REQUEST



SPEC. NUMBER

PRODUCT GROUP

REV.

ISSUE DATE

PAGE

TFT- LCD

0

21 OF 29

**5.0 MECHANICAL CHARACTERISTICS****5.1 Dimensional Requirements**

Figure in next page shows mechanical outlines for the panel.

Table 5-1 Dimensional Parameters

<b>Parameter</b>	<b>Specification</b>	<b>Unit</b>
Active Area	845.57(H)x475.63(V)	mm
Number of pixels	1920(H) × RGB × 1080(V)	Pixels
Pixel pitch	146.8 × 440.4	mm
Pixel arrangement	RGB Vertical stripe	
Display colors	16.7M	colors
Display mode	Normally White	
OC thickness	1.503 (W/O PCBA)	mm
OC outline	851.57(H)x484.63(V)(W/O PCBA)	mm
Dimensional outline	892*532*7.92	mm
AA-OC outline L/R/U/D	3/3/3/3.6	mm

**PROPRIETARY NOTE**

THIS SPECIFICATION IS THE PROPERTY OF BOE HF AND SHALL NOT BE REPRODUCED OR COPIED WITHOUT THE WRITTEN PERMISSION OF BOE HF AND MUST BE RETURNED TO BOE HF UPON ITS REQUEST



SPEC. NUMBER

PRODUCT GROUP

REV.

ISSUE DATE

PAGE  
22 OF 29

TFT- LCD

0

**5.2 Outline(Front view)**

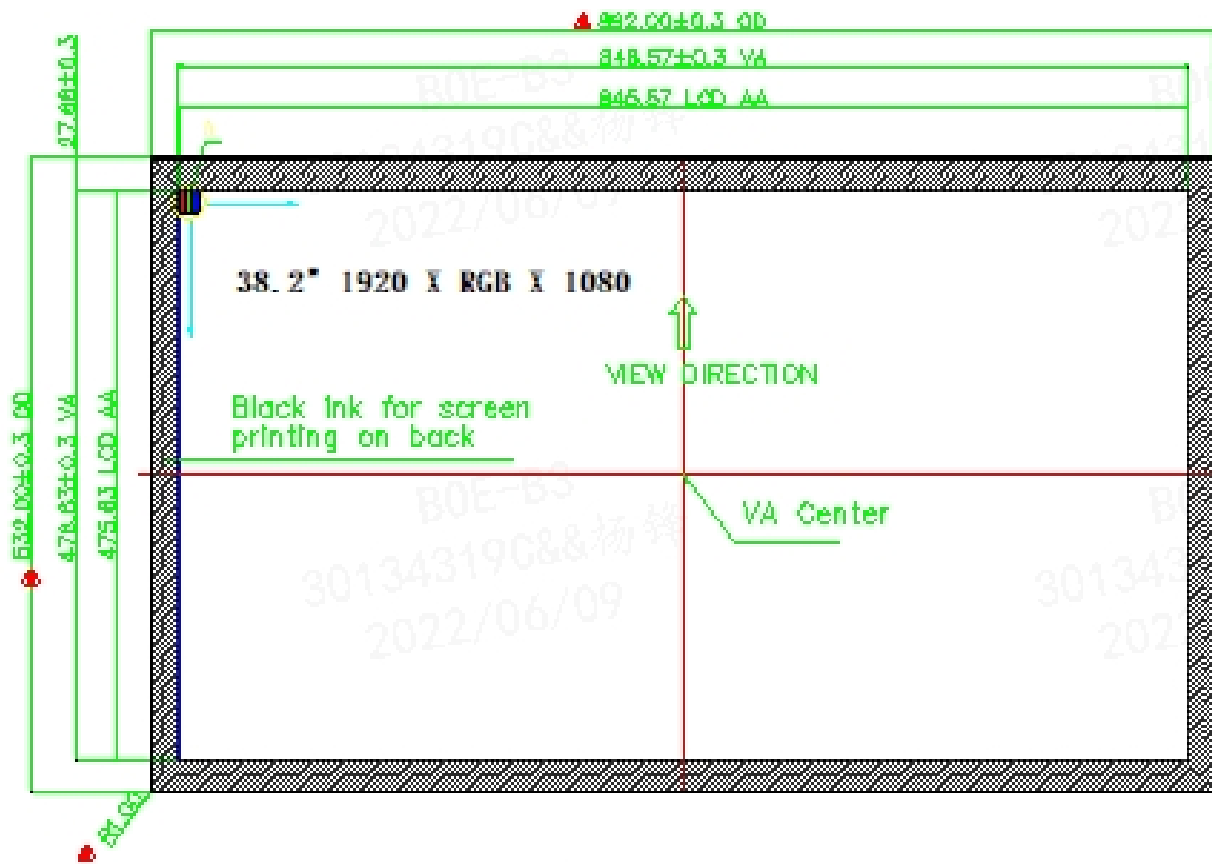

**PROPRIETARY NOTE**

THIS SPECIFICATION IS THE PROPERTY OF BOE HF AND SHALL NOT BE REPRODUCED OR COPIED WITHOUT THE WRITTEN PERMISSION OF BOE HF AND MUST BE RETURNED TO BOE HF UPON ITS REQUEST



SPEC. NUMBER

PRODUCT GROUP

REV.

ISSUE DATE

PAGE

TFT- LCD

0

23 OF 29

**5.2 Outline(Back view)**

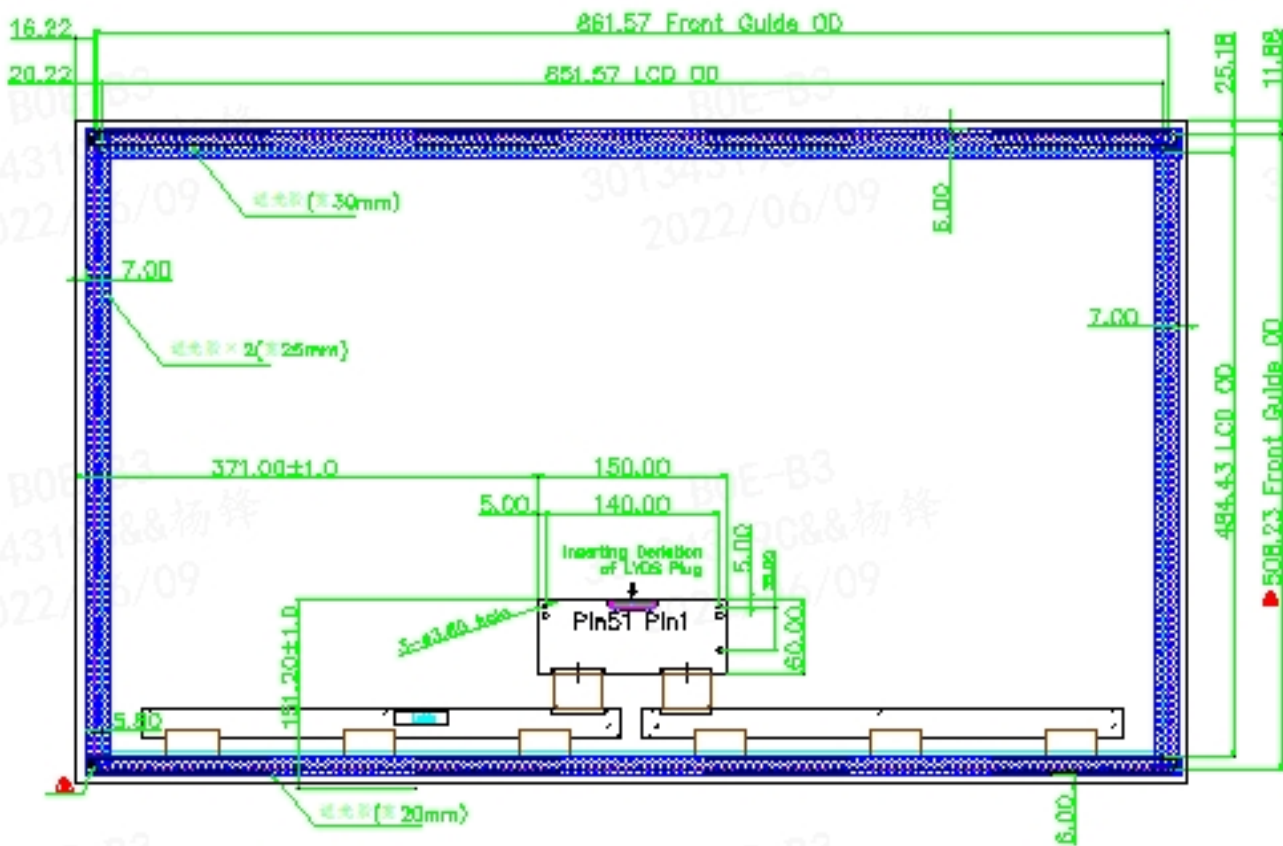

**PROPRIETARY NOTE**

THIS SPECIFICATION IS THE PROPERTY OF BOE HF AND SHALL NOT BE REPRODUCED OR COPIED WITHOUT THE WRITTEN PERMISSION OF BOE HF AND MUST BE RETURNED TO BOE HF UPON ITS REQUEST



SPEC. NUMBER

PRODUCT GROUP

REV.

ISSUE DATE

PAGE  
24 OF 29

TFT- LCD

0

### 5.3 Front Light Diagram

FRONT LIGHT CIRCUIT:  
2EA FRONT LIGHT BAR,  
LED QTY/EA: 12\*21=252PCS  
Vf=34--36V , If=21\*20=420mA (参考)

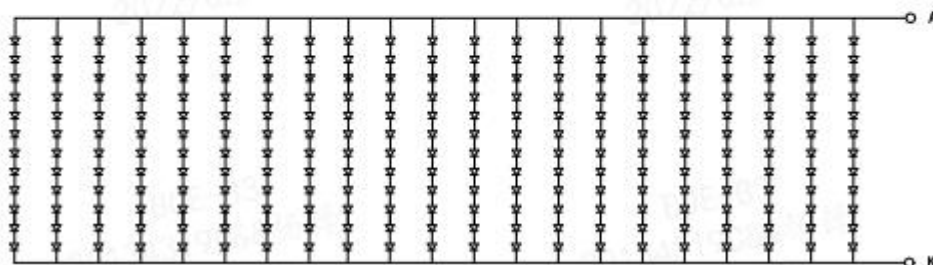

单个前光模组用量为2，飞线50mm，插接头为TX60公口



**PROPRIETARY NOTE**

THIS SPECIFICATION IS THE PROPERTY OF BOE HF AND SHALL NOT BE REPRODUCED OR COPIED WITHOUT THE WRITTEN PERMISSION OF BOE HF AND MUST BE RETURNED TO BOE HF UPON ITS REQUEST

**BOE**

SPEC. NUMBER

PRODUCT GROUP

REV.

ISSUE DATE

PAGE

TFT- LCD

0

25 OF 29

**6.0 RELIABILITY**

Table 6-1 Reliability test

No	Test Items	Conditions	Remark
1	High temperature storage test	Ta = 80 °C, 240 hrs	
2	Low temperature storage test	Ta = -30 °C, 240 hrs	
3	High temperature operation test	Ta = 70 °C, 240 hrs	
4	Low temperature operation test	Ta = -20 °C, 240 hrs	
5	High temperature & high humidity operation test	Ta = 60 °C, 90%RH, 240 hrs	
6	Thermal shock	Ta = -40 °C ↔ 85°C (0.5 hr), 100 cycle	Storage
7	Image Sticking	7*5 Checkerboard,1H, 25°C;Inspection Pattern:50% grey; ≤Lv2, After 5 mins, the image sticking must be disappeared completely	
8	ESD test	Air Voltage:±8KV Contact Voltage:±4KV R: 1.5kΩ C: 100pF CLASSB	
9	Vibration Test	Random:1.47 Grms Hz, 5~200Hz XYZ 1H	

Note: After the reliability test, the product only guarantee function normally without any fatal defect (non-display, line defect, abnormal display etc ). All the cosmetic specification is judged before the reliability test.

**PROPRIETARY NOTE**

THIS SPECIFICATION IS THE PROPERTY OF BOE HF AND SHALL NOT BE REPRODUCED OR COPIED WITHOUT THE WRITTEN PERMISSION OF BOE HF AND MUST BE RETURNED TO BOE HF UPON ITS REQUEST



SPEC. NUMBER

PRODUCT GROUP

REV.

ISSUE DATE



PAGE

TFT- LCD

0

26 OF 29

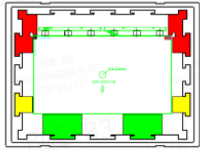
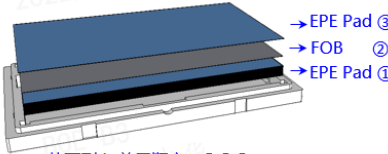
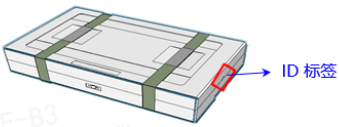
## 7.0 Packing

<p>将挡块和干燥剂放到Bottom的相应位置。 BOX与滑块比例1:2:2:2 2ea 干燥剂/BOX (挡块和干燥剂放置说明详见Appendix)</p>	<p>将EPE Pad、FOB依次放入Box 9 EPE Pad/Box, 8Pcs FOB/Box</p>	<p>将Box扣合, 用2条捆绑带捆绑, 并粘贴ID标签。</p>
 <p style="text-align: right;"><b>Step 1</b></p>	 <p style="text-align: center;">从下到上 放置顺序: ①②③</p> <p style="text-align: right;"><b>Step 2</b></p>	 <p style="text-align: right;"><b>Step 3</b></p>
<p>7BOX/Pallet 在整拍四周放护角, pallet长方向捆绑两道打包带, 并粘贴Pallet标签, 缠绕拉伸膜, 层数不少于3层。 (除底面外的5个面需全部覆盖) 56 pcs FOB /Pallet</p>	<p>厢车装载方式: 一横一竖双层码放 厢车装载量_12m: 2576pcs (46托)</p>	
 <p style="text-align: right;"><b>Step 4</b></p>	 <p style="text-align: right;"><b>Step 5</b></p>	

**PROPRIETARY NOTE**

THIS SPECIFICATION IS THE PROPERTY OF BOE HF AND SHALL NOT BE REPRODUCED OR COPIED WITHOUT THE WRITTEN PERMISSION OF BOE HF AND MUST BE RETURNED TO BOE HF UPON ITS REQUEST



SPEC. NUMBER	PRODUCT GROUP TFT- LCD	REV. 0	ISSUE DATE	PAGE 27 OF 29
--------------	---------------------------	-----------	------------	------------------

## 8.0 PRODUCT SERIAL NUMBER

### 8.1 Module ID

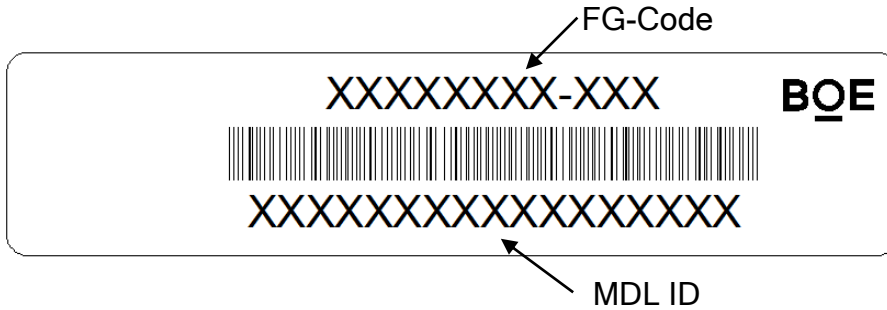

#### Module ID编码原则

Digit	1	2	3	4	5	6	7	8	9	10	11	12	13	14	15	16	17
Code	S	L	S	A	1	0	8	5	9	4	2	0	0	0	1	D	B
Description	Product Code/GBN → FG-CODE ——对应		Grade	line	Year	Month	Model Extension Code (Last 4 Digits of FG-CODE)				Serial No. Hex-Decimal 000000-FFFFFF						

### 8.2 Box ID

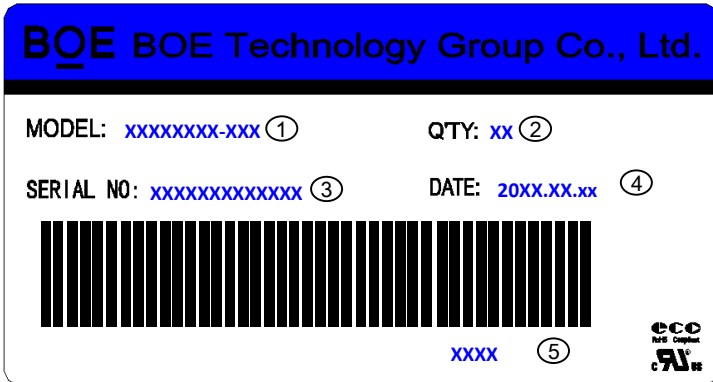

打印内容, 说明如下:

- ① FG-CODE
- ② 产品数量
- ③ Box ID, 编码规则如下
- ④ Box Packing 日期
- ⑤ 产品物料号(客户端)
- ⑥ FG-CODE 后四位+Grade

#### BOX ID编码原则

Digit	1	2	3	4	5	6	7	8	9	10	11	12	13
Code	S	L	S	A	1	6	3	D	0	0	1	A	1
Description	Products GBN		Grade	Line	Year	Month	Revision Code	Serial No.					

**PROPRIETARY NOTE**

THIS SPECIFICATION IS THE PROPERTY OF BOE HF AND SHALL NOT BE REPRODUCED OR COPIED WITHOUT THE WRITTEN PERMISSION OF BOE HF AND MUST BE RETURNED TO BOE HF UPON ITS REQUEST



SPEC. NUMBER

PRODUCT GROUP

REV.

ISSUE DATE

PAGE  
28 OF 29

TFT- LCD

0

**8.3 Pallet ID**

**FG-CODE** xxxxxxxx-xxx.xxxx ①  
**QTY :**        xxxx ②  
**DATE :**        xxxx/xx/xx ③        x ④  
PALLET ID 条形码        (QA) ⑥  
**PALLET :**        xxxxxxxxxxxx ⑤

**打印内容, 说明如下**

FG-CODE: GT382FHB-N10-DMQ0

- ① Pallet 产品数量
- ② Pallet Packing 日期
- ③ E:Export (出口) D:Domain (内销)
- ④ Pallet ID, 编码规则如下
- ⑤ QA检查标志

**通用Pallet ID编码原则**

Digit	1	2	3	4	5	6	7	8	9	10	11	12
Code	2	0	1	6	3	A	M	0	0	5	6	7
Description	Year				Month	Line	Pallet 方式	Serial No.				

**PROPRIETARY NOTE**

THIS SPECIFICATION IS THE PROPERTY OF BOE HF AND SHALL NOT BE REPRODUCED OR COPIED WITHOUT THE WRITTEN PERMISSION OF BOE HF AND MUST BE RETURNED TO BOE HF UPON ITS REQUEST



SPEC. NUMBER

PRODUCT GROUP

REV.

ISSUE DATE

PAGE

TFT- LCD

0

29 OF 29

## 9.0 PRECAUTIONS

### 9.1 Handling

- (1) Use fingerstalls with soft gloves in order to keep display clean during the incoming inspection and assembly process.
- (2) You must mount a module using specified mounting holes (Details refer to the drawings).
- (3) Please make sure to avoid external forces applied to the Source PCB or FPC and D-IC during the process of handling or assembling. If not, It causes panel damage or malfunction.
- (4) Note that polarizers are very fragile and could be easily damaged. Do not touch, push or rub the exposed polarizers with glass, tweezers or anything harder than HB pencil lead. And please do not rub with dust clothes with chemical treatment.
- (5) Do not pull or fold the source D-IC which connect the source PCB or FPC and the panel. Do not pull or fold the LED wire.
- (6) After removing the protective film, when the surface becomes dusty, please wipe gently with absorbent cotton or other soft materials like chamois soaks with alcohol or purified water. Do not strong polar solvent because they cause chemical damage to the polarizer
- (7) Wipe off saliva or water drops as soon as possible. Their long time contact with . polarizer causes deformations and color fading.
- (8) Protection film for polarizer on the module shall be slowly peeled off just before use so that the electrostatic charge can be minimized.
- (9) Since the LCD is made of glass, do not apply strong mechanical impact or static load onto it. Handling with care since shock, vibration, and careless handling may seriously affect the product. If it falls from a high place or receives a strong shock, the glass may be broken.
- (10) Do not disassemble the module.
- (11) To determine the optimum mounting angle, refer to the viewing angle range in the specification for each model.
- (12) If the customer's set presses the main parts of the LCD, the LCD may show the abnormal display. But this phenomenon does not mean the malfunction of the LCD and should be pressed by the way of mutual agreement.
- (13) Do not drop water or any chemicals onto the LCD's surface.
- (14) The ITO pad area needs special careful caution because it could be easily corroded. Do not contact the ITO pad area with HCFC, Soldering flux, Chlorine, Sulfur, saliva or fingerprint. To prevent the ITO corrosion, customers are recommended that the ITO area would be covered by UV or silicon.

**PROPRIETARY NOTE**

THIS SPECIFICATION IS THE PROPERTY OF BOE HF AND SHALL NOT BE REPRODUCED OR COPIED WITHOUT THE WRITTEN PERMISSION OF BOE HF AND MUST BE RETURNED TO BOE HF UPON ITS REQUEST



SPEC. NUMBER

PRODUCT GROUP

REV.

ISSUE DATE

PAGE

TFT- LCD

0

30 OF 29

## 9.2 Operating Precautions

- (1) Be careful for condensation at sudden temperature change. Condensation makes damage to polarizer or electrical contacted parts. And after fading condensation, smear or spot will occur.
- (2) Module has high frequency circuits. Sufficient suppression to the electromagnetic interference shall be done by system manufacturers. Grounding and shielding methods may be important to minimized the interference.
- (3) The electrochemical reaction caused by DC voltage will lead to LCD degradation, so DC drive should be avoided.
- (4) The LCD modules use C-MOS LSI drivers, so customers are recommended that any unused input terminal would be connected to Vdd or Vss, do not input any signals before power is turn on, and ground you body, work/assembly area, assembly equipments to protect against static electricity.
- (5) Do not exceed the absolute maximum rating value. (supply voltage variation, input voltage variation, variation in part contents and environmental temperature, and so on) Otherwise the Module may be damaged.
- (6) Connectors are precise devices for connecting PCB and transmitting electrical signals. Operators should insert and unplug MDL in parallel when assembling MDL.
- (7) Do not connect or disconnect the cable to/ from the module at the "Power On" condition.
- (8) When the module is operating, do not lose CLK, HS, VS signals. If any one these signals is lost, the LCD panel would be damaged.
- (9) Obey the supply voltage sequence. If wrong sequence is applied, the module would be damaged.
- (10) Do not re-adjust variable resistor or switch etc.

**PROPRIETARY NOTE**

THIS SPECIFICATION IS THE PROPERTY OF BOE HF AND SHALL NOT BE REPRODUCED OR COPIED WITHOUT THE WRITTEN PERMISSION OF BOE HF AND MUST BE RETURNED TO BOE HF UPON ITS REQUEST



SPEC. NUMBER

PRODUCT GROUP

REV.

ISSUE DATE

PAGE

TFT- LCD

0

31 OF 29

### 9.3 Electrostatic Discharge Control

- (1) Since a module is composed of electronic circuits, it is not strong to electrostatic discharge. Make certain that treatment persons are connected to ground through wrist band etc. And don't touch interface pin directly. Keep products as far away from static electricity as possible.
- (2) Avoid the use work clothing made of synthetic fibers. We recommend cotton clothing or other conductivity-treated fibers.

### 9.4 Precautions for Strong Light Exposure

Strong light exposure causes degradation of polarizer and color filter. It is not allowed to store or run directly in strong light or in high temperature and humidity for a long time.

### 9.5 Storage Precautions

- (1) When storing the LCD modules, avoid exposure to direct sunlight or to the light of fluorescent lamps.
- (2) The LCD modules should be stored under the storage temperature range. the recommend condition is: Temperature : 0°C~ 40°C, Relatively humidity: ≤80%, and no more than 1 year.
- (3) The LCD modules should be stored in the room without acid, alkali and harmful gas.

### 9.6 Handling Precautions for Protection Film (不适用于Q/Single出货产品)

- (1) Remove the protective film slowly, keeping the removing direction approximate 30-degree not vertical from panel surface, If possible, under ESD control device like ion blower, and the humidity of working room should be kept over 50%RH to reduce the risk of static charge.
- (2) In handling the LCD, wear non-charged material gloves. And the conducting wrist to the earth and the conducting shoes to the earth are necessary.

### 9.7 Operation Condition Guide

- (1) Lifetime in this spec. is guaranteed only when Commercial Display is used according to operating usages.
- (2) Module used in unnormal orientation mode, need to confirm with the manufacturer.
- (3) Do not exceed the absolute maximum rating value. (supply voltage variation, input voltage variation, variation in part contents and environmental temperature, and so on) Otherwise the Module may be damaged.

**PROPRIETARY NOTE**

THIS SPECIFICATION IS THE PROPERTY OF BOE HF AND SHALL NOT BE REPRODUCED OR COPIED WITHOUT THE WRITTEN PERMISSION OF BOE HF AND MUST BE RETURNED TO BOE HF UPON ITS REQUEST



SPEC. NUMBER

PRODUCT GROUP

REV.

ISSUE DATE

PAGE

TFT- LCD

0

32 OF 29

- (4) Dew drop atmosphere should be avoided.
- (5) The storage room should be equipped with a good ventilation facility, which has a temperature controlling system.
- (6) When expose to drastic fluctuation of temperature (hot to cold or cold to hot) ,the LCD may be affected; Specifically, drastic temperature fluctuation from cold to hot ,produces dew on the LCD's surface which may affect the operation of the polarizer and the LCD.
- (7) Response time will be extremely delayed at lower temperature than the operating temperature range and on the other hand at higher temperature LCD may turn black at temperature above its operational range. However those phenomena do not mean malfunction or out of order with the LCD. The LCD will revert to normal operation once the temperature returns to the recommended temperature range for normal operation.

9.8 Others

- (1)When returning the module for repair or etc., Please pack the module not to be broken. We recommend to use the original shipping packages.
- (2) In order to prevent potential problems, flicker should be adjusted by optimizing the Vcom value in customer LCM. (适用于Q panel/single/OC出货)
- (3) If the liquid crystal material leaks from the panel, it should be kept away from the eyes or mouth. In case of contact with hands, legs or clothes, it must be washed away thoroughly with soap.
- (4) For the crash damaged or unnecessary LCD, it is recommended to wash off liquid crystal by either of solvents such as acetone and ethanol and should be burned up later.
- (5) If you should swallow the liquid crystal, first, wash your mouth thoroughly with water, then drink a lot of water and induce vomiting, and then, consult a physician.
- (6) If the liquid crystal should get in your eyes, flush your eyes with running water for at least fifteen minutes.
- (7) Client needs to add heat dissipation design , such as fan, water cooling , etc.
- (8) After assembling into modules, guarantee that the temperature rise of panel surface does not exceed 20 C at room temperature.
- (9) Customers need to drive current down according to derating curve.