

MODEL NO. : TM116VDSP01

MODEL VERSION: 00

SPEC VERSION: 2.0

ISSUED DATE: 2018-10-9

- Preliminary Specification
- Final Product Specification

Customer : Garmin

Approved by	Notes

TIANMA Confirmed :

Prepared by	Checked by	Approved by
Tiantian Zhao	Xiaoxing Ding	Kevin Kim

Table of Contents

1 General Specification.....	4
2. Input/output Terminals	5
3.Absolute Maximum Ratings	7
4.Electrical Characteristics	8
5.Timing Chart.....	10
6. Optical Characteristics.....	14
7 Environmental / Reliability Test	17
8 Mechanical Drawing	18
9. Packaging Material	19
10. Precautions for Use of LCD Modules.....	21

Record of Revision

Rev	Issued Date	Description	Editor
1.0	2017-12-06	Preliminary Specification release	Tiantian Zhao
1.1	2017-12-11	1.Change note at P5(the note is as same sa NLT15.6) 2.Change pin description at P6 (there was a clerical error at last versions) 3.Add more details in BLU description at P8. 4.Update NTSC min as 65% at P12. 5.Change top bezel open location in 2D drawing at P16. Modify note 4&5 in 2D drawing at P16. 6.Change LED FPC connector as Garmin's requirement at P16. 7.Update LED Numbers as 48LED at P4	Tiantian Zhao
1.2	2017-12-15	1.Update TFT Block Diagram at P9. 2.modify the Screw position at 2D drawing	Tiantian Zhao
1.3	2017-12-29	1.Update the LED-FPC length in 2D drawing at P16 2.update barcode at P20	Tiantian Zhao
1.4	2018-1-04	Update more data input at P9,P12	Tiantian Zhao
1.5	2018-1-20	1.Correct connector at 2D drawing 2. Update Data input format at P12	Tiantian Zhao
1.6	2018-4-20	1. Update 2D drawing; 2. Add AVDD,AGH,AGL in spec 3. Add Optical Characteristics	Tiantian Zhao
1.7	2018-6-6	1. Add more details at P8; 2. Update 2D drawing; 3. Update package; 4. Update Optical Characteristics at P15.	Tiantian Zhao
1.8	2018-8-26	Update LED current to 40mA	Tiantian Zhao
1.9	2018-10-9	Correct some typing error	Tiantian Zhao
2.0	2018-10-9	FINAL Specification release	Tiantian Zhao
2.1	2018-11-22	Update power consumption in flicker pattern	Lingjie Li

1 General Specification

Item	Feature	Spec
Display spec	Size	11.6 inch
	Resolution	1920(RGB) x 1080
	Interface	LVDS
	Color Depth	16M
	Technology Type	a-Si
	Pixel Pitch	133.5um*133.5um
	Pixel Configuration	R.G.B. Vertical Stripe
	Display Mode	TM with Normally black
	Surface Treatment(Up Polarizer)	HC
	Viewing Direction	All angle
	Gray Scale Inversion Direction	All angle
	LCM (W x H x D)	273.50X166.50X7.8
	Drive IC	TFT:NT51625+NT52601
Mechanical Characteristics	TFT Active Area	256.32 x 144.18
	Matching Connection Type	Plug: IPEX 20453-230T-11 Socket :IPEX 20455-030E-76
	LED Numbers	48 LEDs
	Weight	527g
Electrical Characteristics	Operation temperature	-20~80
	Storage temperature	-30~85

Note 1: Viewing direction for best image quality is different from Gray Scale Inversion Direction, there is a 180 degree shift.

Note 2: Requirements on Environmental Protection: Q/S0002

Note 3: LCM weight tolerance: ± 5%ght toler

Note 4 : Polarizer absorption angle pattern :

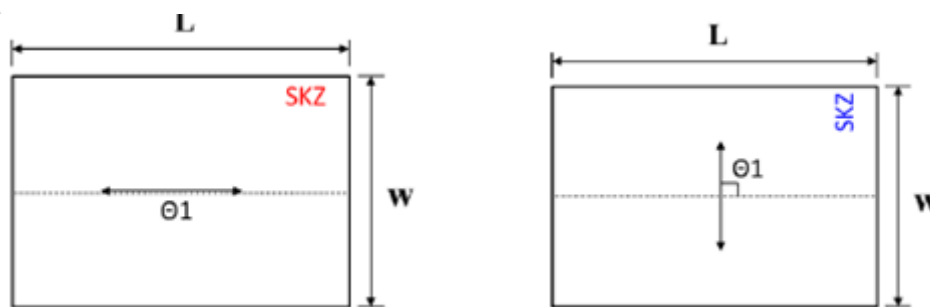

Top Polarizer

Bottom Polarizer

Top view from Protective Film side

The information contained herein is the exclusive property of TIANMA MICRO-ELECTRONICS Corporation, and shall not be distributed, reproduced, or disclosed in whole or in part without prior written permission of TIANMA MICRO-ELECTRONICS Corporation.

2. Input/output Terminals

2.1 INPUT TERMINALS PIN ASSIGNMENT

Matched Connector: Plug: IPEX 20453-230T-11
Socket :IPEX 20455-030E-76

Pin No.	Symbol	I/O (Note1)	Description	Comment
1	DA0-	I	Odd pixel data 0	Note1
2	DA0+	I	Odd pixel data 0	Note1
3	DA1-	I	Odd pixel data 1	Note1
4	DA1+	I	Odd pixel data 1	Note1
5	DA2-	I	Odd pixel data 2	Note1
6	DA2+	I	Odd pixel data 2	Note1
7	GND	P	Ground	Note2
8	CLKA-	I	Odd pixel clock	Note1
9	CLKA+	I	Odd pixel clock	Note1
10	DA3-	I	Odd pixel data 3	Note1
11	DA3+	I	Odd pixel data 3	Note1
12	DB0-	I	Even pixel data 0	Note1
13	DB0+	I	Even pixel data 0	Note1
14	GND	P	Ground	Note2
15	DB1-	I	Even pixel data 1	Note1
16	DB1+	I	Even pixel data 1	Note1
17	GND	P	Ground	Note2
18	DB2-	I	Even pixel data 2	Note1
19	DB2+	I	Even pixel data 2	Note1
20	CLKB-	I	Even pixel clock	Note1
21	CLKB+	I	Even pixel clock	Note1
22	DB3-	I	Even pixel data 3	Note1
23	DB3+	I	Even pixel data 3	Note1
24	GND	P	Ground	Note2
25	GND	P	Ground	Note2
26	GND	P	Ground	Note2
27	GND	P	Ground	Note2
28	VCC	P	Power supply	Note2
29	VCC	P	Power supply	Note2
30	VCC	P	Power supply	Note2

Note 1: twist pair wires with 100 Ω (characteristic impedance) should be used between LCD panel signal processing board and LVDS transmitter.

Note 2: ALL GND and VCC terminals should be used without any non-connected lines.

2.2 Backlight PIN ASSIGNMENT

Matched Connector: Kyocera 04 6299 614 020 846+

Pin No.	Symbol	I/O (Note1)	Description	Comment
1	A1	P	Anode 1	Anode 1&2 must be separate from Anode 3&4 on the LED board.
2	A2	P	Anode 2	
3	A3	P	Anode 3	
4	A4	P	Anode 4	
5	NC	-	~	-
6	NC	-	~	-
7	K1	P	Cathode 1	-
8	K2	P	Cathode 2	-
9	K3	P	Cathode 3	-
10	K4	P	Cathode 4	-
11	K5	P	Cathode 5	-
12	K6	P	Cathode 6	-
13	K7	P	Cathode 7	-
14	K8	P	Cathode 8	-

3. Absolute Maximum Ratings

 $T_a = 25^{\circ}\text{C}$

Item	Symbol	Min	Max	Unit	Remark
Power Voltage	VCC	-0.5	5	V	Note1
Operating Temperature	TOPR	-20	80	$^{\circ}\text{C}$	Note2
Storage Temperature	TSTG	-30	85	$^{\circ}\text{C}$	
Relative Humidity Note2	RH	--	≤ 85	%	$40^{\circ}\text{C} < T_a \leq 50^{\circ}\text{C}$
		--	≤ 55	%	$50^{\circ}\text{C} < T_a \leq 60^{\circ}\text{C}$
		--	≤ 36	%	$60^{\circ}\text{C} < T_a \leq 70^{\circ}\text{C}$
		--	≤ 24	%	$70^{\circ}\text{C} < T_a \leq 80^{\circ}\text{C}$
Absolute Humidity	AH	--	≤ 70	g/m^3	$T_a > 70^{\circ}\text{C}$

Table 3.1 absolute maximum rating

Note1: The parameter is for driver IC (gate driver, source driver) only

Note2: T_a means the ambient temperature.

It is necessary to limit the relative humidity to the specified temperature range.

Condensation on the module is not allowed.

4. Electrical Characteristics

4.1 Driving TFT LCD Panel

Ta = 25°C

Parameter	Symbol	min.	typ.	max.	Unit	Remarks
Power supply voltage	VCC	3.0	3.3	3.6	V	-
Power supply current	ICC (White pattern)		480	552	mA	at VCC=3.3V reduce SD Film thickness
Permissible ripple voltage	VRP	-	-	300	mVp-p	for VCC
Power For Analog Circuit	AVDD	10.5	10.7	10.9	V	
Gate On Voltage	VGH	19	20	21	V	
Gate Off Voltage	VGL	-6.5	-7.0	-7.5	V	
Terminating resistance	RT	-	100	-	Ω	-
(Panel+LSI) Power Consumption	White Mode (60Hz)		1584	1821	mW	reduce SD Film thickness
Power Consumption	Flicker Mode (60Hz)		270	310	mW	reduce SD Film thickness

Table 4.1 LCD module electrical characteristics

Note: Power supply current and Power Consumption are just for reference because of limited test samples, we may update slightly when output final spec.

4.2 TFT Driving Backlight

Ta=25°C

Item	Symbol	MIN	TYP	MAX	Unit	Remark
Forward Current(per string)	I _F	—	40	—	mA	48LED(6LED Serial, 8LED Parallel)
Forward Current Voltage (per string)	V _F	—	36.6	—	V	
Backlight Power Consumption	W _{BL}	—	11712	—	mW	
LED life time		10000	30000		hour	
LED supplier	NF2W257HRT					

Table 4.2 Backlight Unit Electrical Characteristics

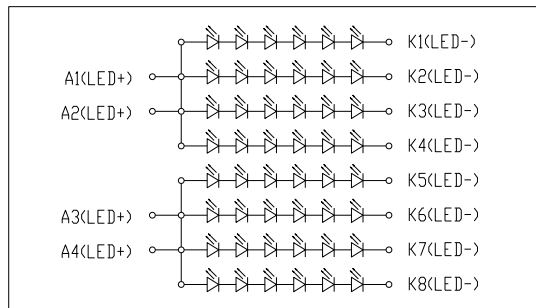

Backlight Circuit Diagram
Figure 4.2.1 LED Driver Circuit

4.3 TFT Block Diagram

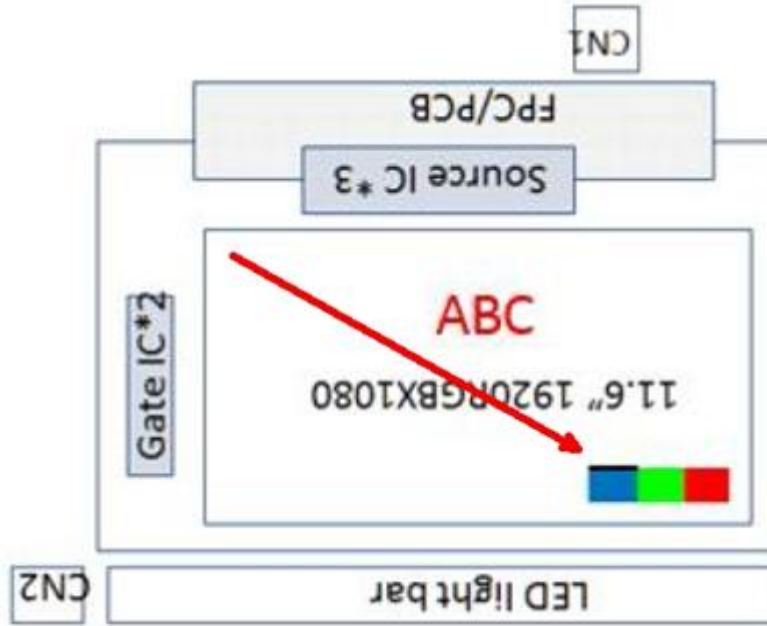

4.4 Location Setting for Gate Driver

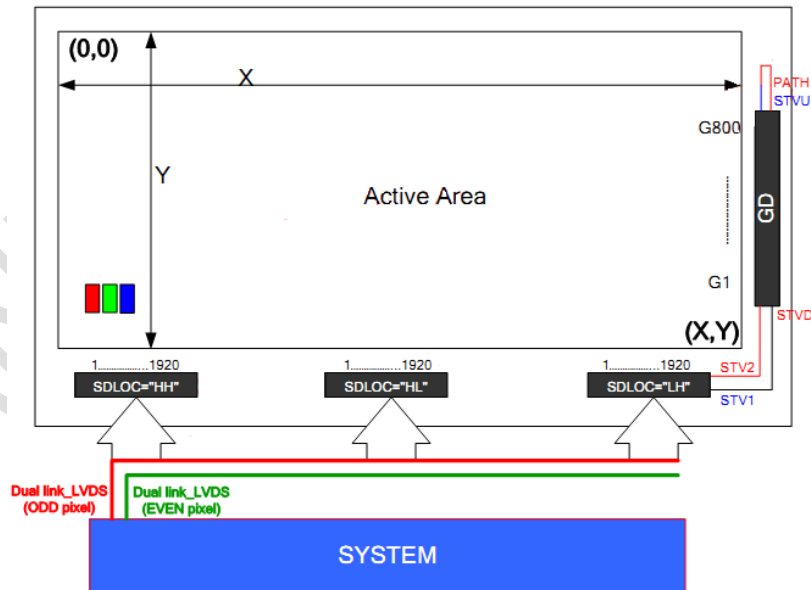

Location For Source Driver

Note: In Dual-Link LVDS mode: The first pixel on panel(top-left) is odd.

5. Timing Chart

5.1 LVDS Interface DC Characteristics

Parameter	Symbol	Min.	Typ.	Max.	Unit	Condition
Differential input high threshold voltage	R_{xVTH}	-	-	+200	mV	
Differential input low threshold voltage	R_{xVTL}	-200	-	-	mV	
Differential input common mode voltage	R_{xVCM}	1.0	1.2	$1.7 - V_{ID} /2$	V	
Differential input voltage	$ V_{ID} $	200	-	600	mV	
Input Terminal Resistance tolerance	R_{TERM}	-20%	-	+20%	%	$R_{TERM}[2:0] \neq "HHH"$
Differential input leakage current	I_{xVLEK}	-10	-	+10	μA	$V_{CC_IF}=1.8V$, $CLKP/N, DxP/N$ $R_{TERM}[2:0] = "HHH"$
LVDS Digital Stand-by current	I_{xVST}	-	-	150	mA	$V_{CC_IF}=1.8V$, Clock & all functions are stopped, $STBYB = L$
LVDS Digital Operating current	I_{xVOP}	-	-	40	μA	$V_{CC_IF}=1.8V$, $F_{CLK} = 85MHz$, Data pattern: 55h→AAh→55h→AAh

Single-end Signal

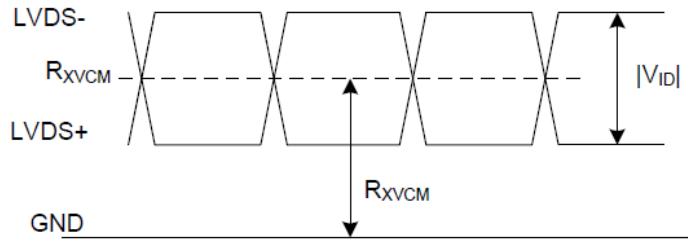

Differential Signal

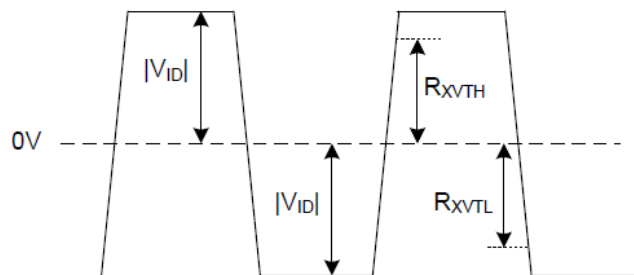

Figure 5.1 LVDS DC Diagram

5.2 AC characteristics

Parameter	Symbol	Min.	Typ.	Max.	Unit	Condition
Clock frequency	FLVCLK	25	-	85	MHz	Refer to input timing table for each display resolution.
Clock Period	TLVCLK	40	-	11.76	nsec	
Clock high time	TLVCH	-	$4/(7 * RXFCLK)$	-	ns	
Clock low time	TLVCL	-	$3/(7 * RXFCLK)$	-	ns	
Input data skew margin	TRSKM	-	-	0.25	UI	VCC_IF=1.8V w/o SSC
Strobe width	TSW	0.5	-	-	UI	
1 data bit time	UI	-	1/7	-	TLV CLK	
Position 1	TPOS1	-0.25	0	0.25	UI	
Position 0	TPOS0	0.75	1	1.25	UI	
Position 6	TPOS6	1.75	2	2.25	UI	
Position 5	TPOS5	2.75	3	3.25	UI	
Position 4	TPOS4	3.75	4	4.25	UI	
Position 3	TPOS3	4.75	5	5.25	UI	
Position 2	TPOS2	5.75	6	6.25	UI	
PLL wake-up time	TenPLL	-	-	150	us	
Modulation Frequency	SSCMF	23	-	93	KHz	
Modulation Rate	SSCMR	-3	-	+3	%	LVDS clock = 81MHz, center spread

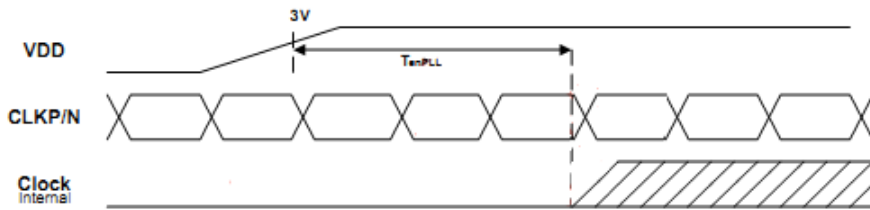

Figure 5.2.1 Relationship between VDD, LVDS clock, and internal clock

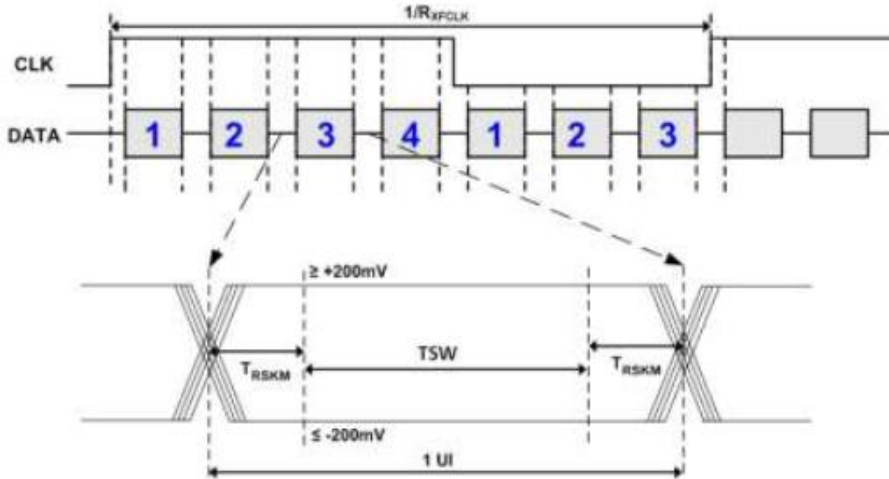

Figure 5.2.2 LVDS Data Skew

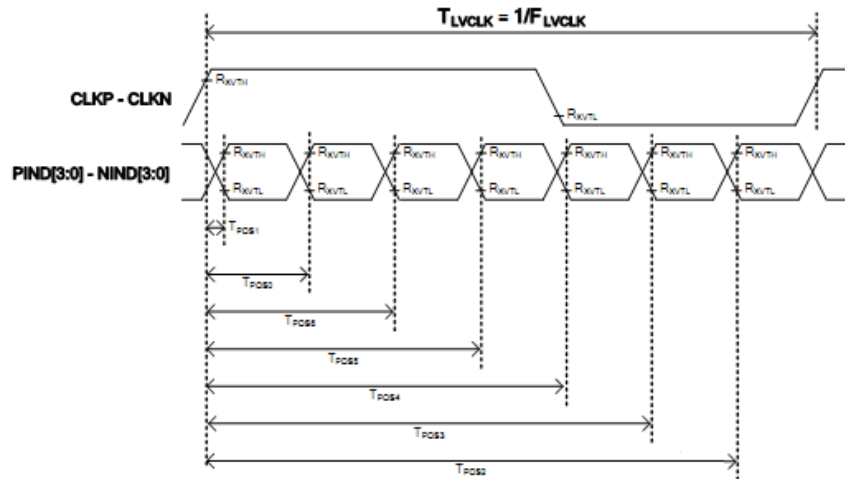
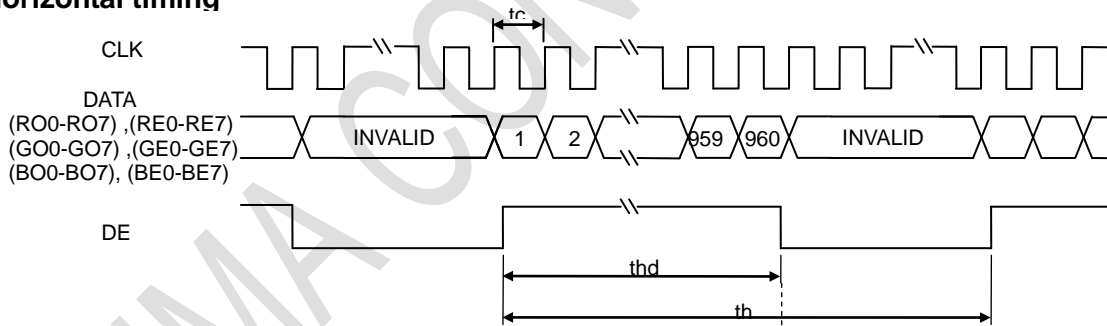

Figure 5.2.3 LVDS input timing

5.3 Timing input format

Horizontal timing



Vertical timing

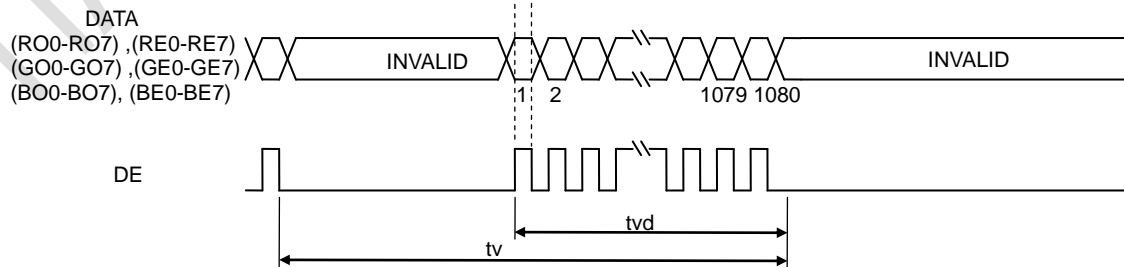

5.1.3 Timing characteristics

(Note1, Note2, Note3)

Parameter		Symbol	min.	typ.	max.	Unit	Remarks	
CLK	Frequency	1/tc	66.6	66.8	75.1	MHz	14.97 ns (typ.)	
DE	Horizontal	Cycle	th	1020	1024	1150	CLK	-
		Display period	thd	960			CLK	
	Vertical (One frame)	Cycle	tv	1086	1088	1209	H	-
		Display period	tvd	1080			H	

Note1: Definition of parameters is as follows.

tc= 1CLK, th= 1H

Note2: See the data sheet of LVDS transmitter.

Note3: Vertical cycle (tv) should be specified in integral multiple of Horizontal cycle (th).

5.4 Data input format

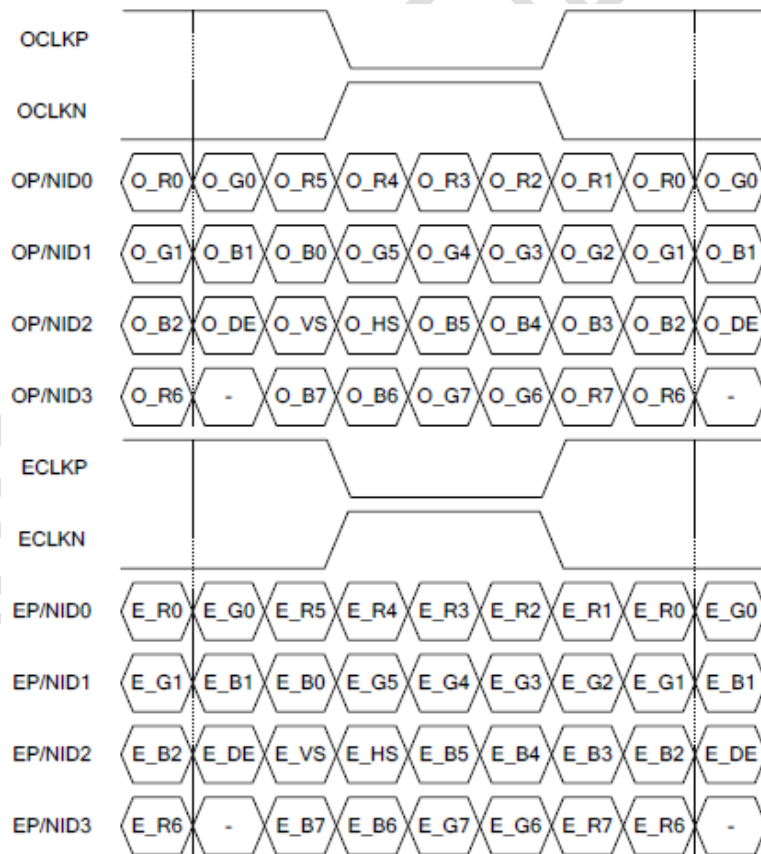

8-bit LVDS Dual Link VESA

6. Optical Characteristics

6.1 TFT Optical Characteristics

Item	Symbol	Condition	Min	Typ	Max	Unit	Remark
View Angles	θT	CR ≥ 10	70	88	--	Degree	Note 2
	θB		70	88	--		
	θL		70	88	--		
	θR		70	88	--		
Contrast Ratio	CR	θ=0°	800	900	--		Left/right 0° Top/bottom 5°
Response Time	T _r	25°C	--	25	35	ms	Note1 Note4
	T _f						
Chromaticity	White	x	Backlight is on	0.254	0.304	0.354	Note5 Note1
		y		0.273	0.323	0.373	
	Red	x		0.581	0.631	0.681	
		y		0.286	0.336	0.386	
	Green	x		0.262	0.312	0.362	
		y		0.562	0.612	0.662	
	Blue	x		0.099	0.149	0.199	
		y		0.003	0.053	0.103	
Uniformity	U		70	80	--	%	Note1、Note6
NTSC			65	70	--	%	
Luminance	L		1400	1600	--	cd/m ²	Note7
Flicker					-30	dB	Note8
Crosstalk					1.2	%	

Test Conditions:

- I_F= 40mA(one channel), the ambient temperature is 25°C.
- The test systems refer to Note 1 and Note 2.
- Flicker pattern: 128 Grayscale

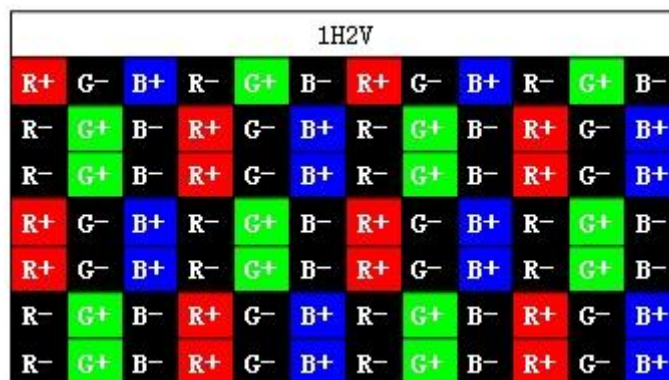

Note 1: Definition of optical measurement system.

The optical characteristics should be measured in dark room. After 10 Minutes operation, the optical properties are measured at the center point of the LCD screen. All input terminals LCD panel must be ground when measuring the center area of the panel.

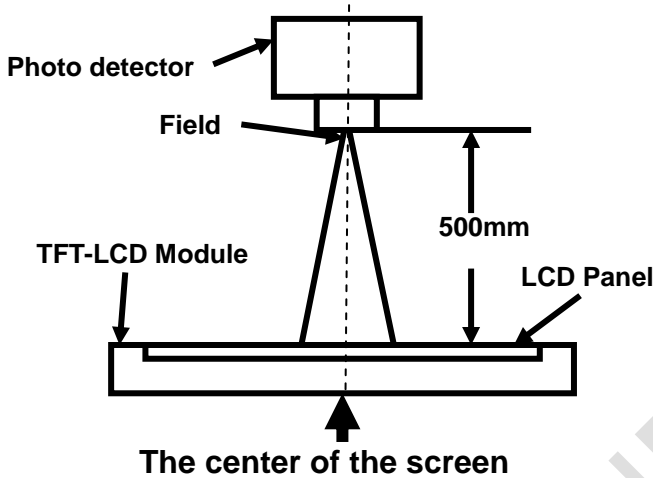

Note 2: Definition of viewing angle range and measurement system.

viewing angle is measured at the center point of the LCD.

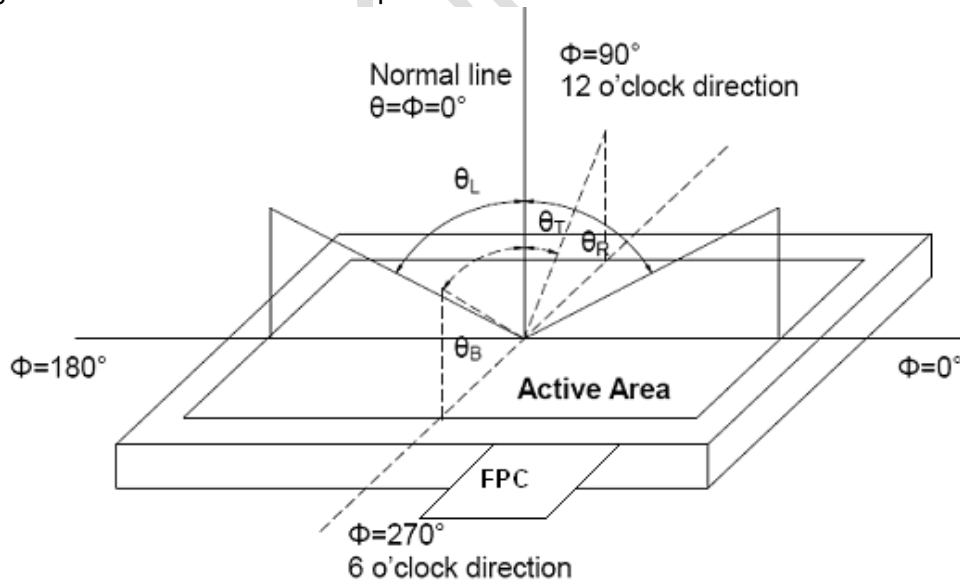

Note 3: Definition of contrast ratio

$$\text{Contrast ratio (CR)} = \frac{\text{Luminance measured when LCD is on the "White" state}}{\text{Luminance measured when LCD is on the "Black" state}}$$

“White state “: The state is that the LCD should drive by V_{white} .

“Black state”: The state is that the LCD should drive by V_{black} .

V_{white} : To be determined V_{black} : To be determined.

Note 4: Definition of Response time

The response time is defined as the LCD optical switching time interval between “White” state and “Black” state. Rise time (T_{ON}) is the time between photo detector output intensity changed from 90% to 10%. And fall time (T_{OFF}) is the time between photo detector output intensity changed from 10% to 90%.

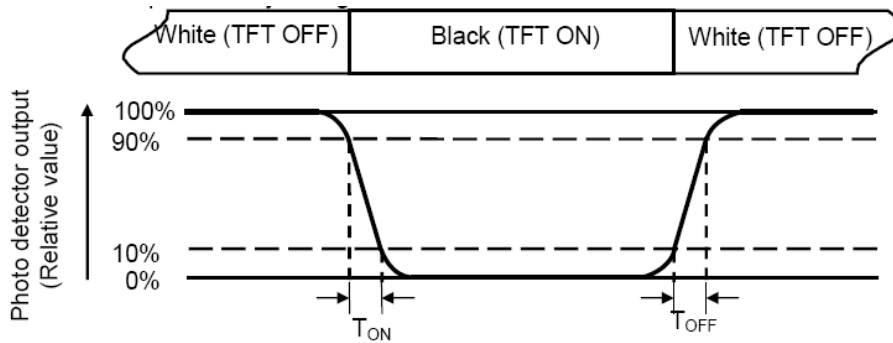

Note 5: Definition of color chromaticity (CIE1931)
 Color coordinates measured at center point of LCD.

Note 6: Definition of Luminance Uniformity

Active area is divided into 9 measuring areas (Refer Fig. 2). Every measuring point is placed at the center of each measuring area.

$$\text{Luminance Uniformity (U)} = L_{\min} / L_{\max}$$

L-----Active area length W----- Active area width

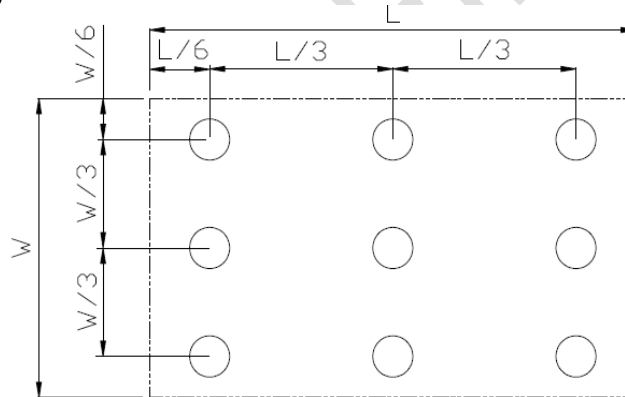

L_{\max} : The measured Maximum luminance of all measurement position.

L_{\min} : The measured Minimum luminance of all measurement position.

Note 7: Definition of Luminance:

Measure the luminance of white state at center point.

Note 8: Flicker should be measured by CA 310.

7 Environmental / Reliability Test

No	Test Item	Condition	Remarks
1	High Temperature Operation	Ta = +80°C, 240 hours	Note1,Note6,Note7 IEC60068-2-1,GB2423.2
2	Low Temperature Operation	Ta = -20°C, 240 hours	Note1, Note7,IEC60068-2-1 GB2423.1
3	High Temperature Storage	Ta = +85°C, 240 hours	Note1, Note7,Note8 IEC60068-2-1 GB2423.2
4	Low Temperature Storage	Ta = -30°C, 240 hours	Note1, Note7,EC60068-2-1 GB2423.1
5	High Temperature & Humidity Storage	Ta=+60°C · RH=90%, 240 hours	Note1,Note3, Note4,Note7 IEC60068-2-78 GB/T2423.3
6	Thermal Shock/ Solder Joint Life Test	-30°C (30min) -80°C (30min) ,Change Time:5min,100cycle	Note1,Note9 Start with cold temperature End with high temperature, IEC60068-2-14,GB2423.22
7	ESD	C=150pF · R=330Ω Air: ±8KV Contact:±4KV 5times (Environment:15°C~35°C, 30%~60%.86Kpa~106Kpa)	Note2,Note5, IEC61000-4-2 GB/T17626.2
8	Shock Test	Half Sine Wave 60G ,6ms,±X,±Y,±Z 3times for each direction	Note2
9	Drop Test(package state)	Height:60cm, 1corner,3edges,6surfaces	Note2,IEC60068-2-32 GB/T2423.8
10	Image sticking test	60°C 4 hours judge without release	No Image sticking

Note1: Ta is the ambient temperature of sample.

Note2: Before cosmetic and function test, the product must have enough recovery time, at least 2 hours at room temperature.

Note3: In the standard condition, there shall be no practical problem that may affect the display function. After the reliability test, the product only guarantees operation, but don't guarantee all of the cosmetic specification.

Note4: Operate with chess board pattern as blew and lasting time and temperature is 60°C 4 hours. Then judge with 50% gray level, the Image sticking should disappear immediately.

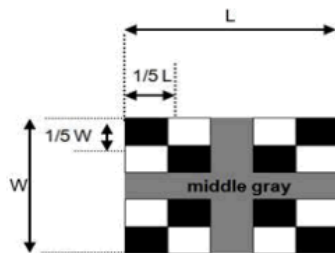

8 Mechanical Drawing

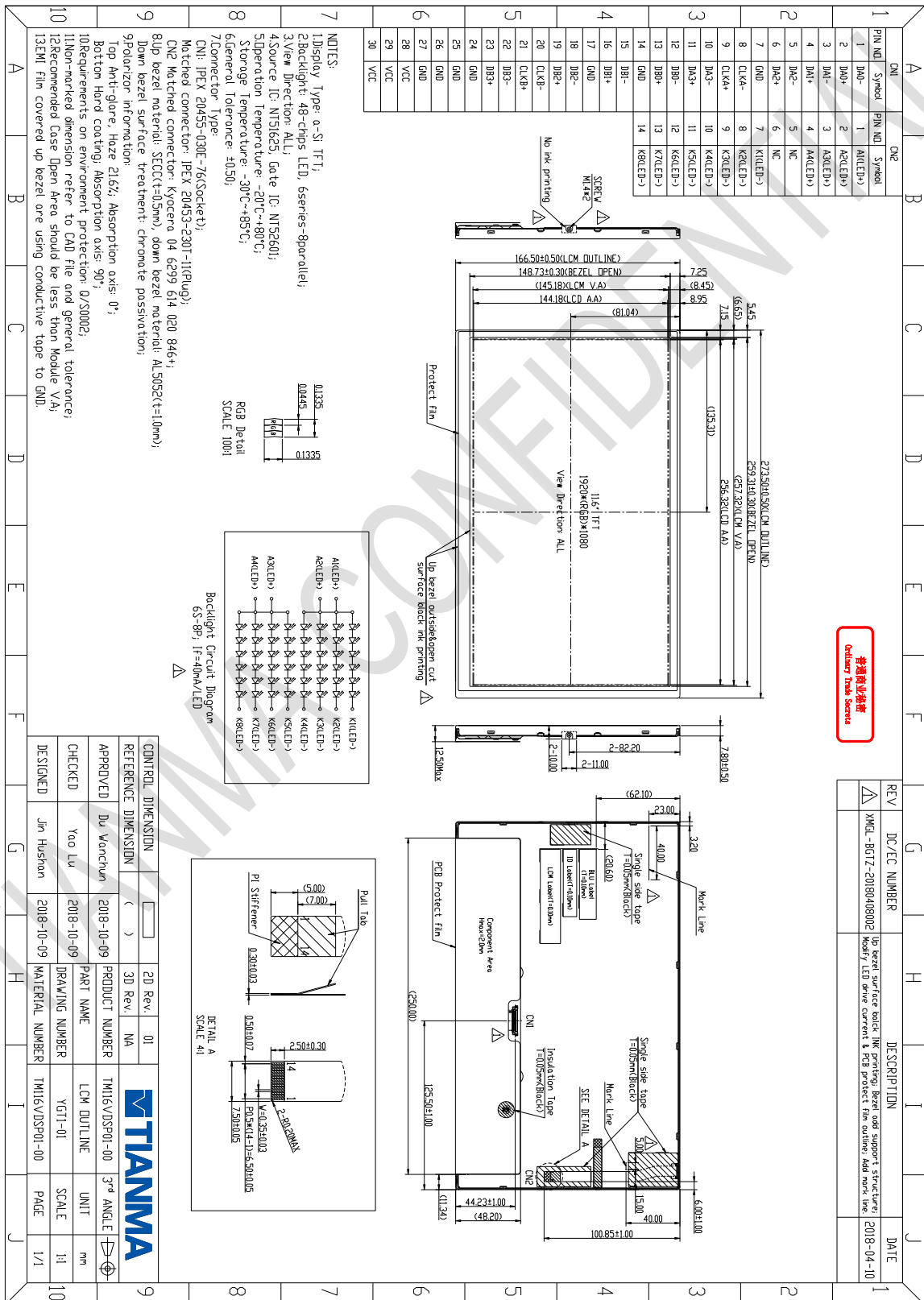

The information contained herein is the exclusive property of TIANMA MICRO-ELECTRONICS Corporation, and shall not be distributed, reproduced, or disclosed in whole or in part without prior written permission of TIANMA MICRO-ELECTRONICS Corporation.

9.Packaging Material

No	Item	Model (Material)	Dimensions(mm)	Unit Weight(Kg)	Quantity																						
1	LCM module	TM116VDSP01-00	273.50*166.50*7.80	0.527	14																						
2	Partition_1	Corrugated Paper	513.00x413.00x240	1.42	1																						
3.	Anti-Static Bubble Bag	PE	270x295	0.01	14																						
4	Dust-Proof Bag	PE	700*545	0.06	1																						
5	Partition_2	Corrugated Paper	513x413	0.1	1																						
6	Corrugated Bar	Corrugated Paper	367x305x48	7	Crepe Paper Tape	Tape	30*10	0.00003	42	8	Carton	Corrugated Paper	530x430x274	0.76	1	9	LABEL	Label	100x52	0.000345	1	10	Total weight		10±5%Kg		
7	Crepe Paper Tape	Tape	30*10	0.00003	42																						
8	Carton	Corrugated Paper	530x430x274	0.76	1																						
9	LABEL	Label	100x52	0.000345	1																						
10	Total weight		10±5%Kg																								

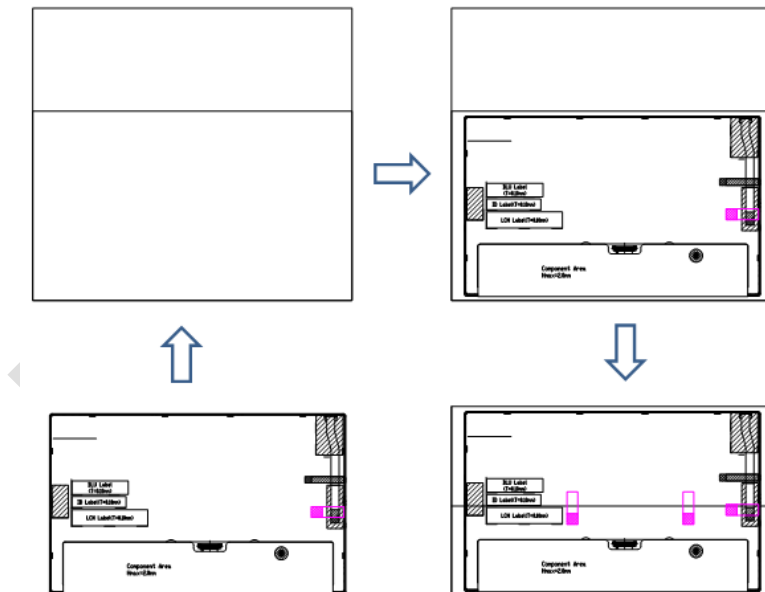



FINAL

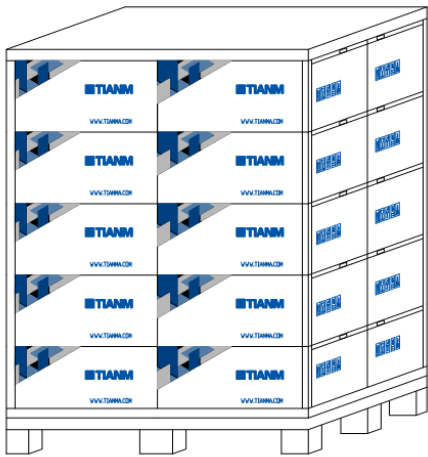
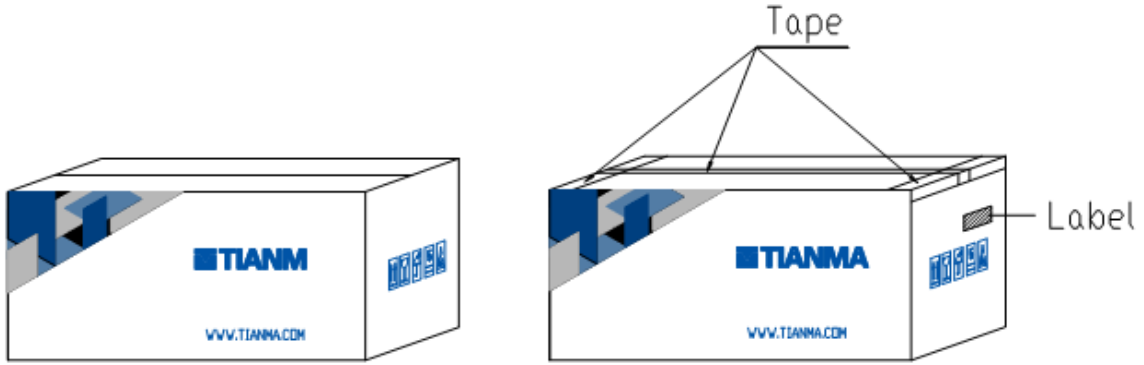

10. Precautions for Use of LCD Modules

10.1 Handling Precautions

- 10.1.1 The display panel is made of glass. Do not subject it to a mechanical shock by dropping it from a high place, etc.
- 10.1.2 If the display panel is damaged and the liquid crystal substance inside it leaks out, be sure not to get any in your mouth, if the substance comes into contact with your skin or clothes, promptly wash it off using soap and water.
- 10.1.3 Do not apply excessive force to the display surface or the adjoining areas since this may cause the color tone to vary.
- 10.1.4 The polarizer covering the display surface of the LCD module is soft and easily scratched. Handle this polarizer carefully.
- 10.1.5 If the display surface is contaminated, breathe on the surface and gently wipe it with a soft dry cloth. If still not completely clear, moisten cloth with one of the following solvents:
- Isopropyl alcohol
 - Ethyl alcohol
- Solvents other than those mentioned above may damage the polarizer.
Especially, do not use the following:
- Water
 - Ketone
 - Aromatic solvents
- 10.1.6 Do not attempt to disassemble the LCD Module.
- 10.1.7 If the logic circuit power is off, do not apply the input signals.
- 10.1.8 To prevent destruction of the elements by static electricity, be careful to maintain an optimum work environment.
- a. Be sure to ground the body when handling the LCD Modules.
 - b. Tools required for assembly, such as soldering irons, must be properly ground.
 - c. To reduce the amount of static electricity generated, do not conduct assembly and other work under dry conditions.
 - d. The LCD Module is coated with a film to protect the display surface. Be care when peeling off this protective film since static electricity may be generated.

10.2 Storage precautions

10.2.1 When storing the LCD modules, avoid exposure to direct sunlight or to the light of fluorescent lamps.

10.2.2 The LCD modules should be stored under the storage temperature range. If the LCD modules will be stored for a long time, the recommend condition is:

Temperature : 0°C ~ 40°C

Relatively humidity: ≤80%

10.2.3 The LCD modules should be stored in the room without acid, alkali and harmful gas.

10.3 The LCD modules should be no falling and violent shocking during transportation, and also should avoid excessive press, water, damp and sunshine.

10.4 Bar Code definition on module



Take TM062RDS01 as an example.

Lot No:

01 1 A 1 14 9 23 001

① ② ③ ④ ⑤ ⑥ ⑦ ⑧

- ① Management code
- ② Grade code
- ③ Version
- ④ Product line
- ⑤ Check year (14 meaning is 2014)
- ⑥ Check month (1~9、A meaning is October, B meaning is November, C meaning is December)
- ⑦ Check date (01~31)
- ⑧ Lot Serial No

OEM No:

S 062RD1 A 66 SA 1 SA 1 497 0007

① ② ③ ④ ⑤ ⑥ ⑦ ⑧ ⑨ ⑩

- ① AVIC code
- ② Product No.
- ③ Version
- ④ Source IC&Gate IC vender code
- ⑤ Cell location code
- ⑥ Cell line code

The information contained herein is the exclusive property of TIANMA MICRO-ELECTRONICS Corporation, and shall not be distributed, reproduced, or disclosed in whole or in part without prior written permission of TIANMA MICRO-ELECTRONICS Corporation.

- ⑦ Module location code
- ⑧ Module line code
- ⑨ YEAR: 0~9(1 meaning is 2011, 2 meaning is 2012), month: 1~9, A~C, date: 1~9, A~V.
- ⑩ Serial No.

TIANMA CONFIDENTIAL