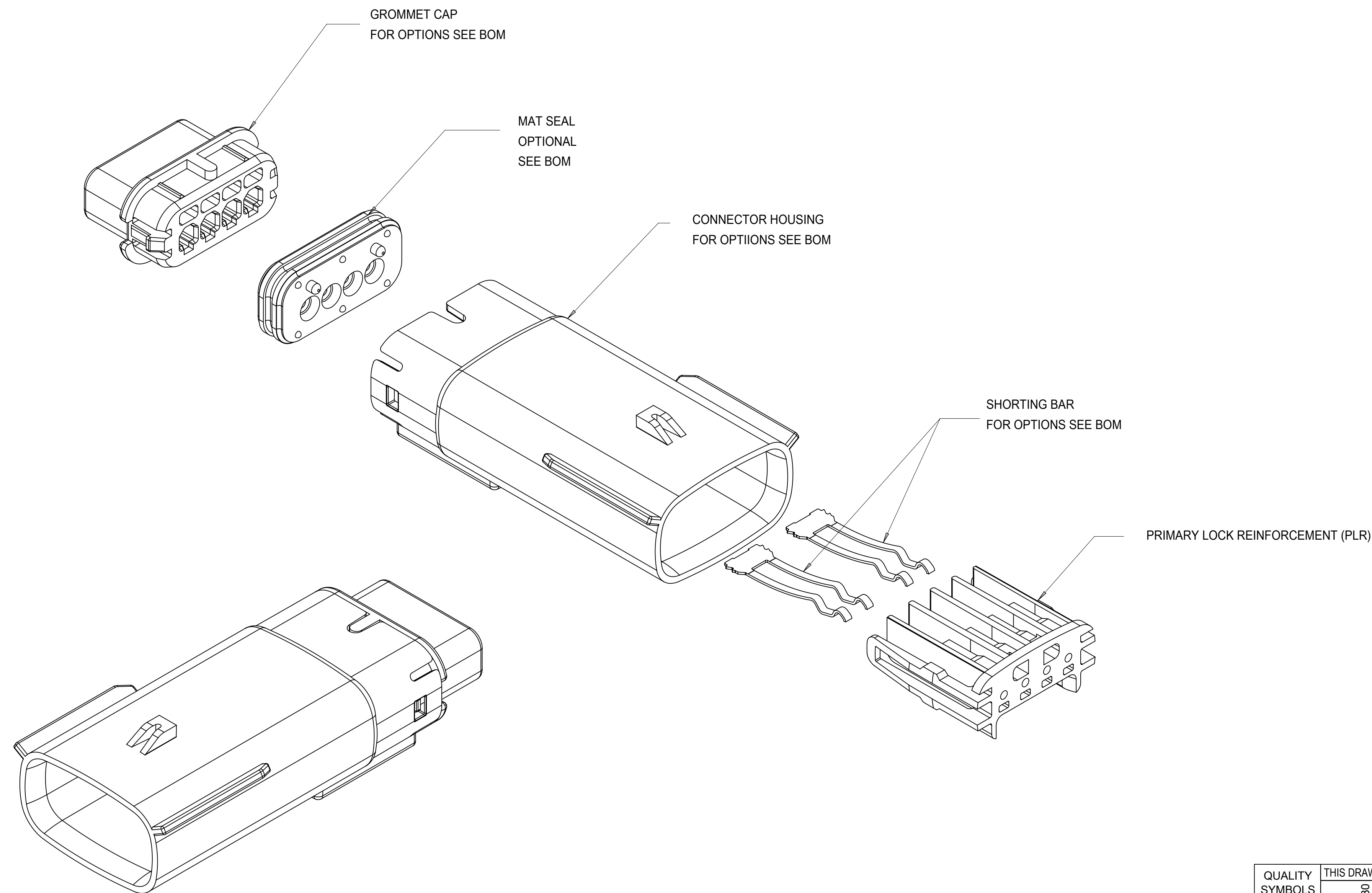

TABLE OF CONTENTS	
SHEET NO.	SHEET DESCRIPTION
1	NOTES
2	KEY CONFIGURATIONS
3	BLADE SEALED ASSEMBLY
4	SYSTEM PACKAGING
5	BOM



NOTES: VALID UNLESS OTHERWISE SPECIFIED

1. GENERAL:
  - a. APPLICATION SPECIFICATION SEE: AS-33472-100  
CONTAINS: PRODUCT INTRODUCTION, PRODUCT SUMMARY, CONNECTOR ASSEMBLY, PACKAGING INFORMATION, CONNECTOR MATING, SERVICE INSTRUCTIONS, ELECTRICAL CONTINUITY CHECKING, CRIMPING, AND TROUBLESHOOTING.  
-DESIGNED TO MATE WITH RECEPTACLE SEALED ASSEMBLY SPECIFIED IN MOLEX DRAWING SD-33471-041. RECEPTACLE SEALED ASSEMBLY CONFIGURATION MUST CONTAIN A PLR WITH SHORTING BAR LIFTER.  
-FOR 1.5mm BLADE TERMINALS TO BE USED WITH THE SHORTING BAR CIRCUIT LOCATIONS SEE MOLEX DRAWING SD-31296-001.  
-SHORTING BAR TERMINALS TO BE USED WITH WIRE WITHIN DIAMETER RANGE OF 1.7mm TO 2.06mm.  
-FOR 1.5mm BLADE TERMINALS TO BE USED WITH THE NON-SHORTING BAR CIRCUIT LOCATIONS SEE MOLEX DRAWING SD-33000-001.  
-NON-SHORTING BAR TERMINALS TO BE USED WITH WIRE WITHIN DIAMETER RANGE OF 1.2mm TO 2.69mm.  
-ASSEMBLY SHIPPED WITH PLR IN PRE-LOCK POSITION  
-IN THE EVENT THAT THE PLR IS FOUND IN THE SEATED (FINAL LOCK) POSITION, REFER TO MOLEX SPECIFICATION PS-34646-001, AVAILABLE AT [www.molex.com](http://www.molex.com) <http://www.molex.com>  
-ASSEMBLY CONFORMS TO SAE/USCAR-2 REV.4 WITH THE FOLLOWING EXCEPTIONS: TERMINAL INSERTION FORCE FOR WIRE DIAMETER ABOVE 2.5mm NOT EXCEEDING 2.69mm SHALL NOT EXCEED 45 NEWTONS.
  - b. PRODUCT SPECIFICATION SEE: PS-33471-000  
CONTAINS: PRODUCT INTRODUCTION, PRODUCT SUMMARY, RATINGS (CURRENT, TEMPERATURE, SEALING, AND FLAMMABILITY), AND PRODUCT VALIDATION.
  - c. PACKAGING SPECIFICATION PER MOLEX DRAWING: PK-31300-635
  - d. PARTS MUST BE IN COMPLIANCE TO MOLEX CHEMICAL SUBSTANCES FOR PRODUCTS AND PACKAGING SPECIFICATION: ES-40000-5016
  - e. DATA MUST BE SUBMITTED UNDER THE MOLEX PART NUMBER TO IMDS (COMPANY ID#13255)
  - f. FOR INFORMATION ON 1X4 BLADE SEALED ASSEMBLY WITHOUT SHORTING BAR SEE SD-33481-041.
2. DESIGN - MATERIALS:
  - a. CONNECTOR HOUSING, GROMMET CAP, PLR: SPS/NYLON BLEND 20% GLASS FILLED
  - b. MAT SEAL: INHERENTLY LUBRICATED SILICONE
  - c. SHORTING BARS: STAINLESS STEEL
3. DESIGN - GEOMETRY:
  - a. THIS IS A 100% CAD GENERATED PART. THE CAD MATHEMATICAL DATA IS THE MASTER FOR THIS PART. FOR DIMENSIONAL OR ANY INFORMATION NOT SHOWN ON THIS DRAWING, ANALYZE THE CAD MODEL.
  - b. GEOMETRIC DIMENSIONS AND TOLERANCES PER ASME Y14.5M - 1994
  - c. EDGES AND UNDIMENSIONED DETAILS PER ISO13715
  - d. CORNERS SHOWN AS SHARP TO BE R 0.2 MAX.
  - e. LETTERING SHALL BE 0.15 MAX RAISED IN 0.25 MAX RECESS PAD. THIS INCLUDES RECYCLING CODE, CAVITY ID, VENDOR IDENTIFICATION, AND CUSTOMER MATERIAL NUMBER.
  - f. VISUAL DEFECTS SHALL MEET COSMETIC STANDARD PS-45499-002 (Class B)
  - g. LASER MARKING: TBD

K2	ADDED NEW P/N 31280-4436 TO 31280-4451
K	ADDED NEW P/N 31280-0450 31280-0451
J	ADDED NEW P/N 31280-0449
H	ADDED NEW P/N 31280-0448
G	UPDATED GROMMET CAP
F1	UPDATED DIMENSIONS TO MATCH MODEL
F	REDRAWN
REV	DESCRIPTION

QUALITY SYMBOLS		THIS DRAWING CONTAINS INFORMATION THAT IS PROPRIETARY TO MOLEX ELECTRONIC TECHNOLOGIES, LLC AND SHOULD NOT BE USED WITHOUT WRITTEN PERMISSION	
	= 0	EC NO: 167392 DRWN: LSONG05 CHKD: REV APPR: MVANSLAMBROU	GENERAL TOLERANCES (UNLESS SPECIFIED) DIMENSION UNITS: mm SCALE: 3:1 DRWN BY: KCUNNINGHAM DATE: 2012/08/28 CHKD BY: MDICK DATE: 2013/03/22 APPR BY: VKOSHY DATE: 2012/09/04 DRAWING SIZE: D THIRD ANGLE PROJECTION
	= 0		
	= 0		
	= 0		
	= 0		
	= 0		
	= 0	DRAFT WHERE APPLICABLE MUST REMAIN WITHIN DIMENSIONS	SERIES: 31280 MATERIAL NUMBER: SEE BOM CUSTOMER: GENERAL MARKET
RELEASE STATUS: P1 RELEASE DATE: 31.10.2017 21:13:47		DOCUMENT NUMBER: SD-31280-200 DOC TYPE: PSD DOC PART: 001 SHEET NUMBER: 1 OF 5	

**molex**

MX150 1X4 BLADE SEALED ASSEMBLY MAT SEAL, SHORTING BAR

PRODUCT CUSTOMER DRAWING

KEY CONFIGURATIONS

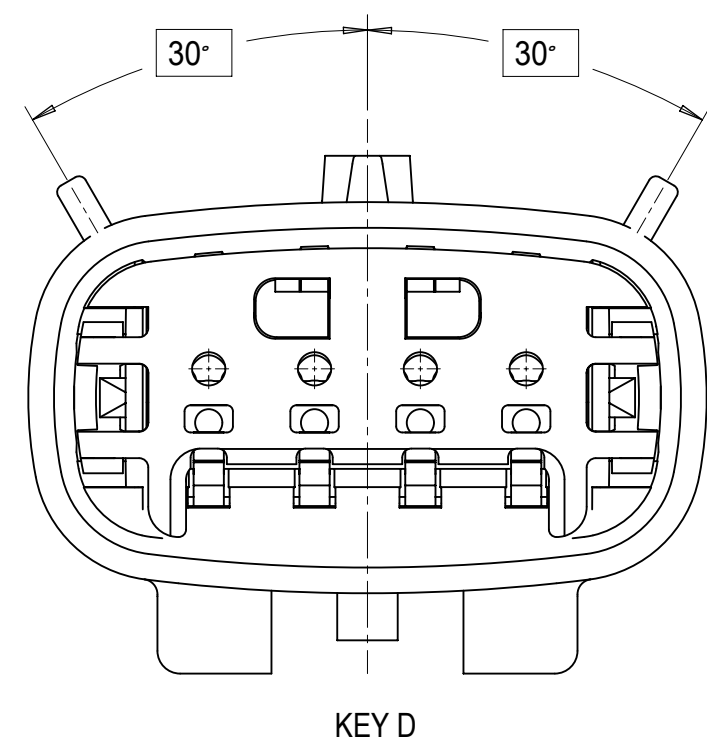
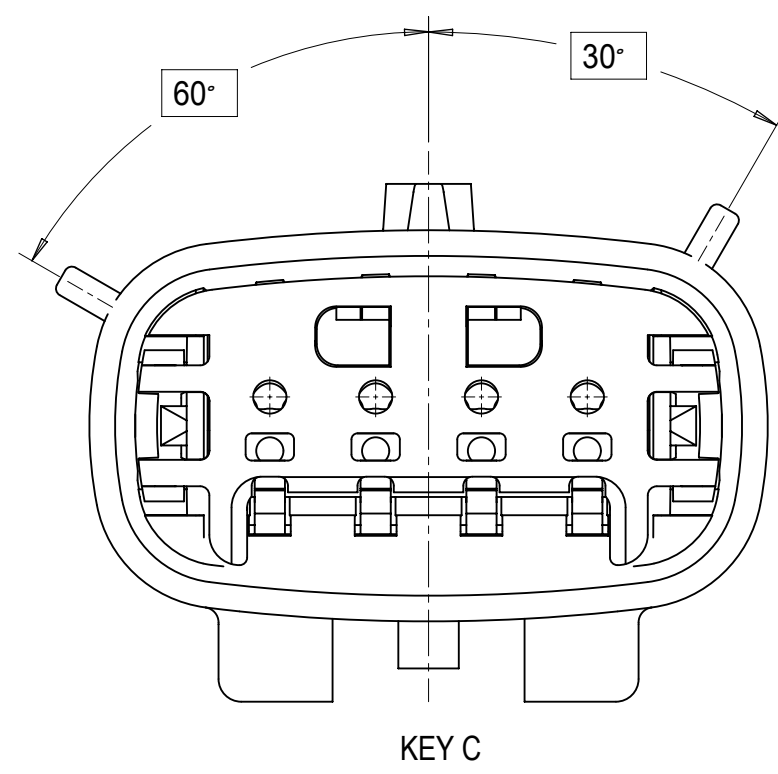
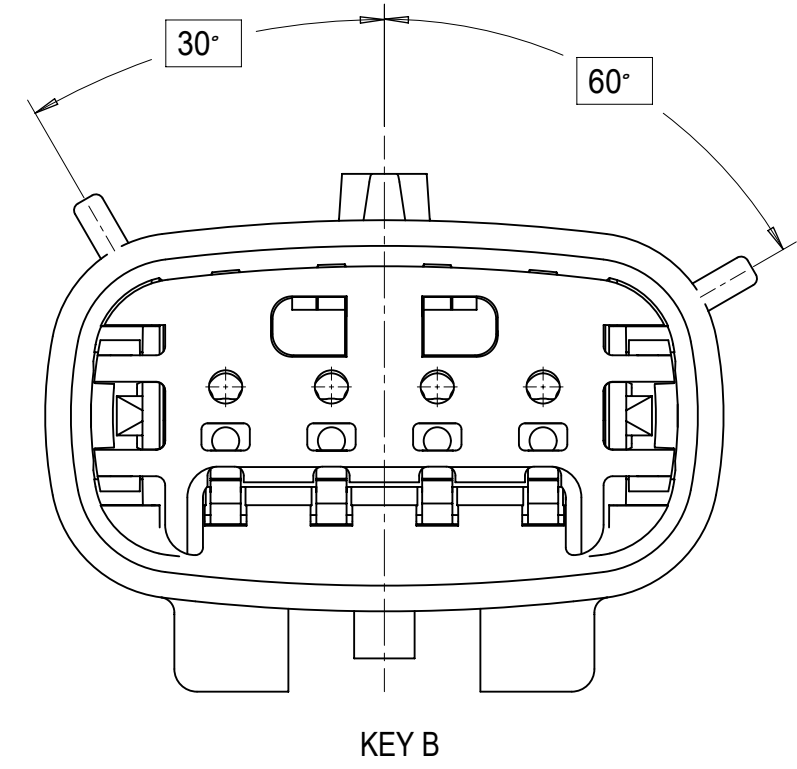
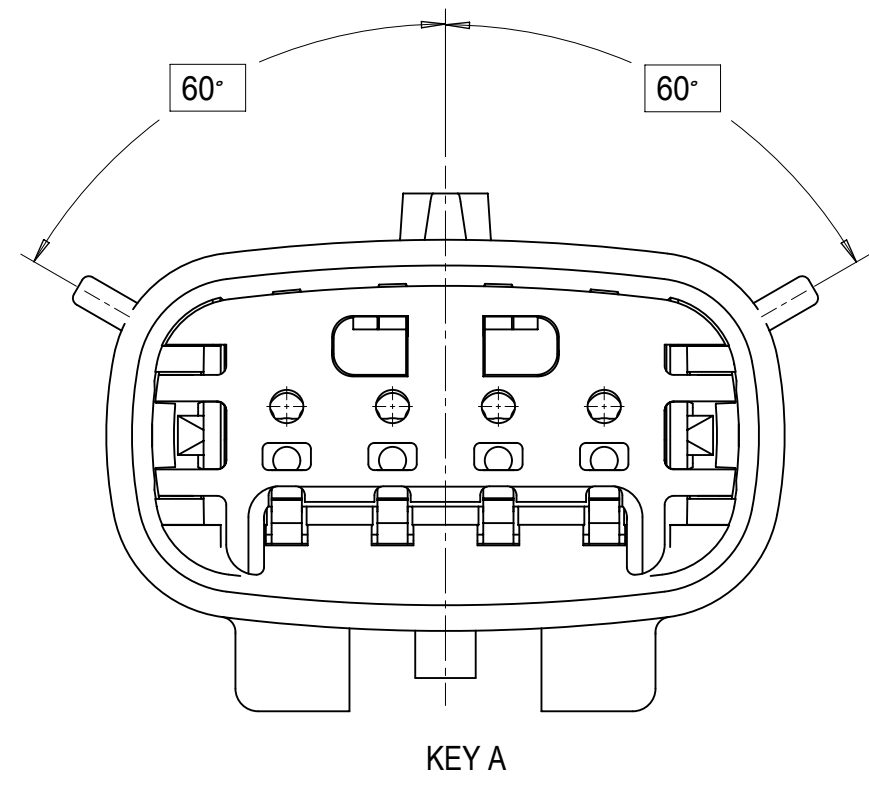

<b>QUALITY SYMBOLS</b> = 0 = 0 = 0 = 0 = 0 = 0 = 0 = 0 = 0	THIS DRAWING CONTAINS INFORMATION THAT IS PROPRIETARY TO MOLEX ELECTRONIC TECHNOLOGIES, LLC AND SHOULD NOT BE USED WITHOUT WRITTEN PERMISSION											
	2017/10/30	2017/10/31	GENERAL TOLERANCES (UNLESS SPECIFIED)		DIMENSION UNITS	SCALE						
			ANGULAR TOL ± 1.0 °		mm	4:1						
	EC NO: 167392 DRWN: LSONG05 CHK'D: REV APPR: MVANSLAMBROU	4 PLACES ±	DRWN BY		DATE	KCUNNINGHAM		2012/08/28		MX150 1X4 BLADE SEALED ASSEMBLY MAT SEAL, SHORTING BAR		
		3 PLACES ±	CHKD BY		DATE	MDICK		2013/03/22				
		2 PLACES ± 0.1	APPR BY		DATE	VKOSHY		2012/09/04				
		1 PLACE ± 0.3	DRAWING SIZE		THIRD ANGLE PROJECTION		D				PRODUCT CUSTOMER DRAWING	
		0 PLACES ±	DRAFT WHERE APPLICABLE MUST REMAIN WITHIN DIMENSIONS		SERIES		MATERIAL NUMBER		CUSTOMER		31280 SEE BOM GENERAL MARKET	
	K2		DOCUMENT NUMBER		DOC TYPE		DOC PART		SHEET NUMBER		SD-31280-200 PSD 001 2 OF 5	

OPTIONAL LASER MARKING THIS SURFACE  
SEE NOTE 3g.

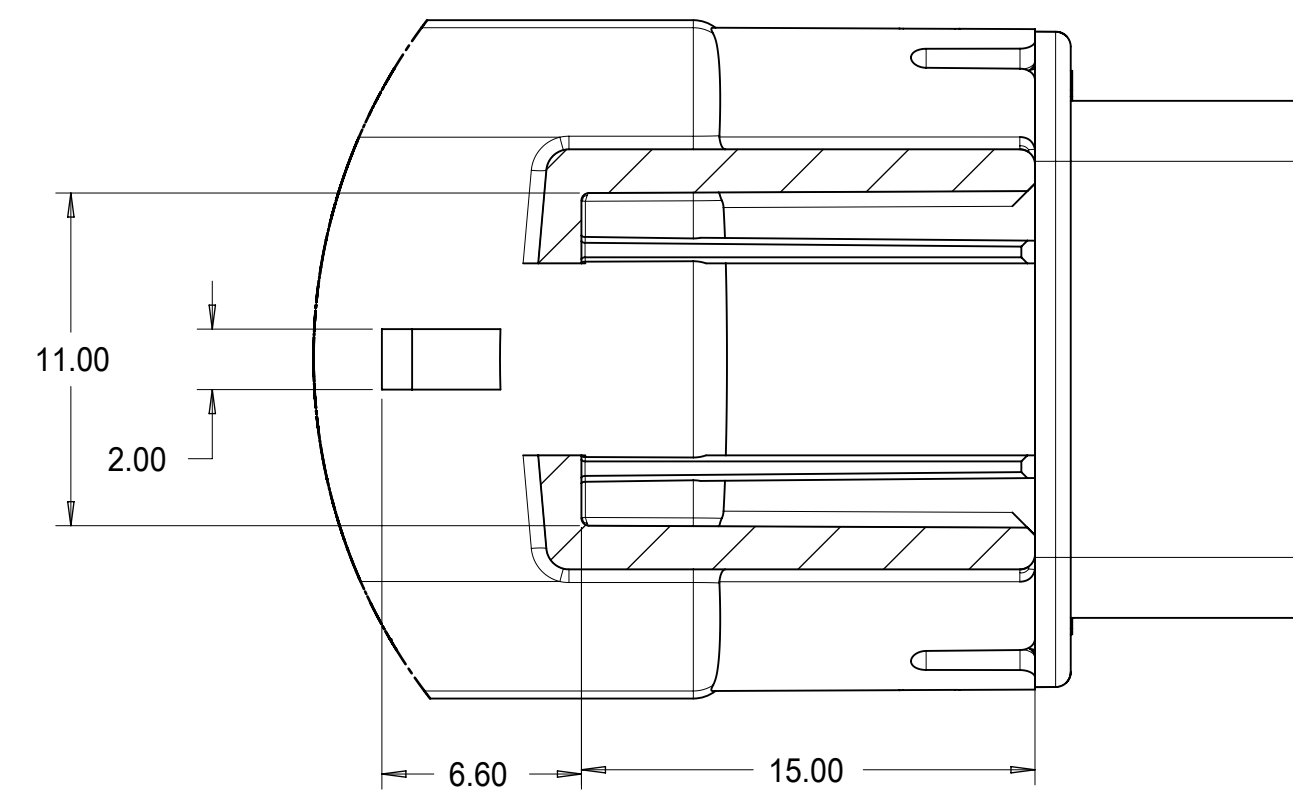
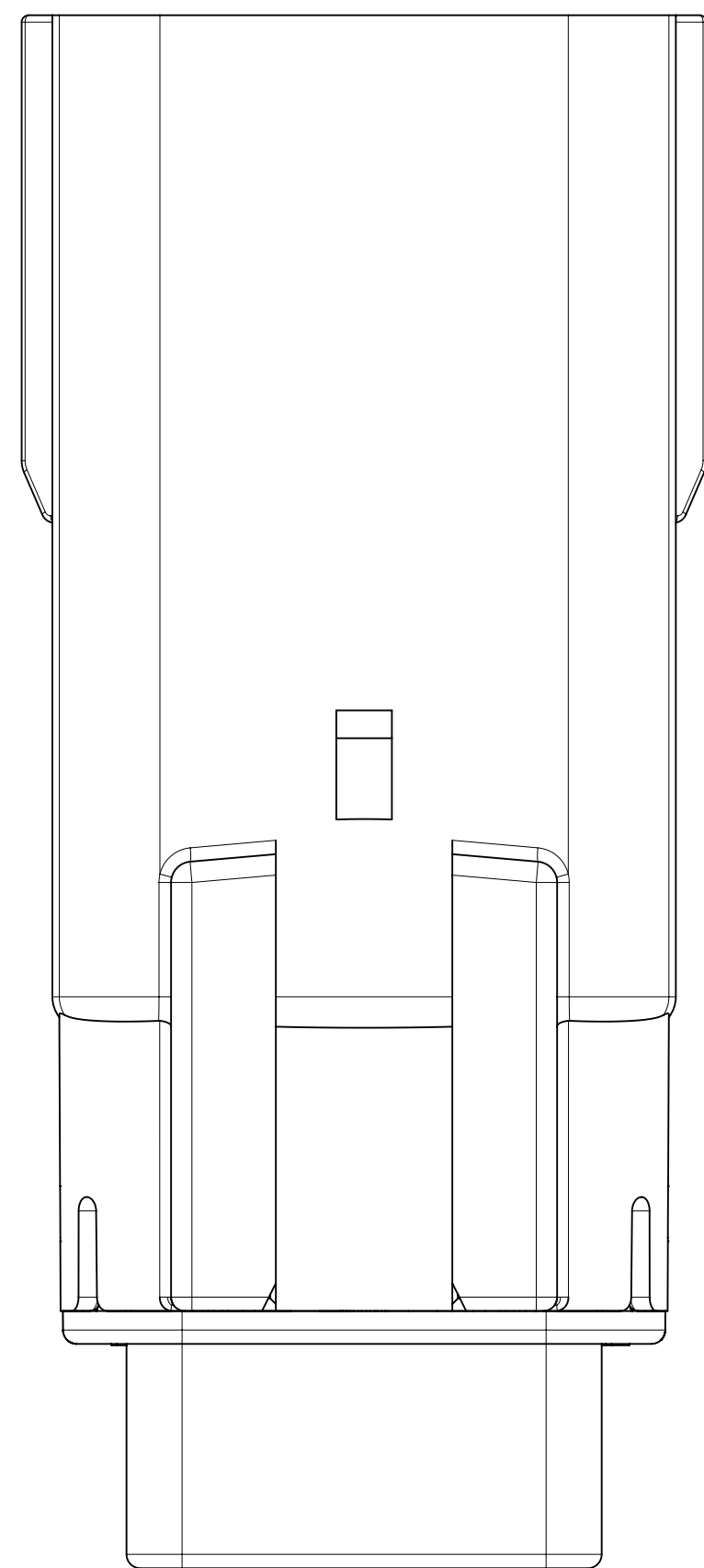
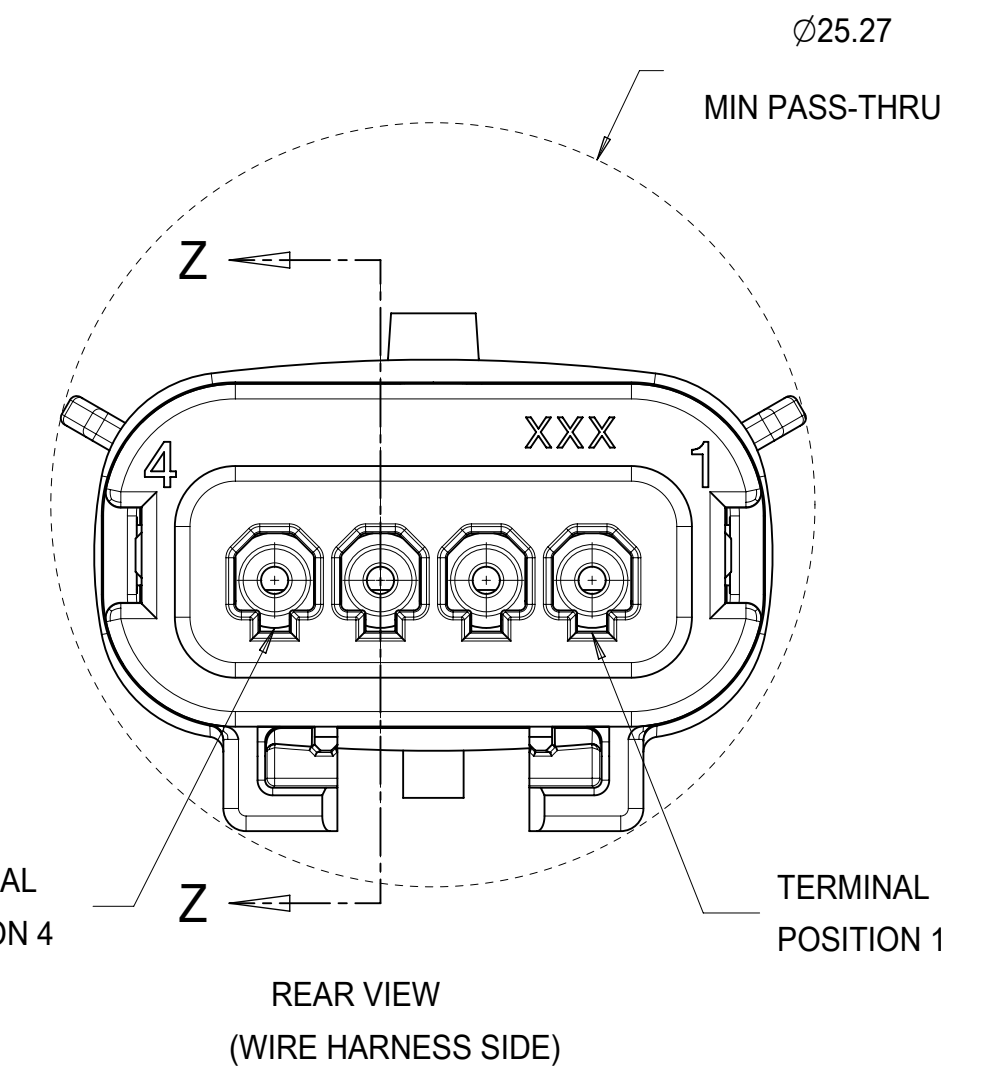
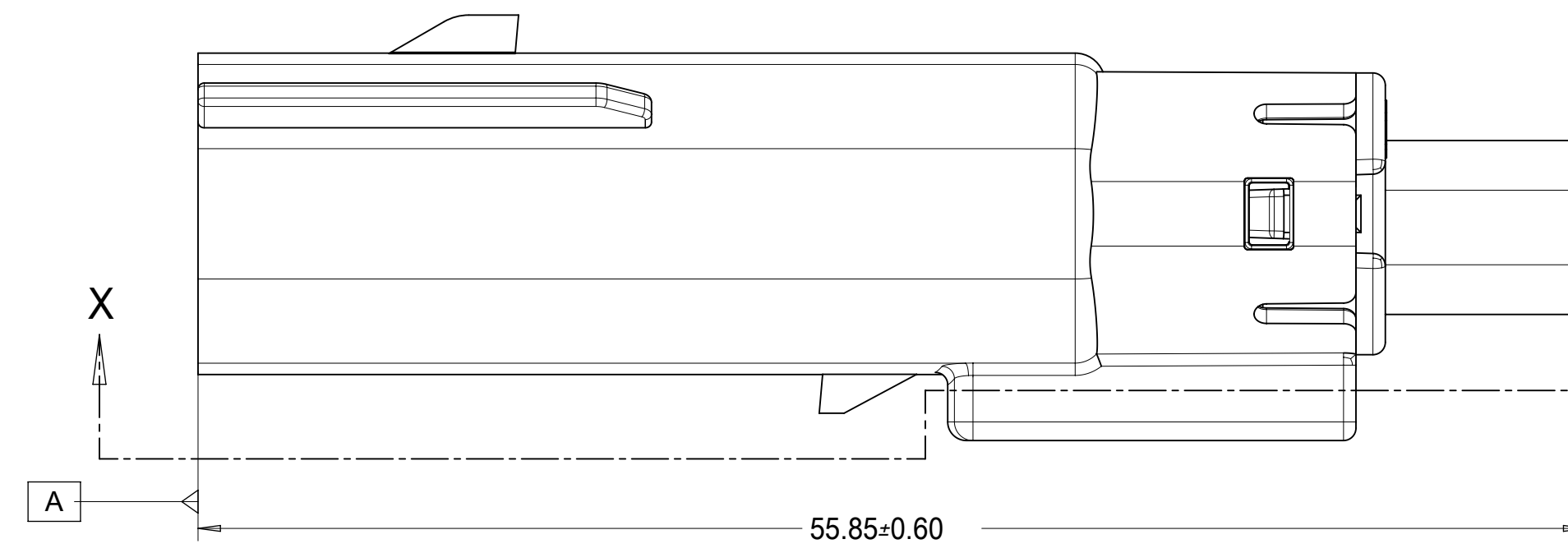
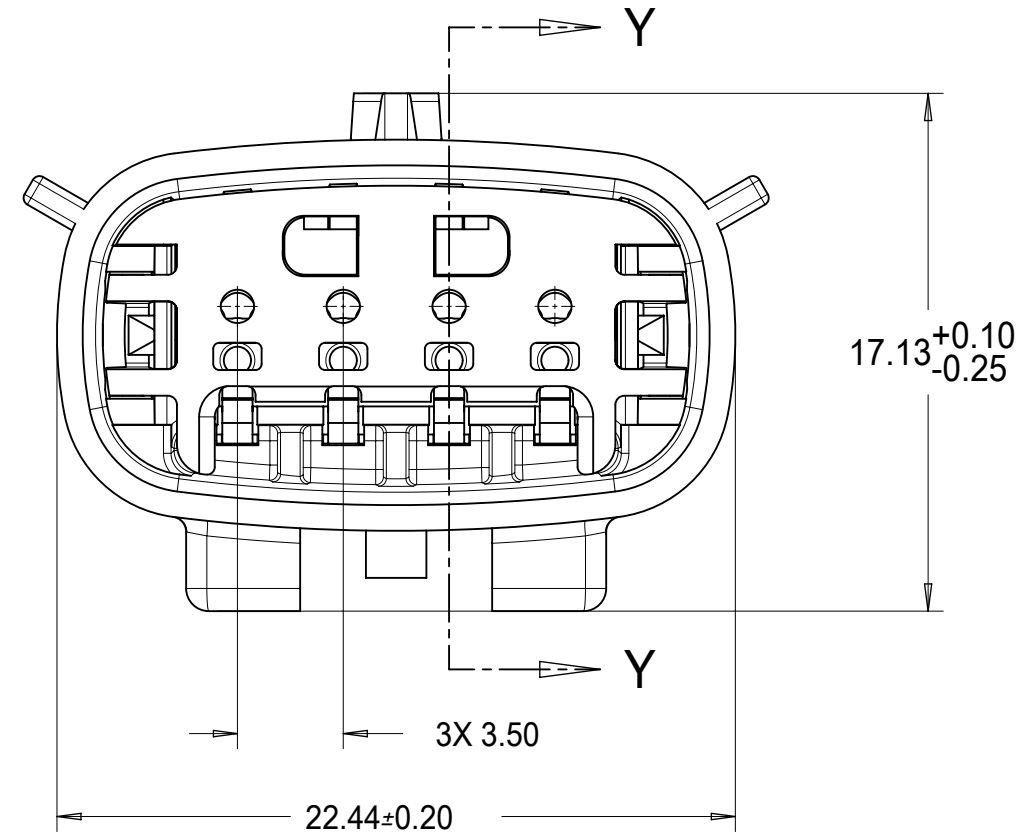
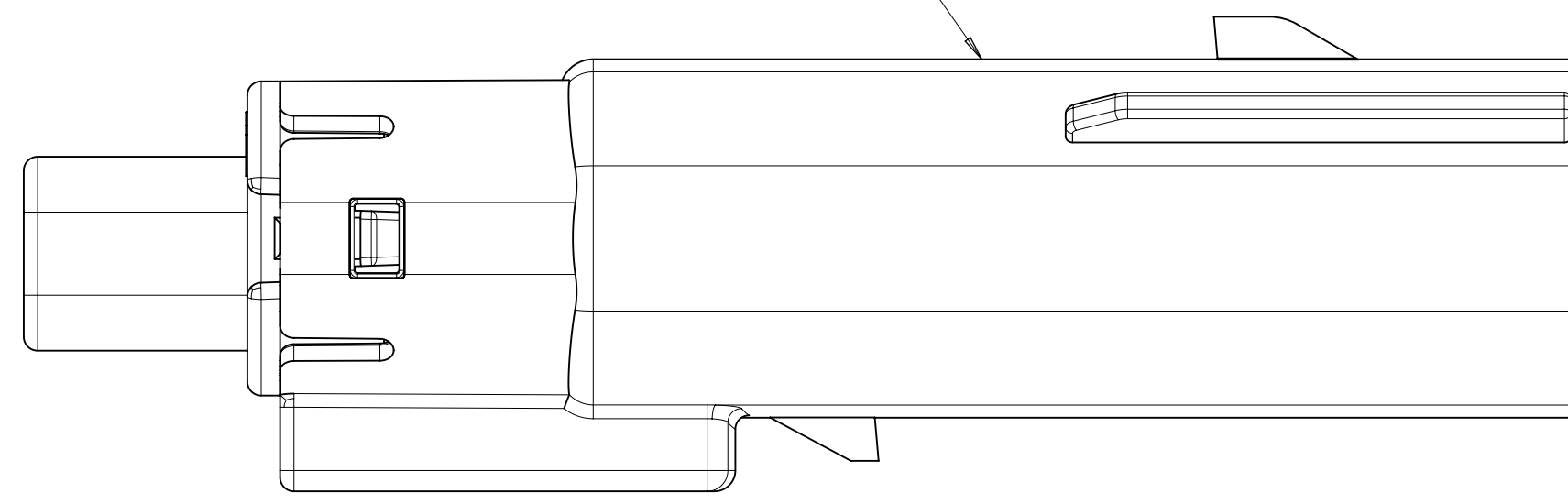

SECTION X-X  
SCALE 4:1

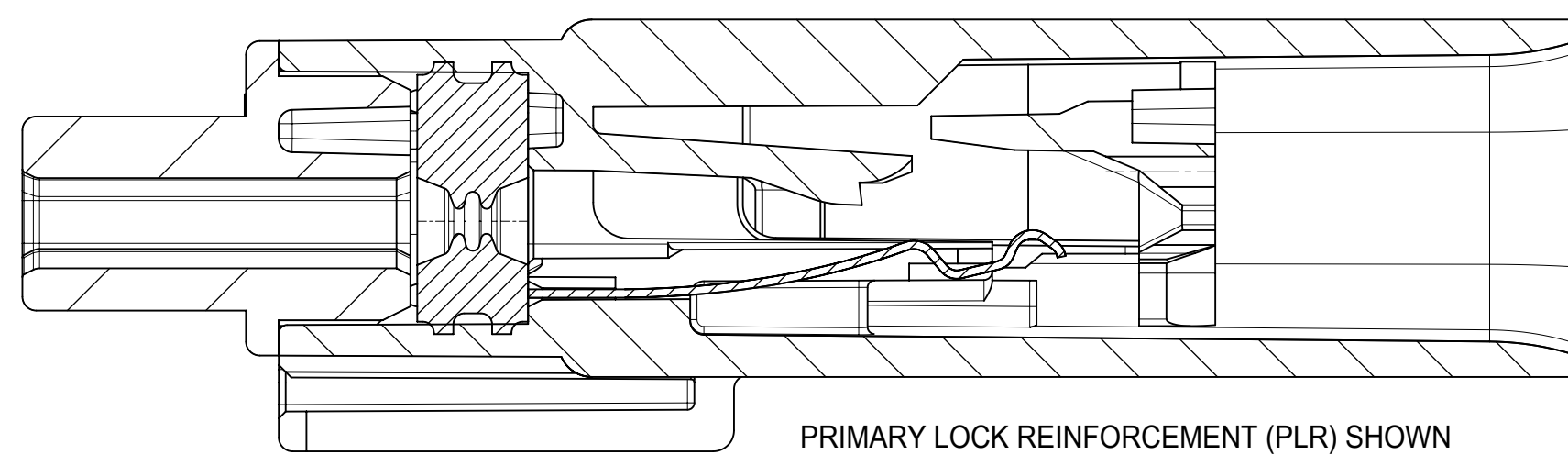

PRIMARY LOCK REINFORCEMENT (PLR) SHOWN  
IN PRE-STAGED POSITION

SECTION Z-Z

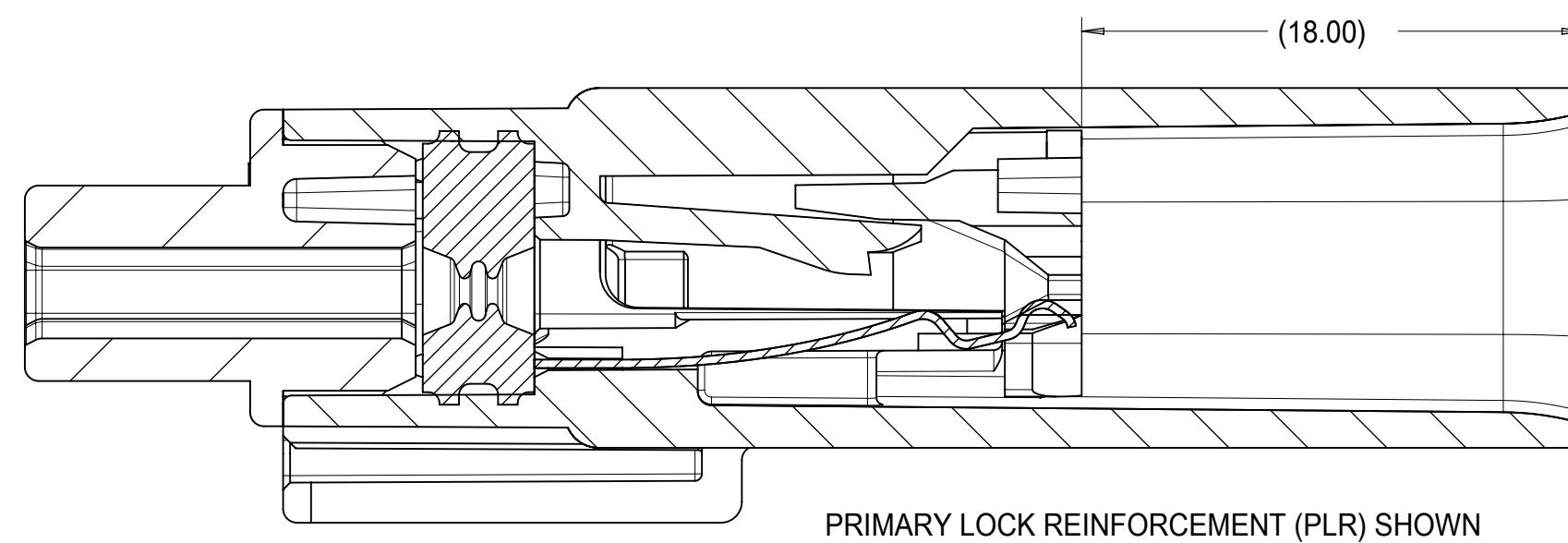

PRIMARY LOCK REINFORCEMENT (PLR) SHOWN  
IN FINAL-LOCK POSITION

SECTION Y-Y

THIS DRAWING CONTAINS INFORMATION THAT IS PROPRIETARY TO MOLEX ELECTRONIC TECHNOLOGIES, LLC AND SHOULD NOT BE USED WITHOUT WRITTEN PERMISSION										
QUALITY SYMBOLS	EC NO: 167392 DRWN: LSONG05 CHKD: MIVANSLAMBROU REV APPR:	2017/10/30 2017/10/31	GENERAL TOLERANCES (UNLESS SPECIFIED)		DIMENSION UNITS	SCALE				
			ANGULAR TOL ± 1.0 °		mm	4:1				
▽ = 0	DRAFT WHERE APPLICABLE MUST REMAIN WITHIN DIMENSIONS	K2	4 PLACES ±	KCUNNINGHAM	DATE	2012/08/28	MX150 1X4 BLADE SEALED ASSEMBLY MAT SEAL, SHORTING BAR			
▽ = 0			3 PLACES ±							CHKD BY
▽ = 0			2 PLACES ± 0.1	MDICK	DATE	2013/03/22	PRODUCT CUSTOMER DRAWING			
▽ = 0			1 PLACE ± 0.3							APPR BY
▽ = 0			0 PLACES ±	VKOSHY	DATE	2012/09/04	SERIES	MATERIAL NUMBER	CUSTOMER	
▽ = 0					DRAWING SIZE	THIRD ANGLE PROJECTION	31280	SEE BOM	GENERAL MARKET	
▽ = 0					DOCUMENT NUMBER	DOC TYPE	DOC PART	SHEET NUMBER		
					SD-31280-200	PSD	001	3 OF 5		

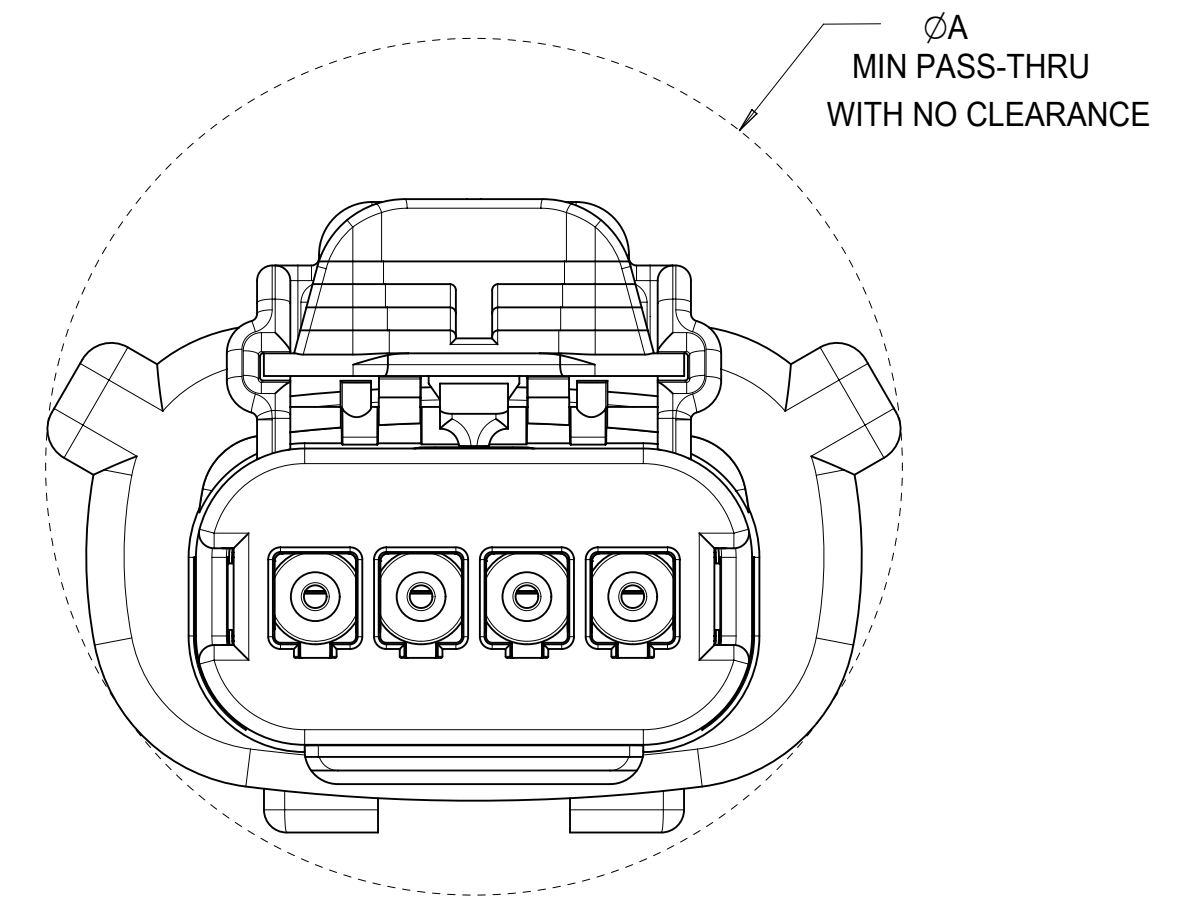
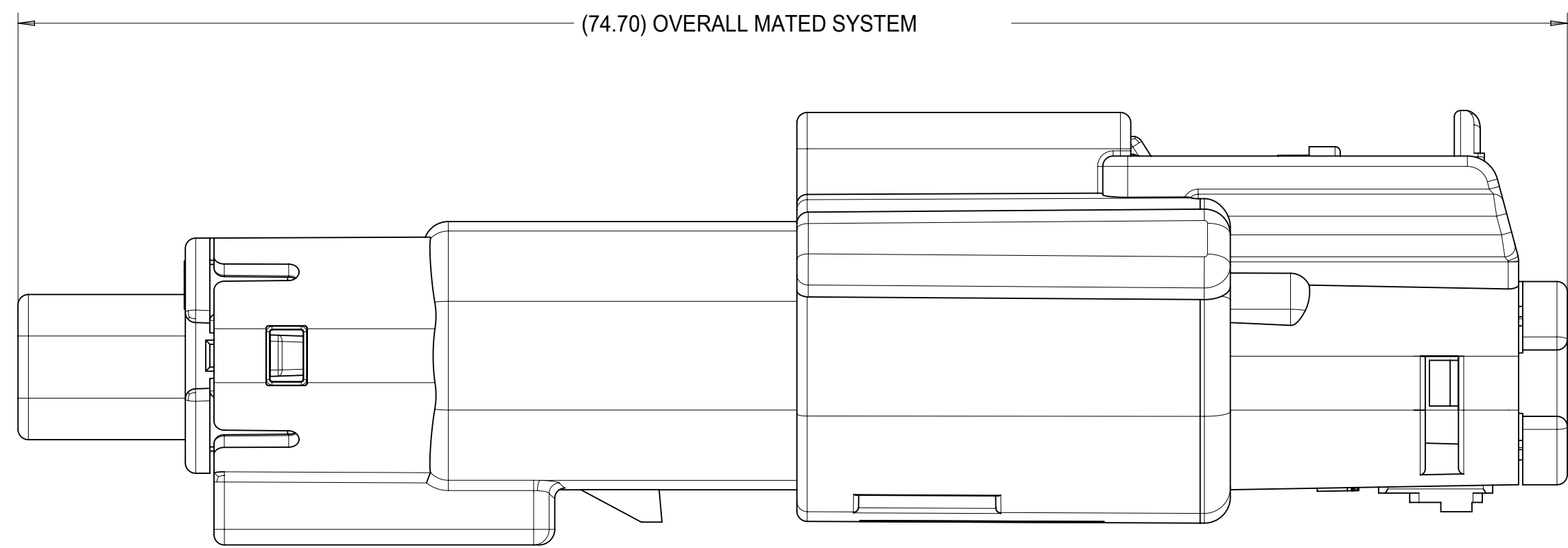

CONFIGURATION		A
MX150 1X4 RECPT SEALED ASSY - STANDARD		29.14
MX150 1X4 RECPT SEALED ASSY - ERGO		29.33
MX150 1X4 RECPT SEALED ASSY - SHORTING (SHRT) BAR		29.14

<b>QUALITY SYMBOLS</b> 	THIS DRAWING CONTAINS INFORMATION THAT IS PROPRIETARY TO MOLEX ELECTRONIC TECHNOLOGIES, LLC AND SHOULD NOT BE USED WITHOUT WRITTEN PERMISSION									
	2017/10/30	2017/10/31	GENERAL TOLERANCES (UNLESS SPECIFIED)		DIMENSION UNITS	SCALE				
	DRWN: LSONG05	CHKD: MIVANSLAMBROU	ANGULAR TOL ± 1.0 °		mm	4:1				
	EC NO: 167392 DRWN: LSONG05 CHKD: MIVANSLAMBROU REV APPR:	4 PLACES ±	DRWN BY		DATE	<b>MX150 1X4 BLADE SEALED ASSEMBLY MAT SEAL, SHORTING BAR</b>				
		3 PLACES ±	KCUNNINGHAM		2012/08/28					
		2 PLACES ± 0.1	CHKD BY		DATE					
		1 PLACE ± 0.3	MDICK		2013/03/22					
		0 PLACES ±	APPR BY		DATE					
	DRAFT WHERE APPLICABLE MUST REMAIN WITHIN DIMENSIONS	VKOSHY		2012/09/04		<b>PRODUCT CUSTOMER DRAWING</b>				
	<b>K2</b>	DRAWING SIZE	THIRD ANGLE PROJECTION		SERIES	MATERIAL NUMBER	CUSTOMER			
	D			31280	SEE BOM	GENERAL MARKET				
				DOCUMENT NUMBER	DOC TYPE	DOC PART	SHEET NUMBER			
				SD-31280-200	PSD	001	4 OF 5			

MOLEX ASSEMBLY PART NUMBER	HOUSING COLOR	KEYING OPTION	CAVITY NUMBER "X" INDICATES PLUGGED POSITION				NUMBER OF PLUGGED POSITIONS	MAT SEAL	SHORTING BAR CIRCUITS 1&2	SHORTING BAR CIRCUITS 3&4
			1	2	3	4				
31280-0436	BLACK	A					0	PRESENT	PRESENT	PRESENT
31280-0437	LIGHT GRAY	B					0	PRESENT	PRESENT	PRESENT
31280-0438	BROWN	C					0	PRESENT	PRESENT	PRESENT
31280-0439	GREEN	D					0	PRESENT	PRESENT	PRESENT
31280-0440	CUSTOM	TBD					0	PRESENT	PRESENT	PRESENT
31280-0441	BLACK	A			X	X	2	PRESENT	PRESENT	NONE
31280-0442	BLACK	A					0	NONE	PRESENT	PRESENT
31280-0443	LIGHT GRAY	B					0	NONE	PRESENT	PRESENT
31280-0444	BROWN	C					0	NONE	PRESENT	PRESENT
31280-0445	GREEN	D					0	NONE	PRESENT	PRESENT
31280-0446	BLACK	A					0	PRESENT	PRESENT	NONE
31280-0447	LIGHT GRAY	B					0	PRESENT	NONE	PRESENT
31280-0448	YELLOW	A					0	PRESENT	PRESENT	PRESENT
31280-0449	YELLOW	A				X	1	PRESENT	PRESENT	NONE
31280-0450	DARK GRAY	C					0	PRESENT	PRESENT	PRESENT
31280-0451	STONE GRAY	D					0	PRESENT	PRESENT	PRESENT

(K2)

MOLEX ASSEMBLY PART NUMBER	HOUSING COLOR	KEYING OPTION	CAVITY NUMBER "X" INDICATES PLUGGED POSITION				NUMBER OF PLUGGED POSITIONS	MAT SEAL	SHORTING BAR CIRCUITS 1&2	SHORTING BAR CIRCUITS 3&4
			1	2	3	4				
31280-4436	BLACK	A					0	PRESENT	PRESENT	PRESENT
31280-4437	LIGHT GRAY	B					0	PRESENT	PRESENT	PRESENT
31280-4438	BROWN	C					0	PRESENT	PRESENT	PRESENT
31280-4439	GREEN	D					0	PRESENT	PRESENT	PRESENT
31280-4440	CUSTOM	TBD					0	PRESENT	PRESENT	PRESENT
31280-4441	BLACK	A			X	X	2	PRESENT	PRESENT	NONE
31280-4442	BLACK	A					0	NONE	PRESENT	PRESENT
31280-4443	LIGHT GRAY	B					0	NONE	PRESENT	PRESENT
31280-4444	BROWN	C					0	NONE	PRESENT	PRESENT
31280-4445	GREEN	D					0	NONE	PRESENT	PRESENT
31280-4446	BLACK	A					0	PRESENT	PRESENT	NONE
31280-4447	LIGHT GRAY	B					0	PRESENT	NONE	PRESENT
31280-4448	YELLOW	A					0	PRESENT	PRESENT	PRESENT
31280-4449	YELLOW	A				X	1	PRESENT	PRESENT	NONE
31280-4450	DARK GRAY	C					0	PRESENT	PRESENT	PRESENT
31280-4451	STONE GRAY	D					0	PRESENT	PRESENT	PRESENT

<b>QUALITY SYMBOLS</b> 	THIS DRAWING CONTAINS INFORMATION THAT IS PROPRIETARY TO MOLEX ELECTRONIC TECHNOLOGIES, LLC AND SHOULD NOT BE USED WITHOUT WRITTEN PERMISSION										
	EC NO: 167392 DRWN: LSONG05 CHKD: REV APPR: MVANSLAMBROU	2017/10/30	2017/10/31	GENERAL TOLERANCES (UNLESS SPECIFIED)		DIMENSION UNITS	SCALE				
		ANGULAR TOL ± 1.0 °		mm	1:1						
		4 PLACES ±	DRWN BY		DATE	MX150 1X4 BLADE SEALED ASSEMBLY MAT SEAL, SHORTING BAR					
		3 PLACES ±	KCUNNINGHAM		2012/08/28						
		2 PLACES ± 0.1	CHKD BY		DATE						
	1 PLACE ± 0.3	MDICK		2013/03/22	PRODUCT CUSTOMER DRAWING						
	0 PLACES ±	APPR BY		DATE							
	DRAFT WHERE APPLICABLE MUST REMAIN WITHIN DIMENSIONS		VKOSHY		2012/09/04	SERIES	MATERIAL NUMBER	CUSTOMER			
			D		THIRD ANGLE PROJECTION	31280	SEE BOM	GENERAL MARKET			
		K2			DOCUMENT NUMBER	PSD	DOC PART	SHEET NUMBER			
					SD-31280-200	001	5 OF 5				

TABLE OF CONTENTS	
SHEET NO.	SHEET DESCRIPTION
1	NOTES AND BOM
2	CONFIGURATIONS
3-4	KEY CONFIGURATIONS
5	RECEPTACLE CONNECTOR ASSEMBLY
6	BACKSHELL NOTES
7	BACKSHELL
8	BACKSHELL CONFIGURATIONS

NOTES: VALID UNLESS OTHERWISE SPECIFIED

1. GENERAL:
- a. APPLICATION SPECIFICATION SEE: AS-33472-100  
 -CONTAINS: PRODUCT INTRODUCTION, PRODUCT SUMMARY, CONNECTOR ASSEMBLY, PACKAGING INFORMATION, CONNECTOR MATING, SERVICE INSTRUCTIONS, ELECTRICAL CONTINUITY CHECKING, CRIMPING, AND TROUBLESHOOTING.  
 -DESIGNED TO MATE WITH DEVICE OR CONNECTOR AS SPECIFIED IN THE MATING INTERFACE/CONNECTOR DRAWINGS CHART.  
 \*DENOTES DRAWINGS THAT CAN BE ACCESSED AT <http://ewcap.uscarteams.org/>.  
 -ASSEMBLY SHIPPED WITH PLR IN PRE-LOCK POSITION (SEE PLR PRE-LOCK VIEW SHEET 5).
- b. PRODUCT SPECIFICATION SEE:  
 -STANDARD CONFIGURATION: PS-33471-000  
 -UL V0 CONFIGURATION: PS-160105-0001  
 CONTAINS: PRODUCT INTRODUCTION, PRODUCT SUMMARY, RATINGS (CURRENT, TEMPERATURE, SEALING, AND FLAMMABILITY), TERMINALS, WIRE DIAMETER RANGE, PRODUCT VALIDATION, AND PRODUCT DEVIATIONS.
- c. PACKAGING SPECIFICATION PER MOLEX DRAWING; SEE PACKAGING CHART
- d. PARTS MUST BE IN COMPLIANCE TO MOLEX CHEMICAL SUBSTANCES FOR PRODUCTS AND PACKAGING SPECIFICATION: OEHS-699000-301
- e. DATA MUST BE SUBMITTED UNDER THE MOLEX PART NUMBER TO IMDS (COMPANY ID#13255)
2. DESIGN - MATERIALS:
- a. FOR BILL OF MATERIALS SEE:  
 -STANDARD CONFIGURATION SD-33471-0002  
 -UL V0 CONFIGURATION SD-160105-0002
3. DESIGN - GEOMETRY:
- a. THE 3-D CAD DATA IS BASIC (WITHOUT TOLERANCE) AND MASTER FOR THIS PART WITH THE EXCEPTION OF UNDERLINED DIMENSIONS. DIMENSIONAL INFORMATION NOT SHOWN ON THIS DRAWING IS DEFINED BY THE DATA FILE AT ITS LATEST REVISION.
- b. GEOMETRIC DIMENSIONS AND TOLERANCES PER ASME Y14.5M-2009
- c. EDGES AND UNDIMENSIONED DETAILS PER ISO13715
- d. CORNERS SHOWN AS SHARP TO BE R 0.2 MAX.
- e. LETTERING SHALL BE 0.15 MAX RAISED IN 0.25 MAX RECESS PAD. THIS INCLUDES RECYCLING CODE, CAVITY ID, VENDOR IDENTIFICATION, AND CUSTOMER MATERIAL NUMBER.
- f. VISUAL DEFECTS SHALL MEET COSMETIC STANDARD PS-45499-002 (Class B).
- g. LASER MARKING:  
 1. PART NUMBER  
 2. DAY OF THE YEAR  
 3. SHIFT  
 4. YEAR  
 FOR ADDITIONAL INFORMATION SEE SECTION 5 UNDER PROCEDURES IN ES-34735-008.

PACKAGING	
DESCRIPTION	DRAWING NO.
1X2	PK-31300-635
1X6	PK-31300-903

MATING INTERFACE/CONNECTOR DRAWINGS		
DESCRIPTION	INTERFACE DEFINITION	MOLEX INLINE
1X2	*150-S-002-1-Z05	SD-33481-0001
1X6	*150-S-006-1-Z03	SD-33481-0001

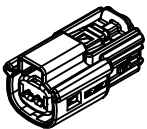

1x2

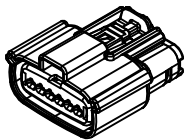
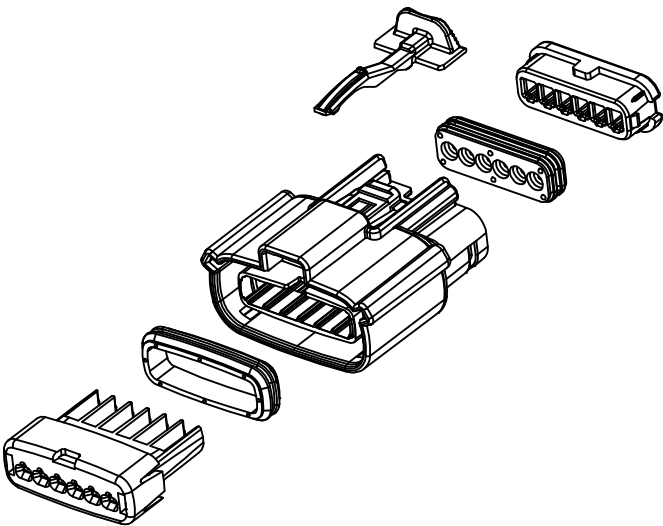

1x6

INSPECTION NUMBER LOG	2	UPDATE VIEWSETS
LAST NUMBER: 11	1	INITIAL RELEASE
ADDED: 11		
REMOVED:		
REV		REV DESCRIPTION

ENTER DESCRIPTION EEC NO: UAU2016-1641 DRWN:BTANG 2016/05/10 CHKD: APPR:KDEKOSKI 2016/06/14	QUALITY SYMBOLS ∇=0 ∇=0 ∇=0	GENERAL TOLERANCES (UNLESS SPECIFIED)		DIMENSION STYLE MM ONLY		DRAWN BY DATE APROFFITT 2015/11/04 CHECKED BY DATE APPROVED BY DATE KDEKOSKI 2016/06/14 MATERIAL NO. SEE NOTE 2a.	TITLE MX150 RCPT SINGLE ROW SEALED ASSY MAT SEAL <b>molex</b> DOCUMENT NO. SD-33471-0001	SCALE 1.5:1 DESIGN UNITS METRIC THIRD ANGLE PROJECTION	SHEET NO. 1 OF 8
		m	INCH	DRAFT WHERE APPLICABLE MUST REMAIN WITHIN DIMENSIONS					
		4 PLACES ± --- ± ---	3 PLACES ± --- ± ---	ANGULAR ± 1 °					
		2 PLACES ± 0.10 ± ---	1 PLACE ± 0.2 ± ---	THIS DRAWING CONTAINS INFORMATION THAT IS PROPRIETARY TO MOLEX INCORPORATED AND SHOULD NOT BE USED WITHOUT WRITTEN PERMISSION					

**SHEET DESCRIPTION**  
CONFIGURATIONS

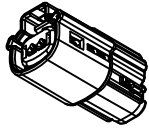

1x2 - STD

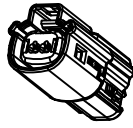

1x2 - UL V0\*

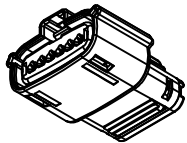

1x6 - STD

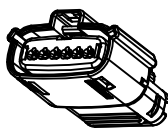

1x6 - UL V0\*

\*MINOR GEOMETRY DIFFERENCE THAN STANDARD CONFIGURATION  
SEE NOTES 1 & 2 FOR MORE INFORMATION

<b>ENTER DESCRIPTION</b> EC NO: UAU2016-1641 DRAWN BY: DRW:NB/TANG CHKD: APPR:KDEKOSKI DATE: 2016/06/14 REV: A	QUALITY SYMBOLS ▽=0 ▽=0 ▽=0	GENERAL TOLERANCES (UNLESS SPECIFIED) mm INCH 4 PLACES ± --- ± --- 3 PLACES ± --- ± --- 2 PLACES ± 0.10 ± --- 1 PLACE ± 0.2 ± --- 0 PLACE ± --- ± --- ANGULAR ± 1 °	DIMENSION STYLE <b>MM ONLY</b> DRAWN BY: APROFFITT DATE: 2015/11/04 CHECKED BY: DATE: APPROVED BY: KDEKOSKI DATE: 2016/06/14 MATERIAL NO.	SCALE: <b>1.5:1</b> DESIGN UNITS: <b>METRIC</b> THIRD ANGLE PROJECTION	TITLE: <b>MX150 RCPT SINGLE ROW SEALED ASSY MAT SEAL</b> <b>molex</b>	DOCUMENT NO. <b>SD-33471-0001</b>	SHEET NO. 2 OF 8	
	DRAFT WHERE APPLICABLE MUST REMAIN WITHIN DIMENSIONS		SEE NOTE 2a.	THIS DRAWING CONTAINS INFORMATION THAT IS PROPRIETARY TO MOLEX INCORPORATED AND SHOULD NOT BE USED WITHOUT WRITTEN PERMISSION				
	SIZE: 1							

**SHEET DESCRIPTION**  
KEY CONFIGURATIONS

1X2

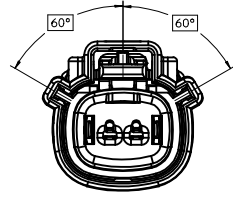

KEY A

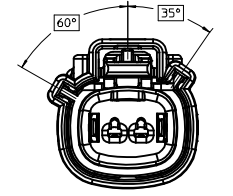

KEY B

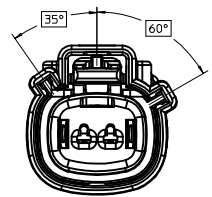

KEY C

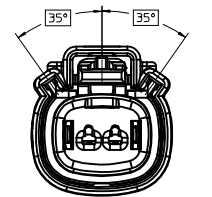

KEY D

<b>ENTER DESCRIPTION</b> EEC NO: UAU2016-1641 DRW/NXB/TANG 2016/05/10 CHKD: APPR:KDEKOSKI 2016/06/14	QUALITY SYMBOLS ▽=0 ▽=0 ▽=0	GENERAL TOLERANCES (UNLESS SPECIFIED)		DIMENSION STYLE <b>MM ONLY</b>		SCALE <b>3:1</b>	DESIGN UNITS <b>METRIC</b>	THIRD ANGLE PROJECTION	
		4 PLACES ± --- ± ---	mm	INCH	DRAWN BY APPROFIT	DATE 2015/11/04	TITLE <b>MX150 RCPT SINGLE ROW SEALED ASSY MAT SEAL</b>		
		3 PLACES ± --- ± ---			CHECKED BY	DATE			
		2 PLACES ± 0.10 ± ---			APPROVED BY KDEKOSKI	DATE 2016/06/14			
1 PLACE ± 0.2 ± ---			ANGULAR ± 1 °		MATERIAL NO.	DOCUMENT NO.		SHEET NO.	
0 PLACE ± --- ± ---	DRAFT WHERE APPLICABLE MUST REMAIN WITHIN DIMENSIONS		SEE NOTE 2a.		SD-33471-0001		3 OF 8		
				THIS DRAWING CONTAINS INFORMATION THAT IS PROPRIETARY TO MOLEX INCORPORATED AND SHOULD NOT BE USED WITHOUT WRITTEN PERMISSION					



**SHEET DESCRIPTION**  
KEY CONFIGURATIONS CONT.

1X6

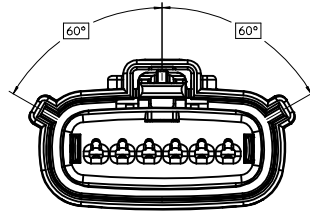

KEY A

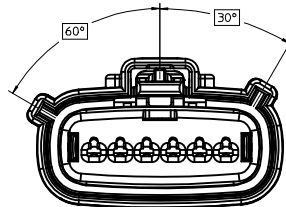

KEY B

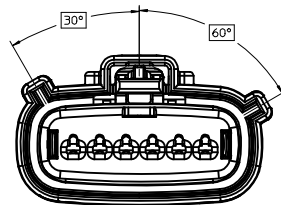

KEY C

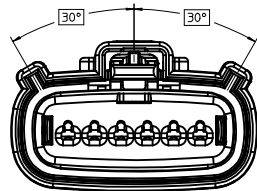

KEY D

<b>ENTER DESCRIPTION</b> EC NO: UAU2016-1641 DWN:ABTANG 2016/05/10 CHKD: APPR:KDEKOSKI 2016/06/14	QUALITY SYMBOLS ▽=0 ▽=0 ▽=0	GENERAL TOLERANCES (UNLESS SPECIFIED)		DIMENSION STYLE <b>MM ONLY</b>		SCALE <b>3:1</b>	DESIGN UNITS <b>METRIC</b>	THIRD ANGLE PROJECTION		
		4 PLACES ± --- ± ---	3 PLACES ± --- ± ---	2 PLACES ± 0.10 ± ---	1 PLACE ± 0.2 ± ---	0 PLACE ± --- ± ---	DRAWN BY APPROFFITT	DATE 2015/11/04	TITLE <b>MX150 RCPT SINGLE ROW SEALED ASSY MAT SEAL</b>	
		ANGULAR ± 1 °		DRAFT WHERE APPLICABLE MUST REMAIN WITHIN DIMENSIONS		APPROVED BY KDEKOSKI	DATE 2016/06/14	MATERIAL NO. <b>SEE NOTE 2a.</b>	DOCUMENT NO. <b>SD-33471-0001</b>	SHEET NO. <b>4 OF 8</b>
		THIS DRAWING CONTAINS INFORMATION THAT IS PROPRIETARY TO MOLEX INCORPORATED AND SHOULD NOT BE USED WITHOUT WRITTEN PERMISSION								

**SHEET DESCRIPTION**

RECEPTACLE CONNECTOR ASSEMBLY - STD

DESCRIPTION	DIMENSIONS					
	A	B	C	D	E	F
1X2	19.40	1.75	21.73	20.55	37.65	19.64
1X6	32.75	1.75	35.21	19.90	37.65	N/A
1X6 UL V0	N/A	1.75	35.23	19.90	37.65	33.64

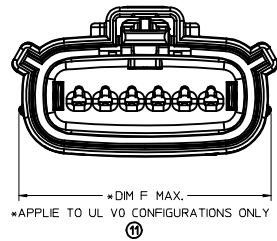

LASER MARKING ON THIS SURFACE  
SEE NOTE 3g.

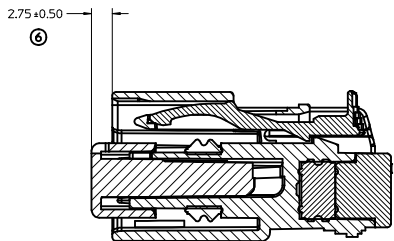
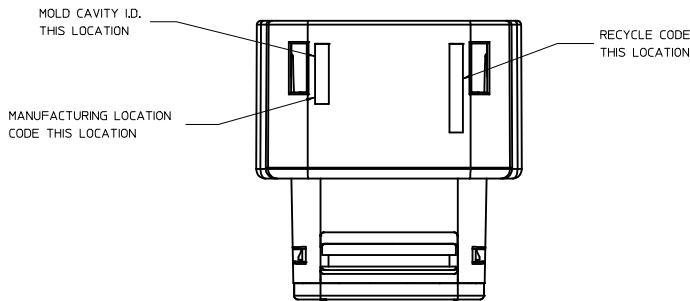
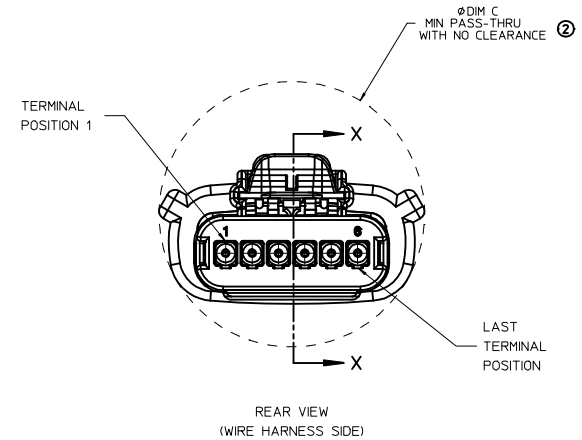
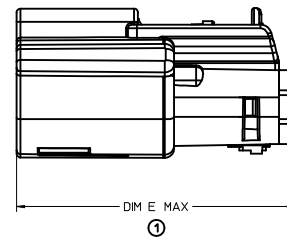
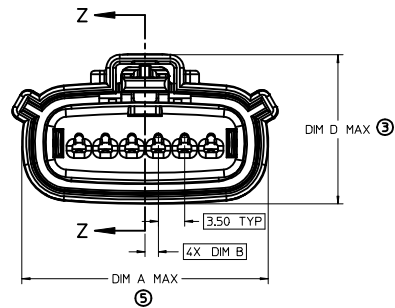
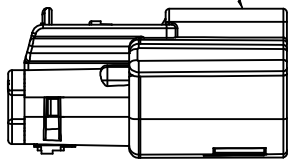

PRIMARY LOCK REINFORCEMENT (PLR) SHOWN  
IN PRE-STAGED POSITION  
SECTION Z-Z

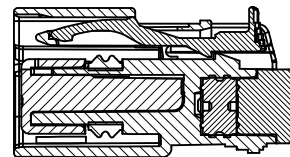

PRIMARY LOCK REINFORCEMENT (PLR) SHOWN  
IN FINAL-LOCK POSITION  
SECTION X-X

<b>ENTER DESCRIPTION</b> IEC NO: UAU2016-1641 DRYNABTANG 2016/05/10 CHYK: APPR:KDEKOSKI 2016/06/14	QUALITY SYMBOLS	GENERAL TOLERANCES (UNLESS SPECIFIED)	DIMENSION STYLE	SCALE	DESIGN UNITS	THIRD ANGLE PROJECTION
	▽=0	4 PLACES ± --- ± ---	MM ONLY	3:1	METRIC	①
	▽=0.10	3 PLACES ± --- ± ---				
	▽=0.2	2 PLACES ± 0.10 ± ---				
▽=0.5	1 PLACE ± 0.2 ± ---	ANGULAR ± 1°				
	0 PLACE ± --- ± ---	DRAFT WHERE APPLICABLE MUST REMAIN WITHIN DIMENSIONS	SEE NOTE 2a.			
			MATERIAL NO.	DOCUMENT NO.		
			SEE NOTE 2a.	SD-33471-0001		
			THIS DRAWING CONTAINS INFORMATION THAT IS PROPRIETARY TO MOLEX INCORPORATED AND SHOULD NOT BE USED WITHOUT WRITTEN PERMISSION			

**molex**

MX150 RCPT  
SINGLE ROW SEALED ASSY  
MAT SEAL

SHEET NO.  
5 OF 8

**SHEET DESCRIPTION**  
BACKSHELL NOTES

BACKSHELL NOTES: VALID UNLESS OTHERWISE SPECIFIED

1. GENERAL:  
 a. APPLICATION SPECIFICATION SEE: AS-34951-001  
 -DESIGNED TO MATE WITH RECEPTACLE SEALED ASSEMBLY SPECIFIED IN MOLEX DRAWING SD-33471-0001.  
 -SYSTEM TO BE USED WITH WIRE WITHIN DIAMETER RANGE OF 1.2mm TO 2.69mm.  
 -COMPONENTS ARE OPTIONAL AND MUST BE PURCHASED SEPERATELY.  
 -BACKSHELL DESIGN IS OWNED BY SCHLEMMER.  
 -FOR ADDITIONAL INFORMATION SEE THE BACKSHELL COMPONENT DRAWING SD-34949-0001.

BACKSHELL CUSTOMER MODEL NUMBER LEGEND

- 34949-XXXX
- CUSTOMER MODEL COMPONENTS
    - 0 - BACKSHELL ONLY
    - 1 - BACKSHELL & MX150 HOUSING KEY A ASSEMBLY
    - 2 - BACKSHELL & MX150 HOUSING KEY B ASSEMBLY
    - 3 - BACKSHELL & MX150 HOUSING KEY C ASSEMBLY
    - 4 - BACKSHELL & MX150 HOUSING KEY D ASSEMBLY
  - BACKSHELL FEATURES
    - 1 - WITH RIBS
    - 2 - WITHOUT RIBS
  - MX150 CIRCUIT SIZE 02, 03, 04, 05, 06

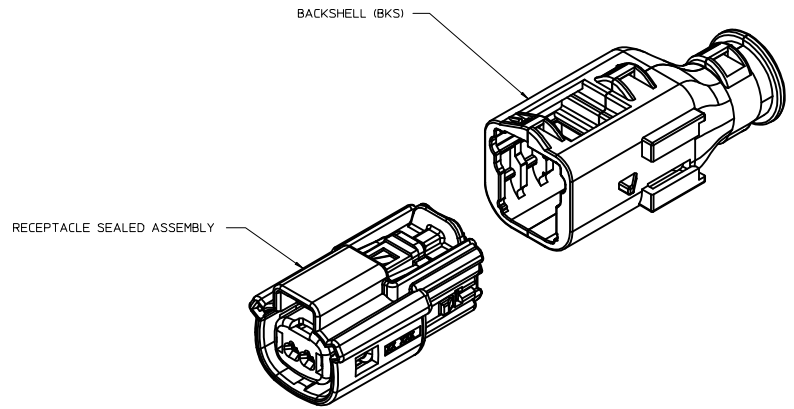
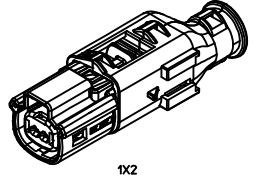

ENTER DESCRIPTION EC NO: UAUZ016-1641 DRWNR:BIANG CHKD: APPR:KDEKOSKI 2016/06/14 2016/06/14	QUALITY SYMBOLS	GENERAL TOLERANCES (UNLESS SPECIFIED)		DIMENSION STYLE <b>MM ONLY</b>		SCALE 4:1	DESIGN UNITS METRIC	THIRD ANGLE PROJECTION
	▽=0	4 PLACES ± --- ± ---	mm	INCH	DRAWN BY DATE	TITLE <b>MX150 RCPT SINGLE ROW SEALED ASSY MAT SEAL</b>	DOCUMENT NO. <b>SD-33471-0001</b>	SHEET NO. 6 OF 8
	▽=0	3 PLACES ± --- ± ---			APPROFIT 2015/11/04			
	▽=0	2 PLACES ± 0.10 ± ---			CHECKED BY DATE	MATERIAL NO. <b>SEE NOTE 2a.</b>	THIS DRAWING CONTAINS INFORMATION THAT IS PROPRIETARY TO MOLEX INCORPORATED AND SHOULD NOT BE USED WITHOUT WRITTEN PERMISSION	
▽=0	1 PLACE ± 0.2 ± ---			APPROVED BY DATE				
		0 PLACE ± --- ± ---			KDEKOSKI 2016/06/14			
		ANGULAR ± 1 °						
		DRAFT WHERE APPLICABLE MUST REMAIN WITHIN DIMENSIONS						

**SHEET DESCRIPTION**

BACKSHELL

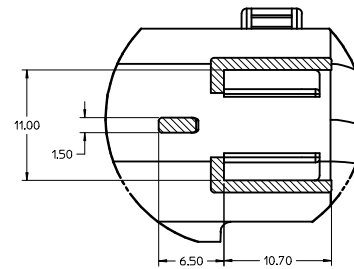
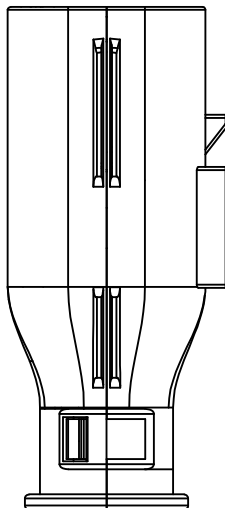
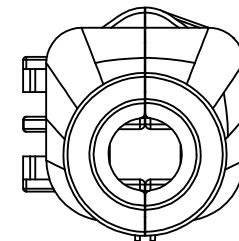
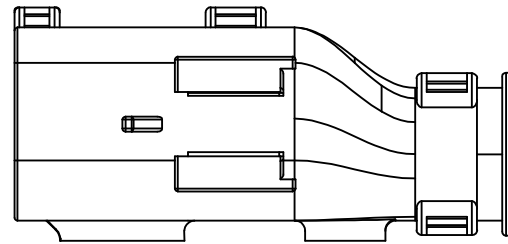
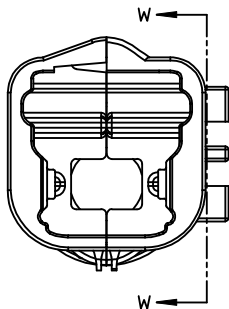
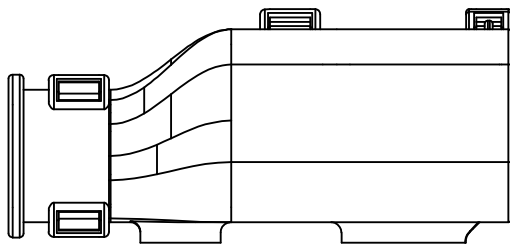

Partial W-W  
SCALE 4:1

<b>ENTER DESCRIPTION</b> EC NO: UA02016-1641 DRWN: BTANG 2016/05/10 CHKD: APPR: KDEKOSKI 2016/06/14	QUALITY SYMBOLS ∇=0 ∇=1 ∇=2 ∇=3	GENERAL TOLERANCES (UNLESS SPECIFIED) mm INCH 4 PLACES ± --- ± --- 3 PLACES ± --- ± --- 2 PLACES ± 0.10 ± --- 1 PLACE ± 0.2 ± --- 0 PLACE ± --- ± --- ANGULAR ± 1° DRAFT WHERE APPLICABLE MUST REMAIN WITHIN DIMENSIONS	DIMENSION STYLE <b>MM ONLY</b> DRAWN BY DATE APPROFIT 2015/11/04 CHECKED BY DATE APPROVED BY DATE KDEKOSKI 2016/06/14 MATERIAL NO. <b>SEE NOTE 2a.</b>	SCALE <b>4:1</b> DESIGN UNITS <b>METRIC</b> THIRD ANGLE PROJECTION	TITLE <b>MX150 RCPT                  SINGLE ROW SEALED ASSY                  MAT SEAL</b> <b>molex</b> DOCUMENT NO. <b>SD-33471-0001</b>	SHEET NO. <b>7 OF 8</b>
	REV A	DESCRIPTION	THIS DRAWING CONTAINS INFORMATION THAT IS PROPRIETARY TO MOLEX INCORPORATED AND SHOULD NOT BE USED WITHOUT WRITTEN PERMISSION	SIZE A1	SHEET NO. <b>7 OF 8</b>	SHEET NO. <b>7 OF 8</b>

**SHEET DESCRIPTION**  
BACKSHELL CONFIGURATIONS

CHARTED DIMENSIONS	
DESCRIPTION	DIMENSIONS
1X2	G
	26.00

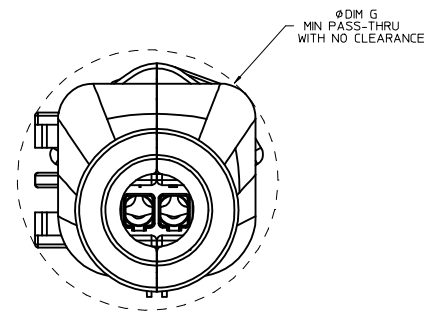
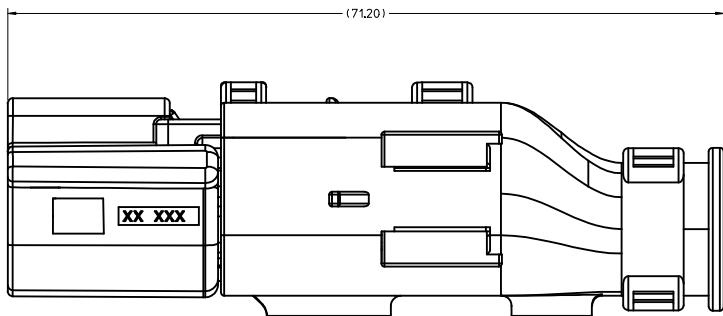

RECEPTACLE SEALED ASSEMBLY WITH RECEPTACLE BACKSHELL

<b>ENTER DESCRIPTION</b> EC NO: UAU2016-1641 DRWN: BTANG 2016/05/10 CHKD: A APPR: KDEKOSKI 2016/06/14	QUALITY SYMBOLS ∇=0 ∇=0 ∇=0 ∇=0	GENERAL TOLERANCES (UNLESS SPECIFIED)		DIMENSION STYLE <b>MM ONLY</b>		SCALE <b>4:1</b>	DESIGN UNITS <b>METRIC</b>	THIRD ANGLE PROJECTION
		4 PLACES ± --- ± --- 3 PLACES ± --- ± --- 2 PLACES ± 0.10 ± --- 1 PLACE ± 0.2 ± --- 0 PLACE ± --- ± ---	mm INCH	DRAWN BY APPROFFITT DATE 2015/11/04	CHECKED BY DATE	TITLE <b>MX150 RCPT                  SINGLE ROW SEALED ASSY                  MAT SEAL</b>		
		ANGULAR ± 1 °		APPROVED BY KDEKOSKI DATE 2016/06/14	MATERIAL NO. <b>SEE NOTE 2a.</b>		DOCUMENT NO. <b>SD-33471-0001</b>	SHEET NO. <b>8 OF 8</b>
		DRAFT WHERE APPLICABLE MUST REMAIN WITHIN DIMENSIONS		THIS DRAWING CONTAINS INFORMATION THAT IS PROPRIETARY TO MOLEX INCORPORATED AND SHOULD NOT BE USED WITHOUT WRITTEN PERMISSION				

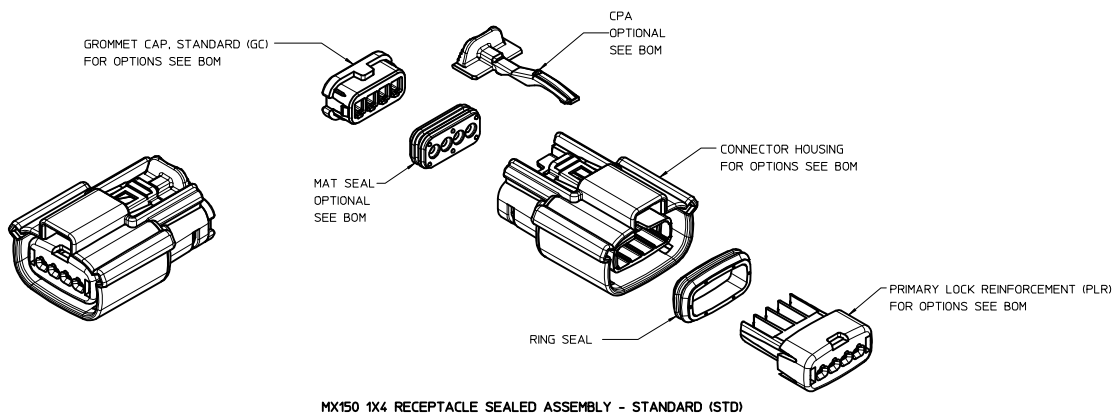

MX150 1X4 RECEPTACLE SEALED ASSEMBLY - STANDARD (STD)

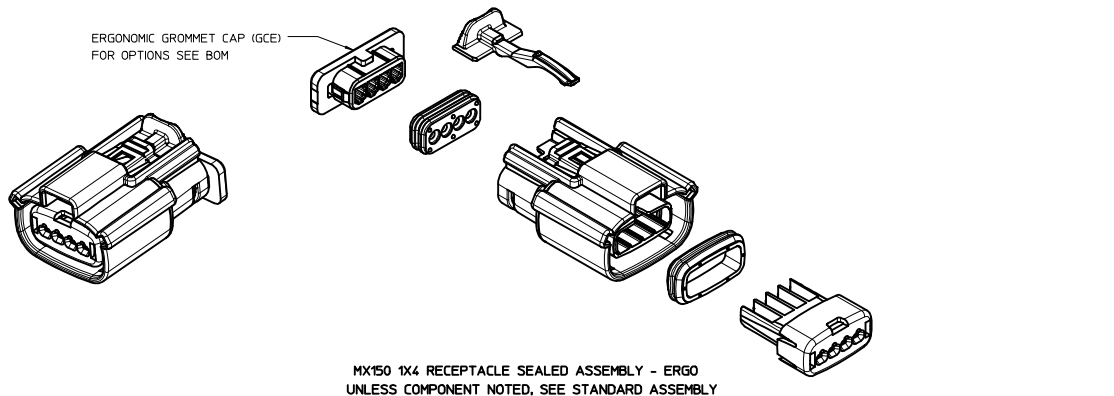

MX150 1X4 RECEPTACLE SEALED ASSEMBLY - ERGO  
UNLESS COMPONENT NOTED, SEE STANDARD ASSEMBLY

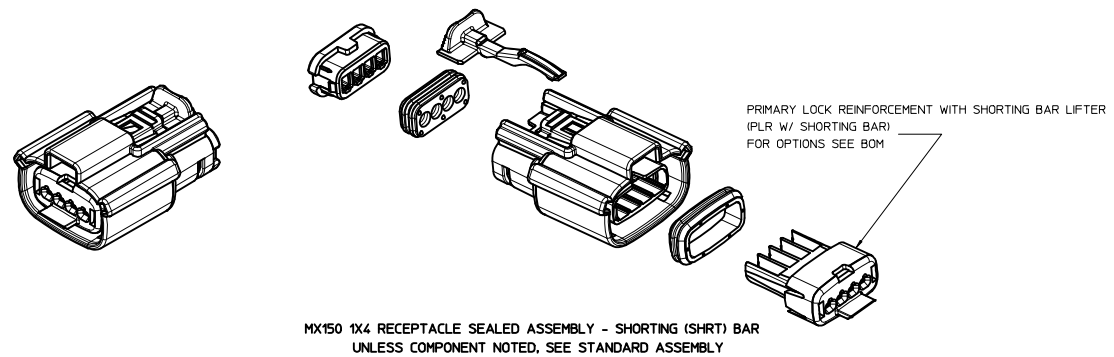

MX150 1X4 RECEPTACLE SEALED ASSEMBLY - SHORTING (SHRT) BAR  
UNLESS COMPONENT NOTED, SEE STANDARD ASSEMBLY

TABLE OF CONTENTS	
SHEET NO.	SHEET DESCRIPTION
1	NOTES
2	KEY CONFIGURATIONS
3	RECEPTACLE SEALED ASSEMBLY
4-5	BOM

NOTES: VALID UNLESS OTHERWISE SPECIFIED

1. GENERAL:
  - a. APPLICATION SPECIFICATION SEE: AS-33472-100
    - CONTAINS: PRODUCT INTRODUCTION, PRODUCT SUMMARY, CONNECTOR ASSEMBLY, PACKAGING INFORMATION, CONNECTOR MATING, SERVICE INSTRUCTIONS, ELECTRICAL CONTINUITY CHECKING, CRIMPING, AND TROUBLESHOOTING.
    - STANDARD (NON-SHRT) CONFIGURATIONS DESIGNED TO MATE WITH DEVICE CONNECTION AS SPECIFIED IN DRAWING SD-33481-041 AND EWCAP 150-S-004-1-203, AVAILABLE AT <http://ewcap.uscarteams.org/>
    - SHORTING BAR CONFIGURATIONS DESIGNED TO MATE WITH BLADE SEALED ASSEMBLY SPECIFIED IN DRAWING SD-31280-200
    - FOR 1.5mm RECEPTACLE TERMINALS TO BE USED WITH THIS ASSEMBLY, SEE MOLEX DRAWING SD-33012-002.
    - SYSTEM TO BE USED WITH WIRE WITHIN DIAMETER RANGE OF 1.2mm TO 2.69mm.
    - ASSEMBLY SHIPPED WITH PLR AND CPA IN PRE-LOCK POSITION (SEE SECTION Z-Z PRE-LOCK).
    - IN THE EVENT THAT THE PLR IS FOUND IN THE SEATED (FINAL LOCK) POSITION, REFER TO MOLEX SPECIFICATION PS-34646-001, AVAILABLE AT [www.molex.com](http://www.molex.com) <<http://www.molex.com>>.
    - ASSEMBLY CONFORMS TO SAE/USCAR-2 REV 4 WITH THE FOLLOWING EXCEPTIONS: ENGAGEMENT FORCE TO MOVE CPA FROM PRE-LOCK TO FINAL LOCK POSITION WHEN UNMATED: 40N MIN, 40N MAX.
    - DISENGAGEMENT FORCE TO MOVE CPA FROM FINAL LOCK TO PRE-LOCK POSITION: 3N MIN, 40N MAX.
    - TERMINAL INSERTION FORCE FOR WIRE DIAMETER ABOVE 2.5mm AND NOT EXCEEDING 2.69mm SHALL NOT EXCEED 40 NEWTONS.
  - b. PRODUCT SPECIFICATION SEE: PS-33471-000
    - CONTAINS: PRODUCT INTRODUCTION, PRODUCT SUMMARY, RATINGS (CURRENT, TEMPERATURE, SEALING, AND FLAMMABILITY), AND PRODUCT VALIDATION.
  - c. PACKAGING SPECIFICATION PER MOLEX DRAWING: PK-31300-903
  - d. PARTS MUST BE IN COMPLIANCE TO MOLEX CHEMICAL SUBSTANCES FOR PRODUCTS AND PACKAGING SPECIFICATION: ES-0000-5016
  - e. DATA MUST BE SUBMITTED UNDER THE MOLEX PART NUMBER TO IMDS (COMPANY ID#13255)
2. DESIGN - MATERIALS:
  - a. SEE BOM TABLE
3. DESIGN - GEOMETRY:
  - a. THIS IS A 100% CAD GENERATED PART. THE CAD MATHEMATICAL DATA IS THE MASTER FOR THIS PART. FOR DIMENSIONAL OR ANY INFORMATION NOT SHOWN ON THIS DRAWING, ANALYZE THE CAD MODEL.
  - b. GEOMETRIC DIMENSIONS AND TOLERANCES PER ASME Y14.5M - 1994
  - c. EDGES AND UNDIMENSIONED DETAILS PER ISO13715
  - d. CORNERS SHOWN AS SHARP TO BE R 0.2 MAX.
  - e. LETTERING SHALL BE 0.15 MAX RAISED IN 0.25 MAX RECESS PAD, THIS INCLUDES RECYCLING CODE, CAVITY ID, VENDOR IDENTIFICATION, AND CUSTOMER MATERIAL NUMBER.
  - f. VISUAL DEFECTS SHALL MEET COSMETIC STANDARD PS-45499-002 (Class B)
  - g. LASER MARKING: TBD

INSPECTION NUMBER LOG  
LAST NUMBER USED: 5  
ADDED:  
REMOVED: 2

W2	ADD NEW P/N 33471-0494
W1	ADD NEW P/N 33471-0493
W	REMOVE THE 33471-0489 CPA
REV	DESCRIPTION

ENTER DESCRIPTION ELEC NO: UAU2017-0052 DRAWN BY: 2016/07/17 CHKD: 2016/07/17 APPR: JDENG02 W2	QUALITY SYMBOLS ∇=0 ∇=0 ∇=0	GENERAL TOLERANCES (UNLESS SPECIFIED) DIMENSION STYLE MM ONLY	DRAWN BY DATE DGRIF1 ITHS 2010/03/31	TITLE MX150 1X4 RECEPTACLE SEALED ASSEMBLY MAT SEAL <b>molex</b> MATERIAL NO. SEE BOM DOCUMENT NO. SD-33471-041 SHEET NO. 1 OF 6
		DIMENSION STYLE MM ONLY	CHECKED BY DATE MDICK 2011/08/11	
		DIMENSION STYLE MM ONLY	APPROVED BY DATE VKOSHY 2010/04/06	
		DIMENSION STYLE MM ONLY	THIS DRAWING CONTAINS INFORMATION THAT IS PROPRIETARY TO MOLEX INCORPORATED AND SHOULD NOT BE USED WITHOUT WRITTEN PERMISSION	

KEY CONFIGURATIONS

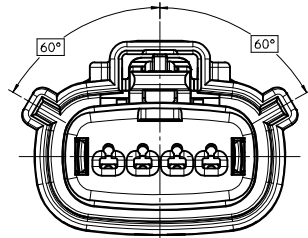

KEY A

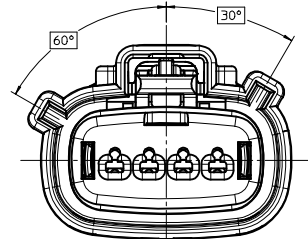

KEY B

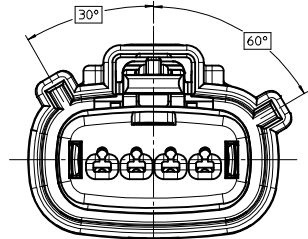

KEY C

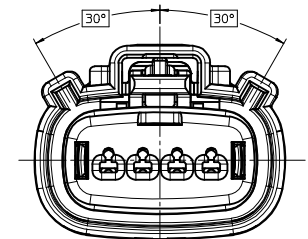

KEY D

ENTER DESCRIPTION DEC NO: UAU2017-0052 DRAWN BY CHKD: APPR: JENGOZ 2016/07/22 2016/07/27 W2	QUALITY SYMBOLS	GENERAL TOLERANCES (UNLESS SPECIFIED)	DIMENSION STYLE	SCALE	DESIGN UNITS	THIRD ANGLE PROJECTION
	▽=0	mm INCH	MM ONLY	4:1	METRIC	
	▽=0	4 PLACES ± --- ± ---	DRAWN BY DATE			TITLE
	▽=0	3 PLACES ± --- ± ---	DGRIFITHS 2010/03/31			MX150 1X4 RECEPTACLE SEALED ASSEMBLY MAT SEAL
	2 PLACES ± 0.10 ± ---	CHECKED BY DATE				
	1 PLACE ± 0.3 ± ---	MDICK 2011/08/11				
	0 PLACE ± ±	APPROVED BY DATE				
		VKOSHY 2010/04/06				
		MATERIAL NO.	SEE BOM		DOCUMENT NO.	
					SD-33471-041	SHEET NO. 2 OF 6
		DRAFT WHERE APPLICABLE MUST REMAIN WITHIN DIMENSIONS	SIZE D	THIS DRAWING CONTAINS INFORMATION THAT IS PROPRIETARY TO MOLEX INCORPORATED AND SHOULD NOT BE USED WITHOUT WRITTEN PERMISSION		

RECEPTACLE SEALED ASSEMBLY

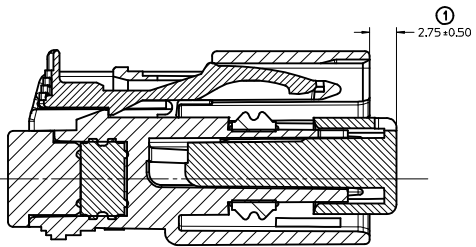
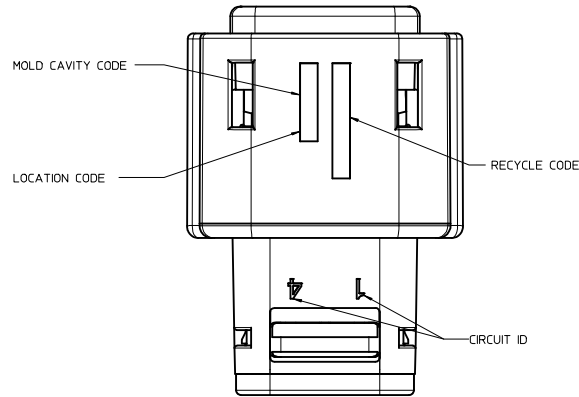
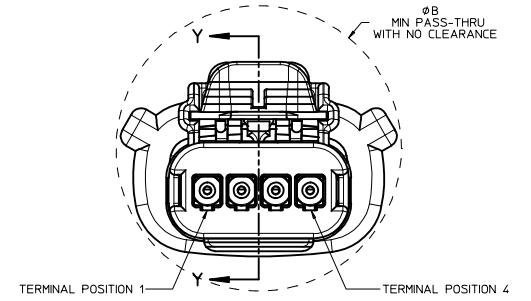
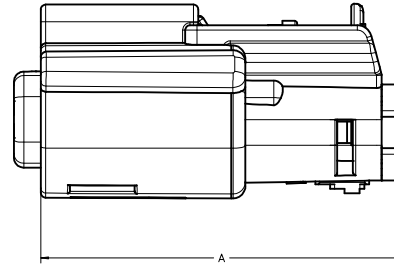
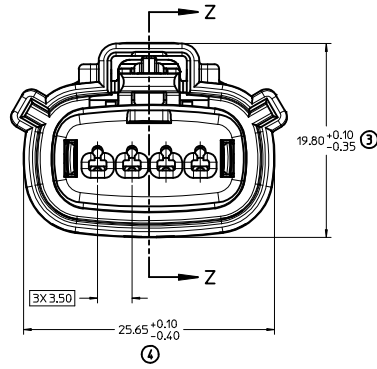
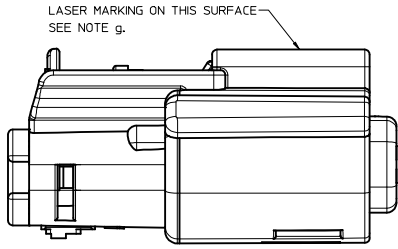

PRIMARY LOCK REINFORCEMENT (PLR) SHOWN IN PRE-STAGED POSITION

SECTION Z-Z

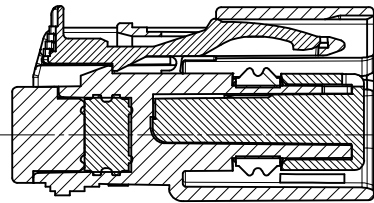

PRIMARY LOCK REINFORCEMENT (PLR) SHOWN IN FINAL-LOCK POSITION

SECTION Y-Y

CHARTED DIMENSIONS		
CONFIGURATION	A	B
MX150 1X4 RECPT SEALED ASSY - STANDARD	36.95 ±0.70	29.14
MX150 1X4 RECPT SEALED ASSY - ERGO	36.95 ±0.90	29.33
MX150 1X4 RECPT SEALED ASSY - SHORTING (SHRT) BAR	36.95 ±0.70	29.14

ENTER DESCRIPTION EC NO: UAU2017-0052 DRAWN BY: CHKD: W2 2016/07/22 2016/07/27 APPR: IDEN02	QUALITY SYMBOLS	GENERAL TOLERANCES (UNLESS SPECIFIED)	DIMENSION STYLE	SCALE	DESIGN UNITS	THIRD ANGLE PROJECTION
	▽=0	4 PLACES ± mm ± INCH	MM ONLY	4:1	METRIC	☉
	▽=0	3 PLACES ± 0.10 ± 0.3				
	▽=0	2 PLACES ± 0.3 ± 0.6				
		ANGULAR ± 3 °	DRAWN BY: DGRIFITHS	DATE: 2010/03/31	TITLE: MX150 1X4 RECEPTACLE SEALED ASSEMBLY MAT SEAL	
		DRAFT WHERE APPLICABLE MUST REMAIN WITHIN DIMENSIONS	CHECKED BY: MDICK	DATE: 2011/08/11	MATERIAL NO. SEE BOM	
			APPROVED BY: VKOSHY	DATE: 2010/04/06	DOCUMENT NO. SD-33471-041	
					SHEET NO. 3 OF 6	



ASSEMBLY DESCRIPTION	ASSEMBLY PART NUMBER	A	B	C	D	C	D	GCO	GCP	GCEO	GCEP	P	PS	M	CPA	1	2	3	4	STATUS	COMMENTS
VOID KEY	33471-0440																				
KEY D W/ SHRT. BAR, GREEN	33471-0439				D			GCO					PS	M						NOT RECOMMENDED	SEE P/N 33471-0481
KEY C W/ SHRT. BAR, BROWN	33471-0438			C				GCO					PS	M						NOT RECOMMENDED	SEE P/N 33471-0480
KEY B W/ SHRT. BAR, LT. GRAY	33471-0437			B				GCO					PS	M							
KEY A W/ SHRT. BAR, BLACK	33471-0436	A						GCO					PS	M						SALEABLE	
VOID KEY	33471-0435																				
KEY D W/O MAT SEAL, GREEN	33471-0434				D			GCO				P								NOT RECOMMENDED	SEE P/N 33471-0479
KEY C W/O MAT SEAL, BROWN	33471-0433				C			GCO				P								NOT RECOMMENDED	SEE P/N 33471-0478
KEY B W/O MAT SEAL, LT. GRAY	33471-0432			B				GCO				P								NOT VALIDATED	
KEY A W/O MAT SEAL, BLACK	33471-0431	A						GCO				P								SALEABLE	NOT VALIDATED
VOID KEY	33471-0430																				
KEY D W/ CPA, GREEN	33471-0429				D			GCP				P	M	CPA	1					NOT RECOMMENDED	SEE P/N 33471-0477
KEY C W/ CPA, BROWN	33471-0428				C			GCP				P	M	CPA	1					NOT RECOMMENDED	SEE P/N 33471-0476
KEY B W/ CPA, LT. GRAY	33471-0427			B				GCP				P	M	CPA	1						
KEY A W/ CPA, BLACK	33471-0426	A						GCP				P	M	CPA	1					SALEABLE	
VOID KEY	33471-0425																				
KEY D, GREEN	33471-0424				D			GCP				P	M		1					NOT RECOMMENDED	SEE P/N 33471-0475
KEY C, BROWN	33471-0423				C			GCP				P	M		1					NOT RECOMMENDED	SEE P/N 33471-0474
KEY B, LT. GRAY	33471-0422			B				GCP				P	M		1						
KEY A, BLACK	33471-0421	A						GCP				P	M		1					SALEABLE	
VOID KEY	33471-0420																				
KEY D W/ CPA, GREEN	33471-0419				D			GCP				P	M	CPA						NOT RECOMMENDED	SEE P/N 33471-0473
KEY C W/ CPA, BROWN	33471-0418				C			GCP				P	M	CPA						NOT RECOMMENDED	SEE P/N 33471-0472
KEY B W/ CPA, LT. GRAY	33471-0417			B				GCP				P	M	CPA							
KEY A W/ CPA, BLACK	33471-0416	A						GCP				P	M	CPA						SALEABLE	
VOID KEY	33471-0415																				
KEY D, GREEN	33471-0414				D			GCP				P	M							NOT RECOMMENDED	SEE P/N 33471-0471
KEY C, BROWN	33471-0413				C			GCP				P	M							NOT RECOMMENDED	SEE P/N 33471-0470
KEY B, LT. GRAY	33471-0412			B				GCP				P	M								
KEY A, BLACK	33471-0411	A						GCP				P	M							SALEABLE	
KEY C W/ CPA, BLACK	33471-0410				C			GCO				P	M	CPA							
KEY D W/ CPA, GREEN	33471-0409				D			GCO				P	M	CPA						NOT RECOMMENDED	SEE P/N 33471-0465
KEY C W/ CPA, BROWN	33471-0408				C			GCO				P	M	CPA						NOT RECOMMENDED	SEE P/N 33471-0464
KEY B W/ CPA, LT. GRAY	33471-0407			B				GCO				P	M	CPA							
KEY A W/ CPA, BLACK	33471-0406	A						GCO				P	M	CPA						SALEABLE	
VOID KEY	33471-0405																				
KEY D, GREEN	33471-0404				D			GCO				P	M							NOT RECOMMENDED	SEE P/N 33471-0463
KEY C, BROWN	33471-0403				C			GCO				P	M							NOT RECOMMENDED	SEE P/N 33471-0462
KEY B, LT. GRAY	33471-0402			B				GCO				P	M								
KEY A, BLACK	33471-0401	A						GCO				P	M							SALEABLE	

DESCRIPTION	COLOR	MATERIAL
RING SEAL	BURNT ORANGE	INHERENTLY LUBRICATED SILICONE
CPA	BRIGHT RED	PBT GF30
MAT SEAL	LIGHT BLUE	INHERENTLY LUBRICATED SILICONE
SHORTING BAR PLR	NATURAL	SPS/NYLON GF20
STANDARD PLR	NATURAL	SPS/NYLON GF20
ERGONOMIC GROMMET CAP, PLUGGED	BLACK	SPS/NYLON GF20
ERGONOMIC GROMMET CAP, OPEN	BLACK	SPS/NYLON GF20
STANDARD GROMMET CAP, PLUGGED	BLACK	SPS/NYLON GF20
STANDARD GROMMET CAP, OPEN	BLACK	SPS/NYLON GF20
HOUSING KEYING OPTION D	STONE GRAY	SPS/NYLON GF20
HOUSING KEYING OPTION C	DARK GRAY	SPS/NYLON GF20
HOUSING KEYING OPTION C	BLACK	SPS/NYLON GF20
HOUSING KEYING OPTION D	GREEN	SPS/NYLON GF20
HOUSING KEYING OPTION C	BROWN	SPS/NYLON GF20
HOUSING KEYING OPTION B	LIGHT GRAY	SPS/NYLON GF20
HOUSING KEYING OPTION A	BLACK	SPS/NYLON GF20

ABBREVIATION	COMPONENT
A	HOUSING KEY A
B	HOUSING KEY B
C	HOUSING KEY C
D	HOUSING KEY D
GCO	GROMMET CAP, STANDARD, OPEN
GCP	GROMMET CAP, STANDARD, PLUGGED
GCEO	GROMMET CAP, ERGONOMIC, OPEN
GCEP	GROMMET CAP, ERGONOMIC, PLUGGED
M	MAT SEAL
P	PLR, STANDARD
PS	PLR, SHRT. BAR LIFTER
R	RING SEAL
CPA	CPA

<b>ENTER DESCRIPTION</b> ELEC NO: UAU2017-0052 DRAWN BY: W2 DATE: 2016/07/22 CHKD: JDEMOZ APPR: JDEMOZ	QUALITY SYMBOLS ∇=0 ∇=0 ∇=0	GENERAL TOLERANCES (UNLESS SPECIFIED) mm    INCH 4 PLACES ±0.10 ±0.004 3 PLACES ±0.15 ±0.005 2 PLACES ±0.20 ±0.008 1 PLACE ±0.30 ±0.012 0 PLACE ±0.50 ±0.020 ANGULAR ± 3 ° DRAFT WHERE APPLICABLE MUST REMAIN WITHIN DIMENSIONS	DIMENSION STYLE MM ONLY	SCALE METRIC	DESIGN UNITS METRIC	THIRD ANGLE PROJECTION	DRAWN BY: DGRIFITHS DATE: 2010/03/31 CHECKED BY: MDICK DATE: 2011/08/11 APPROVED BY: VKOSHY DATE: 2010/04/06	TITLE MX150 1X4 RECEPTACLE SEALED ASSEMBLY MAT SEAL	MATERIAL NO. SEE BOM	DOCUMENT NO. SD-33471-041	SHEET NO. 4 OF 6
	THIS DRAWING CONTAINS INFORMATION THAT IS PROPRIETARY TO MOLEX INCORPORATED AND SHOULD NOT BE USED WITHOUT WRITTEN PERMISSION										
	MOLEX										
	W2										

ASSEMBLY DESCRIPTION	ASSEMBLY PART NUMBER	A	B	C	D	C	D	GCO	GCP	GCEO	GCEP	P	PS	M	CPA	1	2	3	4	STATUS	COMMENTS
KEY C W/ SHRT. BAR, DARK GRAY	33471-0480						C	GCO					PS	M						SALEABLE	
KEY D W/O MAT SEAL, STONE GRAY	33471-0479						D	GCO				P								SALEABLE	
KEY C W/O MAT SEAL, DARK GRAY	33471-0478						C	GCO				P								SALEABLE	
KEY D W/ CPA, STONE GRAY	33471-0477						D	GCP				P	M	CPA	1			4	SALEABLE		
KEY C W/ CPA, DARK GRAY	33471-0476						C	GCP				P	M	CPA	1			4	SALEABLE		
KEY D, STONE GRAY	33471-0475						D	GCP				P	M		1			4	SALEABLE		
KEY C, DARK GRAY	33471-0474						C	GCP				P	M		1			4	SALEABLE		
KEY D W/ CPA, STONE GRAY	33471-0473						D	GCP				P	M	CPA				4	SALEABLE		
KEY C W/ CPA, DARK GRAY	33471-0472						C	GCP				P	M	CPA				4	SALEABLE		
KEY D, STONE GRAY	33471-0471						D	GCP				P	M					4	SALEABLE		
KEY C, DARK GRAY	33471-0470						C	GCP				P	M					4	SALEABLE		
KEY A, BLACK	33471-0469	A						GCF				P	M			2		4	SALEABLE		
KEY B, W/ CPA, LIGHT GRAY	33471-0468		B					GCF				P	M	CPA		2			SALEABLE		
KEY A, BLACK	33471-0467	A						GCF				P	M				3	4	SALEABLE		
KEY B, LIGHT GRAY	33471-0466		B					GCF				P	M		1	2			SALEABLE		
KEY D W/ CPA, STONE GRAY	33471-0465						D	GCO				P	M	CPA					SALEABLE		
KEY C W/ CPA, DARK GRAY	33471-0464						C	GCO				P	M	CPA					SALEABLE		
KEY D, STONE GRAY	33471-0463						D	GCO				P	M						SALEABLE		
KEY C, DARK GRAY	33471-0462						C	GCO				P	M						SALEABLE		
KEY A W/ CPA & ERGO. CAP, BLACK	33471-0461	A							GCEO			P	M	CPA					SALEABLE		
VOID KEY	33471-0460																				
KEY A, BLACK	33471-0459	A							GCF			P	M				3		SALEABLE		
KEY A W/ SHRT. BAR, BLACK	33471-0458	A							GCF			PS	M		1			4	SALEABLE		
KEY D W/ SHRT. BAR, GREEN	33471-0457			D					GCF			PS	M					4	NOT RECOMMENDED	SEE P/N 33471-0488	
VOID KEY	33471-0456																				
KEY D W/ SHRT. BAR, GREEN	33471-0455			D					GCF			PS	M		1	2	3	4	NOT RECOMMENDED	SEE P/N 33471-0487	
KEY C W/ SHRT. BAR, BROWN	33471-0454			C					GCF			PS	M		1	2	3	4	NOT RECOMMENDED	SEE P/N 33471-0486	
KEY B W/ SHRT. BAR, LT. GRAY	33471-0453		B						GCF			PS	M		1	2	3	4	NOT RECOMMENDED	SEE P/N 33471-0487	
KEY A W/ SHRT. BAR, BLACK	33471-0452	A							GCF			PS	M		1	2	3	4	SALEABLE		
KEY A W/ SHRT. BAR, BLACK	33471-0451	A							GCF			PS	M				3	4	SALEABLE		
VOID KEY	33471-0450																				
KEY D W/ CPA & SHRT. BAR, GREEN	33471-0449			D					GCO			PS	M	CPA					NOT RECOMMENDED	SEE P/N 33471-0485	
KEY C W/ CPA & SHRT. BAR, BROWN	33471-0448			C					GCO			PS	M	CPA					NOT RECOMMENDED	SEE P/N 33471-0484	
KEY B W/ CPA & SHRT. BAR, LT. GRAY	33471-0447		B						GCO			PS	M	CPA							
KEY A W/ CPA & SHRT. BAR, BLACK	33471-0446	A							GCO			PS	M	CPA					SALEABLE		
VOID KEY	33471-0445																				
KEY D, GREEN	33471-0444			D					GCF			P	M		1	2	3	4	NOT RECOMMENDED	SEE P/N 33471-0483	
KEY C, BROWN	33471-0443			C					GCF			P	M		1	2	3	4	NOT RECOMMENDED	SEE P/N 33471-0482	
KEY B, LT. GRAY	33471-0442		B						GCF			P	M		1	2	3	4	NOT RECOMMENDED	SEE P/N 33471-0482	
KEY A, BLACK	33471-0441	A							GCF			P	M		1	2	3	4	SALEABLE		

DESCRIPTION	COLOR	MATERIAL
BLOCKED TERMINAL		
CAVITY WITH A NUMBER INDICATES BLOCKED TERMINAL POSITION		
CAVITY WITHOUT A NUMBER INDICATES OPEN TERMINAL POSITION		
RING SEAL	BURNT ORANGE	INHERENTLY LUBRICATED SILICONE
CPA	BRIGHT RED	PBT GF30
MAT SEAL	LIGHT BLUE	INHERENTLY LUBRICATED SILICONE
SHORTING BAR PLR	NATURAL	SPS/NYLON GF20
STANDARD PLR	NATURAL	SPS/NYLON GF20
ERGONOMIC GROMMET CAP, PLUGGED	BLACK	SPS/NYLON GF20
ERGONOMIC GROMMET CAP, OPEN	BLACK	SPS/NYLON GF20
STANDARD GROMMET CAP, PLUGGED	BLACK	SPS/NYLON GF20
STANDARD GROMMET CAP, OPEN	BLACK	SPS/NYLON GF20
HOUSING KEYING OPTION D	STONE GRAY	SPS/NYLON GF20
HOUSING KEYING OPTION C	DARK GRAY	SPS/NYLON GF20
HOUSING KEYING OPTION C	BLACK	SPS/NYLON GF20
HOUSING KEYING OPTION D	GREEN	SPS/NYLON GF20
HOUSING KEYING OPTION C	BROWN	SPS/NYLON GF20
HOUSING KEYING OPTION B	LIGHT GRAY	SPS/NYLON GF20
HOUSING KEYING OPTION A	BLACK	SPS/NYLON GF20

ABREVIATION	COMPONENT
A	HOUSING KEY A
B	HOUSING KEY B
C	HOUSING KEY C
D	HOUSING KEY D
GCO	GROMMET CAP, STANDARD, OPEN
GCP	GROMMET CAP, STANDARD, PLUGGED
GCEO	GROMMET CAP, ERGONOMIC, OPEN
GCEP	GROMMET CAP, ERGONOMIC, PLUGGED
M	MAT SEAL
P	PLR, STANDARD
PS	PLR, SHRT. BAR LIFTER
R	RING SEAL
CPA	CPA

<b>ENTER DESCRIPTION</b> ELC NO.: UAU2017-0052 DRAWN BY: DRANKYTE CHKD: CHKO APPR.: IDEN002 2016/07/27 2016/07/27 W2	QUALITY SYMBOLS ∇=0 ∇=0 ∇=0	GENERAL TOLERANCES (UNLESS SPECIFIED) mm INCH 4 PLACES ± --- ± --- 3 PLACES ± 0.10 ± --- 2 PLACES ± 0.3 ± --- 1 PLACE ± ± 0 PLACE ± ±	DIMENSION STYLE MM ONLY	SCALE DESIGN UNITS METRIC	THIRD ANGLE PROJECTION	DATE 2010/03/31 DATE 2011/08/11 DATE 2010/04/06	TITLE MX150 1X4 RECEPTACLE SEALED ASSEMBLY MAT SEAL	MATERIAL NO. SEE BOM	DOCUMENT NO. SD-33471-041	SHEET NO. 5 OF 6

ASSEMBLY DESCRIPTION	ASSEMBLY PART NUMBER	A	B	C	D	C	D	C	D	A	GCO	GCP	GCEO	GCEP	P	PS	M	CPA	1	2	3	4	STATUS	COMMENTS	
KEY B, LT.GRAY	33471-0494		B								GCP				P	M			2	3			SALEABLE		
KEY A W/ CPA, BLACK	33471-0493	A									GCP				P	M	CPA		2				SALEABLE		
KEY A W/ CPA & SHRT. BAR, YELLOW	33471-0492									A	GCO				PS	M	CPA						SALEABLE		
KEY A W/ CPA, YELLOW	33471-0491									A	GCO				P	M	CPA						SALEABLE		
KEY A W/ CPA, BLACK	33471-0490	A									GCP				P	M	CPA				3		SALEABLE		
KEY A - BLACK	33471-0489	A									GCP				P	M			2				SALEABLE		
KEY D W/ SHRT. BAR, STONE GRAY	33471-0488						D				GCP				PS	M					2		4	SALEABLE	
KEY D W/ SHRT. BAR, STONE GRAY	33471-0487						D				GCP				PS	M			1	2	3	4	SALEABLE		
KEY C W/ SHRT. BAR, DARK GRAY	33471-0486					C					GCP				PS	M			1	2	3	4	SALEABLE		
KEY D W/ CPA & SHRT. BAR, STONE GRAY	33471-0485						D			GCO					PS	M	CPA						SALEABLE		
KEY C W/ CPA & SHRT. BAR, DARK GRAY	33471-0484					C					GCO				PS	M	CPA						SALEABLE		
KEY D, STONE GRAY	33471-0483						D				GCP				P	M			1	2	3	4	SALEABLE		
KEY C, DARK GRAY	33471-0482					C					GCP				P	M			1	2	3	4	SALEABLE		
KEY D W/ SHRT. BAR, STONE GRAY	33471-0481						D			GCO					PS	M			1	2	3	4	SALEABLE		

W2

DESCRIPTION	COLOR	MATERIAL
RING SEAL	BURNT ORANGE	INHERENTLY LUBRICATED SILICONE
CPA	BRIGHT RED	PBT GF30
MAT SEAL	LIGHT BLUE	INHERENTLY LUBRICATED SILICONE
SHORTING BAR PLR	NATURAL	SPS/NYLON GF20
STANDARD PLR	NATURAL	SPS/NYLON GF20
ERGONOMIC GROMMET CAP, FLUGGED	BLACK	SPS/NYLON GF20
ERGONOMIC GROMMET CAP, OPEN	BLACK	SPS/NYLON GF20
STANDARD GROMMET CAP, FLUGGED	BLACK	SPS/NYLON GF20
STANDARD GROMMET CAP, OPEN	BLACK	SPS/NYLON GF20
HOUSING KEYING OPTION A	YELLOW	SPS/NYLON GF20
HOUSING KEYING OPTION D	STONE GRAY	SPS/NYLON GF20
HOUSING KEYING OPTION C	DARK GRAY	SPS/NYLON GF20
HOUSING KEYING OPTION C	BLACK	SPS/NYLON GF20
HOUSING KEYING OPTION D	GREEN	SPS/NYLON GF20
HOUSING KEYING OPTION C	BROWN	SPS/NYLON GF20
HOUSING KEYING OPTION B	LIGHT GRAY	SPS/NYLON GF20
HOUSING KEYING OPTION A	BLACK	SPS/NYLON GF20

ABBREVIATION	COMPONENT
A	HOUSING KEY A
B	HOUSING KEY B
C	HOUSING KEY C
D	HOUSING KEY D
GCO	GROMMET CAP, STANDARD, OPEN
GCP	GROMMET CAP, STANDARD, PLUGGED
GCEO	GROMMET CAP, ERGONOMIC, OPEN
GCEP	GROMMET CAP, ERGONOMIC, PLUGGED
M	MAT SEAL
P	PLR, STANDARD
PS	PLR, SHRT. BAR LIFTER
R	RING SEAL
CPA	CPA

ENTER DESCRIPTION LEC NO. UAU2017-0052 DRAWN BY W2 CHKD: APPR: JDENG02 2016/07/17 REV DESCRIPTION	QUALITY SYMBOLS ∇=0 ∇=0 ∇=0	GENERAL TOLERANCES (UNLESS SPECIFIED) 4 PLACES ± .--- ± .--- 3 PLACES ± .--- ± .--- 2 PLACES ± 0.10 ± .--- 1 PLACE ± 0.3 ± .--- 0 PLACE ± ± .--- ANGULAR ± 3 ° DRAFT WHERE APPLICABLE MUST REMAIN WITHIN DIMENSIONS	DIMENSION STYLE MM ONLY	SCALE 1:1	DESIGN UNITS METRIC	THIRD ANGLE PROJECTION
	DRAWN BY DGRIFITHS DATE 2010/03/31	CHECKED BY MDICK DATE 2011/08/11	APPROVED BY WKOSHY DATE 2010/04/06	MATERIAL NO. SEE BOM	DOCUMENT NO. SD-33471-041	TITLE MX150 1X4 RECEPTACLE SEALED ASSEMBLY MAT SEAL

19\_frame\_0\_P\_AM\_T  
Rev. G 2012/01/11

THIS DRAWING CONTAINS INFORMATION THAT IS PROPRIETARY TO MOLEX INCORPORATED AND SHOULD NOT BE USED WITHOUT WRITTEN PERMISSION

# TABLE OF CONTENTS

SHEET NO.	SHEET DESCRIPTION
1	NOTES
2	KEY CONFIGURATIONS
3	BLADE SEALED ASSEMBLY
4	SYSTEM PACKAGING
5	BOM

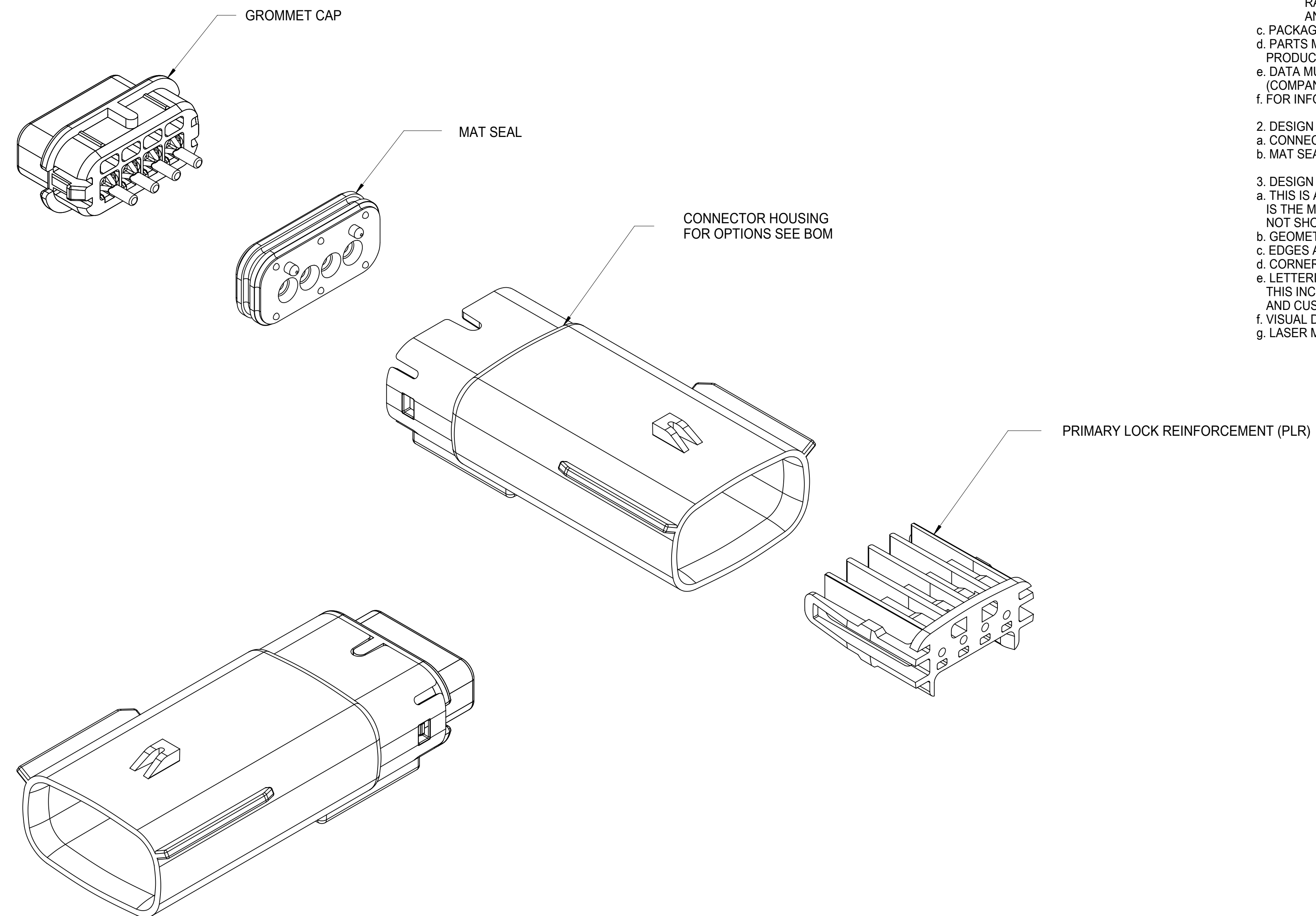

NOTES: VALID UNLESS OTHERWISE SPECIFIED

1. GENERAL:
  - a. APPLICATION SPECIFICATION SEE: AS-33472-100  
CONTAINS: PRODUCT INTRODUCTION, PRODUCT SUMMARY, CONNECTOR ASSEMBLY, PACKAGING INFORMATION, CONNECTOR MATING, SERVICE INSTRUCTIONS, ELECTRICAL CONTINUITY CHECKING, CRIMPING, AND TROUBLESHOOTING.  
-DESIGNED TO MATE WITH RECEPTACLE SEALED ASSEMBLY SPECIFIED IN MOLEX DRAWING SD-33471-041.  
-FOR 1.5mm BLADE TERMINALS TO BE USED WITH THIS ASSEMBLY SEE MOLEX DRAWING SD-33000-001.  
-SYSTEM TO BE USED WITH WIRE WITHIN DIAMETER RANGE OF 1.2mm TO 2.69mm.  
-ASSEMBLY SHIPPED WITH PLR IN PRE-LOCK POSITION  
-IN THE EVENT THAT THE PLR IS FOUND IN THE SEATED (FINAL LOCK) POSITION, REFER TO MOLEX SPECIFICATION PS-34646-001, AVAILABLE AT [www.molex.com](http://www.molex.com) <<http://www.molex.com>>  
-ASSEMBLY CONFORMS TO SAE/USCAR-2 REV.4 WITH THE FOLLOWING EXCEPTIONS: TERMINAL INSERTION FORCE FOR WIRE DIAMETER ABOVE 2.5mm NOT EXCEEDING 2.69mm SHALL NOT EXCEED 45 NEWTONS.
  - b. PRODUCT SPECIFICATION SEE: PS-33471-000  
CONTAINS: PRODUCT INTRODUCTION, PRODUCT SUMMARY, RATINGS (CURRENT, TEMPERATURE, SEALING, AND FLAMMABILITY), AND PRODUCT VALIDATION.
  - c. PACKAGING SPECIFICATION PER MOLEX DRAWING: PK-31300-635
  - d. PARTS MUST BE IN COMPLIANCE TO MOLEX CHEMICAL SUBSTANCES FOR PRODUCTS AND PACKAGING SPECIFICATION: ES-40000-5016
  - e. DATA MUST BE SUBMITTED UNDER THE MOLEX PART NUMBER TO IMDS (COMPANY ID#13255)
  - f. FOR INFORMATION ON 1X4 BLADE SEALED ASSEMBLY WITH SHORTING BAR SEE SD-31280-200.
2. DESIGN - MATERIALS:
  - a. CONNECTOR HOUSING, GROMMET CAP, PLR: SPS/NYLON BLENDED 20% GLASS FILLED
  - b. MAT SEAL: INHERENTLY LUBRICATED SILICONE
3. DESIGN - GEOMETRY:
  - a. THIS IS A 100% CAD GENERATED PART. THE CAD MATHEMATICAL DATA IS THE MASTER FOR THIS PART. FOR DIMENSIONAL OR ANY INFORMATION NOT SHOWN ON THIS DRAWING, ANALYZE THE CAD MODEL.
  - b. GEOMETRIC DIMENSIONS AND TOLERANCES PER ASME Y14.5M - 1994
  - c. EDGES AND UNDIMENSIONED DETAILS PER ISO13715
  - d. CORNERS SHOWN AS SHARP TO BE R 0.2 MAX.
  - e. LETTERING SHALL BE 0.15 MAX RAISED IN 0.25 MAX RECESS PAD. THIS INCLUDES RECYCLING CODE, CAVITY ID, VENDOR IDENTIFICATION, AND CUSTOMER MATERIAL NUMBER.
  - f. VISUAL DEFECTS SHALL MEET COSMETIC STANDARD PS-45499-002 (Class B)
  - g. LASER MARKING: TBD

SYMBOLS	THIS DRAWING CONTAINS INFORMATION THAT IS PROPRIETARY TO MOLEX ELECTRONIC TECHNOLOGIES, LLC AND SHOULD NOT BE USED WITHOUT WRITTEN PERMISSION		
	DIMENSION UNITS	SCALE	CURRENT REV DESC:
= 0	mm	3:1	EC NO: 607930 DRWN: HKLIANG 2018/11/09 CHK'D: JDENG02 2018/12/04 APPR: JDENG02 2018/12/04 INITIAL REVISION: DRWN: DGRIFITHS 2005/08/26 APPR: smarceau 2005/08/29
= 0	GENERAL TOLERANCES (UNLESS SPECIFIED)		
= 0	ANGULAR TOL ± 3.0°		
= 0	4 PLACES ±		
= 0	3 PLACES ±		
= 0	2 PLACES ± 0.1		
= 0	1 PLACE ± 0.3		DOCUMENT NUMBER <b>SD-33481-041</b>
= 0	0 PLACES ±		
= 0	DRAFT WHERE APPLICABLE MUST REMAIN WITHIN DIMENSIONS	THIRD ANGLE PROJECTION	DOC PART 001
= 0	D-DRAWING	SERIES 33481	REVISION W2
		MATERIAL NUMBER	CUSTOMER
		GENERAL MARKET	
		SHEET NUMBER 1 OF 5	

KEY CONFIGURATIONS

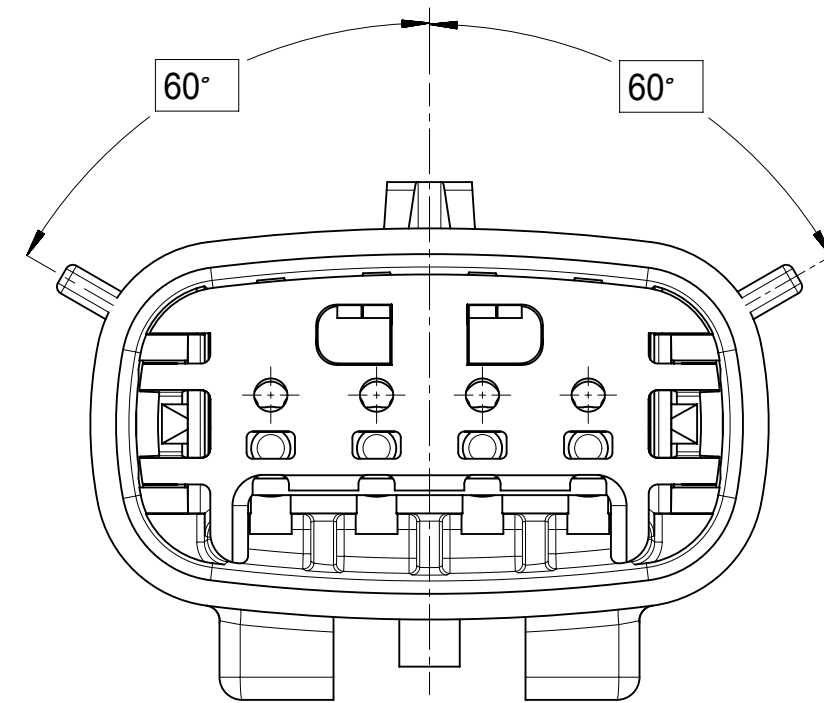

KEY A

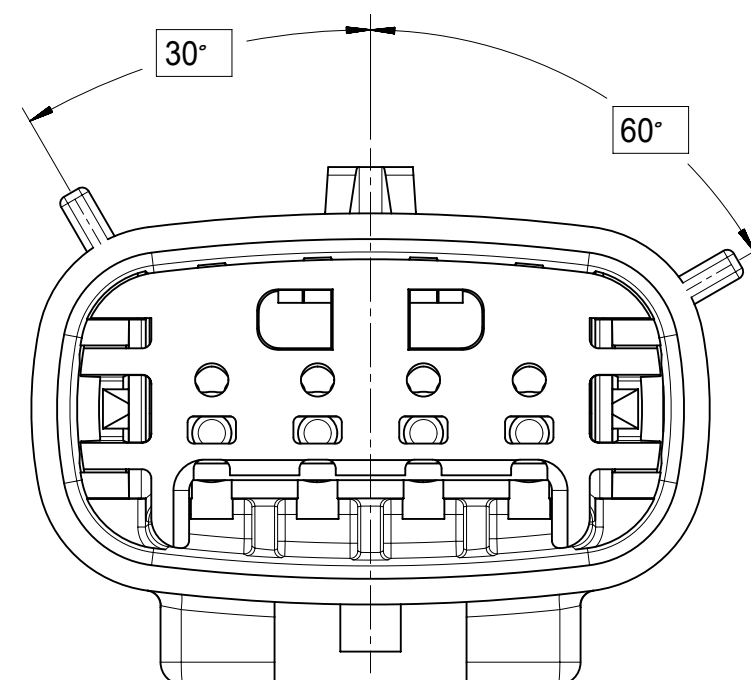

KEY B

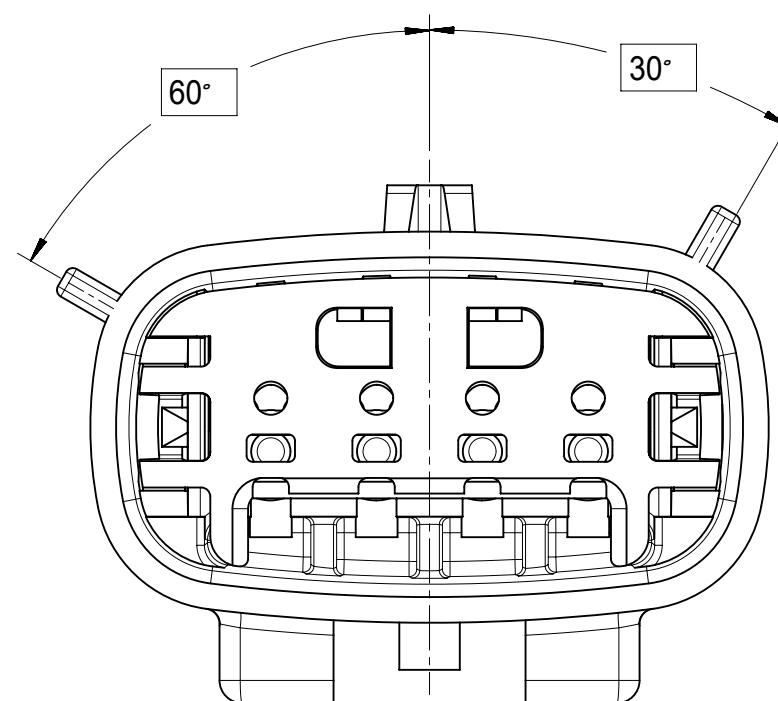

KEY C

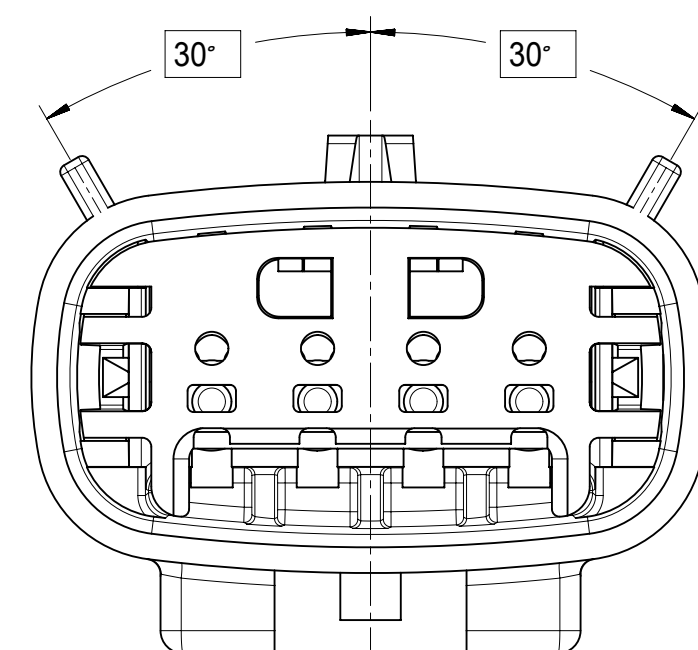

KEY D

SYMBOLS	THIS DRAWING CONTAINS INFORMATION THAT IS PROPRIETARY TO MOLEX ELECTRONIC TECHNOLOGIES, LLC AND SHOULD NOT BE USED WITHOUT WRITTEN PERMISSION		
	DIMENSION UNITS	SCALE	CURRENT REV DESC:
= 0	mm	4:1	EC NO: 607930 DRWN: HKLIANG 2018/11/09 CHK'D: JDENG02 2018/12/04 APPR: JDENG02 2018/12/04
= 0	GENERAL TOLERANCES (UNLESS SPECIFIED)		
= 0	ANGULAR TOL ± 3.0°		INITIAL REVISION: DRWN: DGRIFITHS 2005/08/26 APPR: smarceau 2005/08/29
= 0	4 PLACES ±		
= 0	3 PLACES ±		DOCUMENT NUMBER: SD-33481-041   DOC TYPE: PSD   DOC PART: 001   REVISION: W2
= 0	2 PLACES ± 0.1		
= 0	1 PLACE ± 0.3		MATERIAL NUMBER: GENERAL MARKET   CUSTOMER:   SHEET NUMBER: 2 OF 5
= 0	0 PLACES ±		
= 0	DRAFT WHERE APPLICABLE MUST REMAIN WITHIN DIMENSIONS	THIRD ANGLE PROJECTION	DRAWING: D-SIZE   SERIES: 33481
= 0			

**molex**

MX150 1X4 BLADE  
SEALED ASSEMBLY MAT SEAL

PRODUCT CUSTOMER DRAWING

DOCUMENT NUMBER: SD-33481-041 | DOC TYPE: PSD | DOC PART: 001 | REVISION: W2

MATERIAL NUMBER: GENERAL MARKET | CUSTOMER: | SHEET NUMBER: 2 OF 5

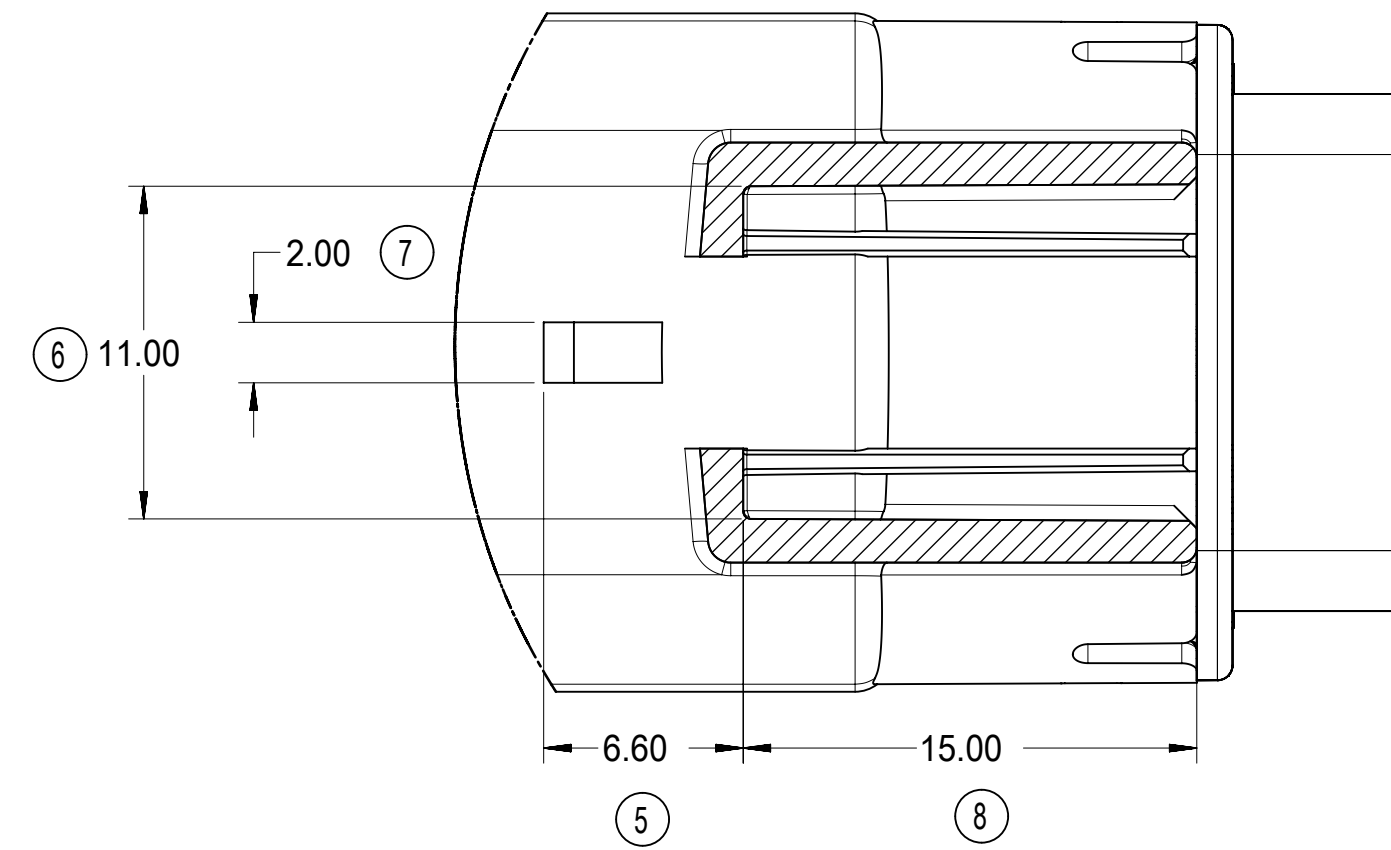
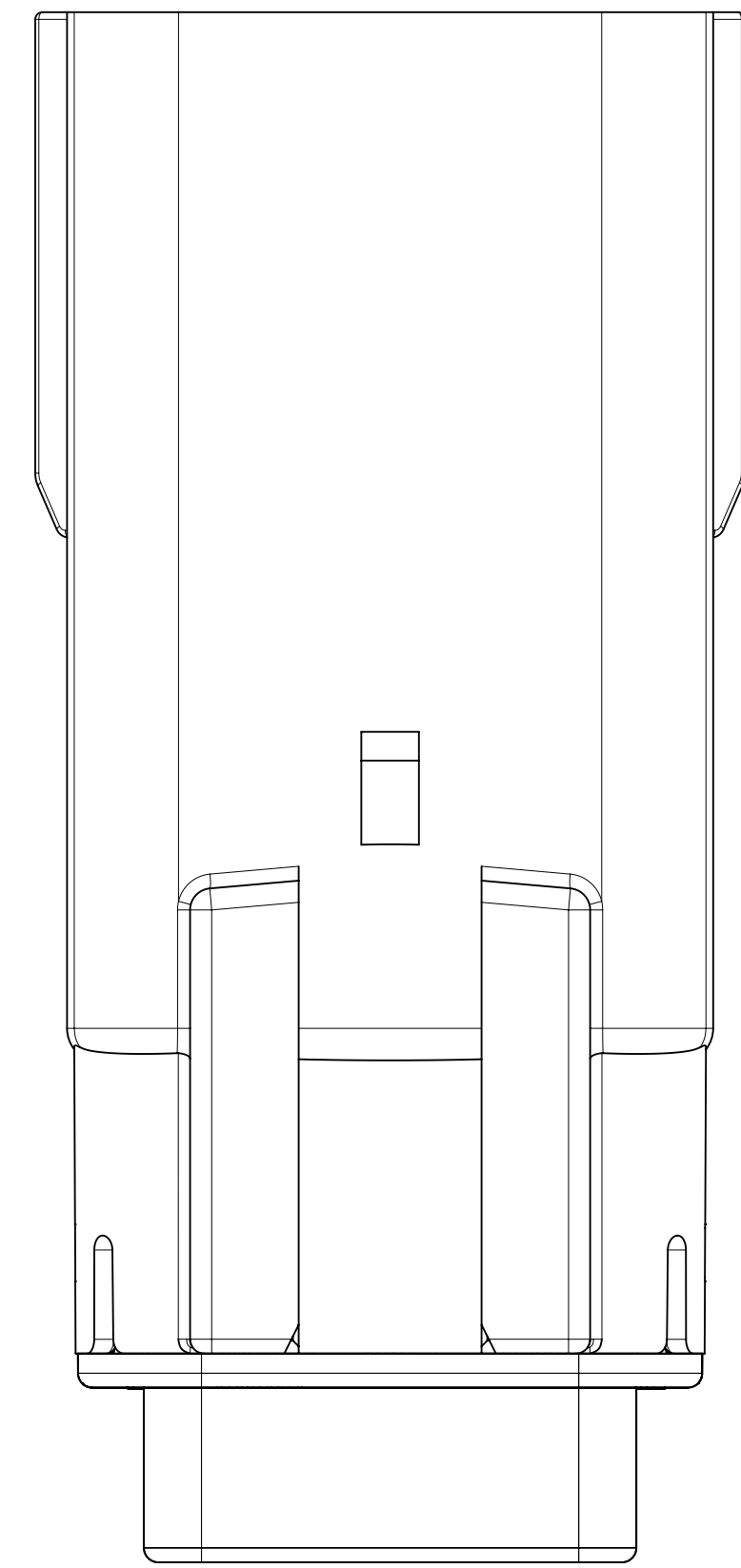
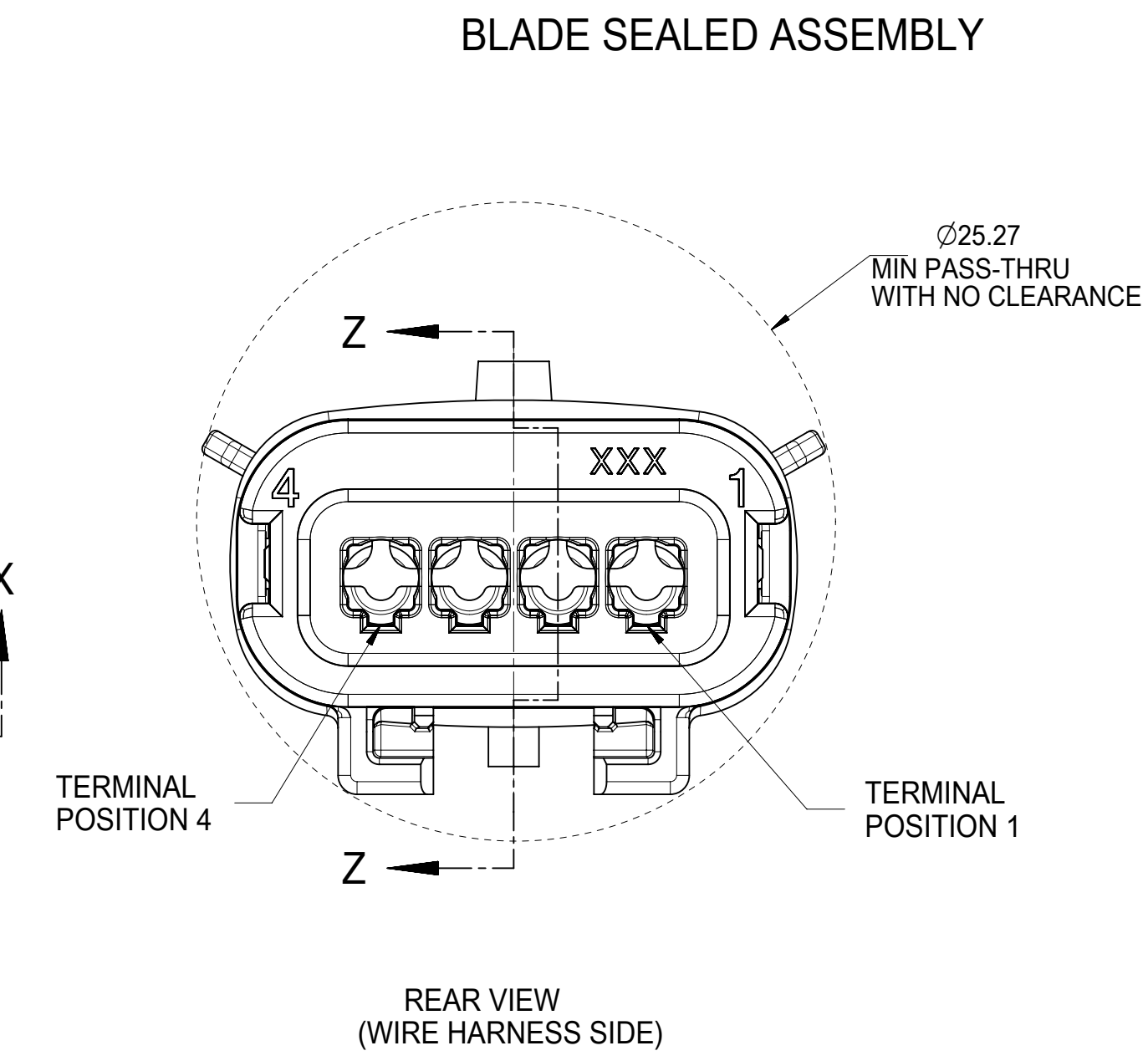
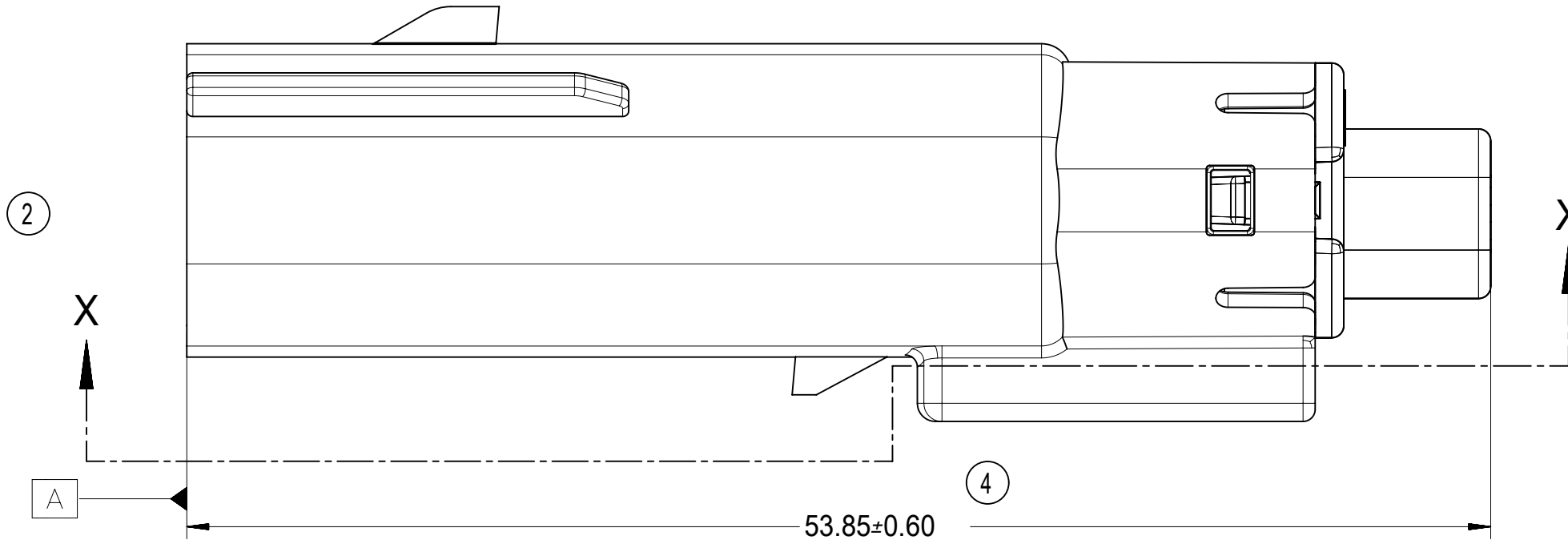
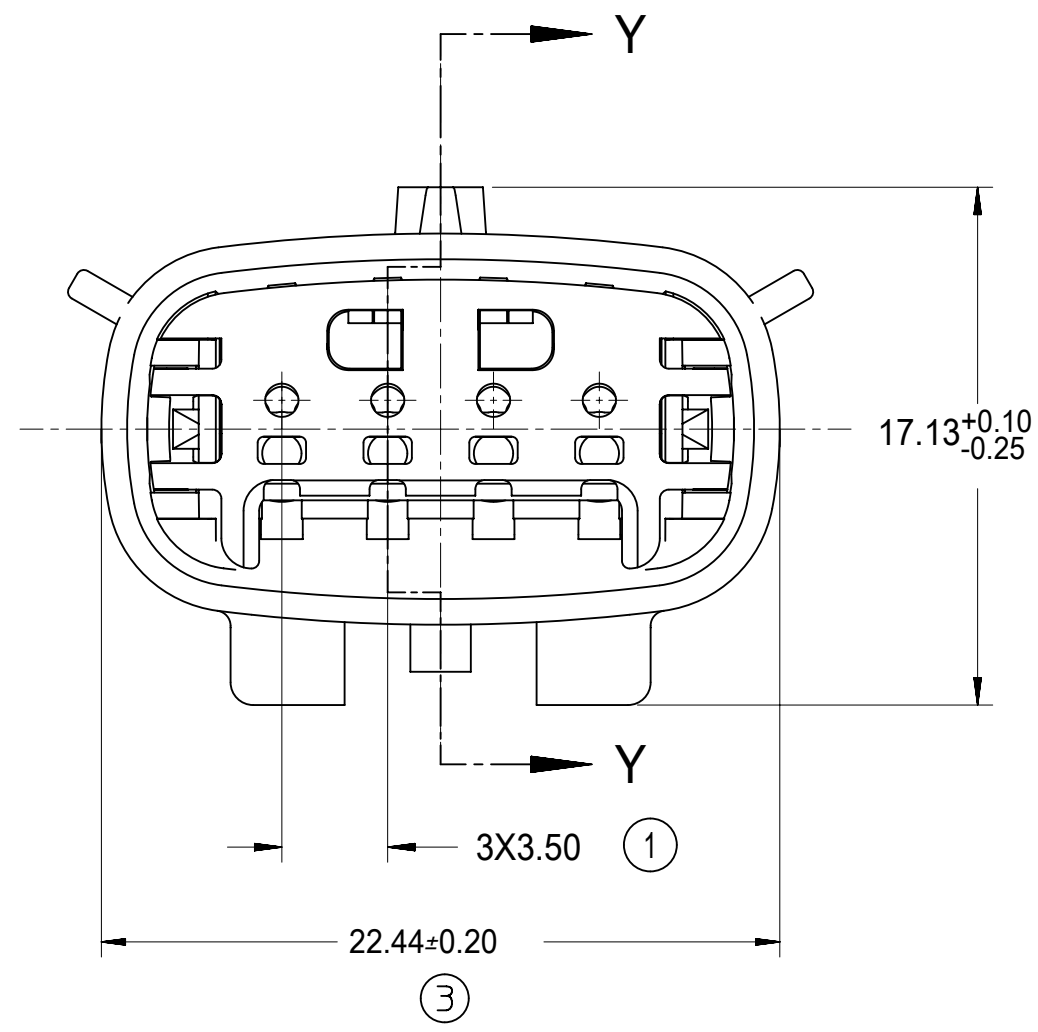
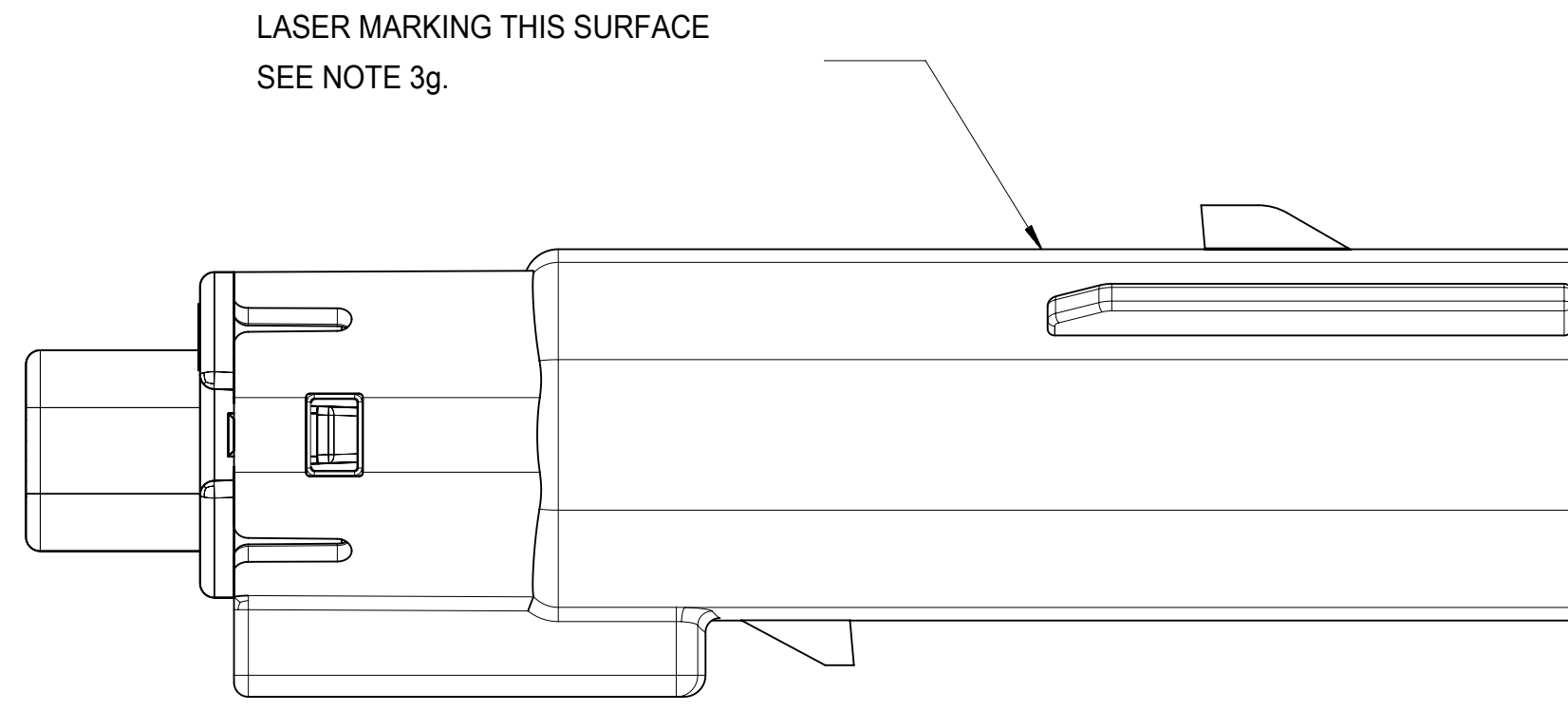

PARTIAL X-X  
SCALE 4:1

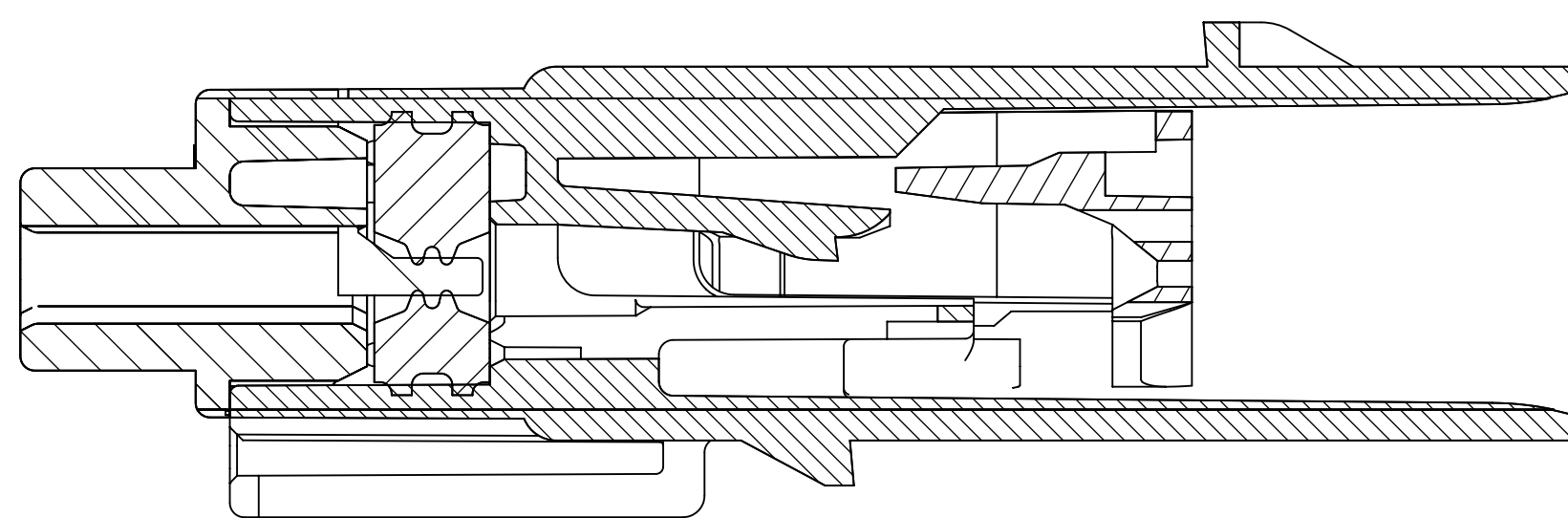

PRIMARY LOCK REINFORCEMENT (PLR) SHOWN  
IN PRE-STAGED POSITION

SECTION Z-Z

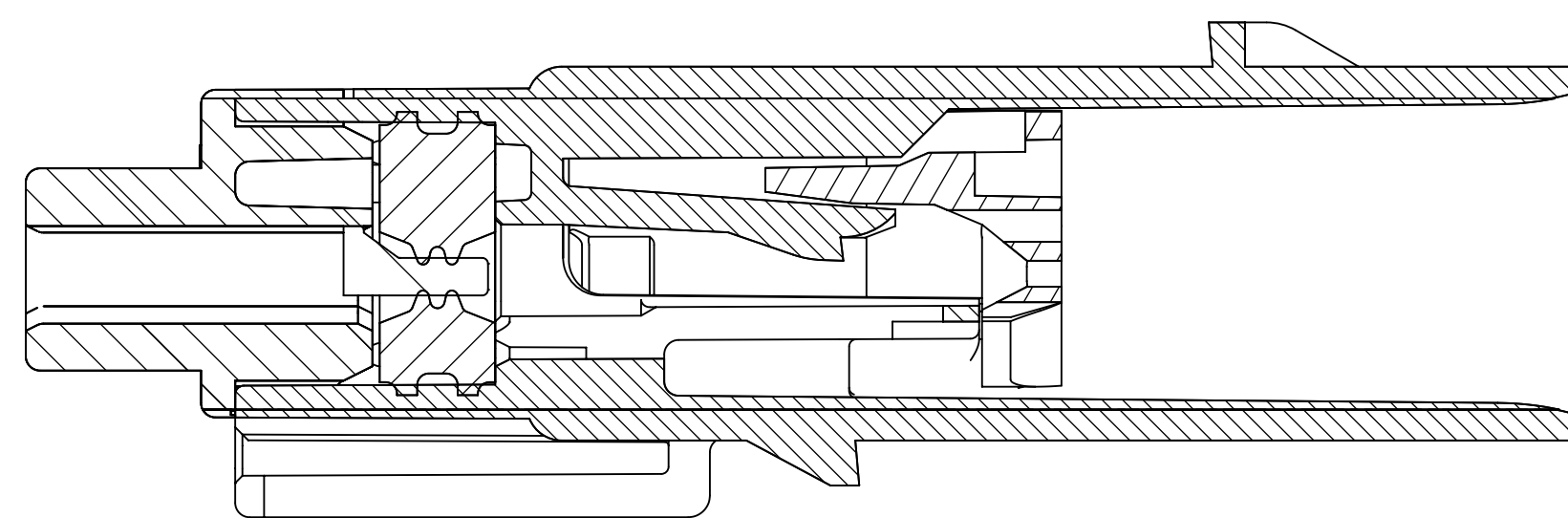

PRIMARY LOCK REINFORCEMENT (PLR) SHOWN  
IN FINAL-LOCK POSITION

SECTION Y-Y

SYMBOLS	THIS DRAWING CONTAINS INFORMATION THAT IS PROPRIETARY TO MOLEX ELECTRONIC TECHNOLOGIES, LLC AND SHOULD NOT BE USED WITHOUT WRITTEN PERMISSION			
	DIMENSION UNITS	SCALE	CURRENT REV DESC:	
▽ = 0	mm	4:1	EC NO: 607930	
▽ = 0	GENERAL TOLERANCES (UNLESS SPECIFIED)		DRWN: HKLIANG	2018/11/09
▽ = 0	ANGULAR TOL ± 3.0°		CHK'D: JDENG02	2018/12/04
▽ = 0	4 PLACES ±		APPR: JDENG02	2018/12/04
▽ = 0	3 PLACES ±		INITIAL REVISION:	
▽ = 0	2 PLACES ± 0.1		DRWN: DGRIFITHS	2005/08/26
▽ = 0	1 PLACE ± 0.3		APPR: smarceau	2005/08/29
▽ = 0	0 PLACES ±		THIRD ANGLE PROJECTION	
□ = 0	DRAFT WHERE APPLICABLE MUST REMAIN WITHIN DIMENSIONS		DRAWING	SERIES
▽ = 0			D-SIZE	33481
DOCUMENT STATUS		P1	RELEASE DATE	2018/12/04 17:46:22
DOCUMENT NUMBER		DOC TYPE		DOC PART
SD-33481-041		PSD		001
MATERIAL NUMBER		CUSTOMER		REVISION
GENERAL MARKET		GENERAL MARKET		W2
SHEET NUMBER		SHEET NUMBER		3 OF 5

**molex**

MX150 1X4 BLADE  
SEALED ASSEMBLY MAT SEAL

PRODUCT CUSTOMER DRAWING

DOCUMENT NUMBER: SD-33481-041  
DOC TYPE: PSD  
DOC PART: 001  
REVISION: W2

MATERIAL NUMBER: GENERAL MARKET  
CUSTOMER: GENERAL MARKET  
SHEET NUMBER: 3 OF 5

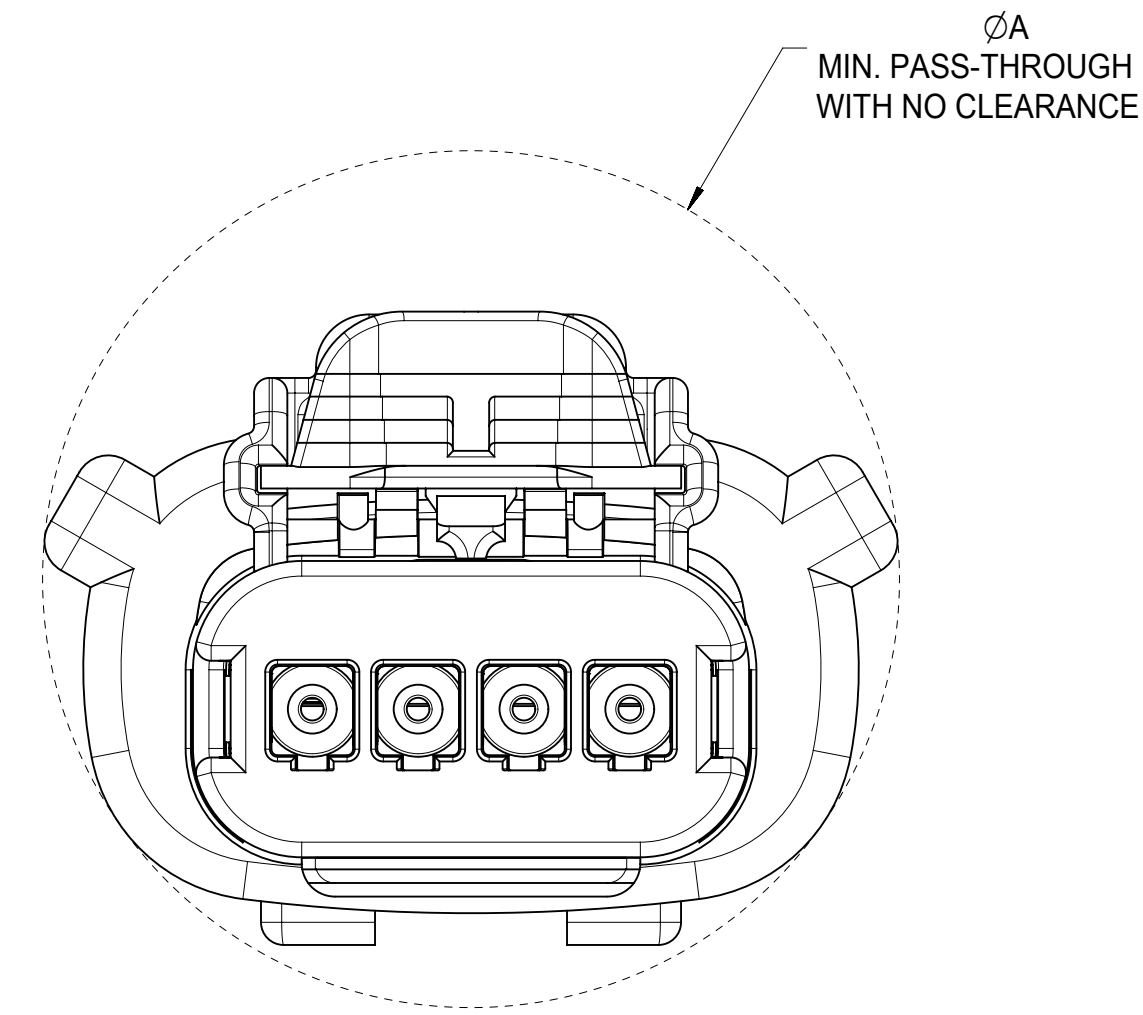
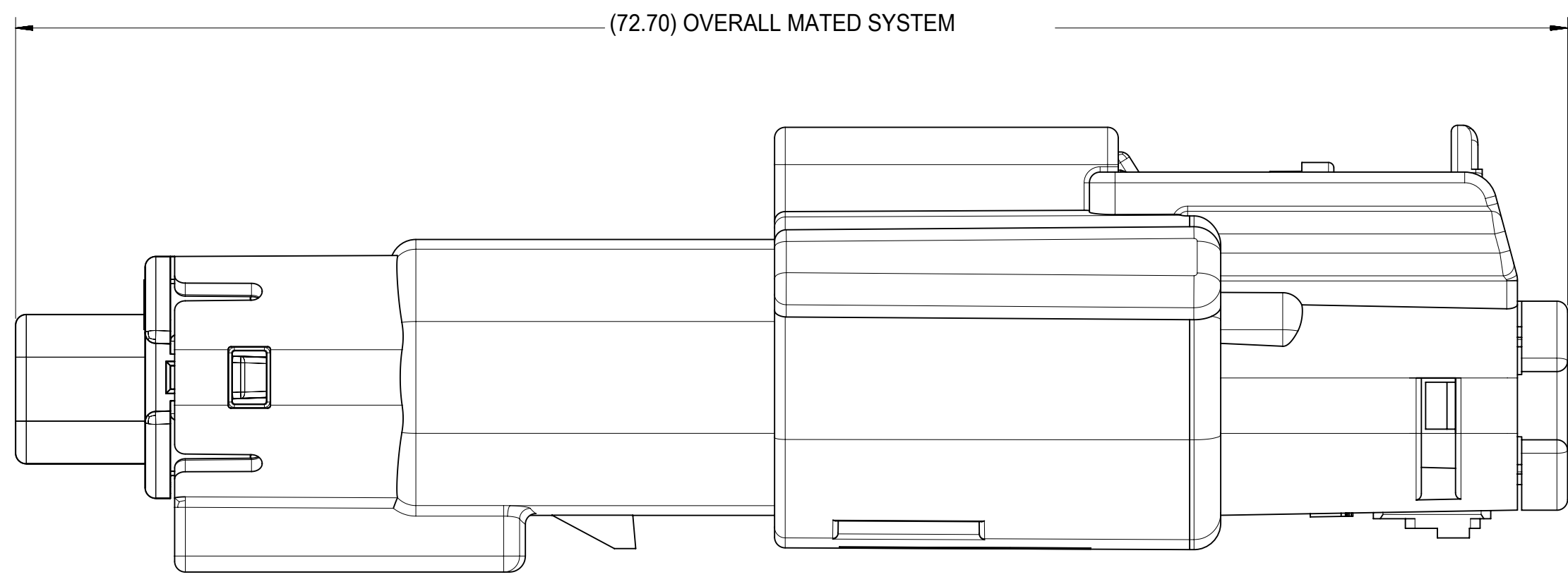

CONFIGURATION		A
MX150 1X4 RECPT SEALED ASSY - STANDARD		29.14
MX150 1X4 RECPT SEALED ASSY - ERGO		29.33
MX150 1X4 RECPT SEALED ASSY - SHORTING (SHRT) BAR		29.14

THIS DRAWING CONTAINS INFORMATION THAT IS PROPRIETARY TO MOLEX ELECTRONIC TECHNOLOGIES, LLC AND SHOULD NOT BE USED WITHOUT WRITTEN PERMISSION									
SYMBOLS	DIMENSION UNITS	SCALE	CURRENT REV DESC:						
	mm	4:1							
▽ = 0	GENERAL TOLERANCES (UNLESS SPECIFIED)		EC NO: 607930						
▽ = 0	ANGULAR TOL ± 3.0°		DRWN: HKLIANG 2018/11/09						
▽ = 0	4 PLACES ±	CHK'D: JDENG02 2018/12/04							
▽ = 0	3 PLACES ±	APPR: JDENG02 2018/12/04							
▽ = 0	2 PLACES ± 0.1	INITIAL REVISION:							
▽ = 0	1 PLACE ± 0.3	DRWN: DGRIFITHS 2005/08/26							
▽ = 0	0 PLACES ±	APPR: smarceau 2005/08/29							
□ = 0	DRAFT WHERE APPLICABLE	THIRD ANGLE PROJECTION	DRAWING	SERIES	MATERIAL NUMBER	CUSTOMER	SHEET NUMBER		
■ = 0	MUST REMAIN WITHIN DIMENSIONS		D-SIZE	33481		GENERAL MARKET	4 OF 5		

**molex**

MX150 1X4 BLADE SEALED ASSEMBLY MAT SEAL

PRODUCT CUSTOMER DRAWING



DOCUMENT NUMBER	DOC TYPE	DOC PART	REVISION
SD-33481-041	PSD	001	W2

ASSEMBLY PART NUMBER	COLOR	KEYING OPTION	CAVITY TYPE & STATUS (X = PLUGGED)				STATUS	COMMENTS
			1	2	3	4		
33481-0401	BLACK	A						
33481-0402	LT. GRAY	B						
33481-0403	BROWN	C						NOT RECOMMENDED, SEE P/N 33481-0424
33481-0404	GREEN	D						NOT RECOMMENDED, SEE P/N 33481-0425
33481-0405	BLACK	C						
33481-0406	BLACK	A				X		
33481-0407	LT. GRAY	B				X		
33481-0408	BROWN	C				X		
33481-0409	GREEN	D				X		
33481-0410	CUSTOM	TBD				X		
33481-0411	BLACK	A	X			X		
33481-0412	LT. GRAY	B	X			X		
33481-0413	BROWN	C	X			X		
33481-0414	GREEN	D	X			X		
33481-0415	CUSTOM	TBD	X			X		
33481-0416	BLACK	A	X	X	X	X		
33481-0417	LT. GRAY	B	X	X	X	X		
33481-0418	BROWN	C	X	X	X	X		NOT RECOMMENDED, SEE P/N 33481-0426
33481-0419	GREEN	D	X	X	X	X		NOT RECOMMENDED, SEE P/N 33481-0427
33481-0420	CUSTOM	TBD	X	X	X	X		
33481-0421	BLACK	A			X			
33481-0422	BLACK	A			X	X		
33481-0423	LT. GRAY	B	X	X				
33481-0424	DK. GRAY	C						
33481-0425	ST. GRAY	D						
33481-0426	DK. GRAY	C	X	X	X	X		
33481-0427	ST. GRAY	D	X	X	X	X		
33481-0428	YELLOW	A						
33481-0429	LT. GRAY	B		X	X			
33481-0430	BLACK	A	X		X			

W2

ASSEMBLY PART NUMBER	COLOR	KEYING OPTION	CAVITY TYPE & STATUS (X = PLUGGED)				STATUS	COMMENTS
			1	2	3	4		
33481-4401	BLACK	A						
33481-4402	LT. GRAY	B						
33481-4403	BROWN	C						NOT RECOMMENDED, SEE P/N 33481-4424
33481-4404	GREEN	D						NOT RECOMMENDED, SEE P/N 33481-4425
33481-4405	BLACK	C						
33481-4406	BLACK	A				X		
33481-4407	LT. GRAY	B				X		
33481-4408	BROWN	C				X		
33481-4409	GREEN	D				X		
33481-4410	CUSTOM	TBD				X		
33481-4411	BLACK	A	X			X		
33481-4412	LT. GRAY	B	X			X		
33481-4413	BROWN	C	X			X		
33481-4414	GREEN	D	X			X		
33481-4415	CUSTOM	TBD	X			X		
33481-4416	BLACK	A	X	X	X	X		
33481-4417	LT. GRAY	B	X	X	X	X		
33481-4418	BROWN	C	X	X	X	X		NOT RECOMMENDED, SEE P/N 33481-4426
33481-4419	GREEN	D	X	X	X	X		NOT RECOMMENDED, SEE P/N 33481-4427
33481-4420	CUSTOM	TBD	X	X	X	X		
33481-4421	BLACK	A			X			
33481-4422	BLACK	A			X	X		
33481-4423	LT. GRAY	B	X	X				
33481-4424	DK. GRAY	C						
33481-4425	ST. GRAY	D						
33481-4426	DK. GRAY	C	X	X	X	X		
33481-4427	ST. GRAY	D	X	X	X	X		
33481-4428	YELLOW	A						
33481-4429	LT. GRAY	B		X	X			
33481-4430	BLACK	A	X		X			

W2

<b>SYMBOLS</b> ▽ = 0 ▽ = 0 ▽ = 0 ▽ = 0 ▽ = 0 ▽ = 0 ▽ = 0 ▽ = 0 ▽ = 0 ▽ = 0	THIS DRAWING CONTAINS INFORMATION THAT IS PROPRIETARY TO MOLEX ELECTRONIC TECHNOLOGIES, LLC AND SHOULD NOT BE USED WITHOUT WRITTEN PERMISSION		CURRENT REV DESC:		  MX150 1X4 BLADE SEALED ASSEMBLY MAT SEAL  PRODUCT CUSTOMER DRAWING			
	DIMENSION UNITS	SCALE	EC NO: 607930					
	mm	1:1	DRWN: HKLIANG 2018/11/09					
	GENERAL TOLERANCES (UNLESS SPECIFIED)		CHK'D: JDENG02 2018/12/04					
	ANGULAR TOL ± 3.0°		APPR: JDENG02 2018/12/04					
	4 PLACES ±		INITIAL REVISION:					
	3 PLACES ±		DRWN: DGRIFITHS 2005/08/26					
	2 PLACES ± 0.1		APPR: smarceau 2005/08/29					
	1 PLACE ± 0.3		DOCUMENT NUMBER					
	0 PLACES ±		SD-33481-041					
DRAFT WHERE APPLICABLE MUST REMAIN WITHIN DIMENSIONS		THIRD ANGLE PROJECTION	DRAWING	SERIES	DOCUMENT NUMBER	DOC TYPE	DOC PART	REVISION
			D-SIZE	33481	PSD	001	W2	
		MATERIAL NUMBER		CUSTOMER	SHEET NUMBER			
		GENERAL MARKET		5 OF 5				