

FEATURES

1. Wide 2:1 input voltage range
2. High efficiency up to 88%
3. No-load power consumption as low as 0.12W
4. I/O test isolation voltage 1.5k VDC
5. Input under-voltage protection, output short-circuit, over-current, over-voltage protection
6. Operating ambient temperature range:-40°C to+85°C
7. Meet CISPR32/EN55032 CLASS A, without extra components
8. Industry standard pin-out
9. Meets IEC60950,EN62368 standard



3 years
Warranty

Selection Guide

Part No.	Input Voltage (VDC)		Output		Full Load Efficiency(%) Min./Typ.	Capacitive Load (μF) Max.
	Nominal (Range)	Max.	Voltage (VDC)	Current (mA) Max./Min.		
MFA1205YMD-6WR3	12 (9-18)	20	±5	±600/0	79/81	470
MFA1212YMD-6WR3			±12	±250/0	83/85	100
MFA1215YMD-6WR3			±15	±200/0	81/83	100
MFB1205YMD-6WR3			5	1200/0	79/81	1000
MFB1212YMD-6WR3			12	500/0	83/85	470
MFA2405YMD-6WR3	24 (18-36)	40	±5	±600/0	81/83	470
MFA2412YMD-6WR3			±12	±250/0	85/87	100
MFA2415YMD-6WR3			±15	±200/0	85/87	100
MFB2403YMD-6WR3			3.3	1500/0	75/77	1800
MFB2405YMD-6WR3			5	1200/0	80/82	1000
MFB2409YMD-6WR3			9	667/0	83/85	470
MFB2412YMD-6WR3			12	500/0	83/85	470
MFB2415YMD-6WR3			15	400/0	84/86	220
MFB2424YMD-6WR3			24	250/0	83/85	100
MFB4803YMD-6WR3	48 (36-75)	80	3.3	1500/0	77/79	1800
MFB4805YMD-6WR3			5	1200/0	81/83	1000
MFB4812YMD-6WR3			12	500/0	85/87	470
MFB4815YMD-6WR3			15	400/0	86/88	220
MFB4824YMD-6WR3			24	250/0	86/88	100

Input Specifications

Item	Operating Conditions	Min.	Typ.	Max.	Unit	
Input Current (full load / no-load)	12VDC nominal input series, nominal input voltage	--	617/10	633/22	mA	
	24VDC nominal input series, nominal input voltage	3.3VDC output	--	268/5		275/15
		Others	--	305/5		313/15
	48VDC nominal input series, nominal input voltage	3.3VDC output	--	130/4		134/8
Others		--	150/4	155/8		
Reflected Ripple Current		--	20	--	mA	
Surge Voltage (1sec. max.)	12VDC nominal input series	-0.7	--	25	VDC	
	24VDC nominal input series	-0.7	--	50		
	48VDC nominal input series	-0.7	--	100		
Start-up Voltage	12VDC nominal input series	--	--	9	VDC	
	24VDC nominal input series	--	--	18		

Input Under-voltage Protection	48VDC nominal input series	--	--	36
	12VDC nominal input series	5.5	6.5	--
	24VDC nominal input series	12	15.5	--
	48VDC nominal input series	26	30	--
Input Filter	Pi filter			
Hot Plug	Unavailable			

Output Specifications

Item	Operating Conditions	Min.	Typ.	Max.	Unit	
Voltage Accuracy	5%-100% load	--	±1	±3	%	
	0%-5% load	±5VDC output	--	±2		±5
		others	--	±1		±3
Linear Regulation	Input voltage variation from low to high at full load	Vo1	--	±0.2	±0.5	
		Vo2	--	±0.5	±1	
Load Regulation ^①	5%-100% load	Vo1	--	±0.5	±1	
		Vo2	--	±0.5	±1.5	
Cross Regulation	Vo1 load at 50%, Vo2 load at range of 10%-100%	--	--	±5		
Transient Recovery Time		--	300	500	µs	
Transient Response Deviation	25% load step change	3.3VDC, 5VDC, ±5VDC output	--	±5	±8	%
		Others	--	±3	±5	
Temperature Coefficient	Full load	--	--	±0.03	%/°C	
Ripple & Noise ^②	20MHz bandwidth, 5%-100% load	--	60	85	mV p-p	
Over-voltage Protection	Input voltage range	110	--	160	%Vo	
Over-current Protection		110	140	190	%Io	
Short-circuit Protection		Continuous, self-recovery				
Note: ① Load regulation for 0%-100% load is ±5%; ② ripple & noise at ≤5% load is 5%Vo Max. The "parallel cable" method is used for ripple and noise test, please refer to DC-DC Converter Application Notes for specific information.						

General Specifications

Item	Operating Conditions	Min.	Typ.	Max.	Unit
Isolation	Input-output Electric Strength Test for 1 minute with a leakage current of 1mA max.	1500	--	--	VDC
Insulation Resistance	Input-output resistance at 500VDC	1000	--	--	MΩ
Isolation Capacitance	Input-output capacitance at 100KHz/0.1V	--	1000	--	pF
Operating Temperature	See Fig. 1	-40	--	+85	°C
Storage Humidity	Non-condensing	5	--	95	%RH
Storage Temperature		-55	--	+125	°C
Pin Soldering Resistance Temperature	Soldering spot is 1.5mm away from case for 10 seconds	--	--	+300	
Vibration		10-55Hz, 2G, 30 Min. along X, Y and Z			
Switching Frequency *	PWM mode	--	300	--	KHz
MTBF	MIL-HDBK-217F@25°C	1000	--	--	K hours
Note: *Switching frequency is measured at full load. The module reduces the switching frequency for light load (below 50%) efficiency improvement.					

Mechanical Specifications

Case Material	Aluminum alloy
Dimensions	25.40 × 25.40 × 11.70 mm
Weight	12.5g(Typ.)

Cooling Method	Free air convection
-----------------------	---------------------

EMC Specifications

EMI	CE	12VDC, 24VDC nominal input series	CISPR32/EN55032	CLASS A (without extra components)/ CLASS B (see Fig.3-② for recommended circuit)	
		48VDC nominal input series	CISPR32/EN55032	CLASS B (see Fig.3-② for recommended circuit)	
	RE	12VDC, 24VDC nominal input series	CISPR32/EN55032	CLASS A (without extra components)/ CLASS B (see Fig.3-② for recommended circuit)	
		48VDC nominal input series	CISPR32/EN55032	CLASS B (see Fig.3-② for recommended circuit)	
EMS	ESD		IEC/EN61000-4-2	Contact ±4KV	perf. Criteria B
	RS		IEC/EN61000-4-3	10V/m	perf. Criteria A
	EFT		IEC/EN61000-4-4	±2KV (see Fig.3-① for recommended circuit)	perf. Criteria B
	Surge		IEC/EN61000-4-5	line to line ±2KV (see Fig.3-① for recommended circuit)	perf. Criteria B
	CS		IEC/EN61000-4-6	3 Vr.m.s	perf. Criteria A
	Voltage dips, short interruptions and voltage variations immunity		IEC/EN61000-4-29	0%, 70%	perf. Criteria B

Typical Characteristic Curves

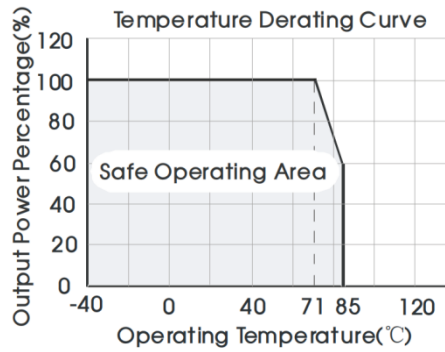
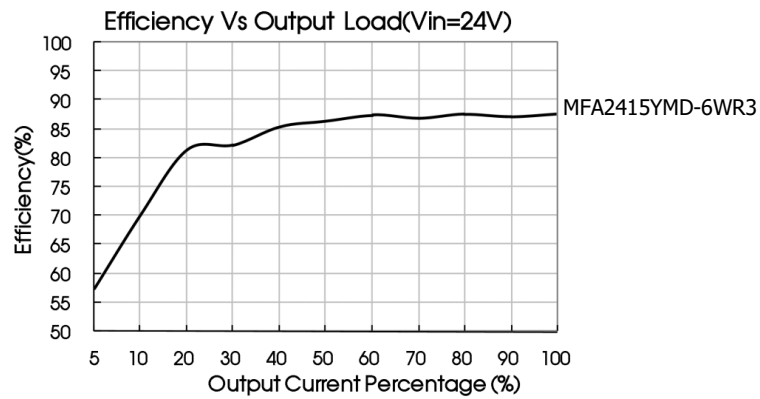
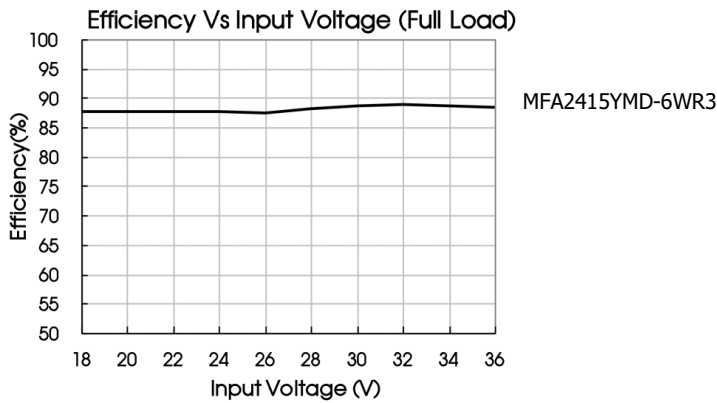
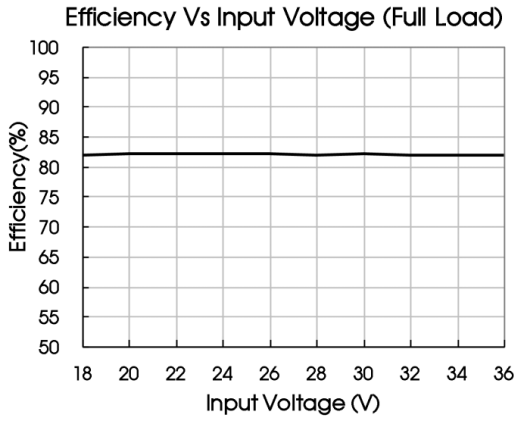
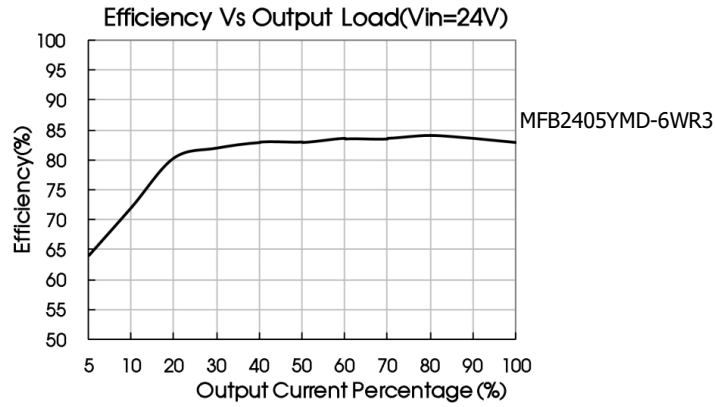

Fig. 1





MFB2405YMD-6WR3



MFB2405YMD-6WR3

Typical Circuit Design And Application

1. Typical application

All the DC/DC converters of this series are tested before delivery using the recommended circuit shown in Fig. 2.

Input and/or output ripple can be further reduced by appropriately increasing the input & output capacitor values C_{in} and C_{out} and/or by selecting capacitors with a low ESR (equivalent series resistance). Also make sure that the capacitance is not exceeding the specified max. capacitive load value of the product.

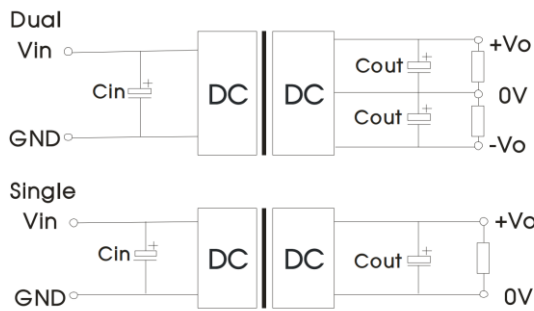

Fig. 2

Vin(VDC)	Cin(μF)	Cout(μF)
12	100μF/25V	Vo(3/±3/5/±5/9/±9):10μF/16V Vo(12/±12/15/±15V):10μF/25V
24	10 - 47μF/50V	Vo(24/±24V):10μF/50V
48	100μF/100V	

2. EMC compliance circuit

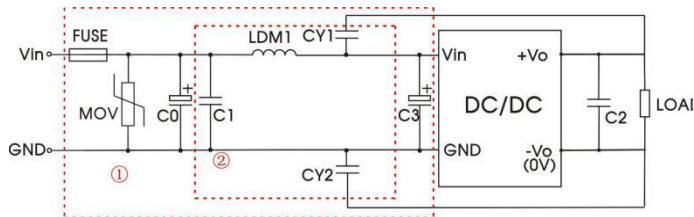

Fig. 3

Notes: For EMC tests we use Part ① in Fig. 3 for immunity and part ② for emissions test. Selecting based on needs.

Parameter description

Model	Vin:12V	Vin:24V	Vin:48V
FUSE	Choose according to actual input current		
MOV	S14K20	S20K30	14D101K
C0	1000μF/35V	1000μF/50V	330uF/100V
C1	1μF/50V		4.7uF/100V
C2	Refer to the Cout in Fig.2		
C3	330μF/35V	330μF/50V	330μF/100V
LDM1	4.7μH		
CY1/CY2	1nF/2KV		

3. The products do not support parallel connection of their output

Dimensions and Recommended Layout

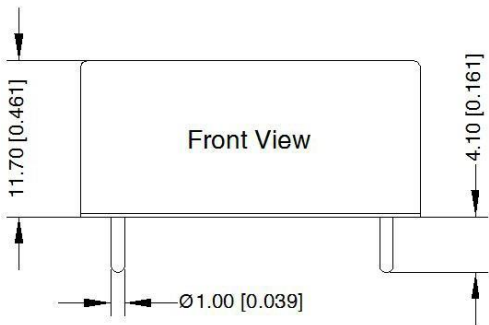

THIRD ANGLE PROJECTION

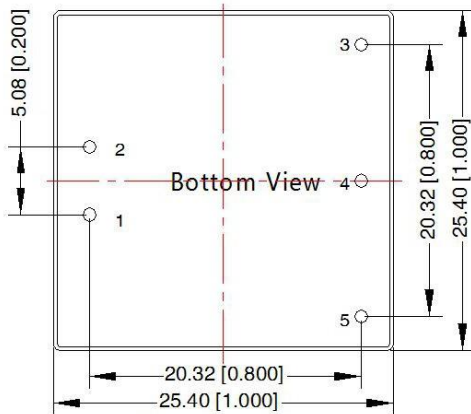
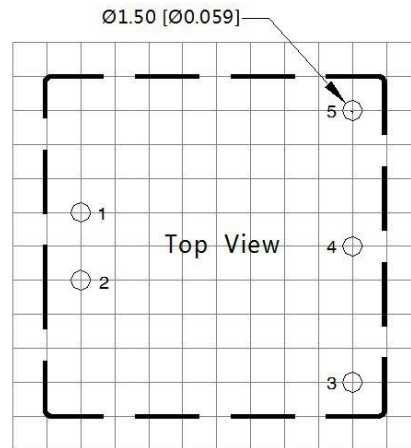

Note: Grid 2.54*2.54mm

Pin-Out		
Pin	Single	Dual
1	GND	GND
2	Vin	Vin
3	+Vo	+Vo
4	No Pin	0V
5	0V	-Vo

Note:
 Unit: mm[inch]
 Pin diameter tolerances: ± 0.10 [± 0.004]
 General tolerances: ± 0.50 [± 0.020]

Note:

1. If the product works under the minimum required load, it cannot guarantee that the performance of the product complies with all the performance indicators in this manual;
2. The maximum capacitive load is tested under the input voltage range and full load condition;
3. Unless otherwise stated, all indexes in this manual are measured at $T_a=25^\circ\text{C}$, humidity $<75\%RH$, nominal input voltage and rated output load;
4. All index testing methods in this manual are based on the enterprise standards of the company;
5. Our company can provide product customization, specific needs can directly contact our technical staff;