

CONTENTS

1. SUMMARY	1
1.1 General Description.....	1
1.2 Features.....	1
2. GENERAL SPECIFICATIONS	2
3. INPUT / OUTPUT TERMINALS	3
3.1 CN1 Pin assignment (LCD Interface).....	3
4. ABSOLUTE MAXIMUM RATINGS	4
5. ELECTRICAL CHARACTERISTICS	5
5.1 DC Characteristics for Panel Driving.....	5
5.2 DC Characteristics for Backlight Driving.....	5
5.3 Recommended Power ON/OFF Sequence.....	6
5.4 LCD Module Block Diagram.....	8
6. TIMING CHARACTERISTICS	9
6.1 DP Characteristics	9
6.2 EDID	11
7. OPTICAL CHARACTERISTICS	12
8. RELIABILITY TEST	15
9. MECHANICAL DRAWING	16
10. PACKING INSTRUCTION	17
11. PRECAUTIONS FOR USE OF LCD MODULES	20
11.1 Handling Precautions.....	20
11.2 Storage precautions.....	20
11.3 Transportation Precautions	20
11.4 Screen saver Precautions.....	20
11.5 Safety Precautions	20

1. Summary

1.1 General Description

This is a 15.6 inch a-Si TFT-LCD module with Normal-Black technology. It is composed of a TFT-LCD panel, a driver circuit, PCB, and a LED backlight unit.

1.2 Features

- Ultra-wide viewing angle
- High resolution
- Interface: eDP 1.2
- LED driver integrated
- This product will comply with UL62368-1/CSA C22.2 No.62368-1-03
- This product will comply with the European RoHS Directive (2011/65/EU) and Delegated Directive (2015/863/EU, Amending Annex II of 2011/65/EU)

2. General Specifications

	Feature	Spec	Unit
Display Spec	Size	15.6 inches	-
	Resolution	1920(RGB)x1080	-
	Pixel Pitch	0.17925x0.17925	mm
	TFT Active Area	344.16*193.59	mm
	Technology Type	a-Si	-
	Pixel Configuration	R.G.B Vertical Stripe	-
	Display Mode	SFT, Normally Black	-
	Surface Treatment	Hard coating (3H)	-
	Viewing Direction	All	-
	Gray Scale Inversion Direction	No Gray Scale Inversion	-
Mechanical Characteristics	LCM (W x H x D)	351.84x 208.38 x 6.0	mm
	Weight	570	g
Optical Characteristics	Luminance	500	cd/m ²
	Contrast Ratio	1500:1	-
	NTSC	72 TYP	%
	Viewing Angle	89/89/89/89(SFT)	degree
Electrical Characteristics	Interface	eDP1.2	-
	Color Depth	16.7 Million	color
	Power Consumption	LCD:730 Backlight: 9840 LCM: 10570(all white pattern), 6150 max, at 200nits white pattern	mW

Table 2.1 General TFT Specifications

3. Input / Output Terminals

3.1 CN1 Pin assignment (LCD Interface)

Connector Information	
LCD Module connector	IPEX 20455-040E-76
Matching connector	IPEX 20453-040T-03

Table 3.1.1 Connector information

No	Symbol	I/O	Description	Comment
1	NC(SCL)	N	No connection. TIANMA Internally use	
2	NC(SDA)	N	No connection TIANMA Internally use	
3	NC(GND)	N	No connection TIANMA Internally use	
4	NC	N	No connection	
5	NC	N	No connection	
6	VDD	P	USB power	For TP, Non use can NC
7	VDD	P	USB power	For TP, Non use can NC
8	VSS	P	USB Ground	
9	D+	I	USB D+	
10	D-	I	USB D-	
11	NC	N	No connection	
12	LED_VCCS	P	BL_POWER	
13	LED_VCCS	P	BL_POWER	
14	LED_VCCS	P	BL_POWER	
15	LED_VCCS	P	BL_POWER	
16	NC	N	No connection	
17	NC	N	No connection	
18	LED_PWM	I	BL_PWM signal input	
19	LED_En	I	BL ENABLE	
20	BL_GND	P	BL Ground	
21	BL_GND	P	BL Ground	
22	BL_GND	P	BL Ground	
23	BL_GND	P	BL Ground	
24	HPD	O	HPD signal pin	
25	GND	P	Ground	
26	GND	P	Ground	
27	NC	N	No connection	
28	VCCS	P	Power Supply +3.3 V (typical)	
29	VCCS	P	Power Supply +3.3 V (typical)	
30	GND	P	Ground	
31	AUX-	I	Complement Signal-Auxiliary Channel	

32	AUX+	I	True Signal-Auxiliary Channel	
33	GND	P	Ground	
34	ML0+	I	True Signal-Main Lane 0	
35	ML0-	I	Complement Signal-Lane 0	
36	GND	P	Ground	
37	ML1+	I	True Signal-Main Lane 1	
38	ML1-	I	Complement Signal-Lane 1	
39	GND	P	Ground	
40	NC	N	No connection	

Table 3.1.2 Pin Assignment for LCD Interface

Note1: I/O definition: I---Input, O---Output, P---Power/Ground, N---No connection

Note2: All of the GND pins should be connected to the system ground.

Table 3.2.1 Connector information

4. Absolute Maximum Ratings

Item	Symbol	MIN	MAX	Unit	Remark
Power Voltage	VCCS	0.3	5	V	
BL_POWER Input	LED_VCCS	-0.3	27	V	
BL_PWM signal input	LED_PWM	-0.3	27	V	
BL_ENABLE	LED_EN	-0.3	27	V	
Operating Temperature	Top	-10	70	°C	
Storage Temperature	Tst	-20	70	°C	
Relative Humidity Note2	RH	--	≤95	%	Ta≤40°C
		--	≤85	%	40°C < Ta≤50°C
		--	≤55	%	50°C < Ta≤60°C
Absolute Humidity	AH	--	≤70	g/m ³	Ta > 60°C

Table 4.1 Absolute Maximum Ratings

Note1: Ta means the ambient temperature. It is necessary to limit the relative humidity to the specified temperature range. Condensation on the module is not allowed.

Note2: The absolute maximum rating values of this product are not allowed to be exceeded at any times. A module should be used with any of the absolute maximum ratings exceeded, the characteristics of the module may not be recovered, or in an extreme condition, the module may be permanently destroyed

5. Electrical Characteristics

5.1 DC Characteristics for Panel Driving

Item	Symbol	MIN	TYP	MAX	Unit	Remark	
Supply Voltage	VCCS	3.0	3.3	3.6	V		
Hot plug Detect	HPD	2.4	2.5	2.6	V		
Power Consumption	60Hz	P	--	730	--	mW	White pattern
Inrush	VCCS	--	--	1.5	A		

Table 5.1.1 Operating Voltages

NOTE1: Power consumption tested under white pattern @60Hz

5.2 DC Characteristics for Backlight Driving

Item	Symbol	Min	Typ	Max	Unit	Remark	
BL_POWER Input	LED_VCCS	10.8	12	13.2	V		
Power supply current	I_{BL_PWR}		820		mA		
Input voltage for LED_PWM signal	High	VDFH1	1.6		5	V	
	Low	VDFL1	0		0.8	V	
Input voltage for LED_EN signal	High	VDFH2	1.6		5	V	
	Low	VDFL2	0		0.8	V	
PWM frequency	f_{PWM}	190		20K	Hz	NOTE1	
PWM duty ratio	DR_{PWM}	10		100	%		
Power Consumption	W_{BL}		9.84		W		
LED Life time	--	50000			hrs	NOTE3	

Table 5.2.1 LED Backlight Characteristics

Note1: Optical performance should be evaluated at $T_a=25^{\circ}\text{C}$ only.

Note2: If LED is driven by high current, high ambient temperature & humidity condition, The life time of LED will be reduced.

Note3: Operating life means brightness goes down to 50% of initial brightness. Typical operating life time is estimated data.

5.3 Recommended Power ON/OFF Sequence

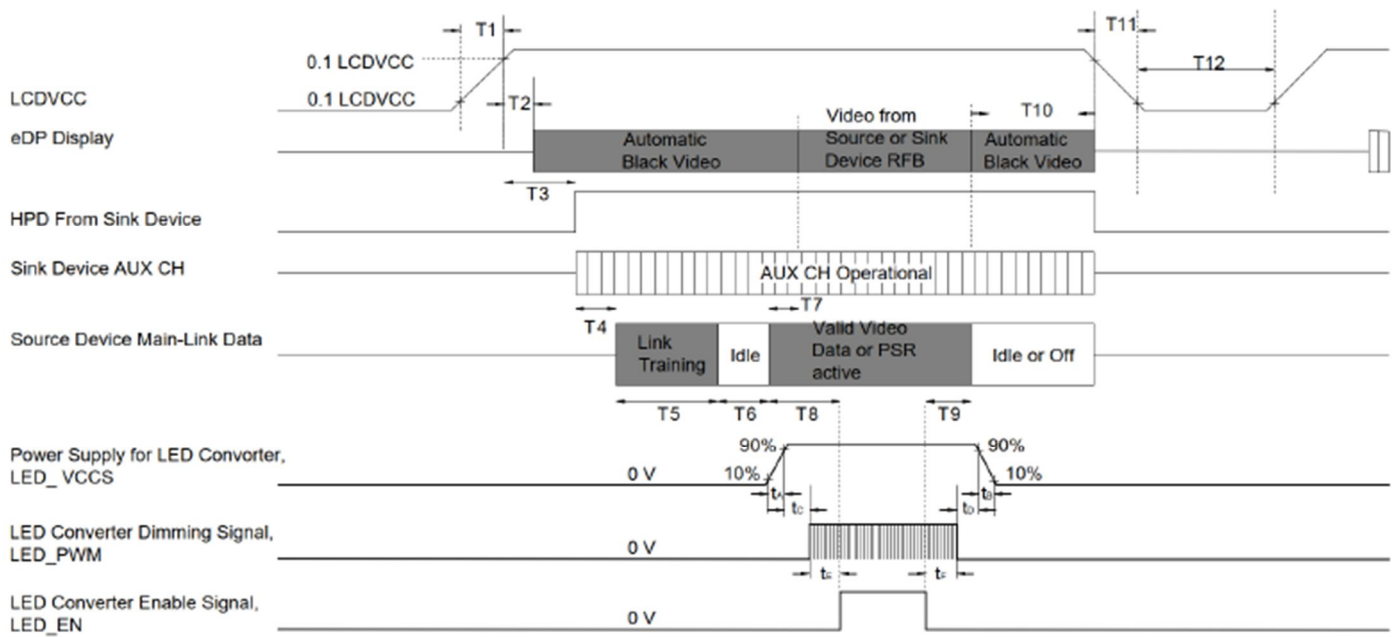

Timing Parameter	Timing Parameter	Required By	Value		Units	Notes
			Min.	Max.		
T1	Power rail rise time, 10% to 90%	Source	0.5	10	ms	N/A
T2	Delay from LCDVCC to automatic Black Video generation	Sink	0	200	ms	Automatic Black Video generation prevents display noise until valid video data is received from the Source (see Notes: 1 and 2 below)
T3	Delay from LCDVCC to HPD high	Sink	0	200	ms	Sink AUX Channel must be operational upon HPD high (see Note: 3 below)
T4	Delay from HPD high to link training initialization	Source	-	-	ms	Allows for Source to read Link capability and initialize
T5	Link training duration	Source	-	-	ms	Dependant on Source link training protocol
T6	Link idle	Source	-	-	ms	Min accounts for required BS-Idle pattern. Max allows for Source frame synchronization.
T7	Delay from valid video data from Source to video on display	Sink	0	50	ms	Max value allows for Sink to validate video data and timing. At the end of T7, Sink will indicate the detection of valid video data by setting the SINK_STATUS bit to logic 1 (DPCD 00205h, bit 0), and Sink will no longer generate automatic Black Video.

T8	Delay from valid video data from Source to backlight enable	Source	-	-	ms	Source must assure display video is stable
T9	Delay from backlight disable to end of valid video data	Source	-	-	ms	Source must assure backlight is no longer illuminated. At the end of T9, Sink will indicate the detection of no valid video data by setting the SINK_STATUS bit to logic 0 (DPCD 00205h, bit 0), and Sink will automatically display Black Video. (See Notes: 1 and 2 below)
T10	Delay from end of valid video data from Source to power off	Source	0	500	ms	N/A
T11	Power rail fall time, 90% to 10%	Source	-	200	ms	N/A
T12	Power off time	Source	500	-	ms	N/A
tA			0.5	50	ms	
tB			0.5	200	ms	
tC			1		ms	
tD			1	-	ms	
tE			10		ms	
tF			10	-	ms	

Note 1: The sink must include the ability to generate black video autonomously. The sink must automatically enable black video under the following conditions:
 -upon LCDVDD power on (with in T2 max)-when the "Novideostream_Flag" (VB-ID Bit 3) is received from the source (at the end of T9).
 -when no main link data, or invalid video data, is received from the source. Black video must be displayed within 64ms (typ) from the start of either condition. Video data can be deemed invalid based on MSA and timing information, for example.

Note 2: The sink may implement the ability to disable the black video function, as described in Note 1, above, for system development and debugging purpose.

Note 3: The sink must support AUX_CH polling by the source immediately following LCDVDD power on without causing damage to the sink device (the source can re-try if the sink is not ready). The sink must be able to respond to an AUX_CH transaction with the time specified within T3 max..

5.4 LCD Module Block Diagram

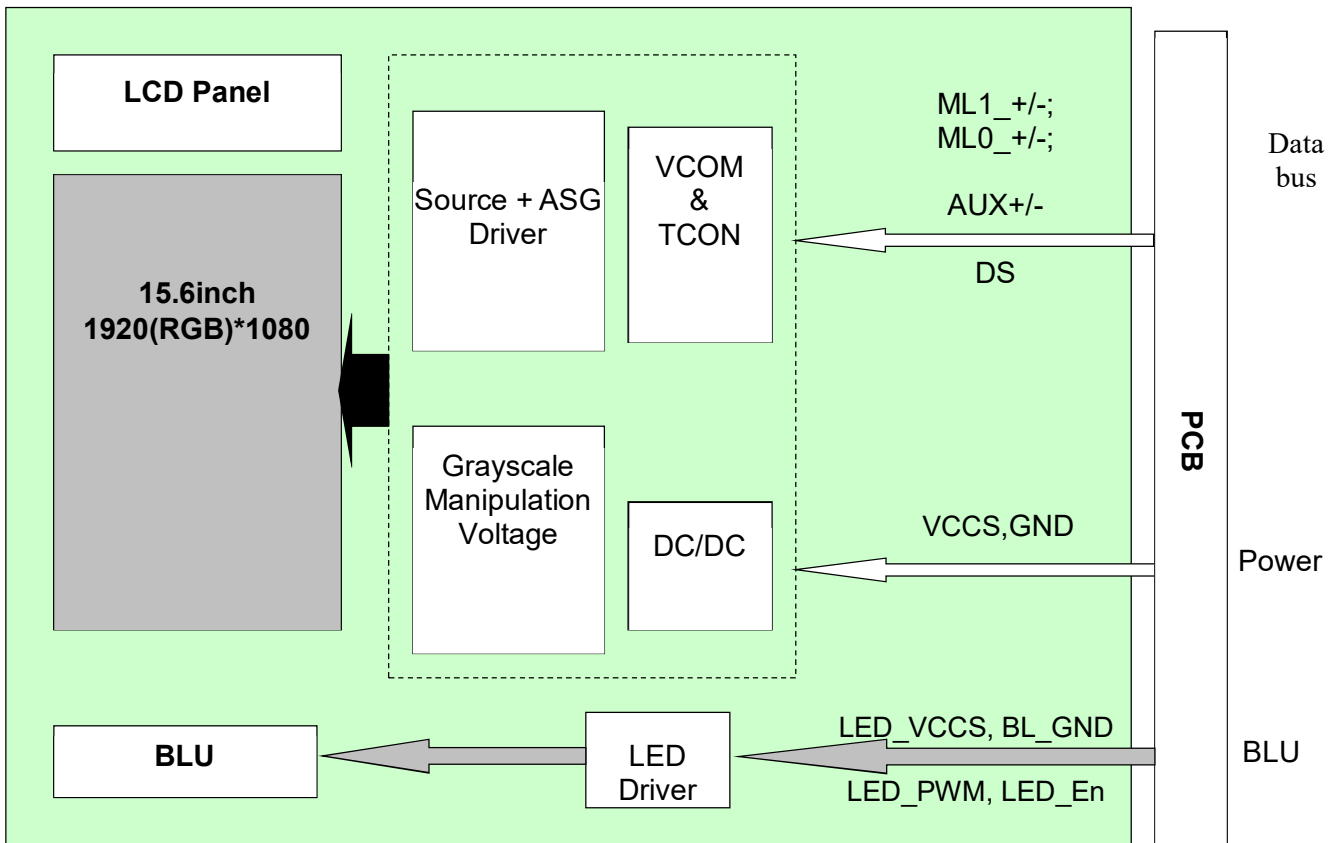

Figure 5.4.1 LCD Module Block Diagram

6. Timing Characteristics

6.1 DP Characteristics

Aux Channel Characteristics

AUX

AC Specification	Min.	Typ.	Max.	Unit
Unit interval	0.4	-	0.6	Us
AUX differential peak to peak voltage at TX	0.18	-	0.8	V
AUX differential peak to peak voltage at RX	0.14	-	1.36	V
Rx sensitivity	0.1	-	-	V

Main Link Characteristics

Main-Link

DC Specification	Min	Typ	Max	Unit
DC common mode voltage	0		2	V
AC Specification	Min	Typ	Max	Unit
Frequency for high bit rate	2.68569	2.7	2.70081	Gbps
Frequency for reduced bit rate	1.611414	1.62	1.620486	Gbps
Spread spectrum clock (down spreading)	0		0.5	%
SSC modulation frequency	30		33	KHz
Differential peak-to-peak input voltage at package pins	100			mV
Differential termination resistance	80		120	ohm
Rx short circuit current limit			50	mA
Rx intra-pair skew tolerance at HBR			60	ps

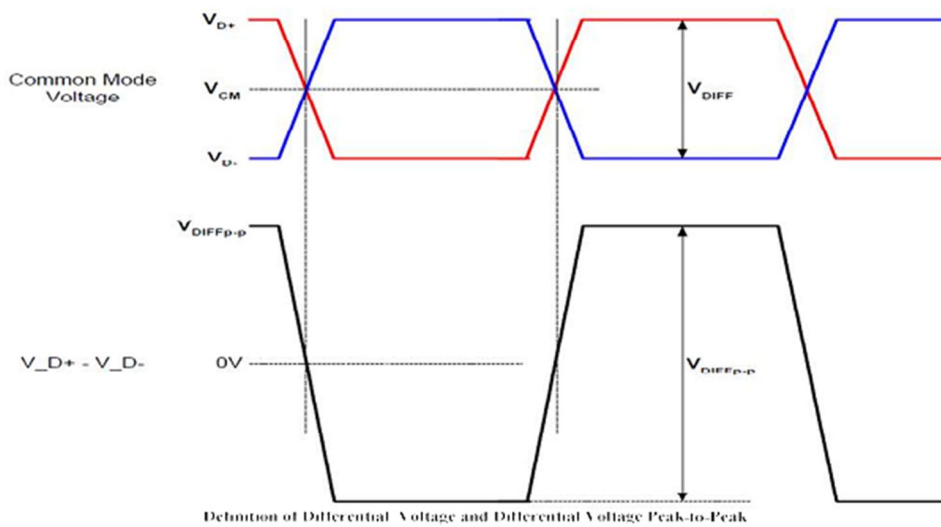

6.2 EDID

Timing Setting

ITEM		SYMBOL	MIN	TYP	MAX	UNIT		
LCD Timing	Frame Rate			60	75	Hz		
	DCLK	Frequency	f_{CLK}	142.9	148.5	158.7	MHz	
		Period	t_{CLK}	/			ns	
	DENA	Horizontal	Horizontal Total time	t_H	2150	2200	2300	DCLK
			Horizontal Active time	t_{HA}	1920			DCLK
			Horizontal Blank time	t_{HB}	230	280	380	DCLK
		Vertical	Vertical Total time	t_V	1108	1125	1150	Hline
			Vertical Active time	t_{VA}	1080			Hline
			Vertical Blank time	t_{VB}	28	45	70	Hline

7. Optical Characteristics

Item	Symbol	Condition	Min	Typ	Max	Unit	Remark
View Angles	θT	$CR \geq 10$	80	89		degree	Note2,3
	θB		80	89			
	θL		80	89			
	θR		80	89			
Contrast Ratio	CR	$\theta=0^\circ$	1000	1500			Note 3
Response Time	T_{ON}	25°C		25	35	ms	Note 4
	T_{OFF}						
Chromaticity	White	x	Backlight is on	0.278	0.308	0.338	Note 1,5
		y		0.295	0.325	0.355	
	Red	x		0.619	0.649	0.679	Note 1,5
		y		0.303	0.333	0.363	
	Green	x		0.268	0.298	0.328	Note 1,5
		y		0.601	0.631	0.661	
	Blue	x		0.123	0.153	0.183	Note 1,5
		y		0.018	0.048	0.078	
Uniformity	U		75	80		%	Note 6
NTSC	-			72		%	Note 5
Luminance	L		400	500		cd/m ²	Note 7

Table 7.1 Optical Parameters

Test Conditions:

1. The ambient temperature is 25°C.
2. The test systems refer to Note1 and Note2.

Note1: Definition of optical measurement system.

The optical characteristics should be measured in dark room. The optical characteristics are measured at the center point of the LCD screen.

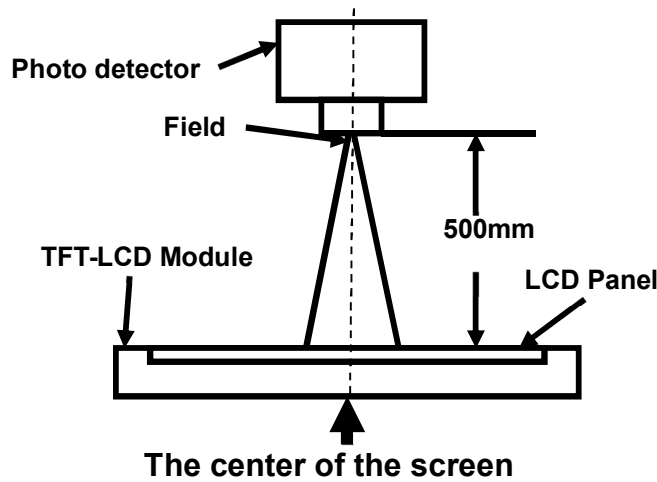

Fig1. Measurement Set Up

Note2: Definition of viewing angle range and measurement system. Viewing angle is measured at the center point of the LCD .

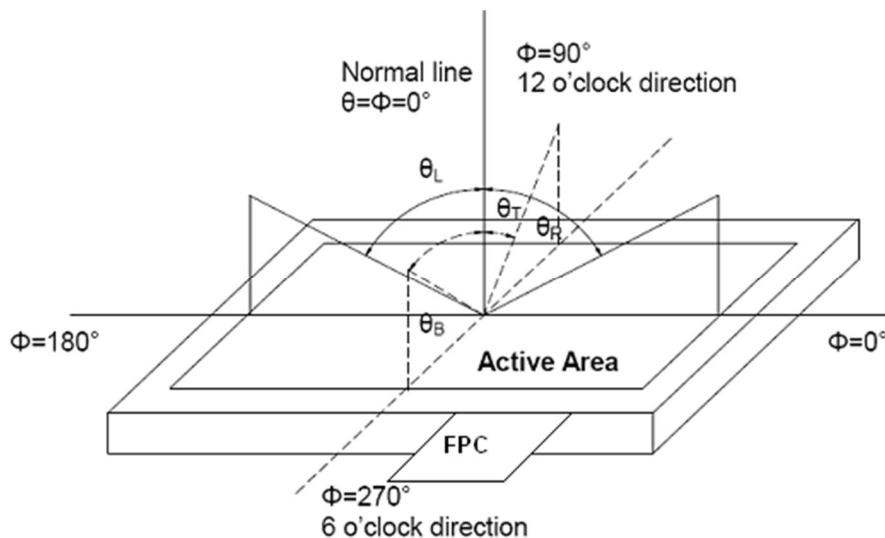

Fig2. Measurement viewing angle

Note3: Definition of contrast ratio

$$\text{Contrast ratio (CR)} = \frac{\text{Luminance measured when LCD is on the "White" state}}{\text{Luminance measured when LCD is on the "Black" state}}$$

Note4: Definition of Response time

For SFT LCM, the response time is defined as the LCD optical switching time interval between “White” state and “Black” state. Rise time (T_r) is the time between photo detector output intensity changed from 10% to 90%. And fall time (T_f) is the time between photo detector output intensity changed from 90% to 10%.

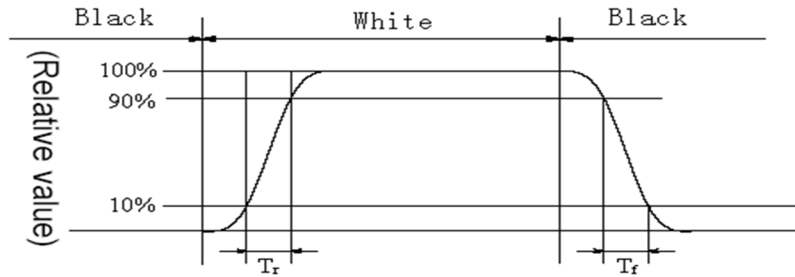

Fig4. Response Time Testing(SFT)

Note5: Definition of color chromaticity (CIE1931)

Color coordinates measured at center point of LCD.

Note6: Definition of Luminance Uniformity

Active area is divided into 9 measuring areas (Refer Fig.5). Every measuring point is placed at the center of each measuring area.

$$\text{Luminance Uniformity (U)} = \text{Lmin} / \text{Lmax}$$

Lmax: The measured Maximum luminance of all measurement position.

Lmin: The measured Minimum luminance of all measurement position.

L-----Active area length; W----- Active area width

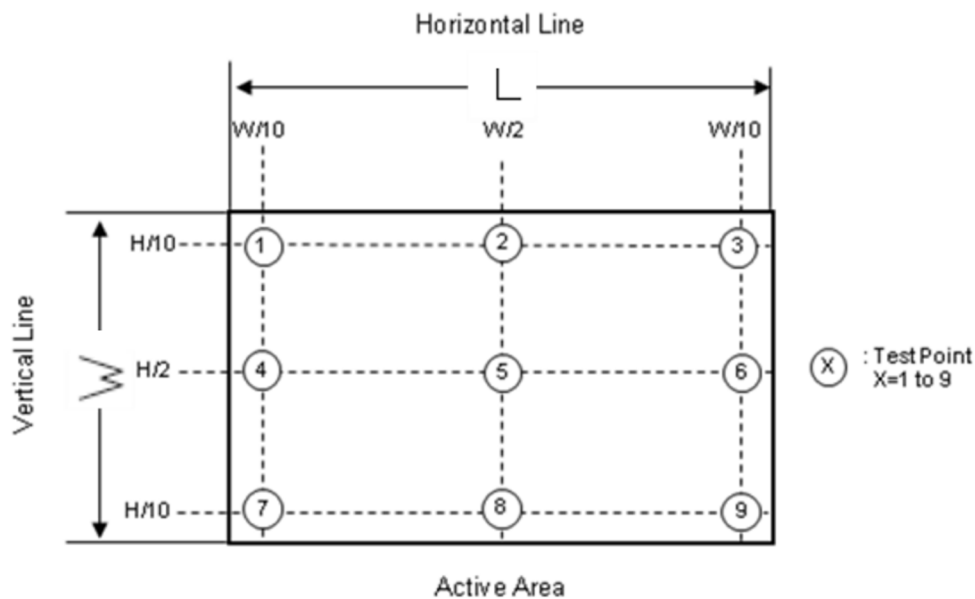

Fig5. Luminance Uniformity Measurement Locations(9 points)

Note7: Definition of Luminance:

Measure the luminance of white state at center point.

8. Reliability Test

No	Test Item	Condition	Remarks
1	High Temperature Operation	+70℃ , 240H	IEC60068-2-1:2007 GB2423.2-2008
2	Low Temperature Operation	-10℃ , 240H	IEC60068-2-1:2007 GB2423.1-2008
3	High Temperature Storage	+70℃ , 240H	IEC60068-2-1:2007 GB2423.2-2008
4	Low Temperature Storage	-20℃ , 240H	IEC60068-2-1:2007 GB2423.1-2008
5	Storage at High Temperature and Humidity(non-operation)	+50℃ , 80%RH , 240H	IEC60068-2-78 :2001 GB/T2423.3—2006
6	Thermal Shock (non-operation)	-20℃ , 30min~70℃ , 30min , change time : 5min , 100cycle	Start with cold temperature, End with high temperature, IEC60068-2-14:1984,GB2423.22-2002
7	ESD	C=150pF , R=330Ω , 9point/panel Air : ±8kv , 10times ; Contact : ±4kv , 10times ; (Environment : 15℃~35℃ , 30%~60% , 86Kpa~106Kpa)	IEC61000-4-2:2001 GB/T17626.2-2006
8	Vibration (Non-operation)	5 to 100Hz, 11.76m/s ² 1 minute/cycle X, Y, Z directions 50 times each direction	-
9	Shock (Non-operation)	294m/s ² , 11ms ±X, ±Y, ±Z directions 3 times each direction	-
10	Package Drop Test	Height: 80cm, 1 corner, 3edges, 6 surfaces	IEC60068-2-32:1990 GB/T2423.8—1995

Table 8.1 RA test condition

Note1: Temperature is the ambient temperature of sample

Note2: Before cosmetic and function test, the product must have enough recovery time, at least 2 hours at room temperature.

Note3: In the standard condition, there shall be no practical problem that may affect the display function. After the reliability test, the product's function only be guaranteed, but not for all of the cosmetic specification.

10. Packing Instruction

1. 包装材料规格表(Packaging Material) Per Carton

No	Item	Model (Material)	Dimensions(mm)	Unit Weight(Kg)	Quantity	Material Number
1	LCM module 模组	TM156VDGP12-00	351.8×208.38×4	0.570	14	TM156VDGP12-00
2	Tray 吸塑盘	PET	485×330×17.5	0.260	16	1150382820
3	Dust-proof Bag 防尘袋	PE	700×545×0.05	0.021	1	1680009800
4	Carton 纸箱	Corrugated Paper	544×365×250	1.01	1	1680007624
5	BOX 纸盒	Corrugated Paper	520×345×111	0.37	2	1680365000
6	Label 标签	Paper	100×52	0.001	1	1690000280
7	Total weight	13.912Kg				

2. 包装数量规格(Packaging Specification and Quantity)

(1) LCM quantity per tray: 1row×1column =1 每个tray装模组的数量: 1行×1列 =1
(2) Total LCM quantity in Carton: Number of PET trays 14× quantity per tray1= 14, and 2 empty tray 每箱装模组的数量: 装模组的tray数量14×每个tray装模组的数量1=14, 另外还有2个空tray
Note: Please refer to the data from “estimated report about the dimension and stack of Carton “ about stacking carton

包装过程示意

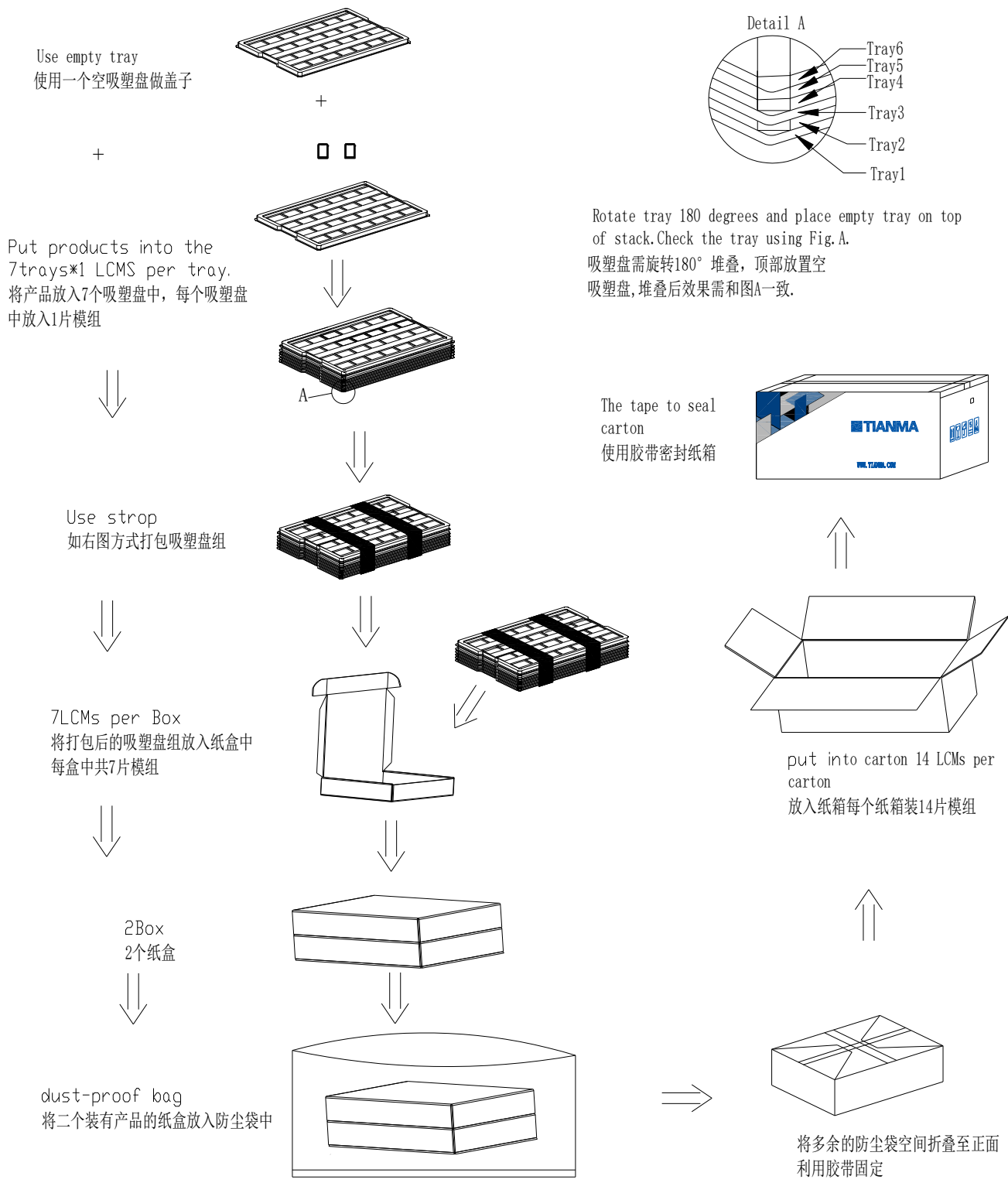

堆栈放置

纸箱堆叠数按2*3每层*共5层
 栈板尺寸：1100mm*1100mm
 栈板代码：PL004



11. Precautions for Use of LCD Modules

11.1 Handling Precautions

- (1) The display panel is made of glass. Do not subject it to mechanical shock by dropping it, etc.
- (2) If the display panel is damaged and the liquid crystal fluid inside it leaks out be sure not to get any in your mouth. If the fluid comes into contact with your skin or clothes promptly wash it off using soap and water.
- (3) Do not apply excessive force to the display surface or the bezel since this may cause the color tone to vary.
- (4) The polarizer covering the display surface of the LCD module is soft and easily scratched. Handle the polarizer carefully.
- (5) If the display surface is contaminated, breathe on the surface and gently wipe it with a soft dry cloth. If it is still not completely clear use a moist cloth with one of the following solvents:
 - Isopropyl alcohol
 - Ethyl alcoholSolvents other than those mentioned above may damage the polarizer. Specifically, do not use the following:
 - Water
 - Ketone
 - Aromatic solvents
- (6) Do not disassemble the LCD Module.
- (7) If powered off, do not apply the input signals.
- (8) To prevent destruction of the module by static electricity, be careful to maintain an optimum work environment.
- (9) Be sure to ground your body when handling the LCD Modules.
- (10) Tools used for assembly, must be properly grounded.
- (11) To reduce the amount of static electricity generated, do not conduct assembly or other work under very low humidity conditions.
- (12) The LCD Module is covered with a film to protect the display surface, remove film slowly under the ionizer.

11.2 Storage precautions

- (1) When storing the LCD modules avoid exposure to direct sunlight or to the light of fluorescent lamps.
- (2) The LCD modules should be stored within the rated storage temperature range. The recommend condition is: Temperature: 0 ~ 35 °C at normal humidity.
- (3) The LCD modules should be stored in a room without acid, alkali or other harmful gas.

11.3 Transportation Precautions

The LCD modules should not be dropped or subject to violent mechanical shock during transportation. Also they should avoid excessive pressure, water, high humidity and direct sunlight.

11.4 Screen saver Precautions

Not display the fixed pattern for a long time. Use a screen saver, if the fixed pattern is displayed on the screen

11.5 Safety Precautions

- (1) When you waste damaged or unnecessary LCDs, it is recommended to crush LCDs into pieces and wash them off with solvents such as acetone and ethanol, which should later be burned
- (2) Be sure to turn off the power supply when inserting or disconnecting the LED backlight cable.
- (3) LED driver should be designed to limit or stop its function when over current is detected on the LED.