

SECURITY CODE	B	MITSUBISHI ELECTRIC CORPORATION							
SPECIFICATION	PREPARED BY		R E V						
	CHECKED BY								
	APPROVED BY								
	DATE								

1. Type No. MIR8060B1-01
2. Application Non-contact thermal sensor
3. Structure Thermal diode infrared Sensor
Pixel size : 25um, Pixels(y,x) : 80x60
Frame rate : 4fps / 8fps
Silicon lens cap with AR coating
4 layers glass epoxy board
4. Outline Shown in Fig.13.1

This product complies with the RoHS * (2011/65/EU, (EU) 2015/863) Directive.

*Restriction of the Use of Certain Hazardous Substances in Electrical and Electronic Equipment

5. Absolute maximum ratings

Table 5.1

Parameter	Symbol	Min.	Max.	Unit
Supply voltage	VDD	-0.3	3.8	V
Digital Input/Output	MISO MOSI SCK NRST	-0.3	3.8	V
Storage Temperature	Tstg	-40	85	°C
Storage Humidity	Hstg		85	%RH
Operating Temperature	Top	-20	85	°C
Operating Humidity	Hop		85	%RH

<Note> Absolute maximum ratings are specified in JIS C 7032 and limit values that should never be exceeded, even momentarily, and that of any 2 parameters should never be reached at the same time. While circuit design, the attention must be required not to exceed absolute maximum ratings even by external factors.

6. Recommended operating conditions

Table 6.1 Recommended operating conditions

Parameter	Symbol	Min	Typ	Max	Unit
Operating voltage	VDD	3.0(TBD)	3.3	3.6	V
SPI communication frequency	SPI_SCK			2.1	MHz

7. Electrical characteristics (Test specification)

Table 7.1 Electrical characteristics

	Conditions	Min	Typ	Max	Unit	Remark
Output sensitivity	*1	27	30	33	Digit/K	-
Thermal resolution	-	-	-	TBD	mK	Optical center characteristics
Valid pixels ratio	*2	99.3	-	-	%	-
Angle of view (Vertical : Y)	-	74	78	-	Degree	-
Angle of view (Width : X)	-	TBD	53(TBD)	-	Degree	-
Current consumption	-	-	-	50	mA	During imaging
Detectable temperature range	-	-5	-	60	°C	

The test described in the electrical characteristics in Fig.7.1 are performed in an environment VDD=3.3V and 24±3°C. All tests are performed under the condition that sensitivity correction is ON and SPI communication clock is 1MHz.

Other test condition are as follows.

*1 An image of the subject at 40±0.5°C corresponding to 8×8 pixels near the center of the pixel array is taken and the sensitivity is measured. The sensitivity is corrected so as to be between 30±3digit/K.

No sensitivity is measured for a subject of a specified size around the pixel array.

*2 Valid pixels on the entire screen should be 99.3% or more. Two or more consecutive defective pixels are not accepted.

Definition of defective pixels: Defective pixels are pixels which displacement of output is 50% or less of maximum value under the following condition;

- Calibration has been performed in an environment of 24±3°C

- Capturing a subject at 40±0.5°C over the entire screen

Or pixels that do not meet the performance listed in Fig.7.1 other than the number of defects.

7.1 Calibration (activating the shutter) for capturing the thermal image

Calibration can be done with the shutter plate covering the optical lens to make the entering infrared light uniformly. Calibration operation will be finished in around 4.5 sec after enabling shutter by SPI (shutter enabling bit is set to ON).

As shown in Fig.7.1, the shutter plater should be placed in front of the optical lens and it should cover all angle of FOV of the optical lens.

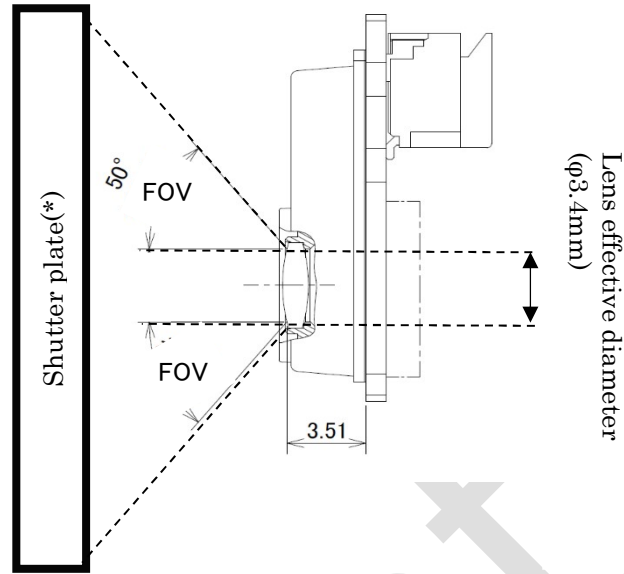

Fig.7.1 Shutter plate and sensor position

(*)Shutter plate should be larger than a quadrangle with viewing angles in the X and Y directions of 100°

8. Barcode format

Product type and product serial are described in the position shown in Fig.8.1.
 The character string to be printed is as follows. The same information converted into a two dimensional bar code is printed above character string.

- 8060B1 : Product type 6-digit(fixed)
- ZZ9999 : Serial number 6-digit
 - 1st~2nd-digit : Alphanumeric
 (0~9, A~Z [Prohibited characters=I, O, Q, S, V] 31Base number)
 - 3rd~6th-digit : 4-digit number
 From 000000~To ZZ9999

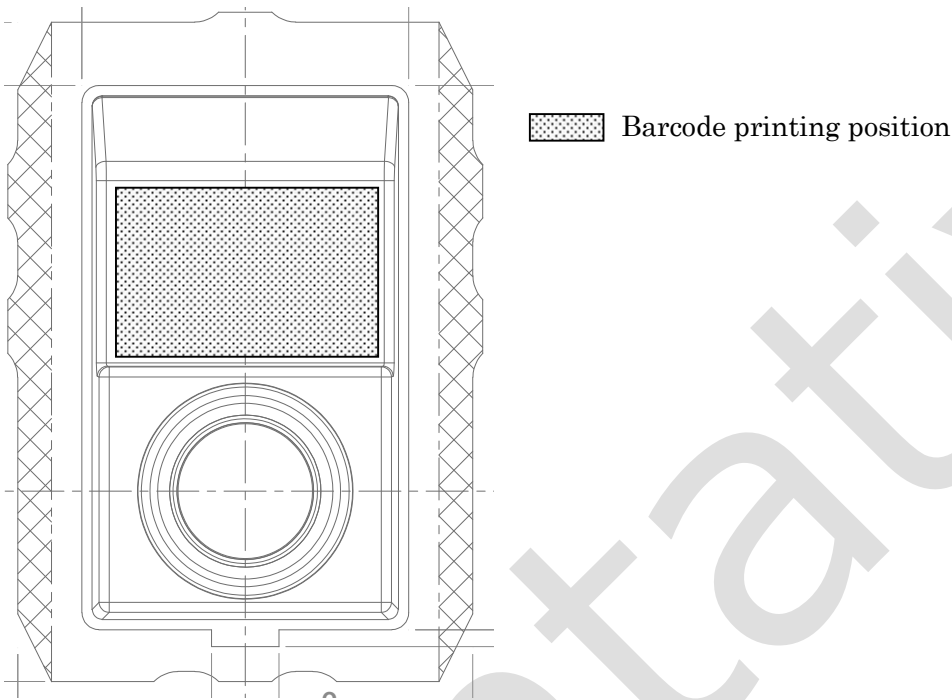

Fig.8.1 Barcode printing position

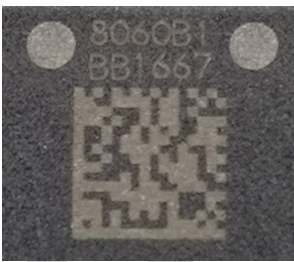

Fig.8.2 Sample of barcode printing

9. Certification Test

Table 9.1 Surroundings test*2

The output sensitivity change must be within $\pm 20\%$ for the following items.

PARAMETER	CONDITION	SAMPLE	RESULT
Vibration	10~55~10Hz, Amplitude1.5mm, XYZ direction 2hours each	5	Pass
Natural fall	Drop from 1m height to concrete floor in packed state 5 times	5	Pass
Connector pull	Lead wire batch 19.6N for 5sec	5	Pass
Connector push	Horizontal at 45°19.6N for 5sec	3	Pass
ESD Endurance	HBM method(C=100pF,R=1.5k Ω) ± 1 kV	6	Pass

Table 9.2 Lifespan test*2

The output sensitivity change must be within $\pm 20\%$ for the following items.

PARAMETER	CONDITION	SAMPLE	RESULT
High temperature Operating	85°C, 1000hrs, 3.6V	11	Pass
Low temperature Operating	-20°C, 1000hrs, 3.6V	11	Pass
Temperature cycle	-40~80°C, 30min, 200cycle	11	Pass
High humidity High temperature Operating	85°C, 85%RH, 1000hrs, 3.6V	11	Pass
High humidity High temperature Storage	85°C, 85%RH, 1000hrs	11	Pass

*2 MIR8060B1-01 passed the “9. Certification Test” in the development phase. The design is applied to mass production.

10. Serial interface

10.1 Interface

This product is equipped with SPI as an interface to communicate with external devices, and realizes the image data reading function. The SPI operates in single-master /single-slave mode in which the MCU is the master and this IC is the slave. Communication is performed by driving three lines of SCK(Clock)/MOSI(Master-Out Slave-In)/MISO(Master-In Slave-Out). Signals are transmitted and received at a CMOS level (3.3V).

Table 10.1 Summary of data length

Parameter	
Clock	≤ 2.1MHz
Word length	8-bit
Pixel length	2word
Cluster length*	8word(=4pixel)

*The cluster length is the minimum number of words that must be read in one continuous communication (Refer to section 10.4)

Connection example

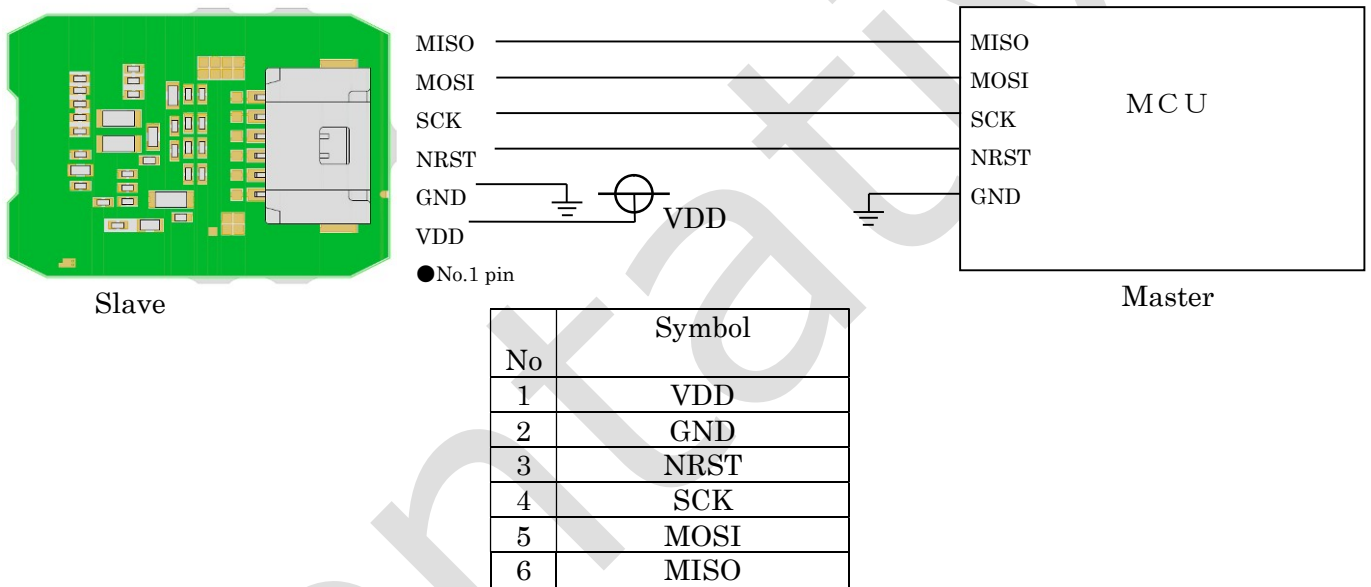

Fig.10.1 Pin assign and connection

10.2 Basic communication format

The communication of SPI is performed in units of a sequence (written as “frame” in RSPI). The length of a sequence is 8 words, the length of a word is 8 bits(MSB first) and the communication speed is 2.1MHz at the maximum. It supports full-duplex communication that mean input data from MCU to this IC by MOSI(write) and output specified data from this IC to MCU by MISO(read). This function make realize verification of setting data (Read-Back) and acquisition of image data. Note that data transmitted and received through MISO and MOSI move at the rising edge (odd edge) of SCK and are captured at the falling edge (even edge).(The state when the SCK is idle is low.)

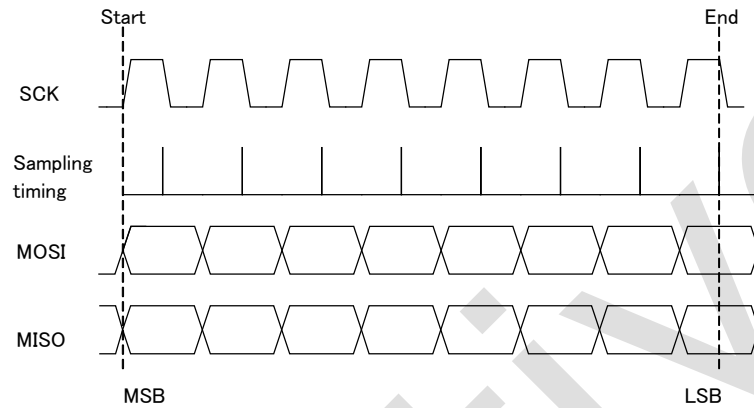

Fig.10.2 Basic communication format

10.3 User register number

The module information shown in Fig.10.4 can be obtained by accessing the sensor information register. (Addr: 0x75)

Table 10.4 Description of sensor information register

Register name	Register description
ID[7:0]	Lot ID:ID of MIR8060B1-01 is fixed as '00000100'.
SN[23:0]	Serial number. The upper two digits (00 to ZZ) of the six digits of the serial number described in item number 8 “barcode format” are three-digit decimal number (0 to 961) and indicated by unsigned integer [10:0].
SEL_VDD	3.3V or 5V Power selection and charge pump (CP) enable (0 : Power 5V[CP OFF] / 1 : Power3.3V[CP ON])
OPT_CENTX[6:0]	Optical center deviation register (Optical center address (x, y)=(13.5, 39.5)) -6.3~+6.3 step0.1 shows the positional deviation (Δx , Δy) of optical center. $\Delta = (-63 \sim +63) * 0.1$ X,Y each 7bit=7+7=14bit=2word remainder 2bit
OPT_CENTY[6:0]	
FAULT n X[5:0] (n : 1...32)	Defective pixel location notification register C=0-59, R=0-79 6bit+7bit. The number of defects can be written up to 32 pixels. (6+7)*32=416bit=52word
FAULT n Y[6:0] (n : 1...32)	Defective pixel location notification register C=0-59, R=0-79 6bit+7bit. The number of defects can be written up to 32 pixels. If there is no defects FAULT n Y[6:0] = '1111111'. (6+7)*32=416bit=52word
THER_OFFSET[7:0]	Offset adjustment of thermistor for substrate temperature measurement

11. Optical performance

11.1 Viewing image and data output

When the module is installed as shown Fig.11.1.1, the taken image of the subject is inverted to upside down and left and right as shown in Fig.11.1.2. Data captured by the sensors is output in the order shown in Fig.11.1.3.

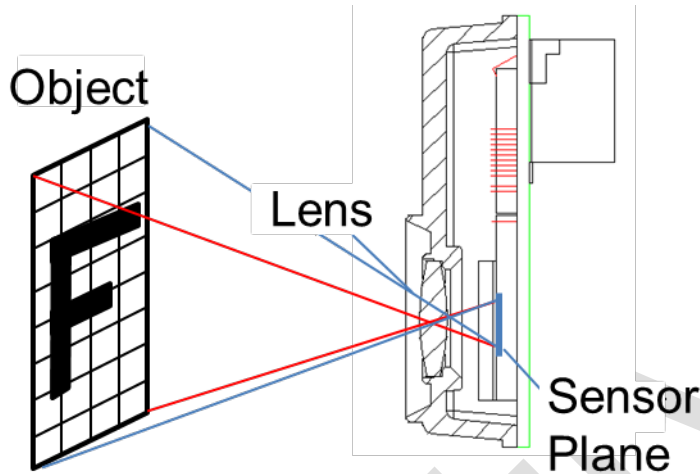

Fig.11.1.1 Relationship between module and subject

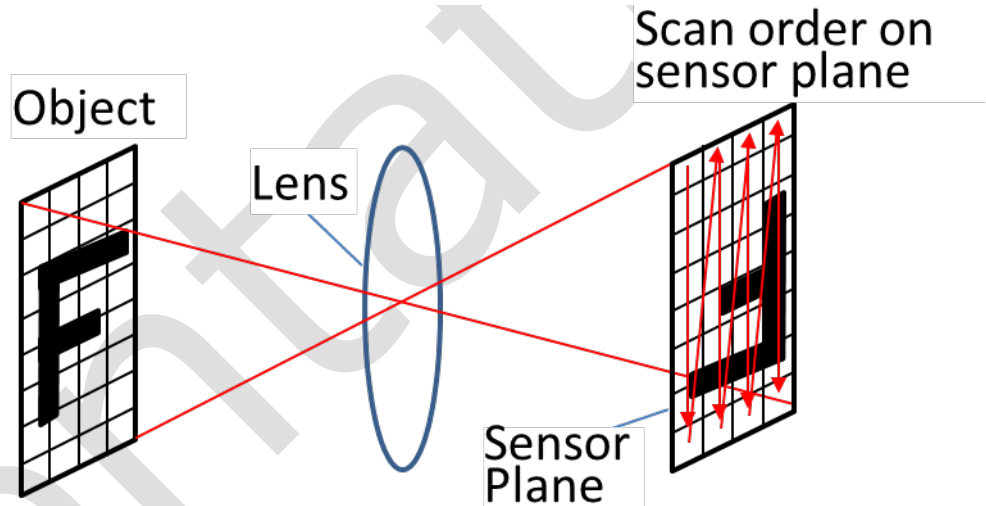

Fig.11.1.2 Relationship between image sensor and subject

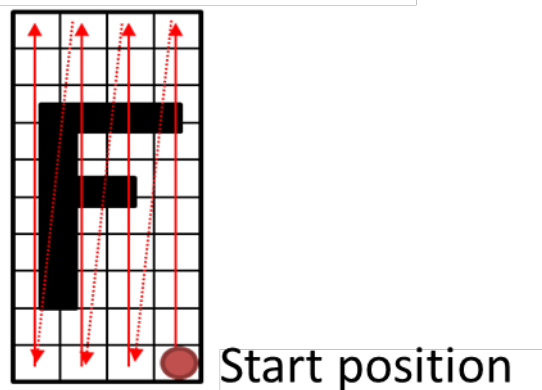

Fig.11.1.3 Direction of data output

12. Packing

- (1) Arrange the sensor modules on a conductive tray.
The quantity stored in the tray is 50 pieces. These are stored without missing.
- (2) Pile up the trays (1) 10 each. Use the empty tray at the top as a lid.
- (3) Put the piled up trays (2) between the stationary plates.
- (4) Band the trays sandwiched between the stationary plates in (3) with two tapes.
- (5) Put a label on the upper stationary plate. The product name, lot number, rank, total quantity and production date are written on the label.
- (6) Spread paper cushioning material at the bottom of the outer box. The banded trays (4) are wrapped with paper cushioning material around, then stored in outer box.



Fig.12.1 Module stored on tray



Fig.12.2 (4) Banded trays

13. Outline

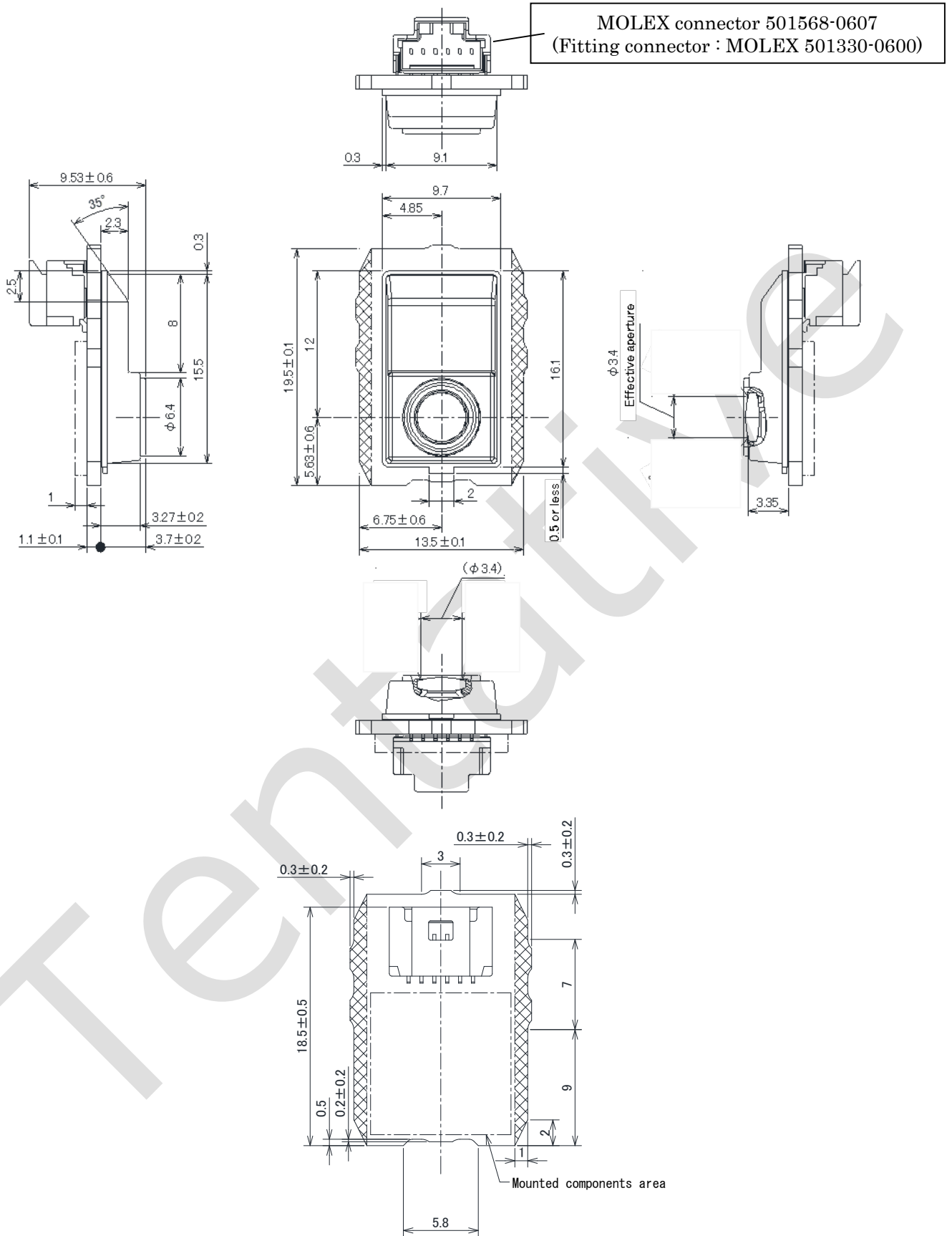

Fig.13.1 Outline

15. Safety Cautions for Use of Thermal diode infrared Sensor

15.1 General Cautions

(1) Mitsubishi Electric constantly strives to raise the level of its quality and reliability. Despite these concerted efforts, however, there will be occasions when our semiconductor products suffer breakdown, malfunction or other problems. In view of this reality, it is requested that every feasible precaution be taken in the pursuit of redundancy design, fire-spreading prevention design, malfunction prevention design and other safety-related designs, to prevent breakdowns or other problems, thereby upholding the highest levels of safety in the products when in use by customers. Particularly strict caution and observation is requested in the following areas.

(2) The product described in this document is not a medical device. In addition, it cannot be designed for special purposes such as transportation equipment (automobiles, trains, ships), aerospace, and nuclear power. Please contact Mitsubishi Electric or distributor when considering use for these purposes.

15.2 Shipping Methods

(1) During shipment, position the packing boxes to face in the right direction, and fix them firmly in place to avoid movement. Placing the boxes upside down or in positions that result in unnatural pressure can cause deformation in the connector, cap breakage or other problems.

(2) Never throw or drop the packing boxes. Sharp impact to the boxes can cause the elements to break.

(3) Take strict precautions to avoid getting the devices wet when shipping under conditions of rain and snow.

15.3 Storage Methods

When storing the devices, it is preferable to store them in the methods described below, without opening the packing. Failure to take ample care at such times can result in defects in electrical characteristics, soldering quality, external appearance and other areas. The major safety cautions are described below.

(1) Storage locations should be maintained within appropriate temperature and humidity ranges – namely, a so-called normal temperature range of 5~30°C, and humidity of 40~60 percent RH.

(2) The atmosphere for storage should be particularly free from the generation of toxic gases and have minimal dust.

(3) Store in conditions that prevent any weight from being placed on the element.

(4) Because storage in environments with drastic temperature changes can cause condensation in the element or packing, such locations should be avoided for storing. Instead, choose storage locations characterized by minimum temperature fluctuation.

15.4 Design and Use Environments

(1) Do not touch the lens as it may cause fluctuations or deterioration of optical performance.

(2) The lens cap made of resin and creep may deform the lens cap and degrade the optical performance. Therefore, design the lens cap so that it does not continuously apply a load to the lens cap during mounting,

(3) Avoid use in locations where water or organic solvents can become directly attached, or where there is any possibility of the generation of corrosive gas, explosive gas, dust, salinity and other troublesome conditions. Such environments will not only conspicuously lower reliability, but also harbor the potential of leading to serious accidents. And do not use in condensation, precipitation, or underwater environments.

(4) Maximum ratings may destroy the device. Therefore, even if the specified values is instantaneous, Please design not to exceed.

15.5 Static Electric Safety Cautions

This product is more prone to static electricity (ESD = electro-static discharge). Generation of ESD, meanwhile, can cause the element to break. When handling this product, please observe the following cautions.

<Static Electricity and Surge Countermeasures>

To prevent element breakage from static electricity or surge, please adopt the following countermeasures at the assembly line.

- (1) Machine ground all devices, machinery jigs and other items during the process. Take particular care with hot plates, solder irons and other items for which the commercial power supplies are prone to leakage.
- (2) Workers should always use earth bands. It is highly recommended, furthermore, that clothing difficult to be electrically charged, electric conduction shoes and other safety equipment be worn on the job.
- (3) Use conductive items for this product's container, etc.
- (4) It is recommended that grounding mats be placed on assembly line workbench surfaces, the floor in the immediate area, etc.
- (5) When mounting this product in parts or materials with the possibility of collecting electrical charges (printed wiring boards, plastic products, etc.), pay close attention to the static electricity in those parts. Collected charges can cause breakage in the product.
- (6) Work environment humidity should be controlled to maintain a minimum level of 40 percent RH.

These countermeasures are general in nature, and there is a need to amply confirm the line before commencing set mass production using this product (at the test production stage, etc.). For surge countermeasures, it is extremely important to prevent surge, and to quickly disperse any surge that does occur to prevent it from spreading.

15.6 Safety

- (1) Description of products using silicon is used in this product.
To prevent danger, never grind, plane, burn or chemically treat this product. Also, never put place product in your mouth or swallow it.

15.7 Intellectual Property

The purchase and use of this product are not meant to permit the transfer or permission of inventions, ideas, know-how, copyrights and other intellectual property rights or usage rights related to Mitsubishi Electric's confidential information.