

产品规格书

SPECIFICATION

客户名称:

Client Name

产品名称:

EMC5050 方杯 4.5W 综合版

Client P/N

产品型号:

LY-XE200205WH50B-XX-70

Product P/N

日期:

2022-7-11

Sending Date

核准 Approval	确认 Audit	制作 Confirmation
	支柱	谢荣
版本/Version	A1	

- 注: 1.此规格书以中英文方式书写, 若有冲突以中文版文本为准。
2.此规格书的最终解释权归由深圳市立洋光电股份有限公司。

 **LM-80 ISO9001:2015**



Model Explanation

型号介绍

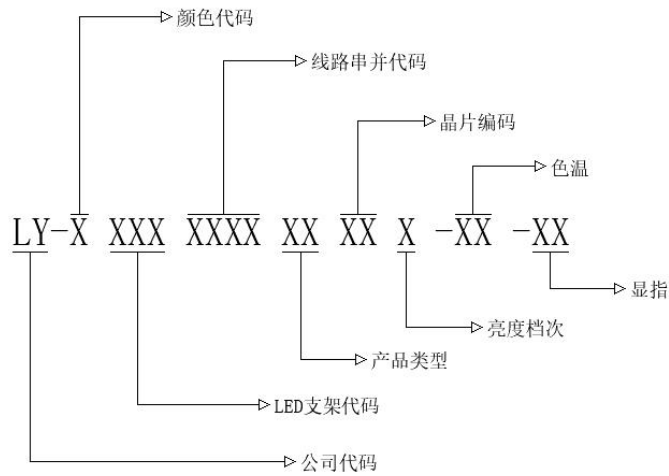

■Features

特征

- ◆ Series Parallel Combination Circuit/串并组合
- ◆ Low Thermal Resistance/低热阻
- ◆ Super Energy Efficiency/高光效
- ◆ Half Angle ($2\theta_{1/2}$): 120°/半功率角度: 120°
- ◆ RoHS Compliant.

■Applications

应用

- ◆ General Lighting/普通照明
- ◆ Advertisement/广告灯
- ◆ Architectural Lighting/建筑照明
- ◆ Street Lamps/路灯
- ◆ Other Lighting/其它照明

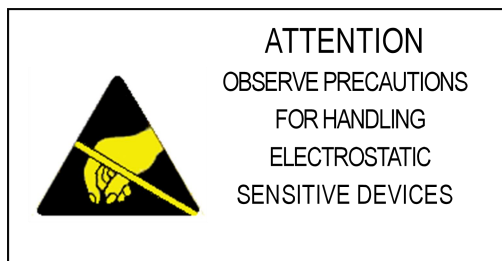

Package Dimensions 外观尺寸 (标识点为正极)

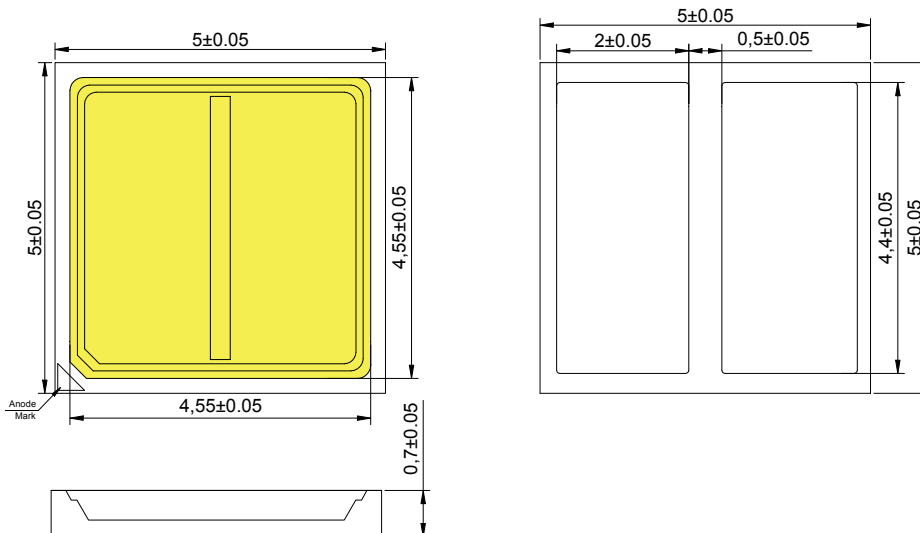

PCB 焊盘尺寸:

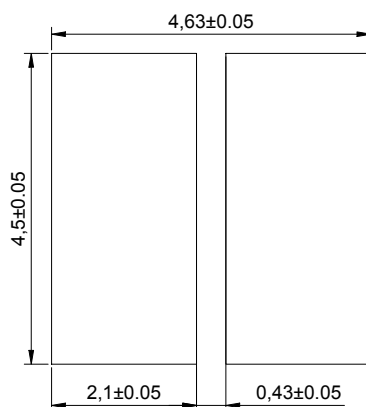

Equivalent circuit diagram

等效电路图: 2 串 5 并

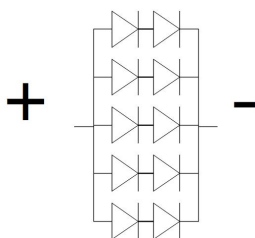

Notes:

1. All dimensions are in millimeters.
(所有尺寸以毫米为单位)
2. Tolerance is ± 0.25 unless otherwise noted
(未标注公差为: ± 0.25)



■ Absolute Maximum Rating(At TA=25°C)
(极限参数)

Parameter 参数	Symbol 符号	Value 数值	Units 单位
Power Dissipation 输入功率范围	P _I	5	W
Operating current range 正向电流范围	IF	800	mA
Junction Temperature 结点温度	T _J	120	°C
Operating Temperature Range 工作温度	T _{OPR}	-20°C To +80°C	
Storage Temperature Range 储存温度	T _{stg}	-40°C To +100°C	

■ 产品规格

功率 (W)	发光 颜色	色温 范围 (K)	产品型号	显色 指数 Ra.	Luminous Flux. 光通量 (LM)	电流 (mA)	电压 (V)
4.5	暖白光	2700K	LY-IE200205WH50B-27-70	70	730-780	750	5.8-6.2
4.5	暖白光	3000K	LY-IE200205WH50B-30-70	70	750-800	750	5.8-6.2
4.5	暖白光	3500K	LY-IE200205WH50B-35-70	70	780-830	750	5.8-6.2
4.5	中性白光	4000K	LY-NE200205WH50B-40-70	70	800-850	750	5.8-6.2
4.5	白光	5000K	LY-WE200205WH50B-50-70	70	800-850	750	5.8-6.2
4.5	白光	5700K	LY-WE200205WH50B-57-70	70	800-850	750	5.8-6.2
4.5	白光	6500K	LY-WE200205WH50B-65-70	70	800-850	750	5.8-6.2



Reliability

TEST ITEMS AND RESULTS

Test	Reference Standard	Test Condition	Test Duration	Failure Criteria	Units Failed/Tested
Temperature Cycle	JEITA ED-4701 100 105	-40°C(30min)~25°C(5min)~ 80°C(30min)~25°C(5min)	100cycles	#1	0/10
High Temperature Storage	JEITA ED-4701 200 201	T _A =100°C	1000hours	#1	0/10
Temperature Humidity Storage	JEITA ED-4701 100 103	T _A =85°C RH=85%	1000hours	#1	0/10
Low Temperature Storage	JEITA ED-4701 200 202	T _A =-40°C	1000hours	#1	0/10
Room Temperature Operating Life		T _A =25°C, I _F =750mA	1000hours	#1	0/10
High Temperature Operating Life		T _A =90°C, I _F =750mA	1000hours	#1	0/10

(2)Failure Criteria

Criteria#	Items	Conditions	Failure Criteria
#1	Forward Voltage(V _F)	I _F =750mA	>Initial value x 1.2
	Luminous Flux(Θ _v)	I _F =750mA	<Initial value x 0.7

U.S.L.:Upper Standard Level

L.S.L.:Lower Standard Level



Color Code BIN:

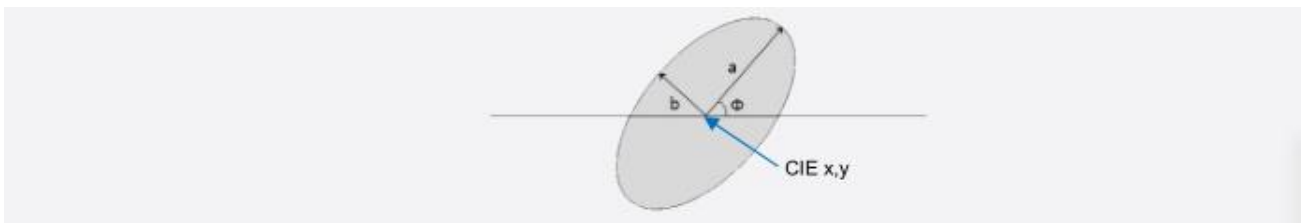
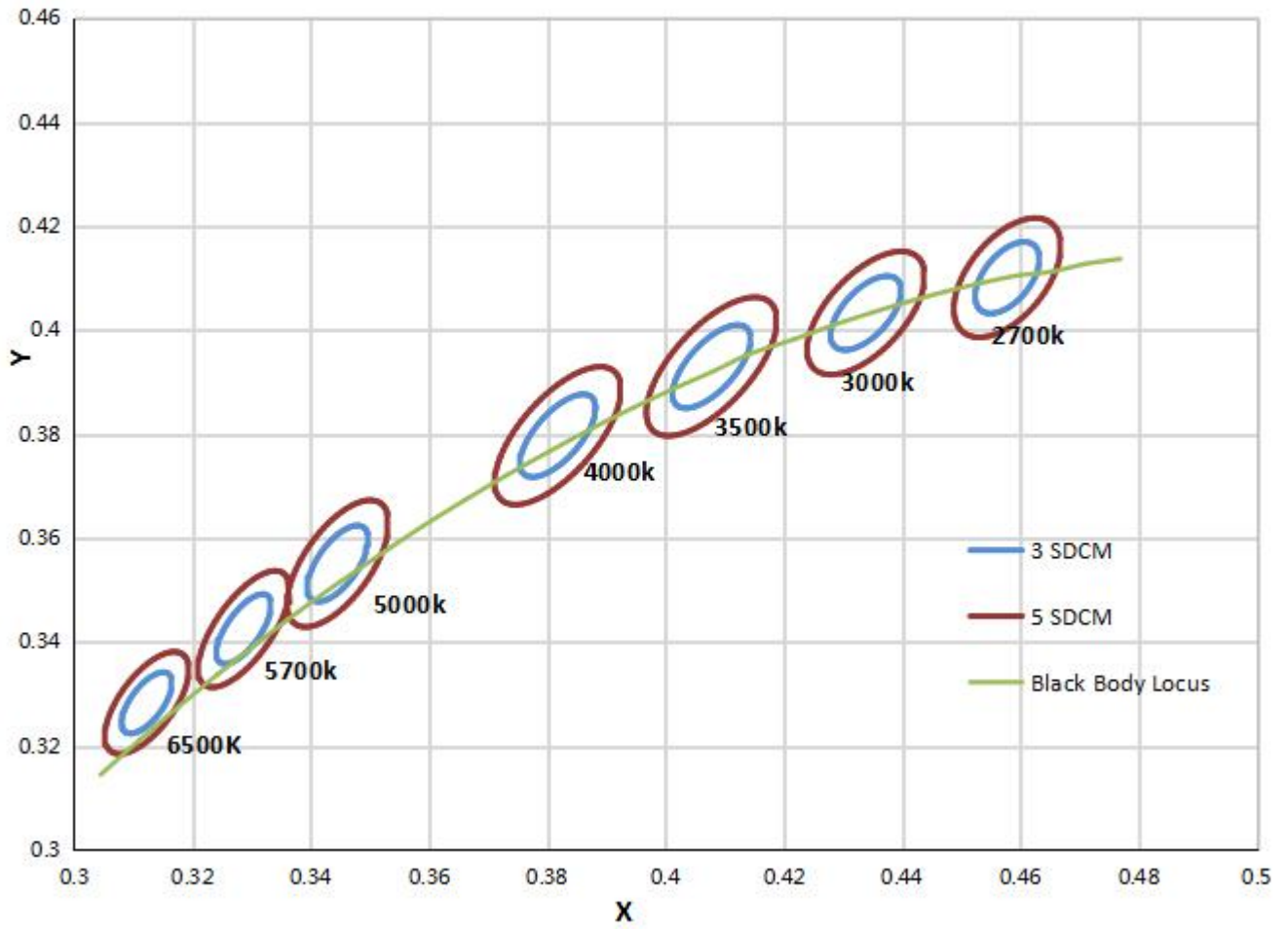

Mac Adam Ellipse

Mac Adam Ellipse (2700K)						Mac Adam Ellipse (3000K)					
Step	CIE X	CIE Y	θ	a	b	Step	CIE X	CIE Y	θ	a	b
3-step	0.4578	0.4101	53.7	0.0081	0.0042	3-step	0.4338	0.403	53.22	0.0083	0.0041
5-step	0.4578	0.4101	53.7	0.0135	0.007	5-step	0.4338	0.403	53.22	0.0139	0.0068

Mac Adam Ellipse (3500K)						Mac Adam Ellipse (4000K)					
Step	CIE X	CIE Y	θ	a	b	Step	CIE X	CIE Y	θ	a	b
3-step	0.4073	0.3917	54	0.00927	0.00414	3-step	0.3818	0.3797	53.72	0.00939	0.00402
5-step	0.4073	0.3917	54	0.01545	0.0069	5-step	0.3818	0.3797	53.72	0.01565	0.0067

Mac Adam Ellipse (5000K)						Mac Adam Ellipse (5700K)					
Step	CIE X	CIE Y	θ	a	b	Step	CIE X	CIE Y	θ	a	b
3-step	0.3447	0.3553	59.62	0.0082	0.0035	3-step	0.3287	0.3417	59.09	0.00746	0.0032
5-step	0.3447	0.3553	59.62	0.0137	0.0059	5-step	0.3287	0.3417	59.09	0.01243	0.00533

Mac Adam Ellipse (6500K)											
Step	CIE X	CIE Y	θ	a	b						
3-step	0.3123	0.3282	58.57	0.00669	0.00285						
5-step	0.3123	0.3282	58.57	0.01115	0.00475						

Note:

maintains measurement tolerance of: Cx, Cy = ±0.005



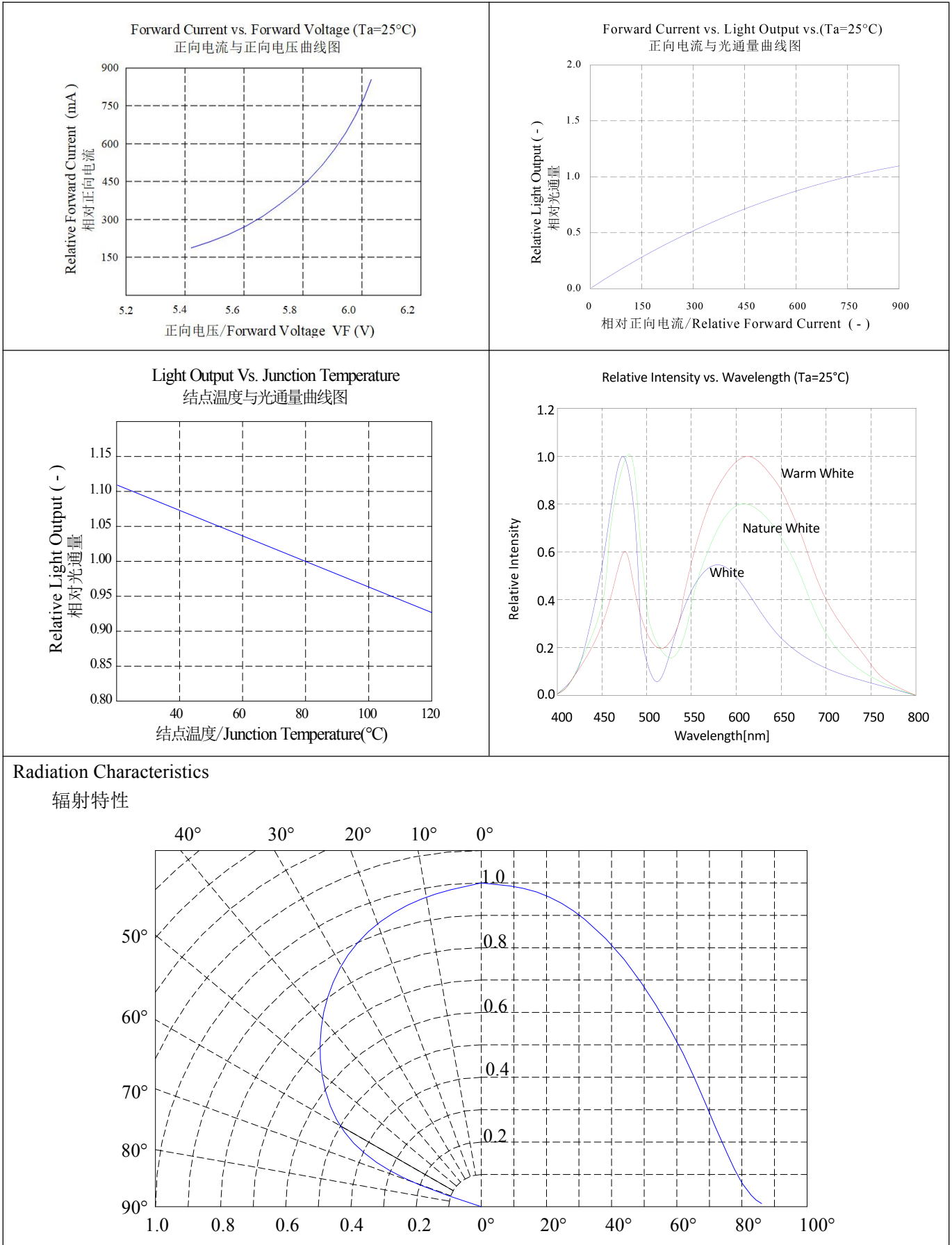

包装说明

Label 标签

P/N: 产品型号	<div style="border: 1px solid black; padding: 10px; text-align: center;"> <p>深圳市立洋光电子有限公司</p> <p>P/N: _____</p> <p>VF: _____ IF: _____</p> <p>BIN Code/CCT: _____</p> <p>IV: _____ Q' TY: _____</p> <p>  *XXXXXXXXXXXX* </p> <p>ROHS</p> </div>
VF: 正向电压	
IF: 额定驱动电流	
BIN Code/CCT: 色区/色温	
IV: 流明等级	
Q'TY: 数量	

载带包装图

产品载带示意图

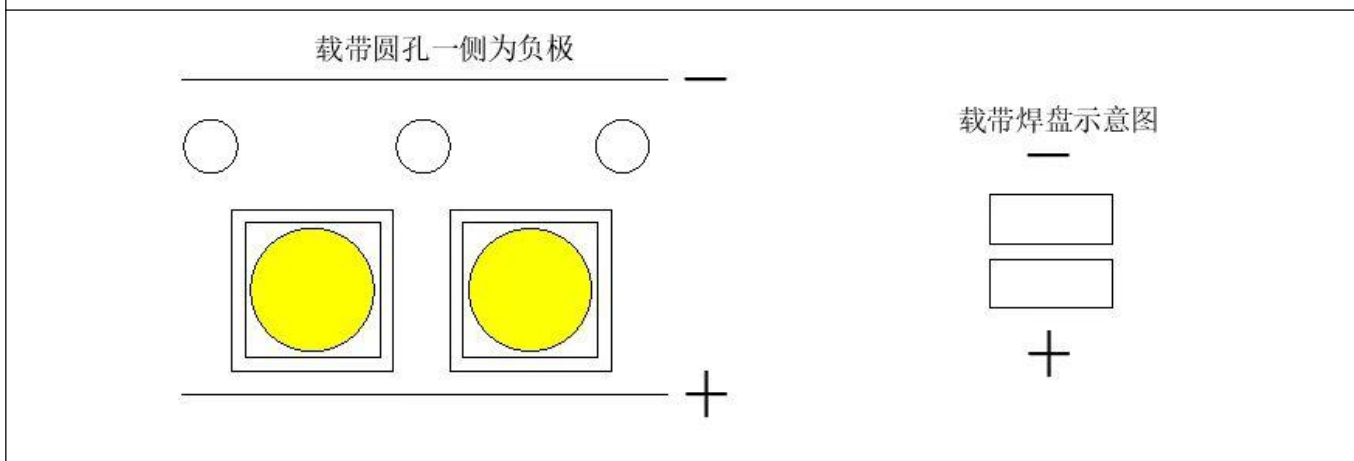

包装: 7"卷盘/2K

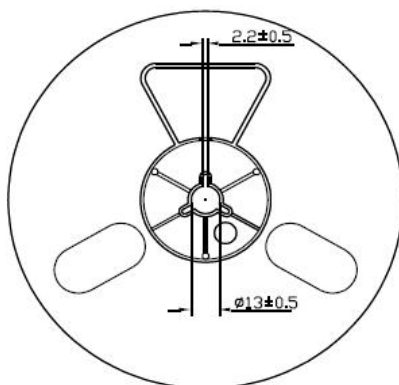

回流焊接条件

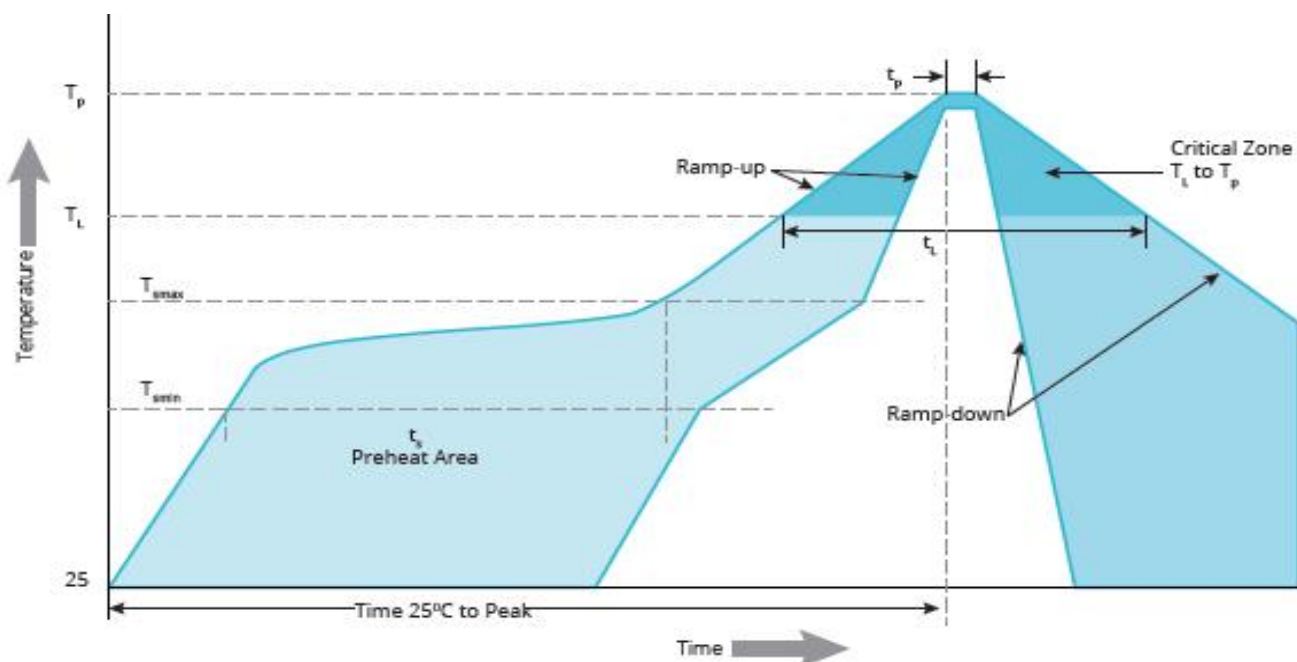

回流焊曲线说明:

特特征	无铅中温焊接	无铅高温焊接
预热: 最小温度 (T _{smin})	120°C	150°C
预热: 最大温度 (T _{smax})	160°C	200°C
预热: 时间 (t _{smin} to t _{smax})	60-150 秒	60-150 秒
在以上温度保持: 温度(T _L)	180°C	217°C
在以上时间保持: 时间(T _L)	30-60 秒	30-60 秒
峰值温度	210°C	260°C
实际峰值温度维持±5°C内的时间	20-30 秒	5-10 秒
温度下降斜率	6°C/秒 (最大)	6°C/秒 (最大)
常温 25°C到峰值温度	6 分钟内	6 分钟内
注意事项:		
A. 中温、高温无铅回流焊建议的温度曲线如上图, 杜绝最高温度超过 (高温: 260°C/10S), (中温: 210°C/30S)		
B. 调试合适的温度, 选择对应的锡膏, 务必先做首件确认。		
C. 以上温度以实际炉温为准。		
D. 建议选择高温锡膏, 对应高温回流焊曲线。		

