



PROPRIETARY NOTE

THIS SPECIFICATION IS THE PROPERTY OF BOE SDT AND SHALL NOT BE REPRODUCED OR COPIED WITHOUT THE WRITTEN PERMISSION OF BOE SDT AND MUST BE RETURNED TO BOE SDT UPON ITS REQUEST

SPEC. NUMBER

PRODUCT GROUP

Rev. 0

ISSUE DATE

Mar. 31. 17'

PAGE

1 OF 30

TITLE : MV238QUM-N20T

Preliminary Product Specification

Rev. 0

Beijing BOE Special Display Technology Co.,Ltd.

Contents

No.	Item	Page
1.0	General Description	4
2.0	Absolute Maximum Ratings	6
3.0	Electrical Specifications	7
4.0	Optical Specifications	8
5.0	Interface Connection	10
6.0	Signal Timing Specifications	13
7.0	Signal Timing Waveforms of Interface Signal	15
8.0	Input Signals, Display Colors & Gray Scale of Colors	17
9.0	Power Sequence	18
10.0	Mechanical Characteristics	19
11.0	Reliability Test	20
12.0	Handling& Cautions	21
13.0	Product Serial Number	22
14.0	Packing	23
15.0	Appendix	25

1.0 GENERAL DESCRIPTION

1.1 Introduction

MV238QUM-N20T is a color active matrix TFT LCD module using amorphous silicon TFT's (Thin Film Transistors) as an active switching devices. This module has a 23.8 inch diagonally measured active area with UHD resolutions (3840 horizontal by 2160 vertical pixel array). Each pixel is divided into RED, GREEN, BLUE dots which are arranged in vertical stripe and this module can display 1.07B colors. The TFT-LCD panel used for this module is adapted for a low reflection and higher color type.

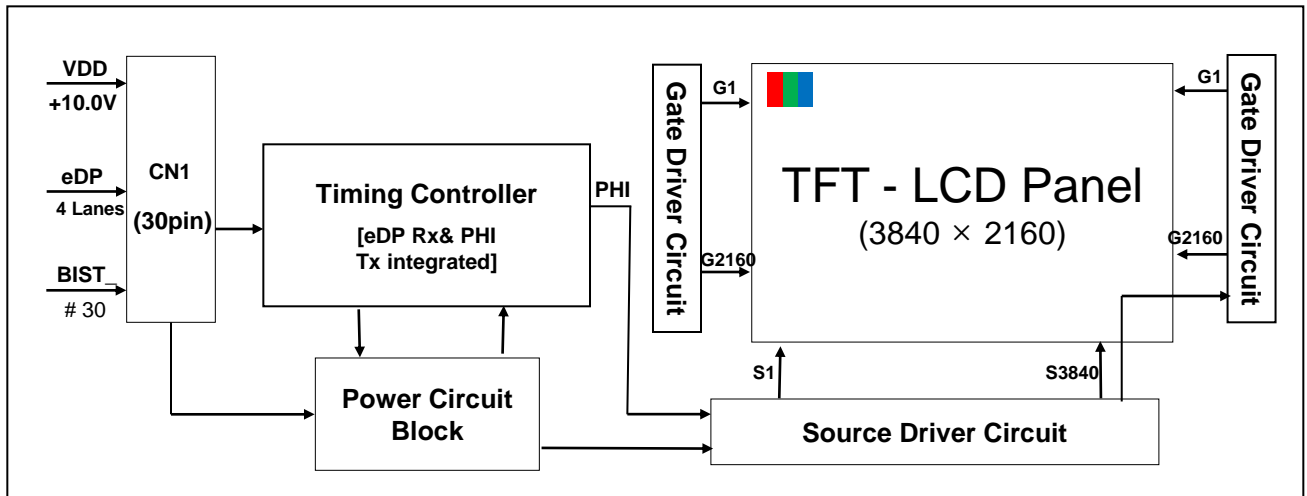

1.2 Features

- Reverse Type
- 4 lane eDP Interface with 5.4Gbps Link Rates
- High-speed response
- 10bit (8bit+H-FRC) color depth, display 1.07B colors
- Incorporated edge type back-light (LED)
- Compatible with sRGB 99% & NTSC75%
- High luminance and contrast ratio, low reflection and wide viewing angle
- RoHS/Halogen Free
- TCO 6.0, ES 6.0 compliant
- Gamma Correction

1.3 Application

- Desktop Type of PC & Workstation Use
- Slim-Size Display for Stand-alone Monitor
- Display Terminals for Control System
- Monitors for Process Controller

1.4 General Specification

The followings are general specifications at the model MV238QUM-N20T.

<Table 1. General Specifications>

Parameter	Specification	Unit	Remarks
Active area	527.04 (H) × 296.46(V)	mm	
Number of pixels	3840(H) × 2160(V)	pixels	
Pixel pitch	0.13725(H) × 0.13725(V)	mm	
Pixel arrangement	RGB Vertical stripe		
Display colors	1.07B	colors	
Display mode	Normally Black		
Dimensional outline	545.0 (H) × 323.4(V) × 12.5(D) typ.	mm	
Weight	2300 (Typ.)	g	
Surface Treatment	Haze 25%, 3H		
Back-light	Edge side, 1-LED Lighting Bar type		Note 1
Power Consumption	P_D : 6.8 (max)		
	P_{BL} : 20.02W (max)		Note 2
	P_{total} : 26.82 (max)		

Notes : 1. LED Lighting Bar (4*input pins)

2. $P_{LED} = \text{Input pins} * V_{PIN} \times I_{PIN}$

2.0 ABSOLUTE MAXIMUM RATINGS

The followings are maximum values which, if exceed, may cause faulty operation or damage to the unit. The operational and non-operational maximum voltage and current values are listed in Table 2.

< Table 2. Absolute Maximum Ratings >

[VSS=GND=0V]

Parameter	Symbol	Min.	Max.	Unit	Remarks
Power Supply Voltage	V _{DD}	-0.3	12.0	V	Ta = 25 °C
Logic Supply Voltage	V _{IN}	VSS-0.3	V _{DD} +0.3	V	
LED Light Bar Current Per Input Pin	IPIN	-	110	mA	Typ: 105mA
LED Light Bar Voltage Per Input Pin	VPIN	39.9	45.5	V	
Operating Temperature	T _{OP}	0	+50	°C	Note 1)
Storage Temperature	T _{ST}	-20	+60	°C	Note 1)
LCM Surface Temperature (Operation)	T _{surface}	0	+65	°C	Note 2)

Note : 1) Temperature and relative humidity range are shown in the figure below.

Wet bulb temperature should be 39 °C max. and no condensation of water.

2) LCM Surface Temperature should be Min. 0°C and Max. 65°C under the VLCD=5.0V, fV=60Hz, 25°C ambient Temp. No humidity control and LED string current is typical Value.

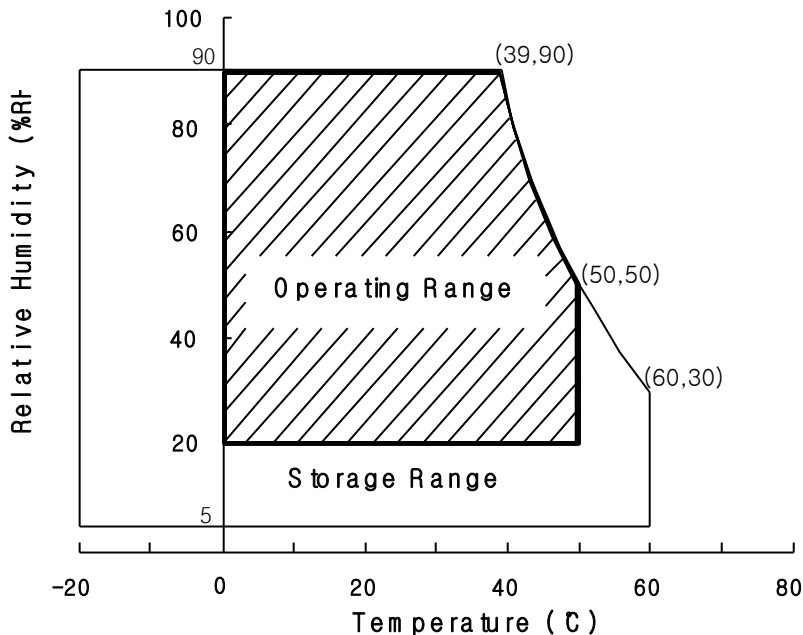

3.0 ELECTRICAL SPECIFICATIONS

3.1 Electrical Specifications

< Table 3. Electrical specifications >

[Ta =25±2 °C]

Parameter		Min.	Typ.	Max.	Unit	Remarks
Power Supply Voltage	V _{DD}	9	10.0	11	V	Note 1
Power Supply Current	I _{DD}	-	410	560	mA	
In-Rush Current	I _{RUSH}	-	2.0	3.0	A	Note 2
Permissible Input Ripple Voltage	V _{RF}	-	-	400	mV	V _{DD} = 10.0V
High Level Differential Input Threshold Voltage	V _{IH}	-	-	+100	mV	
Low Level Differential Input Threshold Voltage	V _{IL}	-100	-	-	mV	
Differential input voltage	V _{ID}	100	-	600	mV	
Rx input common mode voltage	V _{cm}	0	-	2		V _{IH} =100mV, V _{IL} =-100mV
Power Consumption	P _D	-	3	6.8	W	
	P _{BL}	15.96	17.9	20.02	W	Note 3
	P _{total}	-	20.9	26.82	W	

Notes: 1. The supply voltage is measured and specified at the interface connector of LCM.
The current draw and power consumption specified is for VDD=10.0V, Frame rate=60Hz

Test Pattern of power supply current

- a) Typ : Mosaic Pattern
- b) Max : 1 line Inversion

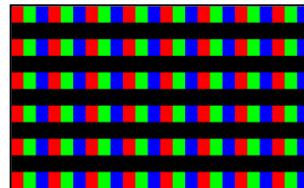

- 2. Duration of rush current is about 2 ms and rising time of VDD is 1ms(min).
- 3. Calculated value for reference (Input pins*VPIN × IPIN) excluding inverter loss.

3.2 Backlight Unit

< Table 4. LED Backlight Unit >

Parameter		Min.	Typ.	Max.	Unit	Remarks
LED Light Bar Input Voltage Per Input Pin	VPIN	39.9	42.7	45.5	V	Duty 100%
LED Light Bar Input Current Per Input Pin	IPIN	100	105	110	mA	Note1,2,
LED Power Consumption	P _{BL}	15.96	17.9	20.02	W	Note 3
LED Life-Time	-	30,000	-		Hrs	Note 4

Note1: There are one light bar ,and the specified current is input LED chip 100% duty current

Note2: The sense current of each input pin is 105mA

Note3: $P_{BL}=4 \text{ Input pins} \times V_{PIN} \times I_{PIN}$

Note4: The lifetime is determined as the time at which luminance of LED become 50% of the initial brightness or not normal lighting at $I_{PIN}=120\text{mA}$ on condition of continuous operating at $25 \pm 2^\circ \text{C}$

4.0 OPTICAL SPECIFICATION

4.1 Overview

The test of Optical specifications shall be measured in a dark room (ambient luminance ≤ 1 lux and temperature = $25 \pm 2^\circ\text{C}$) with the equipment of Luminance meter system (Goniometer system and TOPCONE BM-5) and test unit shall be located at an approximate distance 50cm from the LCD surface at a viewing angle of θ and Φ equal to 0° . We refer to $\theta_{\phi=0}$ ($=\theta_3$) as the 3 o'clock direction (the "right"), $\theta_{\phi=90}$ ($=\theta_{12}$) as the 12 o'clock direction ("upward"), $\theta_{\phi=180}$ ($=\theta_9$) as the 9 o'clock direction ("left") and $\theta_{\phi=270}$ ($=\theta_6$) as the 6 o'clock direction ("bottom"). While scanning θ and/or ϕ , the center of the measuring spot on the Display surface shall stay fixed. The measurement shall be executed after 30 minutes warm-up period. VDD shall be 5.0V +/-10% at 25°C . Optimum viewing angle direction is 6 'clock.

4.2 Optical Specifications

[VDD = 5.0V, Frame rate = 60Hz, Clock = 74.25MHz, $I_{BL} = 260\text{mA}$, $T_a = 25 \pm 2^\circ\text{C}$]

Parameter		Symbol	Condition	Min.	Typ.	Max.	Unit	Remark
Viewing Angle range	Horizontal	θ_3	CR > 10	85	89	-	Deg.	Note 1
		θ_9		85	89	-	Deg.	
	Vertical	θ_{12}		85	89	-	Deg.	
		θ_6		85	89	-	Deg.	
Luminance Contrast ratio		CR	$\theta = 0^\circ$ (Center) Normal Viewing Angle	700	1000			Note 2
Luminance of White		Y_w		240	300		cd/m ²	Note 3
White luminance uniformity		ΔY		75	80		%	Note 4
Reproduction of color	White	W_x		0.283	0.313	0.343	-	Note 5
		W_y		0.299	0.329	0.359	-	
	Red	R_x		TBD	TBD	TBD	-	
		R_y		TBD	TBD	TBD	-	
	Green	G_x	TBD	TBD	TBD	-		
		G_y	TBD	TBD	TBD	-		
Blue	B_x	TBD	TBD	TBD	-			
	B_y	TBD	TBD	TBD	-			
Response Time	GTG	T_g		14	20	ms	Note 6	
Cross Talk		CT		-	-	2.0	%	Note 7

Note :

1. Viewing angle is the angle at which the contrast ratio is greater than 10. The viewing are determined for the horizontal or 3, 9 o'clock direction and the vertical or 6, 12 o'clock direction with respect to the optical axis which is normal to the LCD surface.
2. Contrast measurements shall be made at viewing angle of $\theta = 0^\circ$ and at the center of the LCD surface. Luminance shall be measured with all pixels in the view field set first to white, then to the dark (black) state. (See FIGURE 1 shown in Appendix) Luminance Contrast Ratio (CR) is defined mathematically.

$$CR = \frac{\text{Luminance when displaying a white raster}}{\text{Luminance when displaying a black raster}}$$

3. Center Luminance of white is defined as the LCD surface. Luminance shall be measured with all pixels in the view field set first to white. This measurement shall be taken at the locations shown in FIGURE 2 for a total of the measurements per display.
4. The White luminance uniformity on LCD surface is then expressed as :
 $\Delta Y = (\text{Minimum Luminance of 9points} / \text{Maximum Luminance of 9points}) * 100$
 (See FIGURE 2 shown in Appendix).
5. The color chromaticity coordinates specified in Table 4. shall be calculated from the spectral data measured with all pixels first in red, green, blue and white. Measurements shall be made at the center of the panel.
6. Response time Tg is the average time required for display transition by switching the input signal as below table and is based on Frame rate fV =60Hz to optimize.
 Each time in below table is defined as Figure 3and shall be measured by switching the input signal for “any level of gray(bright)”and “any level of gray(dark)”.
 (See FIGURE 3 shown in Appendix).
7. Cross-Talk of one area of the LCD surface by another shall be measured by comparing the luminance (Y_A) of a 25mm diameter area, with all display pixels set to a gray level, to the luminance (Y_B) of that same area when any adjacent area is driven dark. (See FIGURE 4 shown in Appendix).

5.0 INTERFACE CONNECTION.

5.1 Electrical Interface Connection

5.1.1 LED Light Bar

< Table 1. LED Light Bar >

Pin No	Symbol	Description
1	IRLED1	LED current sense for string1
2	IRLED2	LED current sense for string2
3	VLED	LED power supply
4	VLED	LED power supply
5	IRLED3	LED current sense for string3
6	IRLED4	LED current sense for string4
7	CONNECTOR	3708K-Q06N-00L

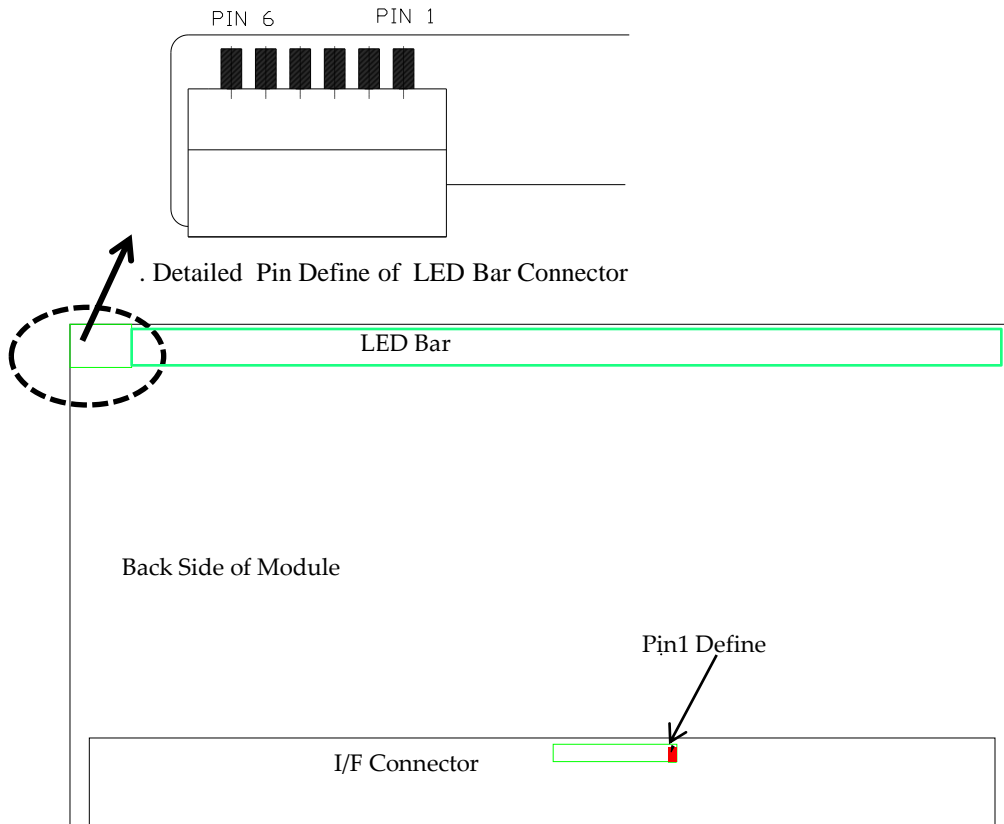

Figure1. Back Side of Module

5.0 INTERFACE CONNECTION.

5.1 Electrical Interface Connection

- CN1 Module Side Connector : UJU IS050-L30B-C10 or Equivalent

Pin No	Symbol	Function	Remark
1	VDD	Power Supply (10.0V)	
2	VDD	Power Supply (10.0V)	
3	VDD	Power Supply (10.0V)	
4	VDD	Power Supply (10.0V)	
5	VDD	Power Supply (10.0V)	
6	GND	Ground	
7	GND	Ground	
8	NC	No connection	
9	NC	No connection	
10	GND	Ground	
11	HPD	Hot Plug Detection Signal	
12	GND	Ground	
13	DAUXN	AUX_CHN Component Signal for Auxiliary Channel	
14	DAUXP	AUX_CHP True Signal for Auxiliary Channel	
15	GND	Ground	
16	DRX0P	Lane3P True Signal for Main Link 0	
17	DRX0N	Lane3N Component Signal for Main Link 0	
18	GND	Ground	
19	DRX1P	Lane3P True Signal for Main Link 1	
20	DRX1N	Lane3N Component Signal for Main Link 1	
21	GND	Ground	
22	DRX2P	Lane3P True Signal for Main Link 2	
23	DRX2N	Lane3N Component Signal for Main Link 2	
24	GND	Ground	
25	DRX3P	Lane3P True Signal for Main Link 3	
26	DRX3N	Lane3N Component Signal for Main Link 3	
27	GND	Ground	
28	GND	Ground	
29	NC	No connection	
30	BIST	BIST Function	

5.2 eDP Interface

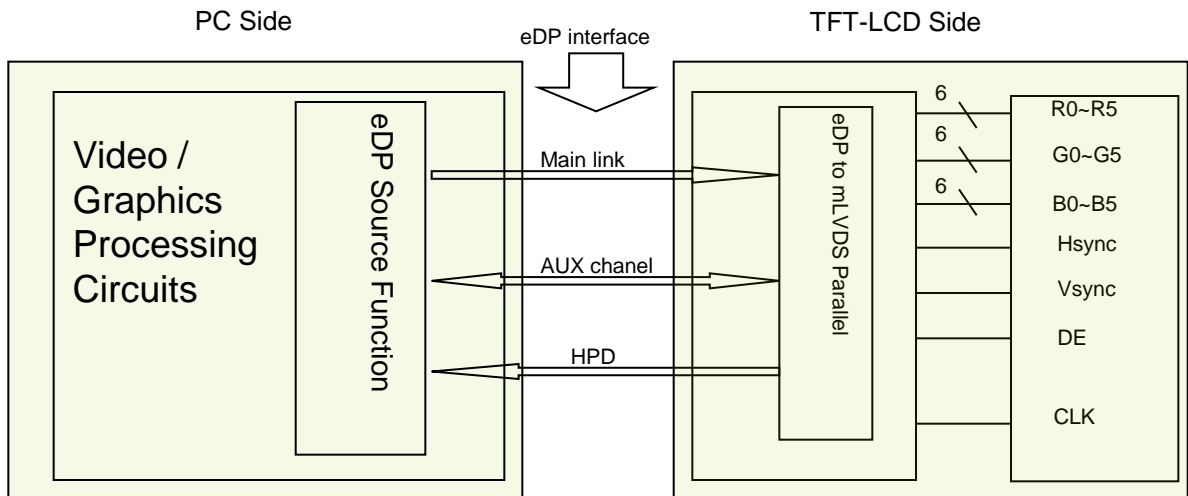

Note. Transmitter : Parade DP501 or equivalent.

Transmitter is not contained in Module.

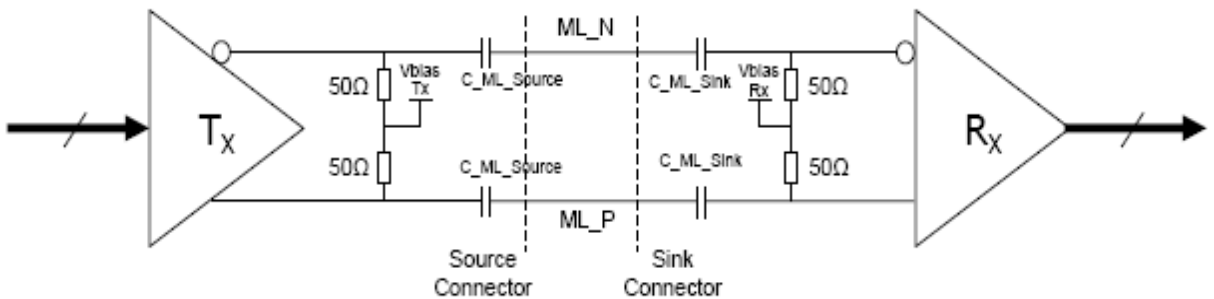

eDP Main Link differential pair

5.3 Data Input Format

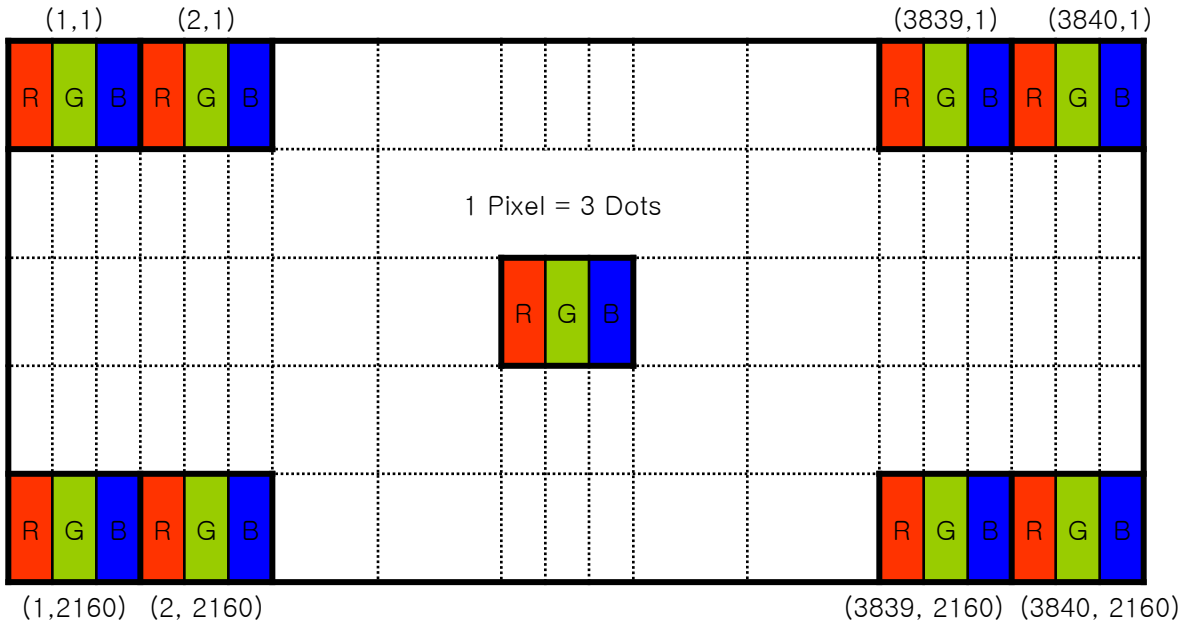

Display Position of Input Data (V-H)

6.0 SIGNAL TIMING SPECIFICATION

6.1 The MV238QUM-N20T is operated by the DE only.

Item		Symbols	Min	Typ	Max	Unit
Clock	Frequency	1/Tc	-	140	-	MHz
	High Time	Tch	-	4/7Tc	-	
	Low Time	Tcl	-	4/7Tc	-	
Frame Period		Tv	-	2222	-	lines
			50	60	62	Hz
			20	16.7	16.13	ms
Vertical Display Period		Tvd	-	2160	-	lines
One line Scanning Period		Th	-	4200	-	clocks
Horizontal Display Period		Thd	-	3840	-	clocks

6.2 eDP Rx Interface Timing Parameter

The specification of the eDP Rx interface timing parameter is shown in Table 4.

<Table 4. eDP Rx Interface Timing Specification>

Item	Symbol	Min	Typ	Max	Unit	Remark
Spread spectrum clock	ssc		0.5		%	
Differential peak-to-peak input voltage at package pins	VRX-DIFFp-p	100	0	1320	mV	
Rx input DC common mode voltage	VRX_DC_CM	-	GND	-	V	
Differential termination resistance	RRX-DIFF	80	-	100	Ω	
Single-ended termination resistance	RRX-SE	40	-	60	Ω	
Rx short circuit current limit	IRX_SHORT	-	-	20	mA	
Intra-pair skew at Rx package pins (HBR) RX intra-pair skew tolerance at HBR	LRX_SKEW_INTRA_PAIR	-	-	150	ps	

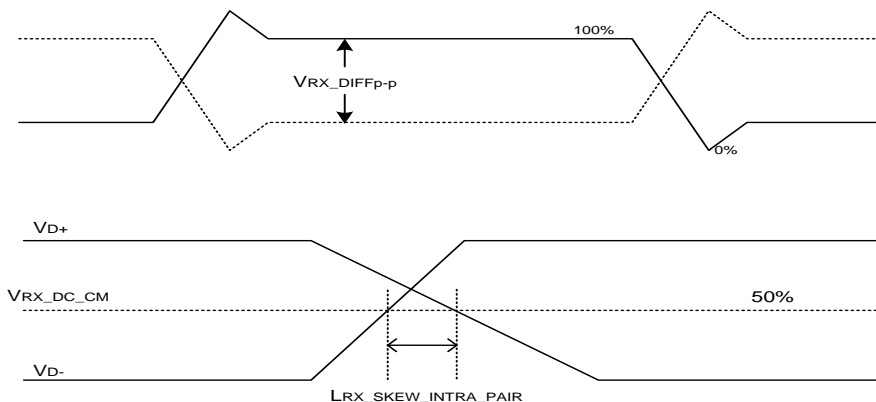

7.0 INPUT SIGNALS, BASIC DISPLAY COLORS & GRAY SCALE OF COLORS

Color & Gray Scale		RED DATA								GREEN DATA								BLUE DATA							
		R7	R6	R5	R4	R3	R2	R1	R0	G7	G6	G5	G4	G3	G2	G1	G0	B7	B6	B5	B4	B3	B2	B1	B0
Basic Colors	Black	0	0	0	0	0	0	0	0	0	0	0	0	0	0	0	0	0	0	0	0	0	0	0	0
	Blue	0	0	0	0	0	0	0	0	0	0	0	0	0	0	0	0	1	1	1	1	1	1	1	1
	Green	0	0	0	0	0	0	0	0	1	1	1	1	1	1	1	1	0	0	0	0	0	0	0	0
	Cyan	0	0	0	0	0	0	0	0	1	1	1	1	1	1	1	1	1	1	1	1	1	1	1	1
	Red	1	1	1	1	1	1	1	1	0	0	0	0	0	0	0	0	0	0	0	0	0	0	0	0
	Magenta	1	1	1	1	1	1	1	1	0	0	0	0	0	0	0	0	1	1	1	1	1	1	1	1
	Yellow	1	1	1	1	1	1	1	1	1	1	1	1	1	1	1	1	0	0	0	0	0	0	0	0
	White	1	1	1	1	1	1	1	1	1	1	1	1	1	1	1	1	1	1	1	1	1	1	1	1
Gray Scale of RED	Black	0	0	0	0	0	0	0	0	0	0	0	0	0	0	0	0	0	0	0	0	0	0	0	0
	△	0	0	0	0	0	0	0	1	0	0	0	0	0	0	0	0	0	0	0	0	0	0	0	0
	Darker	0	0	0	0	0	0	1	0	0	0	0	0	0	0	0	0	0	0	0	0	0	0	0	0
	△	↑								↑								↑							
	▽	↓								↓								↓							
	Brighter	1	1	1	1	1	1	0	1	0	0	0	0	0	0	0	0	0	0	0	0	0	0	0	0
	▽	1	1	1	1	1	1	1	0	0	0	0	0	0	0	0	0	0	0	0	0	0	0	0	0
	Red	1	1	1	1	1	1	1	1	0	0	0	0	0	0	0	0	0	0	0	0	0	0	0	0
Gray Scale of GREEN	Black	0	0	0	0	0	0	0	0	0	0	0	0	0	0	0	0	0	0	0	0	0	0	0	0
	△	0	0	0	0	0	0	0	0	0	0	0	0	0	0	0	1	0	0	0	0	0	0	0	0
	Darker	0	0	0	0	0	0	0	0	0	0	0	0	0	0	1	0	0	0	0	0	0	0	0	0
	△	↑								↑								↑							
	▽	↓								↓								↓							
	Brighter	0	0	0	0	0	0	0	0	1	1	1	1	1	1	0	1	0	0	0	0	0	0	0	0
	▽	0	0	0	0	0	0	0	0	1	1	1	1	1	1	1	0	0	0	0	0	0	0	0	0
	Green	0	0	0	0	0	0	0	0	1	1	1	1	1	1	1	1	0	0	0	0	0	0	0	0
Gray Scale of BLUE	Black	0	0	0	0	0	0	0	0	0	0	0	0	0	0	0	0	0	0	0	0	0	0	0	0
	△	0	0	0	0	0	0	0	0	0	0	0	0	0	0	0	0	0	0	0	0	0	0	0	1
	Darker	0	0	0	0	0	0	0	0	0	0	0	0	0	0	0	0	0	0	0	0	0	0	0	1
	△	↑								↑								↑							
	▽	↓								↓								↓							
	Brighter	0	0	0	0	0	0	0	0	0	0	0	0	0	0	0	0	1	1	1	1	1	1	0	1
	▽	0	0	0	0	0	0	0	0	0	0	0	0	0	0	0	0	1	1	1	1	1	1	1	0
	Blue	0	0	0	0	0	0	0	0	0	0	0	0	0	0	0	0	1	1	1	1	1	1	1	1
Gray Scale of WHITE	Black	0	0	0	0	0	0	0	0	0	0	0	0	0	0	0	0	0	0	0	0	0	0	0	0
	△	0	0	0	0	0	0	0	1	0	0	0	0	0	0	0	1	0	0	0	0	0	0	0	1
	Darker	0	0	0	0	0	0	1	0	0	0	0	0	0	0	1	0	0	0	0	0	0	0	1	0
	△	↑								↑								↑							
	▽	↓								↓								↓							
	Brighter	1	1	1	1	1	1	0	1	1	1	1	1	1	1	0	1	1	1	1	1	1	1	0	1
	▽	1	1	1	1	1	1	1	0	1	1	1	1	1	1	1	0	1	1	1	1	1	1	1	0
	White	1	1	1	1	1	1	1	1	1	1	1	1	1	1	1	1	1	1	1	1	1	1	1	1

9.0 POWER SEQUENCE

To prevent a latch-up or DC operation of the LCD module, the power on/off sequence shall be as shown in below

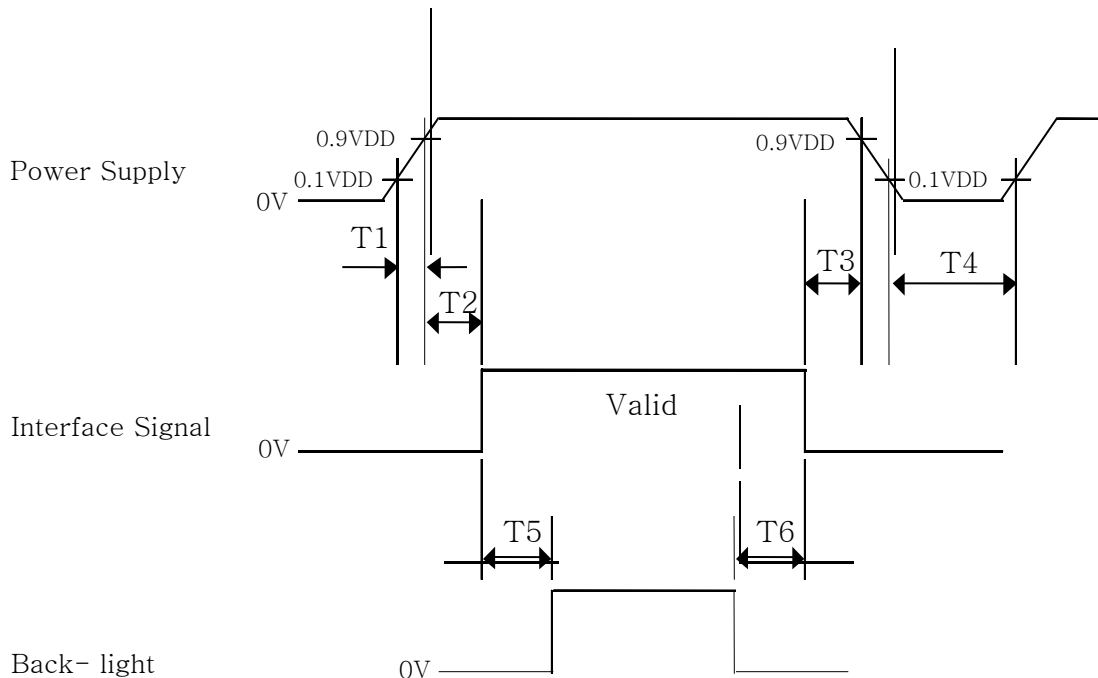

- $0.5 \text{ ms} \leq T1 \leq 10 \text{ ms}$
- $0 \leq T2 \leq 50 \text{ ms}$
- $0 \leq T3 \leq 50 \text{ ms}$
- $1 \text{ sec} \leq T4$
- $200 \text{ ms} \leq T5$
- $200 \text{ ms} \leq T6$

Notes:

1. When the power supply VDD is 0V, keep the level of input signals on the low or keep high impedance.
2. Do not keep the interface signal high impedance when power is on.
3. Back Light must be turn on after power for logic and interface signal are valid.

10.0 MECHANICAL CHARACTERISTICS

10.1 Dimensional Requirements

FIGURE 6 (located in Appendix) shows mechanical outlines for the model MV238QUM-N20T. Other parameters are shown in Table 5.

<Table 5. Dimensional Parameters>

Parameter	Specification	Unit
Dimensional outline	545.0 (H) × 323.4 (V) × 12.5(D) typ.	mm
Weight	2300(typ.)	gram
Active area	527.04 (H) × 296.46 (V)	mm
Pixel pitch	0.13725 (H) × 0.13725 (V)	mm
Number of pixels	3840 (H) × 2160 (V) (1 pixel = R + G + B dots)	pixels
Back-light	Edge side, 1-LED Lighting Bar type	

10.2 Mounting

Left & Right each side have two user holes, Back side have four user holes.(See MDL Mechanical Drawing).

(See MDL Mechanical Drawing).

10.3 Anti-Glare and Polarizer Hardness.

The surface of the LCD has an anti-glare coating to minimize reflection and a coating to reduce scratching.

10.4 Light Leakage

There shall not be visible light from the back-lighting system around the edges of the screen as seen from a distance 50cm from the screen with an overhead light level of 350lux.

11.0 RELIABILITY TEST

The Reliability test items and its conditions are shown in below.

<Table 6. Reliability Test Parameters >

No	Test Items	Conditions	
1	High temperature storage test	Ta = 60 °C, 240 hrs	
2	Low temperature storage test	Ta = -20 °C, 240 hrs	
3	High temperature & high humidity operation test	Ta = 50 °C, 80%RH, 240hrs	
4	High temperature operation test	Ta = 50 °C, 240hrs	
5	Low temperature operation test	Ta = 0°C, 240hrs	
6	Thermal shock	Ta = -20 °C ↔ 60 °C (0.5 hr), 100 cycle	
7	Vibration test (non-operating)	Frequency	Random, 10 ~ 300 Hz, 30 min/Axis
		Gravity / AMP	1.5 Grms
		Period	X, Y, Z 30 min
8	Shock test (non-operating)	Gravity	50G
		Pulse width	11msec, sine wave
		Direction	± X, ± Y, ± Z Once for each
9	Electro-static discharge test (non-operating)	Air : 150 pF, 330Ω, 15 KV	Contact : 150 pF, 330Ω, 8 KV

12.0 HANDLING & CAUTIONS

(1) Cautions when taking out the module

- Pick the pouch only, when taking out module from a shipping package.

(2) Cautions for handling the module

- As the electrostatic discharges may break the LCD module, handle the LCD module with care. Peel a protection sheet off from the LCD panel surface as slowly as possible.
- As the LCD panel and back - light element are made from fragile glass material, impulse and pressure to the LCD module should be avoided.
- As the surface of the polarizer is very soft and easily scratched, use a soft dry cloth without chemicals for cleaning.
- Do not pull the interface connector in or out while the LCD module is operating.
- Put the module display side down on a flat horizontal plane.
- Handle connectors and cables with care.

(3) Cautions for the operation

- When the module is operating, do not lose CLK, ENAB signals. If any one of these signals is lost, the LCD panel would be damaged.
- Obey the supply voltage sequence. If wrong sequence is applied, the module would be damaged.

(4) Cautions for the atmosphere

- Dew drop atmosphere should be avoided.
- Do not store and/or operate the LCD module in a high temperature and/or humidity atmosphere. Storage in an electro-conductive polymer packing pouch and under relatively low temperature atmosphere is recommended.

(5) Cautions for the module characteristics

- Do not apply fixed pattern data signal to the LCD module at product aging.
- Applying fixed pattern for a long time may cause image sticking.

(6) Other cautions

- Do not disassemble and/or re-assemble LCD module.
- Do not re-adjust variable resistor or switch etc.
- When returning the module for repair or etc., Please pack the module not to be broken. We recommend to use the original shipping packages.

BOE

PRODUCT GROUP

REV

ISSUE DATE

TFT- LCD PRODUCT

Rev.0

Mar. 31. 17'

SPEC. NUMBER

SPEC. TITLE

MV238QUM-N20T Preliminary Product Specification Rev.0

PAGE

22 OF30

13.0 PRODUCT SERIAL NUMBER



MV238QUM-N20

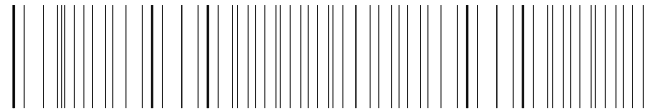

XXXXXXXXXXXXXXXXXXXX

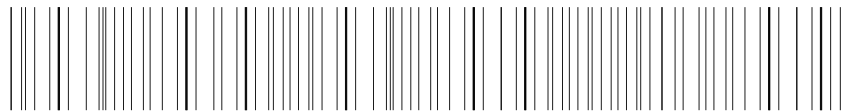

MADE IN CHINA XXXXXXXXXXXXXXXXXXXXXXX



- 1. Control Number
- 2. Rank / Grade
- 3. Line Classification
- 4. Year (2001 : 01, 2002 : 02, ...)
- 5. Month (1,2,3, ... , 9, X, Y, Z)
- 6. Internal Use
- 7. Serial Number

Part Number: MV238QUM-N20T

T T D A 2 3 8 H 3 3 1 Z 1 0 0 0 1

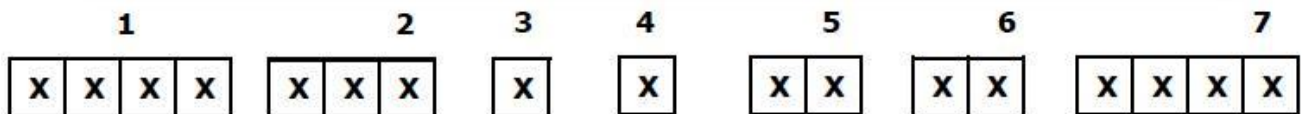

- 1. Manufacturer and Product Type
- 2. Product Size
- 3. Year (2010 -A 2011 -B ...)
- 4. Month (1,2,3, ... , 7,8,9, X, Y, Z)
- 5. Date
- 6. Stage Identification(C1,Z1,D1)
- 7. Serial Number

14.0 Packing

14.1 Packing Order

Put modules into the box

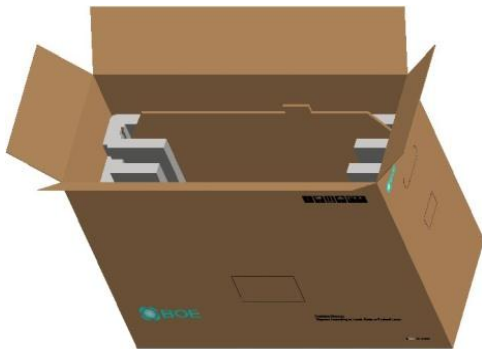

Place the modules bundled by packing bag in the box, 8pcs module per box, place a cover on the top of the box

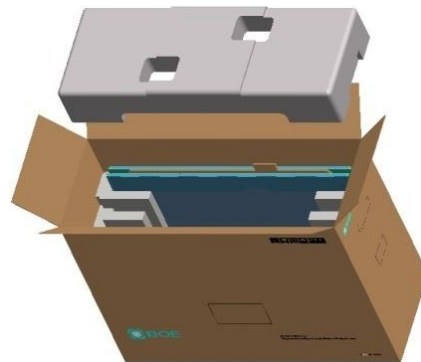

12ea box per pallet

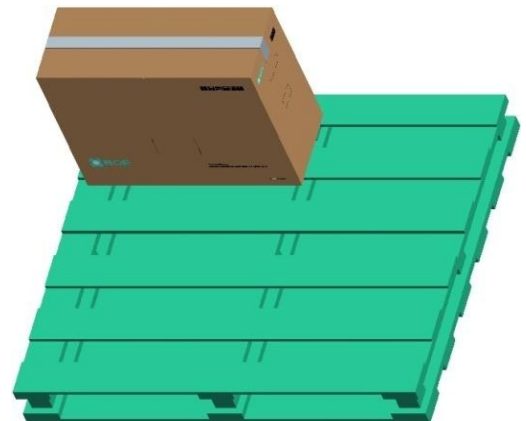

After sealing the box, put the box on the pallet

14.2 Packing Note

- Box Dimension : 235mm(W) × 615mm(L) × 448mm(H)
- Package Quantity in one Box : 8 pcs

14.3 Box label

- Label Size : 110mm (L) × 55 mm (W)
- Contents
Model : MV238QUM-N20
Q'ty : Module 8 Q'ty in one box
Serial No. : Box Serial No. See next page for detail description.
Date : Packing Date

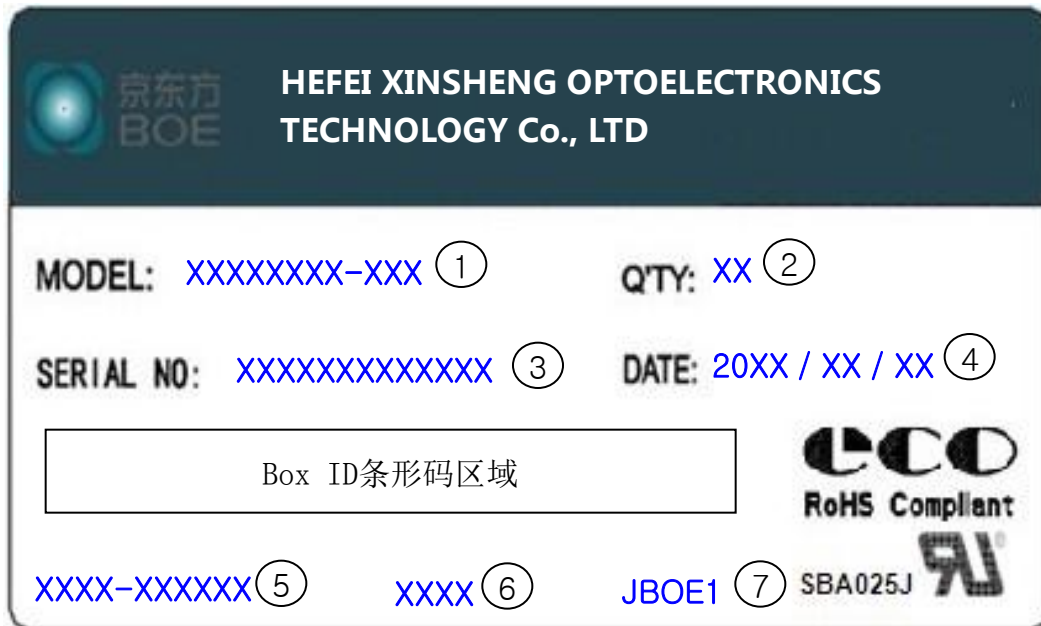

蓝色字体为后打印标识, 说明如下:

1. FG-CODE
2. Box 产品数量
3. Box ID, 编码规则(CIM提供)
4. Box Packing 日期
5. 产品物料号(客户端)(FAE提供)
6. FG-CODE 后四位
7. 供应商代码

14.4 Packing label

- Label Size : 82mm (L) × 38mm (W)
- Contents
Quantity : Packing quantity in one box
Date : Packing Date



15.0 APPENDIX

Figure 1. Measurement Set Up

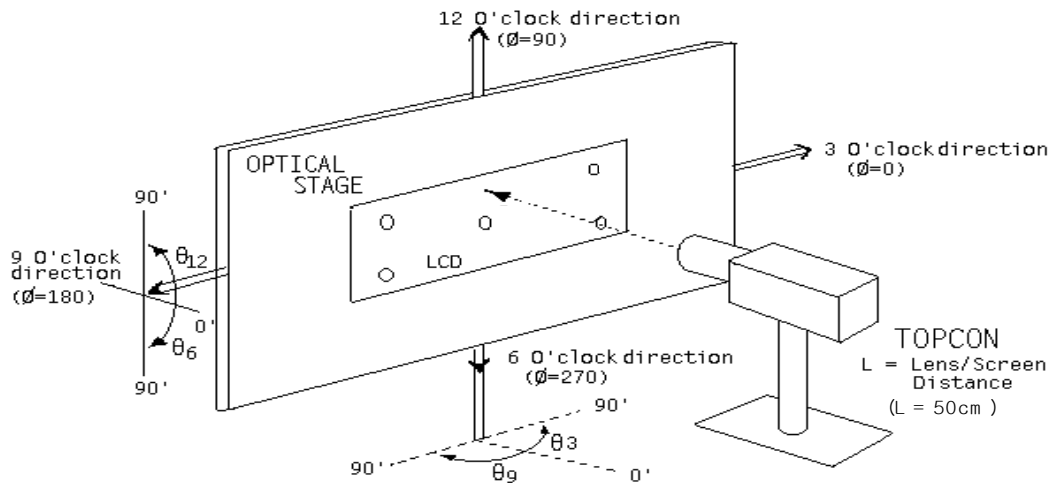

Figure 2. White Luminance and Uniformity Measurement Locations (9 points)

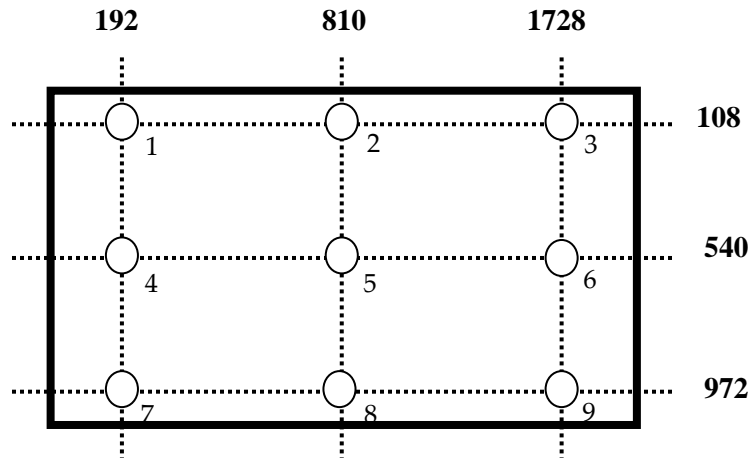
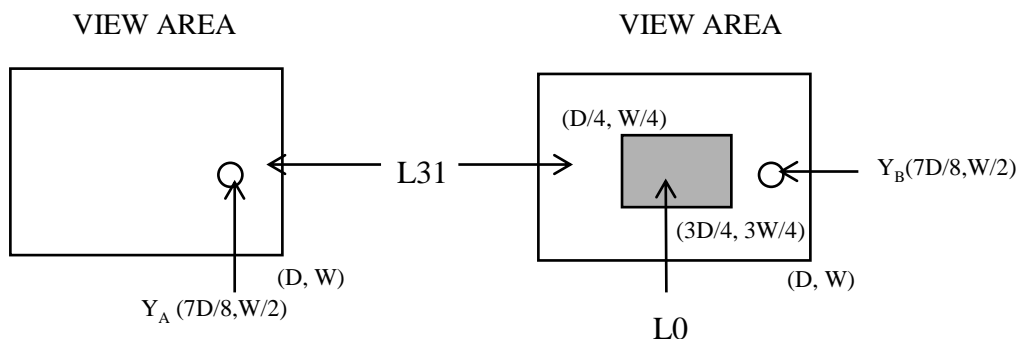

Figure 3. Response Time Testing



Figure 4. Cross Modulation Test Description



$$\text{Cross-Talk (\%)} = \left| \frac{Y_B - Y_A}{Y_A} \right| \times 100$$

Where: Y_A = Initial luminance of measured area (cd/m²)

Y_B = Subsequent luminance of measured area (cd/m²)

The location measured will be exactly the same in both patterns

Figure 5. TFT-LCD Module Outline Dimensions (Front view)

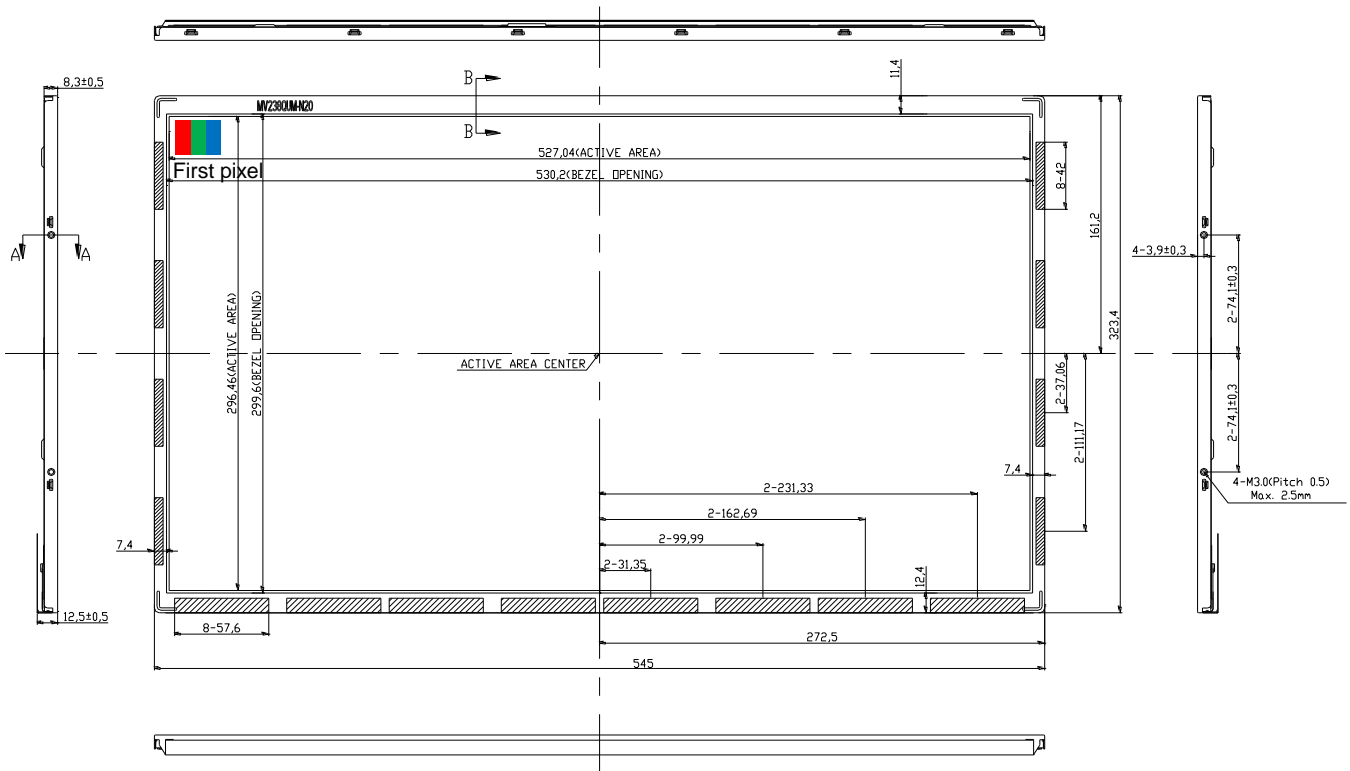

1.7 ≤ Screw Length ≤ 2.5

SECTION A-A
SCALE 5/1

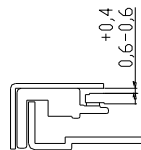

SECTION B-B
SCALE 5/1

NOTE:

1. 1/F CONNECTOR SPECIFICATION
IS050-L30B-C10(UJU)
2. LED CONNECTOR SPECIFICATION
3708K-006N-00L(ENTERY)
3. Torque of userhole: 3.0~4.0kgf-cm.
4. Tilt and partial desposition tolerance of display area as following:
(1) Y-direction: |A-B| ≤ 1.4
(2) X-direction: |C-D| ≤ 1.4



5. Unspecified tolerances to be ±0.5mm.
6. The COF area is weak & sensitive, so don't press the COF area.

Figure 6. TFT-LCD Module Outline Dimensions (Rear view)

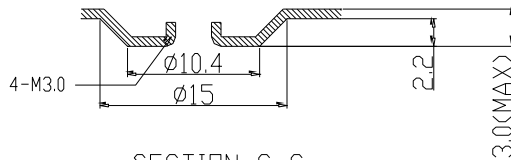
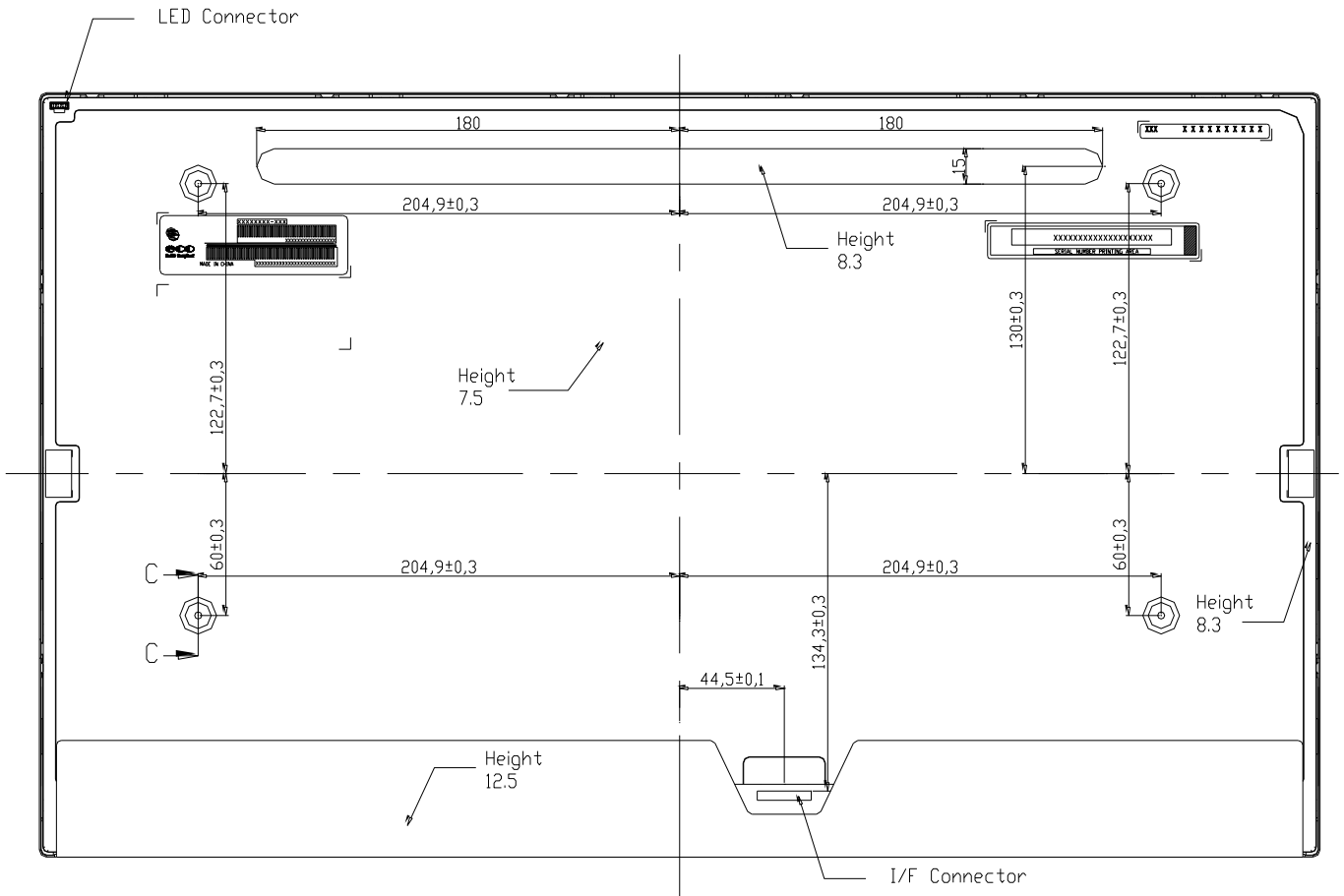

SECTION C-C
SCALE 5/1

Figure 7. Types of adhesive tape

① Source COF protective tape

Material: Black PET
Size: 58 × 29 × 0.1mm

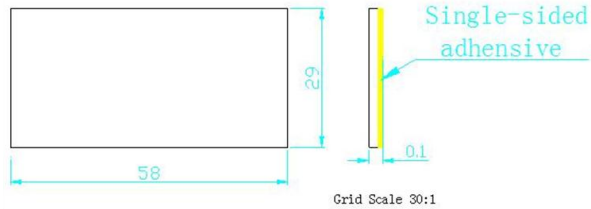

② Gate COF protective tape

Material: Black PET
Size: 43 × 22 × 0.1mm

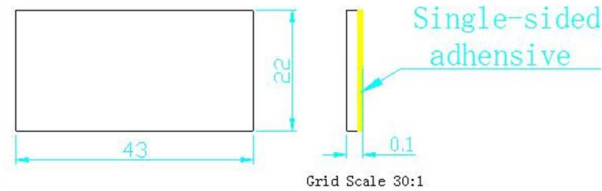

③ OC fixed tape

Material: Black PET
Size: 45 × 16 × 0.1mm

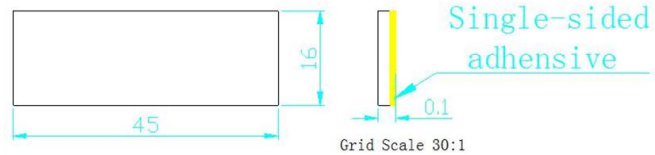

Figure 8. Paste position

