

#### Features

- Wide 2:1 input range
- High efficiency up to 88%
- Extended operating temperature range  
–40°C to +85°C
- Indefinite short circuit protection
- I/O isolation 1500 VDC
- Input filter to meet EN 55022, Class A  
and FCC, level A without external components
- Industry standard footprint
- Shielded metal case with insulated  
baseplate
- 3-year product warranty

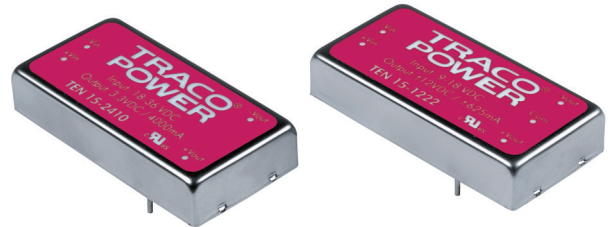

The TEN 15 series is a family of high performance 15W DC/DC converters in a compact 2" x 1" low profile package with industry standard footprint. A high efficiency allows a wide operating temperature range of –40°C to +85°C. A built-in EMI filter is built in to meet EN 55022, class A without any external components.

Further standard features include over voltage protection and short-circuit protection. Typical applications for these converters are battery operated equipment, instrumentation, distributed power architectures in communication and industrial electronics, everywhere where isolated, tightly regulated voltages are required.

#### Models

Order code	Input voltage range	Output voltage	Output current max.	Efficiency typ.
TEN 15-1210	<b>9 – 18 VDC</b> (12 VDC nominal)	3.3 VDC	4'000 mA	79 %
TEN 15-1211		5 VDC	3'000 mA	82 %
TEN 15-1212		12 VDC	1'250 mA	86 %
TEN 15-1213		15 VDC	1'000 mA	86 %
TEN 15-1221		±5 VDC	±1500 mA	83 %
TEN 15-1222		±12 VDC	±625 mA	86 %
TEN 15-1223		±15 VDC	±500 mA	84 %
TEN 15-2410		<b>18 – 36 VDC</b> (24 VDC nominal)	3.3 VDC	4'000 mA
TEN 15-2411	5 VDC		3'000 mA	84 %
TEN 15-2412	12 VDC		1'250 mA	85 %
TEN 15-2413	15 VDC		1'000 mA	85 %
TEN 15-2421	±5 VDC		±1'500 mA	84 %
TEN 15-2422	±12 VDC		±625 mA	86 %
TEN 15-2423	±15 VDC		±500 mA	86 %
TEN 15-4810	<b>36 – 75 VDC</b> (48 VDC nominal)		3.3 VDC	4'000 mA
TEN 15-4811		5 VDC	3'000 mA	83 %
TEN 15-4812		12 VDC	1'250 mA	87 %
TEN 15-4813		15 VDC	1'000 mA	86 %
TEN 15-4821		±5 VDC	±1'500 mA	85 %
TEN 15-4822		±12 VDC	±625 mA	88 %
TEN 15-4823		±15 VDC	±500 mA	87 %

### Input Specifications

Input current at no load	12 Vin models:	<b>30 mA typ.</b>
	24 Vin models:	<b>20 mA typ.</b>
	48 Vin models:	<b>15 mA typ.</b>
Input current at full load	12 Vin; 3.3 VDC models:	<b>1470 mA typ.</b>
	12 Vin; other models:	<b>1550 mA typ.</b>
	24 Vin; 3.3 VDC models:	<b>730 mA typ.</b>
	24 Vin; other models:	<b>780 mA typ.</b>
	48 Vin; 3.3 VDC models:	<b>360 mA typ.</b>
	48 Vin; other models:	<b>380 mA typ.</b>
Surge voltage (100 msec. max.)	12 Vin models:	<b>36 V max.</b>
	24 Vin models:	<b>50 V max.</b>
	48 Vin models:	<b>100 V max.</b>
Conducted noise (input)	<b>EN 55022 level A, FCC part 15, level A</b>	

### Output Specifications

Voltage set accuracy	<b>±1 %</b>	
Regulation	- Input variation Vin min. to Vin max.	<b>0.5 % max.</b>
	- Load variation 2 % – 100 %	single output models: <b>0.5 % max.</b> dual output models: <b>1 % max.</b> (balanced load) <b>5 % max.</b> (load cross variation 25 % / 100 %)
	Minimum load	<b>2 % of rated max. output current.</b> (Operation at lower load is safe but major deviations to specified data may occur)
Ripple and noise (20 MHz Bandwidth)	single output models:	<b>50 mVpk-pk max.</b>
	dual output models:	<b>75 mVpk-pk max.</b>
Temperature coefficient	<b>±0.02 %/K</b>	
Start up time (nominal Vin and constant resistive load)	<b>20 ms typ.</b>	
Transient response (25 % load step change)	<b>250 µs typ.</b>	
Short circuit protection	<b>continuous</b> (automatic recovery)	
Over load protection	<b>150 % of lout max typ. foldback</b>	
Over voltage protection	3.3 VDC models:	<b>3.9 V</b>
	5.0 VDC models:	<b>6.2 V</b>
	12 VDC models:	<b>15 V</b>
	15 VDC models:	<b>18 V</b>
Capacitive load	3.3 VDC models:	<b>10'200 µF max.</b>
	5 VDC models:	<b>7'050 µF max.</b>
	12 VDC models:	<b>1'035 µF max.</b>
	15 VDC models:	<b>750 µF max.</b>
	±5 VDC models:	<b>±1'020 µF max.</b>
	±12 VDC models:	<b>±495 µF max.</b>
	±15 VDC models:	<b>±165 µF max.</b>

All specifications valid at nominal input voltage, full load and +25°C after warm-up time unless otherwise stated.

### General Specifications

<b>Temperature ranges</b>	<ul style="list-style-type: none"> <li>- Operating</li> <li>- Casing temperature</li> <li>- Storage</li> </ul>	<ul style="list-style-type: none"> <li>- 40°C to +85°C</li> <li>+100°C max.</li> <li>-55°C to +105°C</li> </ul>
<b>Derating</b>	3.3 / 5.0 VDC models:	2.5 %/K above 60°C
	other models:	3.3 %/K above 70°C
<b>Thermal impedance</b>	<ul style="list-style-type: none"> <li>- Natural convection</li> <li>- Natural convection with heatsink</li> </ul>	<ul style="list-style-type: none"> <li>12°C/W</li> <li>10°C/W</li> </ul>
<b>Humidity</b> (non condensing)		95 % rel H max.
<b>Reliability, calculated MTBF</b> (MIL-HDBK-217F, at +25°C, ground benign)		>2.3 Mio h
<b>Isolation Test Voltage</b> (Input/Output, 60s)		1'600 VDC
<b>Insulation System</b>		Functional
<b>Isolation Capacitance</b> (Input/Output)		300 pF max.
<b>Isolation Resistance</b> (Input/Output)		>1 G Ohm
<b>Switching frequency</b>	<ul style="list-style-type: none"> <li>single output models:</li> <li>dual output models:</li> </ul>	<ul style="list-style-type: none"> <li>500 kHz typ. (pulse width modulation)</li> <li>300 kHz typ. (pulse width modulation)</li> </ul>
<b>EMC immunity</b>	<ul style="list-style-type: none"> <li>- Electrostatic discharge ESD</li> <li>- RF field susceptibility</li> <li>- Electrical fast transient / burst immunity input</li> <li>- Surge immunity</li> <li>- Immunity to conducted RF disturbances</li> </ul>	<ul style="list-style-type: none"> <li>EN 61000-4-2    8 kV / 6 kV, criteria B</li> <li>EN 61000-4-3    10 V/m, criteria A</li> <li>EN 61000-4-4    ±2 kV, criteria B</li> <li>EN 61000-4-5    ±1 kV, criteria B</li> <li>EN 61000-4-6    10 Vrms, criteria A</li> </ul>
<b>Vibration</b>		acc. MIL-STD-810F
<b>Thermal shock</b>		acc. MIL-STD-810F
<b>Safety standards</b>		UL 60950-1, EN 60950-1, IEC 60950-1 UL 62368-1
<b>Safety approvals</b>	- UL/cUL	<a href="http://www.ul.com">www.ul.com</a> -> certifications -> File e188913
<b>Environmental compliance</b>	<ul style="list-style-type: none"> <li>- Reach</li> <li>- RoHS</li> </ul>	<a href="http://www.tracopower.com/info/reach-declaration.pdf">www.tracopower.com/info/reach-declaration.pdf</a> RoHS directive 2011/65/EU

### Physical Specifications

<b>Casing material</b>	copper, nickel plated
<b>Baseplate material</b>	non conductive FR4
<b>Potting material</b>	epoxy (UL 94V-0 rated)
<b>Weight</b>	27 g (09.5oz)
<b>Soldering temperature</b>	max. +265°C / 10 sec.

**Supporting documents :** [www.tracopower.com/overview/ten15](http://www.tracopower.com/overview/ten15)

All specifications valid at nominal input voltage, full load and +25°C after warm-up time unless otherwise stated.

**Outline Dimensions**

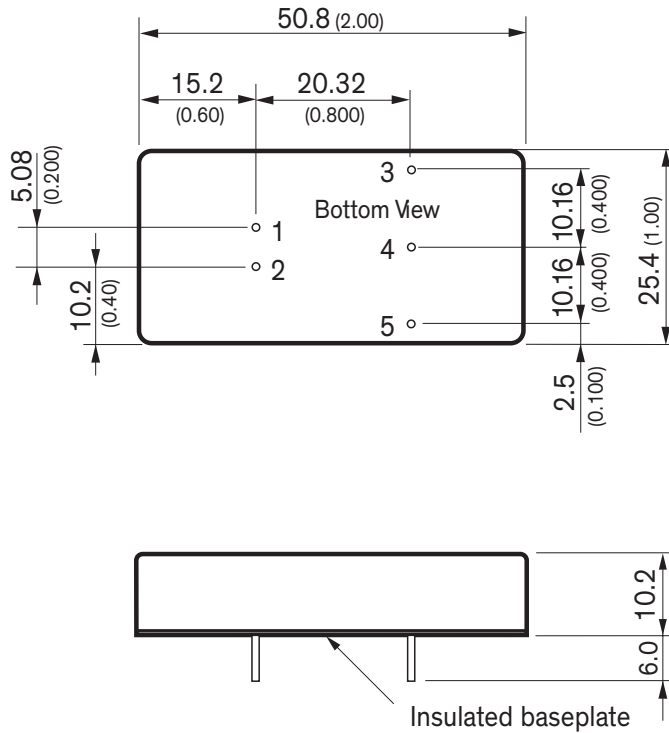

Pin-Out		
Pin	Single	Dual
1	+Vin (Vcc)	+Vin (Vcc)
2	-Vin (GND)	-Vin (GND)
3	+Vout	+Vout
4	No pin	Common
5	-Vout	-Vout

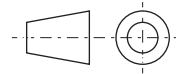

Dimensions in [mm], ( ) = Inch  
 Pin diameter: 1.0 ±0.05 (0.02 ±0.002)  
 Pin pitch tolerances: ±0.25 (±0.01)  
 Casing tolerances: ±0.5 (±0.02)

**Heat-Sink (Option)**

**Order code:** TEN-HS1

(cont.: heat-sink, thermal pad, 2 clamps)

**Material:** Aluminum

**Finish:** Anodic treatment (black)

**Weight:** 17g (0.60oz) without converter

Thermal impedance after assembling: 10 K/W



**Note:**

The product label on converter has to be removed before mounting the heat-sink.

For volume orders converters will be supplied with heat-sinks already mounted. Please contact factory for quotation.

Separate heat-sinks are only available for prototypes and small quantity orders.

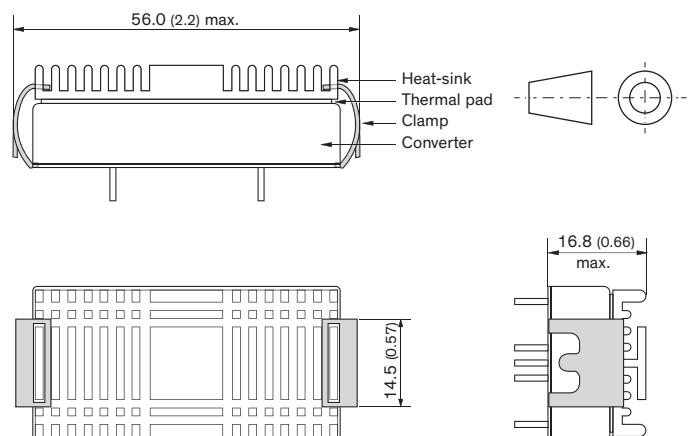

Specifications can be changed without notice! Make sure you are using the latest documentation, downloadable at [www.tracopower.com](http://www.tracopower.com)