



Product Specification

AU OPTRONICS CORPORATION

Contents

1. Handling Precautions	5
2. General Description	6
2.1 General Specification	6
2.2 Optical Characteristics	7
3. Functional Block Diagram	11
4. Absolute Maximum Ratings.....	12
4.1 Absolute Ratings of TFT LCD Module	12
4.2 Absolute Ratings of Environment	12
5. Electrical Characteristics.....	13
5.1 TFT LCD Module.....	13
5.2 Backlight Unit	20
6. Signal Interface Characteristic.....	21
6.1 Pixel Format Image	21
6.2 Integration Interface Requirement	21
6.3 Interface Timing	23
6.4 Power On Sequence.....	24
7. Panel Reliability Test	25
7.1 Vibration Test	25
7.2 Shock Test	25
7.3 Reliability Test.....	25
8. Mechanical Characteristics.....	27
9. Shipping and Package	28
9.1 Shipping Label Format	28
9.2 Carton Package.....	28
9.3 Shipping Package of Palletizing Sequence.....	29

Product Specification

AU OPTRONICS CORPORATION

Record of Revision

Version and Date	Page	Old description	New Description	Remark																																																																																												
0.1 2020/9/2	All	First Edition																																																																																														
0.2 2020/9/7	27																																																																																															
0.3 2020/9/15	6	<table border="1"> <tr> <td rowspan="12">Color / Chromaticity Coordinates</td> <td>Red</td> <td>Rx</td> <td>TBD.</td> <td>TBD.</td> <td>TBD.</td> </tr> <tr> <td></td> <td>Ry</td> <td>TBD.</td> <td>TBD.</td> <td>TBD.</td> </tr> <tr> <td>Green</td> <td>Gx</td> <td>TBD.</td> <td>TBD.</td> <td>TBD.</td> </tr> <tr> <td></td> <td>Gy</td> <td>TBD.</td> <td>TBD.</td> <td>TBD.</td> </tr> <tr> <td>Blue</td> <td>Bx</td> <td>TBD.</td> <td>TBD.</td> <td>TBD.</td> </tr> <tr> <td></td> <td>By</td> <td>TBD.</td> <td>TBD.</td> <td>TBD.</td> </tr> <tr> <td>White</td> <td>Wx</td> <td>0.250</td> <td>0.300</td> <td>0.350</td> </tr> <tr> <td></td> <td>Wy</td> <td>0.270</td> <td>0.320</td> <td>0.370</td> </tr> <tr> <td colspan="3">CIE 1931</td> <td></td> <td></td> </tr> </table>	Color / Chromaticity Coordinates	Red	Rx	TBD.	TBD.	TBD.		Ry	TBD.	TBD.	TBD.	Green	Gx	TBD.	TBD.	TBD.		Gy	TBD.	TBD.	TBD.	Blue	Bx	TBD.	TBD.	TBD.		By	TBD.	TBD.	TBD.	White	Wx	0.250	0.300	0.350		Wy	0.270	0.320	0.370	CIE 1931					<table border="1"> <tr> <td rowspan="12">Color / Chromaticity Coordinates</td> <td>Red</td> <td>Rx</td> <td>TBD.</td> <td>TBD.</td> <td>TBD.</td> </tr> <tr> <td></td> <td>Ry</td> <td>TBD.</td> <td>TBD.</td> <td>TBD.</td> </tr> <tr> <td>Green</td> <td>Gx</td> <td>TBD.</td> <td>TBD.</td> <td>TBD.</td> </tr> <tr> <td></td> <td>Gy</td> <td>TBD.</td> <td>TBD.</td> <td>TBD.</td> </tr> <tr> <td>Blue</td> <td>Bx</td> <td>TBD.</td> <td>TBD.</td> <td>TBD.</td> </tr> <tr> <td></td> <td>By</td> <td>TBD.</td> <td>TBD.</td> <td>TBD.</td> </tr> <tr> <td>White</td> <td>Wx</td> <td>0.270</td> <td>0.300</td> <td>0.330</td> </tr> <tr> <td></td> <td>Wy</td> <td>0.300</td> <td>0.330</td> <td>0.360</td> </tr> <tr> <td colspan="3">CIE 1931</td> <td></td> <td></td> </tr> </table>	Color / Chromaticity Coordinates	Red	Rx	TBD.	TBD.	TBD.		Ry	TBD.	TBD.	TBD.	Green	Gx	TBD.	TBD.	TBD.		Gy	TBD.	TBD.	TBD.	Blue	Bx	TBD.	TBD.	TBD.		By	TBD.	TBD.	TBD.	White	Wx	0.270	0.300	0.330		Wy	0.300	0.330	0.360	CIE 1931					
Color / Chromaticity Coordinates	Red	Rx		TBD.	TBD.	TBD.																																																																																										
		Ry		TBD.	TBD.	TBD.																																																																																										
	Green	Gx		TBD.	TBD.	TBD.																																																																																										
		Gy		TBD.	TBD.	TBD.																																																																																										
	Blue	Bx		TBD.	TBD.	TBD.																																																																																										
		By		TBD.	TBD.	TBD.																																																																																										
	White	Wx		0.250	0.300	0.350																																																																																										
		Wy		0.270	0.320	0.370																																																																																										
	CIE 1931																																																																																															
	Color / Chromaticity Coordinates	Red		Rx	TBD.	TBD.	TBD.																																																																																									
				Ry	TBD.	TBD.	TBD.																																																																																									
		Green	Gx	TBD.	TBD.	TBD.																																																																																										
		Gy	TBD.	TBD.	TBD.																																																																																											
Blue		Bx	TBD.	TBD.	TBD.																																																																																											
		By	TBD.	TBD.	TBD.																																																																																											
White		Wx	0.270	0.300	0.330																																																																																											
		Wy	0.300	0.330	0.360																																																																																											
CIE 1931																																																																																																
		5	<table border="1"> <tr> <td>Physical Size</td> <td>[mm]</td> <td>Min.</td> <td>Typ.</td> <td>Max.</td> </tr> <tr> <td>Length</td> <td></td> <td>114.4</td> <td>114.6</td> <td>114.8</td> </tr> <tr> <td>Width</td> <td></td> <td>183.925</td> <td>184.125</td> <td>184.325</td> </tr> <tr> <td>Thickness</td> <td></td> <td>-</td> <td>-</td> <td>3.95</td> </tr> </table>	Physical Size	[mm]	Min.	Typ.	Max.	Length		114.4	114.6	114.8	Width		183.925	184.125	184.325	Thickness		-	-	3.95	<table border="1"> <tr> <td>Physical Size</td> <td>[mm]</td> <td>Min.</td> <td>Typ.</td> <td>Max.</td> </tr> <tr> <td>Length</td> <td></td> <td>114.4</td> <td>114.6</td> <td>114.8</td> </tr> <tr> <td>Width</td> <td></td> <td>183.925</td> <td>184.125</td> <td>184.325</td> </tr> <tr> <td>Thickness</td> <td></td> <td>-</td> <td>-</td> <td>4.27</td> </tr> </table>	Physical Size	[mm]	Min.	Typ.	Max.	Length		114.4	114.6	114.8	Width		183.925	184.125	184.325	Thickness		-	-	4.27																																																				
Physical Size		[mm]	Min.	Typ.	Max.																																																																																											
Length			114.4	114.6	114.8																																																																																											
Width		183.925	184.125	184.325																																																																																												
Thickness		-	-	3.95																																																																																												
Physical Size	[mm]	Min.	Typ.	Max.																																																																																												
Length		114.4	114.6	114.8																																																																																												
Width		183.925	184.125	184.325																																																																																												
Thickness		-	-	4.27																																																																																												
	27																																																																																															
0.4 2020/9/18		<table border="1"> <tr> <td>Physical Size</td> <td>[mm]</td> <td>Min.</td> <td>Typ.</td> <td>Max.</td> </tr> <tr> <td>Length</td> <td></td> <td>114.4</td> <td>114.6</td> <td>114.8</td> </tr> <tr> <td>Width</td> <td></td> <td>183.925</td> <td>184.125</td> <td>184.325</td> </tr> <tr> <td>Thickness</td> <td></td> <td>-</td> <td>-</td> <td>4.27</td> </tr> </table>	Physical Size	[mm]	Min.	Typ.	Max.	Length		114.4	114.6	114.8	Width		183.925	184.125	184.325	Thickness		-	-	4.27	<table border="1"> <tr> <td>Physical Size</td> <td>[mm]</td> <td>Min.</td> <td>Typ.</td> <td>Max.</td> </tr> <tr> <td>Length</td> <td></td> <td>114.4</td> <td>114.6</td> <td>114.8</td> </tr> <tr> <td>Width</td> <td></td> <td>183.925</td> <td>184.125</td> <td>184.325</td> </tr> <tr> <td>Thickness</td> <td></td> <td>-</td> <td>-</td> <td>3.95</td> </tr> </table>	Physical Size	[mm]	Min.	Typ.	Max.	Length		114.4	114.6	114.8	Width		183.925	184.125	184.325	Thickness		-	-	3.95																																																					
Physical Size	[mm]	Min.	Typ.	Max.																																																																																												
Length		114.4	114.6	114.8																																																																																												
Width		183.925	184.125	184.325																																																																																												
Thickness		-	-	4.27																																																																																												
Physical Size	[mm]	Min.	Typ.	Max.																																																																																												
Length		114.4	114.6	114.8																																																																																												
Width		183.925	184.125	184.325																																																																																												
Thickness		-	-	3.95																																																																																												

Product Specification

AU OPTRONICS CORPORATION

		<table border="1"> <tr> <td colspan="2">MPI connector:-</td> <td></td> </tr> <tr> <td>Connector Name / Designation-</td> <td colspan="2">For Signal Connector-</td> </tr> <tr> <td>Manufacturer:-</td> <td colspan="2">Panasonic-</td> </tr> <tr> <td>Type / Part Number:-</td> <td colspan="2">AYF424035 or compatible-</td> </tr> <tr> <td>Mating Housing/Part Number-</td> <td colspan="2">FPC-</td> </tr> </table>	MPI connector:-			Connector Name / Designation-	For Signal Connector-		Manufacturer:-	Panasonic-		Type / Part Number:-	AYF424035 or compatible-		Mating Housing/Part Number-	FPC-		<table border="1"> <tr> <td colspan="2">MPI connector:-</td> <td></td> </tr> <tr> <td>Connector Name / Designation-</td> <td colspan="2">For Signal Connector-</td> </tr> <tr> <td>Manufacturer:-</td> <td colspan="2">HRS-</td> </tr> <tr> <td>Type / Part Number:-</td> <td colspan="2">FH34SRJ-40S-0.5SH or compatible-</td> </tr> <tr> <td>Mating Housing/Part Number-</td> <td colspan="2">FPC-</td> </tr> </table>	MPI connector:-			Connector Name / Designation-	For Signal Connector-		Manufacturer:-	HRS-		Type / Part Number:-	FH34SRJ-40S-0.5SH or compatible-		Mating Housing/Part Number-	FPC-																																																			
MPI connector:-																																																																																			
Connector Name / Designation-	For Signal Connector-																																																																																		
Manufacturer:-	Panasonic-																																																																																		
Type / Part Number:-	AYF424035 or compatible-																																																																																		
Mating Housing/Part Number-	FPC-																																																																																		
MPI connector:-																																																																																			
Connector Name / Designation-	For Signal Connector-																																																																																		
Manufacturer:-	HRS-																																																																																		
Type / Part Number:-	FH34SRJ-40S-0.5SH or compatible-																																																																																		
Mating Housing/Part Number-	FPC-																																																																																		
0.5	2020/11/04	6	<table border="1"> <tr> <td>Glass Thickness-</td> <td>[mm]</td> <td>0.2</td> </tr> <tr> <td>Surface Treatment (panel only)-</td> <td></td> <td>Glare-</td> </tr> <tr> <td>Support Color-</td> <td></td> <td>RGB 8-bit-</td> </tr> <tr> <td>Temperature Range-</td> <td>[°C]</td> <td>-10 to +60-</td> </tr> <tr> <td>Operating Storage (Non-Operating)-</td> <td>[°C]</td> <td>-20 to +70-</td> </tr> <tr> <td>RoHS Compliance-</td> <td></td> <td>RoHS Compliance-</td> </tr> </table>	Glass Thickness-	[mm]	0.2	Surface Treatment (panel only)-		Glare-	Support Color-		RGB 8-bit-	Temperature Range-	[°C]	-10 to +60-	Operating Storage (Non-Operating)-	[°C]	-20 to +70-	RoHS Compliance-		RoHS Compliance-	<table border="1"> <tr> <td>Electrical Interface-</td> <td></td> <td>4 lane MIPI-</td> </tr> <tr> <td>Glass Thickness-</td> <td>[mm]</td> <td>0.2-</td> </tr> <tr> <td>Surface Treatment (panel only)-</td> <td></td> <td>Glare-</td> </tr> <tr> <td>Support Color-</td> <td></td> <td>RGB 8-bit-</td> </tr> <tr> <td>Temperature Range-</td> <td>[°C]</td> <td>-10 to +60-</td> </tr> <tr> <td>Operating Storage (Non-Operating)-</td> <td>[°C]</td> <td>-20 to +70-</td> </tr> <tr> <td>RoHS Compliance-</td> <td></td> <td>RoHS Compliance-</td> </tr> <tr> <td>S-IC Information-</td> <td></td> <td>HX82790 (Dfvc - 0x6)</td> </tr> </table>	Electrical Interface-		4 lane MIPI-	Glass Thickness-	[mm]	0.2-	Surface Treatment (panel only)-		Glare-	Support Color-		RGB 8-bit-	Temperature Range-	[°C]	-10 to +60-	Operating Storage (Non-Operating)-	[°C]	-20 to +70-	RoHS Compliance-		RoHS Compliance-	S-IC Information-		HX82790 (Dfvc - 0x6)																																					
Glass Thickness-	[mm]	0.2																																																																																	
Surface Treatment (panel only)-		Glare-																																																																																	
Support Color-		RGB 8-bit-																																																																																	
Temperature Range-	[°C]	-10 to +60-																																																																																	
Operating Storage (Non-Operating)-	[°C]	-20 to +70-																																																																																	
RoHS Compliance-		RoHS Compliance-																																																																																	
Electrical Interface-		4 lane MIPI-																																																																																	
Glass Thickness-	[mm]	0.2-																																																																																	
Surface Treatment (panel only)-		Glare-																																																																																	
Support Color-		RGB 8-bit-																																																																																	
Temperature Range-	[°C]	-10 to +60-																																																																																	
Operating Storage (Non-Operating)-	[°C]	-20 to +70-																																																																																	
RoHS Compliance-		RoHS Compliance-																																																																																	
S-IC Information-		HX82790 (Dfvc - 0x6)																																																																																	
		23	<table border="1"> <tr><td>1.</td><td>LED+</td><td>Anode for light bar.</td></tr> <tr><td>2.</td><td>LED+</td><td>Anode for light bar.</td></tr> <tr><td>3.</td><td>NC.</td><td>No connection.</td></tr> <tr><td>4.</td><td>LED1-</td><td>Cathode for light bar.</td></tr> <tr><td>5.</td><td>LED2-</td><td>Cathode for light bar.</td></tr> <tr><td>6.</td><td>LED3-</td><td>Cathode for light bar.</td></tr> <tr><td>7.</td><td>NC.</td><td>No connection.</td></tr> <tr><td>8.</td><td>NC.</td><td>No connection.</td></tr> <tr><td>9.</td><td>NC.</td><td>No connection.</td></tr> <tr><td>10.</td><td>NC.</td><td>No connection.</td></tr> <tr><td>11.</td><td>NC.</td><td>No connection.</td></tr> <tr><td>12.</td><td>NC.</td><td>No connection.</td></tr> <tr><td>13.</td><td>ID.</td><td>floating.</td></tr> </table>	1.	LED+	Anode for light bar.	2.	LED+	Anode for light bar.	3.	NC.	No connection.	4.	LED1-	Cathode for light bar.	5.	LED2-	Cathode for light bar.	6.	LED3-	Cathode for light bar.	7.	NC.	No connection.	8.	NC.	No connection.	9.	NC.	No connection.	10.	NC.	No connection.	11.	NC.	No connection.	12.	NC.	No connection.	13.	ID.	floating.	<table border="1"> <tr><td>1.</td><td>LED+</td><td>Anode for light bar.</td></tr> <tr><td>2.</td><td>LED+</td><td>Anode for light bar.</td></tr> <tr><td>3.</td><td>NC.</td><td>No connection.</td></tr> <tr><td>4.</td><td>LED1-</td><td>Cathode for light bar.</td></tr> <tr><td>5.</td><td>LED2-</td><td>Cathode for light bar.</td></tr> <tr><td>6.</td><td>LED3-</td><td>Cathode for light bar.</td></tr> <tr><td>7.</td><td>NC.</td><td>No connection.</td></tr> <tr><td>8.</td><td>NC.</td><td>No connection.</td></tr> <tr><td>9.</td><td>NC.</td><td>No connection.</td></tr> <tr><td>10.</td><td>NC.</td><td>No connection.</td></tr> <tr><td>11.</td><td>NC.</td><td>No connection.</td></tr> <tr><td>12.</td><td>NC.</td><td>No connection.</td></tr> <tr><td>13.</td><td>ID.</td><td>High.</td></tr> </table>	1.	LED+	Anode for light bar.	2.	LED+	Anode for light bar.	3.	NC.	No connection.	4.	LED1-	Cathode for light bar.	5.	LED2-	Cathode for light bar.	6.	LED3-	Cathode for light bar.	7.	NC.	No connection.	8.	NC.	No connection.	9.	NC.	No connection.	10.	NC.	No connection.	11.	NC.	No connection.	12.	NC.	No connection.	13.	ID.	High.	
1.	LED+	Anode for light bar.																																																																																	
2.	LED+	Anode for light bar.																																																																																	
3.	NC.	No connection.																																																																																	
4.	LED1-	Cathode for light bar.																																																																																	
5.	LED2-	Cathode for light bar.																																																																																	
6.	LED3-	Cathode for light bar.																																																																																	
7.	NC.	No connection.																																																																																	
8.	NC.	No connection.																																																																																	
9.	NC.	No connection.																																																																																	
10.	NC.	No connection.																																																																																	
11.	NC.	No connection.																																																																																	
12.	NC.	No connection.																																																																																	
13.	ID.	floating.																																																																																	
1.	LED+	Anode for light bar.																																																																																	
2.	LED+	Anode for light bar.																																																																																	
3.	NC.	No connection.																																																																																	
4.	LED1-	Cathode for light bar.																																																																																	
5.	LED2-	Cathode for light bar.																																																																																	
6.	LED3-	Cathode for light bar.																																																																																	
7.	NC.	No connection.																																																																																	
8.	NC.	No connection.																																																																																	
9.	NC.	No connection.																																																																																	
10.	NC.	No connection.																																																																																	
11.	NC.	No connection.																																																																																	
12.	NC.	No connection.																																																																																	
13.	ID.	High.																																																																																	
0.6	2021/03/04	06	TBD	Add weight 70.4g +-10%																																																																															
		07	white liminance min 340/max 400	a. Updated white liminance min 400/max 440 b.add R/G/B color cordinales																																																																															
		20	TBD	Add LEDs arrangement of light bar																																																																															
		28/29	TBD	Add Shipping and Package																																																																															
1.0	2021/05/25	06	-	Modify White Luminance 460 (typ.)																																																																															
		07	-	Add Flicker SPEC -20dB																																																																															



Product Specification

AU OPTRONICS CORPORATION

1. Handling Precautions

- 1) Since front polarizer is easily damaged, pay attention not to scratch it.
- 2) Be sure to turn off power supply when inserting or disconnecting from input connector.
- 3) Wipe off water drop immediately. Long contact with water may cause discoloration or spots.
- 4) When the panel surface is soiled, wipe it with absorbent cotton or other soft cloth.
- 5) Since the panel is made of glass, it may break or crack if dropped or bumped on hard surface.
- 6) Since CMOS LSI is used in this module, take care of static electricity and insure human earth when handling.
- 7) Do not open nor modify the Module Assembly.
- 8) Do not press the reflector sheet at the back of the module to any directions.
- 9) At the insertion or removal of the Signal Interface Connector, be sure not to rotate nor tilt the Interface Connector of the TFT Module.
- 11) After installation of the TFT Module into an enclosure (Notebook PC Bezel, for example), do not twist nor bend the TFT Module even momentarily. At designing the enclosure, it should be taken into consideration that no bending/twisting forces are applied to the TFT Module from outside. Otherwise the TFT Module may be damaged.
- 12) Small amount of materials having no flammability grade is used in the LCD module. The LCD module should be supplied by power complied with requirements of Limited Power Source (IEC60950 or UL1950), or be applied exemption.
- 13) Disconnecting power supply before handling LCD modules, it can prevent electric shock, DO NOT TOUCH the electrode parts, cables, connectors and LED circuit part of TFT module that a LED light bar build in as a light source of back light unit. It can prevent electrostatic breakdown.



Product Specification

AU OPTRONICS CORPORATION

2. General Description

G080UAN0x.x is a Color Active Matrix Liquid Crystal Display composed of a TFT LCD panel, a driver circuit, and LED backlight system. The screen format is intended to support the 16:10 , 1200(H) x1920(V) screen and 16.7M colors (RGB 8-bits data driver) without LED backlight driving circuit. All input signals are MIPI interface compatible.

G080UAN02.2 is designed for a display unit of notebook style personal computer and industrial machine.

2.1 General Specification

The following items are characteristics summary on the table at 25 °C condition:

Items	Unit	Specifications			
Screen Diagonal	[mm]	203.09 (8")			
Active Area	[mm]	107.64(H) x 172.224(V)			
Pixels H x V		1200 x 3(RGB) x 1920			
Pixel Pitch	[mm]	0.0897 x 0.0897			
Pixel Format		R.G.B. Vertical Stripe			
Display Mode		Normally Black			
White Luminance (ILED= 23 mA) (Note: ILED is LED current)	[cd/m ²]	460(typ.)			
Luminance Uniformity		80%(MIN)			
Contrast Ratio		900:1 (Typ.)			
Response Time	[ms]	Tr + Tf : 25 (Typ.)			
Nominal Input Voltage VDD	[Volt]	+3.3 V typ			
Power Consumption	[Watt]	LCD 0.5W Max. BLU 1.4W Max.			
Weight	[Grams]	70.4+10%			
Physical Size	[mm]		Min.	Typ.	Max.
		Length	114.4	114.6	114.8
		Width	183.925	184.125	184.325
		Thickness			3.95
Electrical Interface		4 lane MIPI			
Glass Thickness	[mm]	0.2			
Surface Treatment(panel only)		Glare			
Support Color		RGB 8-bit			
Temperature Range Operating Storage (Non-Operating)	[°C] [°C]	-10 to +60 -20 to +70			
RoHS Compliance		RoHS Compliance			
S-IC Information		HX8279(vendor id : 0x82790D (0xfc – 0xfe)			

Product Specification

AU OPTRONICS CORPORATION

2.2 Optical Characteristics

The optical characteristics are measured under stable conditions at 25°C (Room Temperature) :

Item	Symbol	Conditions	Min.	Typ.	Max.	Unit	Note
White Luminance		5 points average	380	460		cd/m ²	1, 4, 5.
Viewing Angle	θ_R θ_L	Horizontal (Right) CR = 10 (Left)		85		degree	4, 9
	ψ_H ψ_L	Vertical (Upper) CR = 10 (Lower)		85			
Luminance Uniformity	δ_{5P}	5 Points	80%	85%			1, 3, 4
Contrast Ratio	CR			900			4, 6
Cross talk	%				4		4, 7
Flicker					-20	dB	
Response Time	T_{RT}	Rising + Falling		25	35	msec	4, 8
Color / Chromaticity Coordinates	Red	Rx	CIE 1931	0.6054	0.6354	0.6654	4
		Ry		0.2924	0.3224	0.3524	
	Green	Gx		0.2431	0.2731	0.3031	
		Gy		0.6376	0.6676	0.6976	
	Blue	Bx		0.1201	0.1501	0.1801	
		By		0.0921	0.1221	0.1521	
	White	Wx		0.270	0.300	0.330	
		Wy		0.300	0.330	0.360	
NTSC	%			72			

Note 1: 5 points position (Ref: Active area)

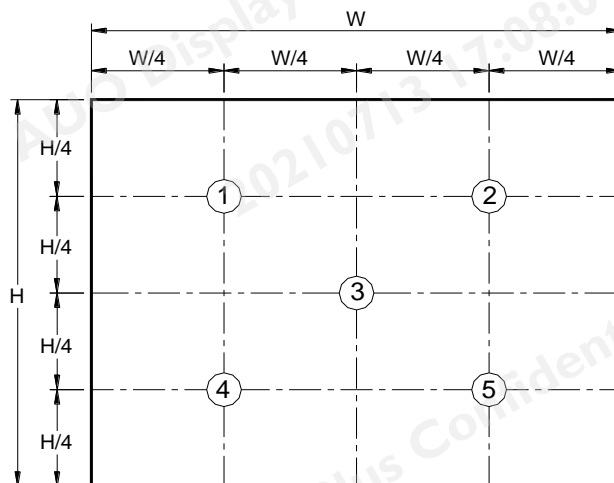



Product Specification

AU OPTRONICS CORPORATION

Note 3: The luminance uniformity of 5 points is defined by dividing the maximum luminance values by the minimum test point luminance

$$\delta_{W5} = \frac{\text{Minimum Brightness of five points}}{\text{Maximum Brightness of five points}}$$

$$\delta_{W13} = \frac{\text{Minimum Brightness of thirteen points}}{\text{Maximum Brightness of thirteen points}}$$

Note 4: Measurement method

The LCD module should be stabilized at given temperature for 30 minutes to avoid abrupt temperature change during measuring. In order to stabilize the luminance, the measurement should be executed after lighting Backlight for 30 minutes in a stable, windless and dark room, and it should be measured in the center of screen.

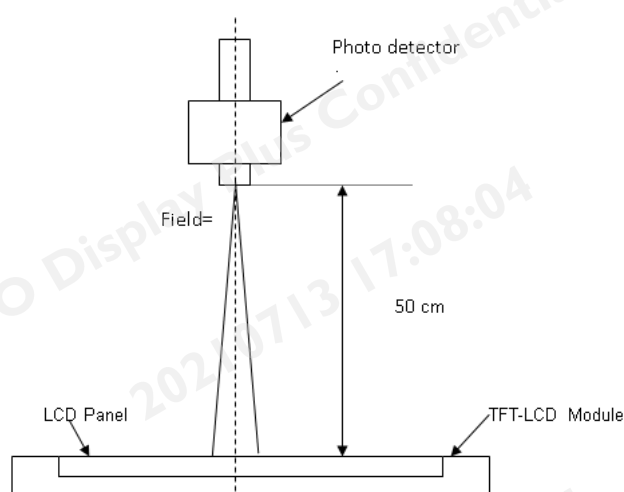

Note 5: Definition of Average Luminance of White (Y_L):

Measure the luminance of gray level 63 at 5 points , $Y_L = [L (1)+ L (2)+ L (3)+ L (4)+ L (5)] / 5$

$L (x)$ is corresponding to the luminance of the point X at Figure in Note (1).

Note 6: Definition of contrast ratio:

Contrast ratio is calculated with the following formula.

$$\text{Contrast ratio (CR)} = \frac{\text{Brightness on the "White" state}}{\text{Brightness on the "Black" state}}$$

Note 7: Definition of Cross Talk (CT)

$$CT = | Y_B - Y_A | / Y_A \times 100 (\%)$$

Where

Y_A = Luminance of measured location without gray level 0 pattern (cd/m²)

Y_B = Luminance of measured location with gray level 0 pattern (cd/m²)

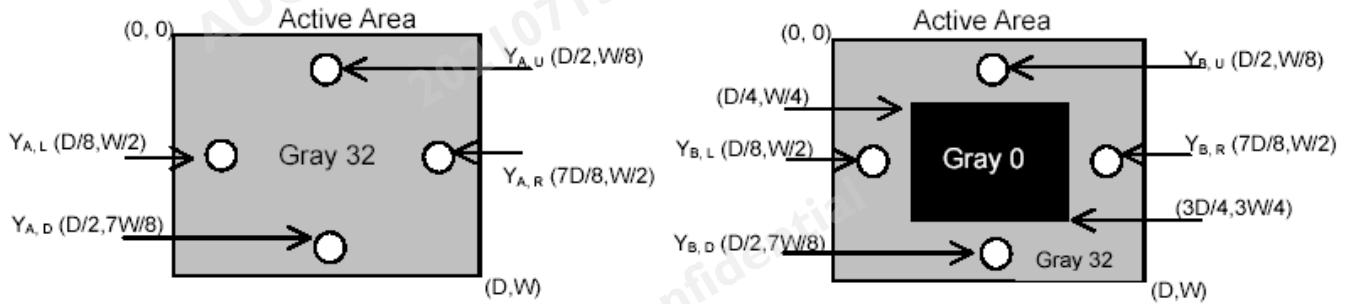

Note 8: Definition of response time:

The output signals of BM-7 or equivalent are measured when the input signals are changed from "Black" to "White" (falling time) and from "White" to "Black" (rising time), respectively. The response time interval between the 10% and 90% of amplitudes. Refer to figure as below.

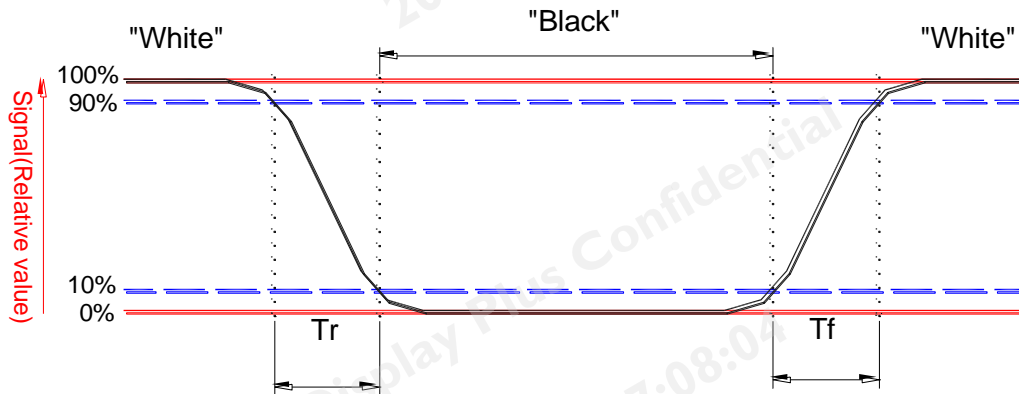

Product Specification

AU OPTRONICS CORPORATION

Note 9: Definition of viewing angle

Viewing angle is the measurement of contrast ratio ≥ 10 , at the screen center, over a 180° horizontal and 180° vertical range (off-normal viewing angles). The 180° viewing angle range is broken down as follows; 90° (θ) horizontal left and right and 90° (Φ) vertical, high (up) and low (down). The measurement direction is typically perpendicular to the display surface with the screen rotated about its center to develop the desired measurement viewing angle.

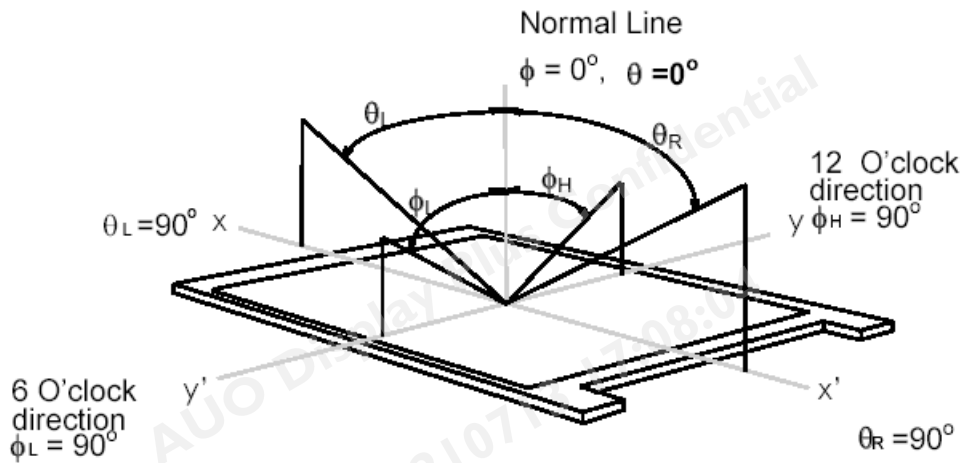

3. Functional Block Diagram

The following diagram shows the functional block of the 8 inches wide Color TFT/LCD 40 Pin four channel Module

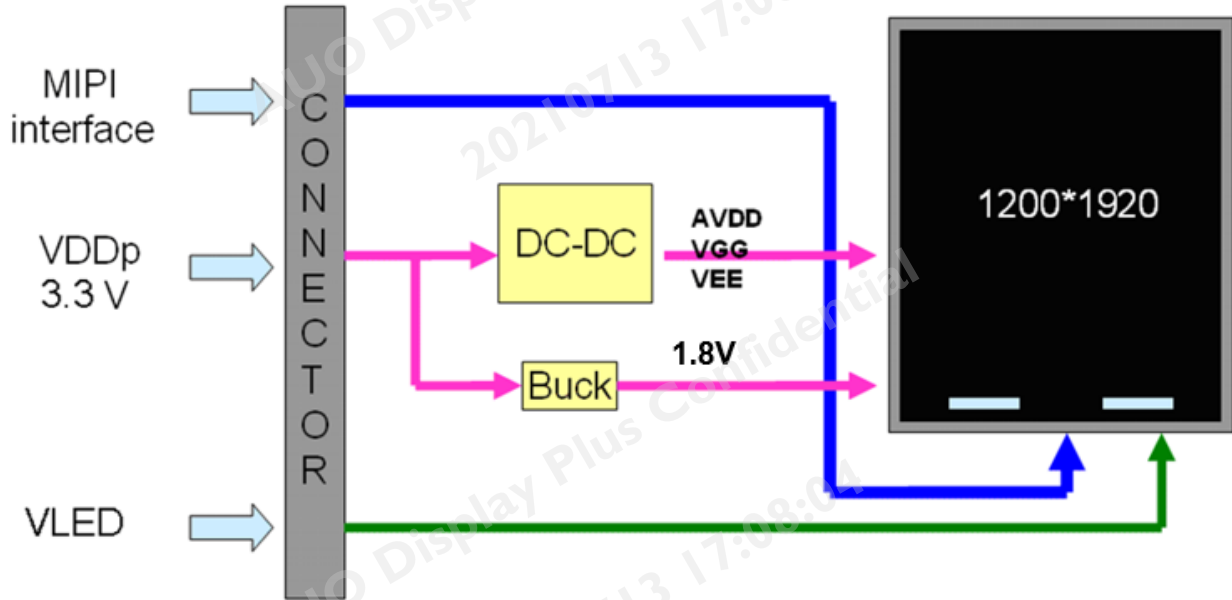



Product Specification

AU OPTRONICS CORPORATION

4. Absolute Maximum Ratings

An absolute maximum rating of the module is as following:

4.1 Absolute Ratings of TFT LCD Module

Item	Symbol	Min	Max	Unit	Conditions
Logic/LCD Drive Voltage	VDD	-0.3	+4	[Volt]	Note 1,2

4.2 Absolute Ratings of Environment

Item	Symbol	Min	Max	Unit	Conditions
Operating Temperature	TOP	-10	+60	[°C]	Note 4
Operation Humidity	HOP	5	95	[%RH]	Note 4
Storage Temperature	TST	-20	+70	[°C]	Note 4
Storage Humidity	HST	5	95	[%RH]	Note 4

Note 1: At Ta (25°C)

Note 2: Permanent damage to the device may occur if exceed maximum values

Note 3: LED specification refer to section 5.2

Note 4: For quality performance, please refer to AUO IIS (Incoming Inspection Standard).

5. Electrical Characteristics

5.1 TFT LCD Module

5.1.1 Power Specification

Input power specifications are as follows;

The power specification are measured under 25°C and frame frequency under 60Hz

Symble	Parameter	Min	Typ	Max	Units	Note
VDD	Logic/LCD Drive Voltage	3.0	3.3	3.6	[Volt]	
PDD	VDD Power	-	-	0.495	[Watt]	Note 1
IDD	IDD Current	-	-	150	[mA]	Note 1
IRush	Inrush Current	-	-	1500	[mA]	Note 2
VDDrp	Allowable Logic/LCD Drive Ripple Voltage	-	-	100	[mV] p-p	

Note 1: Maximum Measurement Condition : White Pattern at 3.3V driving voltage. ($P_{max}=V_{3.3} \times I_{black}$)

Note 2: Measure Condition

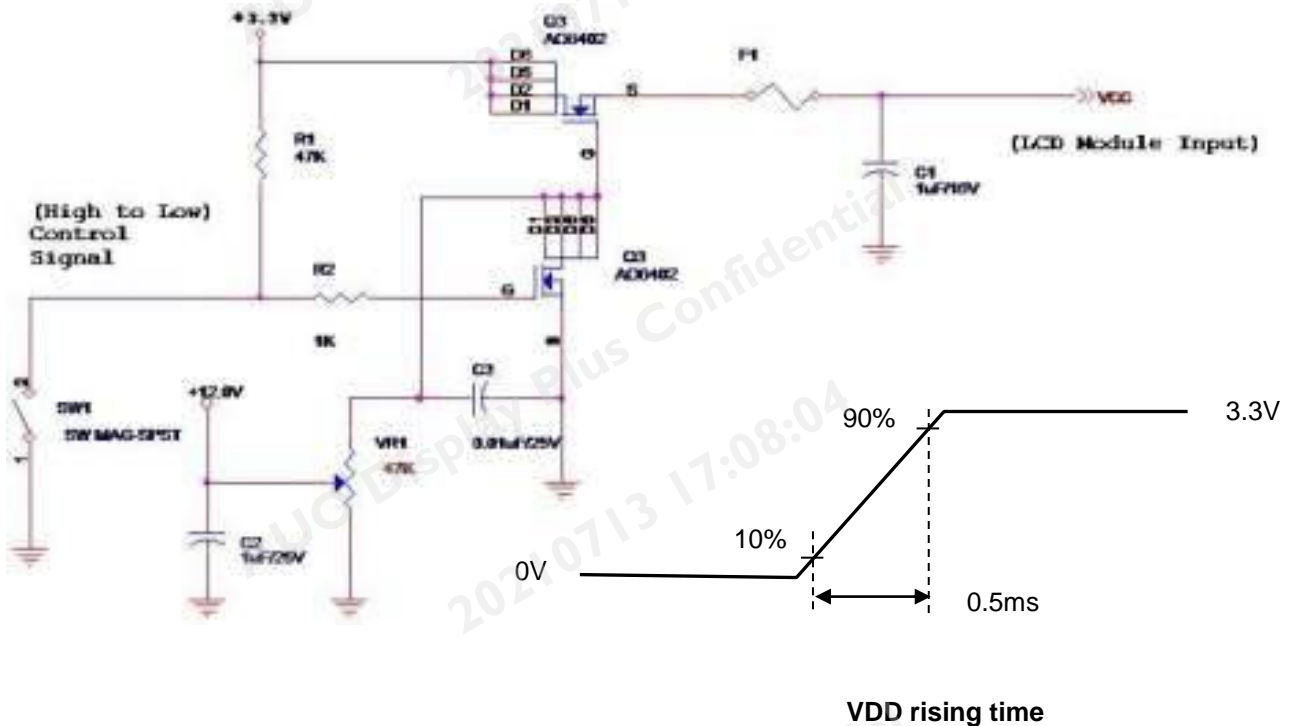

5.1.2 Signal Electrical Characteristics

Input signals shall be low or High-impedance state when VDD is off.

MIPI DC characteristics are as follows:

MIPI Receiver Differential Input (DC Characteristics)					
Symbol	Parameter	Min	Typ	Max	Unit
BR _{MIPI}	Input data bit rate	200	-	1000	Mbps
V _{CMRX}	Common-mode voltage(HS Rx mode)	155	-	330	mV
V _{IDTH}	Differential input high threshold (HS Rx mode)	-	-	70	mV
V _{IDTL}	Differential input low threshold (HS Rx mode)	-70	-	-	mV
V _{IDM}	Differential input voltage range (HS Rx mode)	70	-	500	mV
V _{IHHS}	Single-end input high voltage (HS Rx mode)	-	-	460	mV
V _{ILHS}	Single-end input low voltage (HS Rx mode)	-40	-	-	mV
Z _{ID}	Differential input impedance	80	100	125	Ω
V _{IHLP}	Logic 1 input voltage (LP Rx mode)	880			mV
V _{ILLP}	Logic 0 input voltage (LP Rx mode)			550	mV

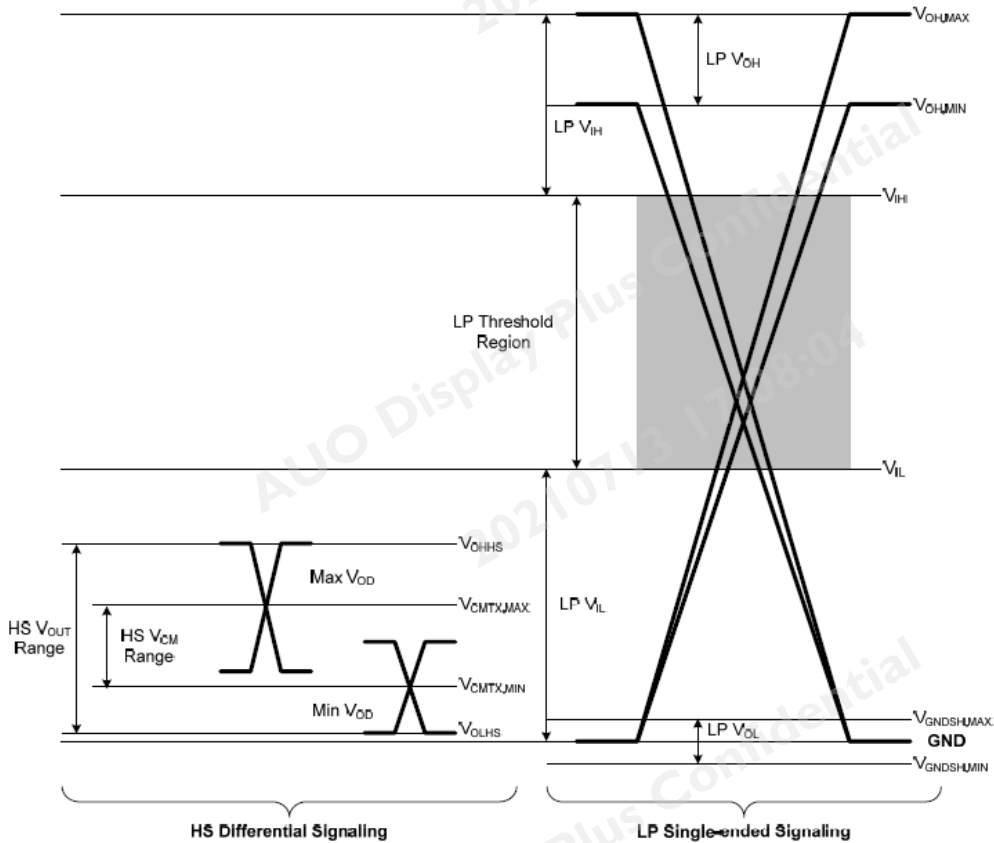

Product Specification

AU OPTRONICS CORPORATION

MIPI Receiver Differential Input (AC Characteristics)

Symbol	Parameter	Conditions	Min	Typ	Max	Unit
$\Delta V_{CMRX(HF)}$	Common-mode interference beyond 450MHz		-	-	100	mV
$\Delta V_{CMRX(LF)}$	Common-mode interference 50MHz ~ 450MHz		-50	-	50	mV
C_{CM}	Common-mode termination		-	-	60	pF
U_{INST}	UI instantaneous		1		12.5	ns

HS RX Scheme

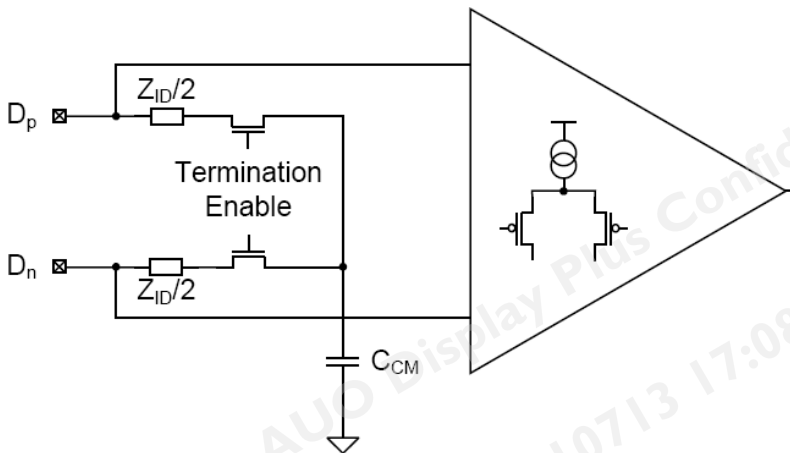

Symbol	Parameter	Min	Typ	Max	Unit	Notes
$T_{SKEW(TX)}$	Data to Clock Skew (measured at transmitter)	-0.15		0.15	U_{INST}	1
$T_{SETUP(RX)}$	Data to Clock Setup Time (receiver)	0.25			U_{INST}	2
$T_{HOLD(RX)}$	Data to Clock Hold Time (receiver)	0.25			U_{INST}	2

Note:

1. Total silicon and package delay budget of $0.25 * U_{INST}$
2. Total setup and hold window for receiver of $0.5 * U_{INST}$

MIPI High-Speed Data-clock Timing

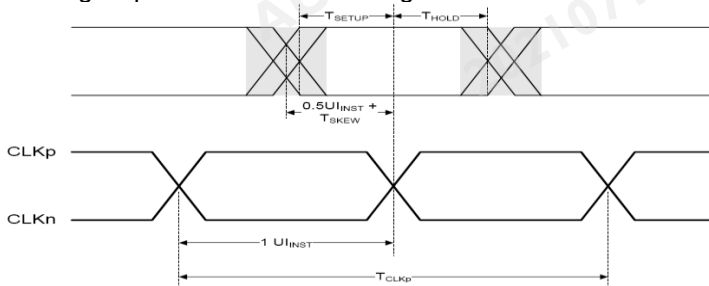

LP Receiver AC Specifications						
Symbol	Parameter	Conditions	Min	Typ	Max	Unit
e_{SPIKE}	Input pulse rejection		-	-	300	V · ps
$T_{\text{MIN-RX}}$	Minimum pulse width response		50	-	-	ns
V_{INT}	Peak interference amplitude		-	-	200	mV
f_{INT}	Interference frequency		450	-	-	MHz

Input Glitch Rejection of Low-Power Receivers

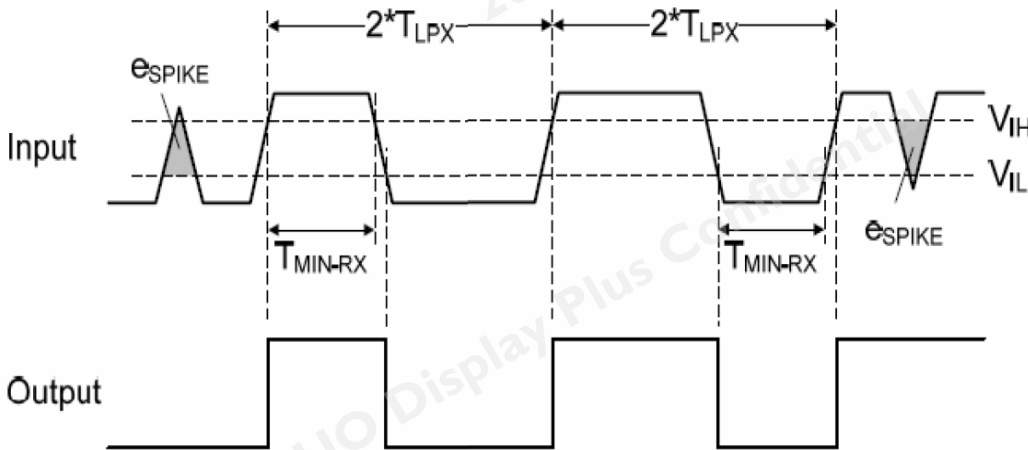

For MIPI data transmission from TX to TCON works properly in video mode, it is suggested that all of MIPI lanes status follow the scheme showed in below. When power is turned on, all lanes (include clock lane) are into LP-11 status first. When TX wants to start transmitting data to TCON, the clock lane is into HS and start toggling. Then data lanes are into HS and data are transmitted. After data transmissions are finished (ex. H-blanking, V-blanking), the data lanes are returned to LP-11, then clock lane, too. The transmission start from LP-11 and stop in LP-11 on all lanes (include clock lane) are the recommended proper operation sequence for MIPI video mode.

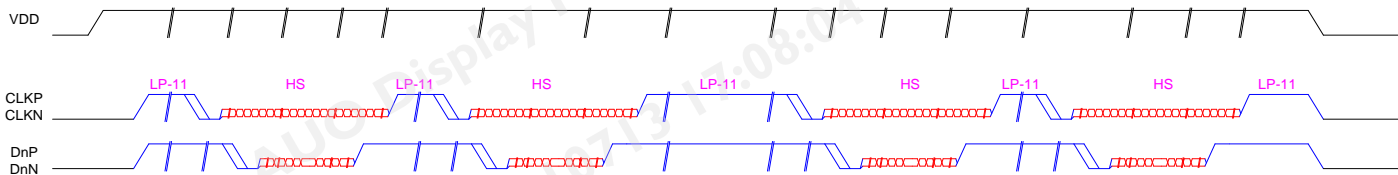

The timing definitions are listed in below,

Parameter	Description	Min	Typ	Max	Unit
TCLK-MISS	Timeout for receiver to detect absence of Clock transitions and disable the Clock Lane HS-RX.			60	ns
TCLK-POST	Time that the transmitter continues to send HS clock after the last associated Data Lane has transitioned to LP Mode. Interval is defined as the period from the end of THS-TRAIL to the beginning	60 ns + 52*UI			ns



Product Specification

AU OPTRONICS CORPORATION

	of TCLK-TRAIL.				
TCLK-PRE	Time that the HS clock shall be driven by the transmitter prior to any associated Data Lane beginning the transition from LP to HS mode.	8			UI
TCLK-PREPARE	Time that the transmitter drives the Clock Lane LP-00 Line state immediately before the HS-0 Line state starting the HS transmission.	38		95	ns
TCLK-SETTLE	Time interval during which the HS receiver shall ignore any Clock Lane HS transitions, starting from the beginning of TCLK-PREPARE.	95		300	ns
TCLK-TERM-EN	Time for the Clock Lane receiver to enable the HS line termination, starting from the time point when Dn crosses VIL,MAX.			38	ns
TCLK-TRAIL	Time that the transmitter drives the HS-0 state after the last payload clock bit of a HS transmission burst.	60			ns
TCLK-PREPARE + TCLK-ZERO	TCLK-PREPARE + time that the transmitter drives the HS-0 state prior to starting the Clock.	300			ns
TD-TERM-EN	Time for the Data Lane receiver to enable the HS line termination, starting from the time point when Dn crosses VIL,MAX.			35 ns + 4*UI	ns
TEOT	Transmitted time interval from the start of THS-TRAIL or TCLK-TRAIL, to the start of the LP-11 state following a HS burst.			105 ns + 12*UI	ns
THS-EXIT	Time that the transmitter drives LP-11 following a HS burst.	100			ns
THS-SYNC	HS Sync-Sequence '00011101' period		8		UI
THS-PREPARE	Time that the transmitter drives the Data Lane LP-00 Line state immediately before the HS-0 Line state starting the HS transmission	40 ns + 4*UI		85 ns + 6*UI	ns
THS-PREPARE + THS-ZERO	THS-PREPARE + time that the transmitter drives the HS-0 state prior to transmitting the Sync sequence.	145 ns + 10*UI			ns



Product Specification

AU OPTRONICS CORPORATION

THS-SETTLE	Time interval during which the HS receiver shall ignore any Data Lane HS transitions, starting from the beginning of THS-PREPARE.	85 ns + 6*UI		145 ns + 10*UI	ns
THS-SKIP	Time interval during which the HS-RX should ignore any transitions on the Data Lane, following a HS burst. The end point of the interval is defined as the beginning of the LP-11 state following the HS burst.	40		55 ns + 4*UI	ns
THS-TRAIL	Time that the transmitter drives the flipped differential state after last payload data bit of a HS transmission burst	60 ns + 4*UI			ns
TLPX	Transmitted length of any Low-Power state period	50			ns
Ratio TLPX	Ratio of TLPX(MASTER)/TLPX(SLAVE) between Master and Slave side	2/3		3/2	
TTA-GET	Time that the new transmitter drives the Bridge state (LP-00) after accepting control during a Link Turnaround.		5*TLPX		ns
TTA-GO	Time that the transmitter drives the Bridge state (LP-00) before releasing control during a Link Turnaround.		4*TLPX		ns
TTA-SURE	Time that the new transmitter waits after the LP-10 state before transmitting the Bridge state (LP-00) during a Link Turnaround.	TLPX		2*TLPX	ns

Note:

1. The minimum value depends on the bit rate. Implementations should ensure proper operation for all the supported bit rates.
2. TLPX is an internal state machine timing reference. Externally measured values may differ slightly from the specified values due to asymmetrical rise and fall times.
3. The I-chip of AUO use is not support BTA (BTA define ignore).

High-Speed Data Transmission in Bursts

Product Specification

AU OPTRONICS CORPORATION

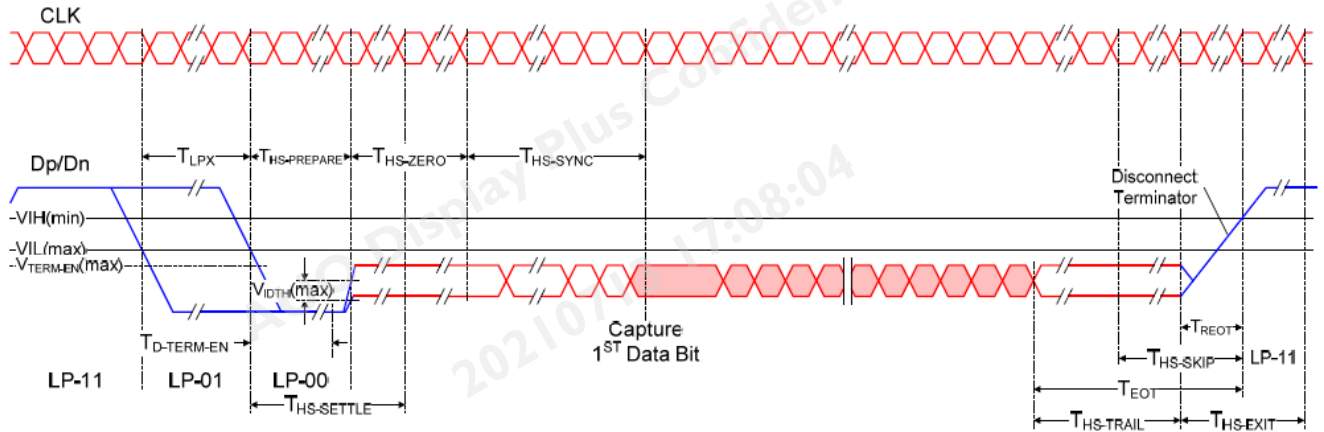

Switching the Clock Lane between Clock Transmission and Low-Power Mode

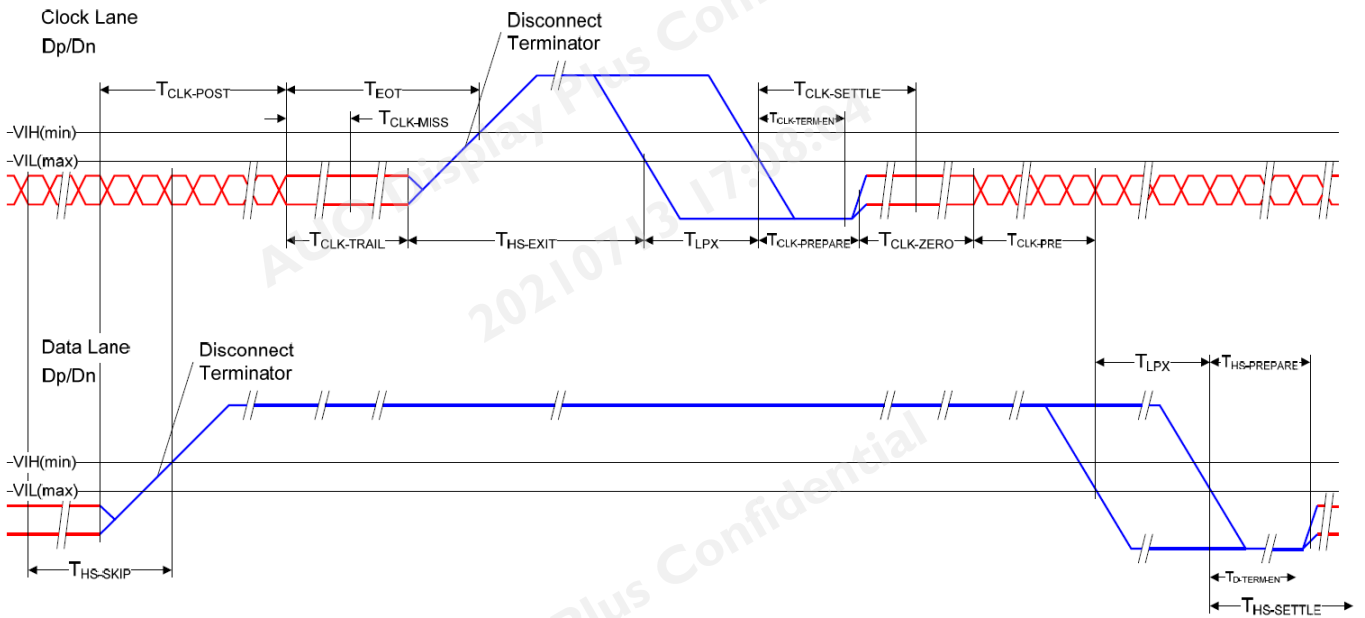

Turnaround Procedure

5.2 Backlight Unit

5.2.1 LED characteristics

Parameter	Symbol	Min	Typ	Max	Units	Condition
Backlight Power Consumption	PLED	-	1.39	1.40	[Watt]	(Ta=25°C) Note1.
LED Life-Time	N/A	15k	-	-	Hour	(Ta=25°C) Note2.
LED Forward Voltage	VF	2.73	2.88	2.90	[Volt]	(Ta=25°C)
LED Forward Voltage of every LED string	VF-string	-	20.16	20.30	[Volt]	(Ta=25°C) Note3.
LED Forward Current	IF	-	23	-	[mA]	(Ta=25°C)

Note 1: Calculator value for reference $P_{LED} = V_F$ (Normal Distribution) * I_F (Normal Distribution) / Efficiency

Note 2: The LED life-time define as the estimated time to 50% degradation of initial luminous.

The LEDs arrangement of Light bar:

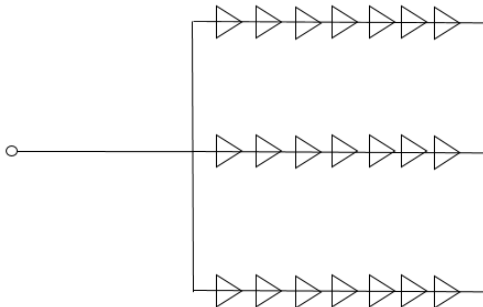

6. Signal Interface Characteristic

6.1 Pixel Format Image

Following figure shows the relationship of the input signals and LCD pixel format.

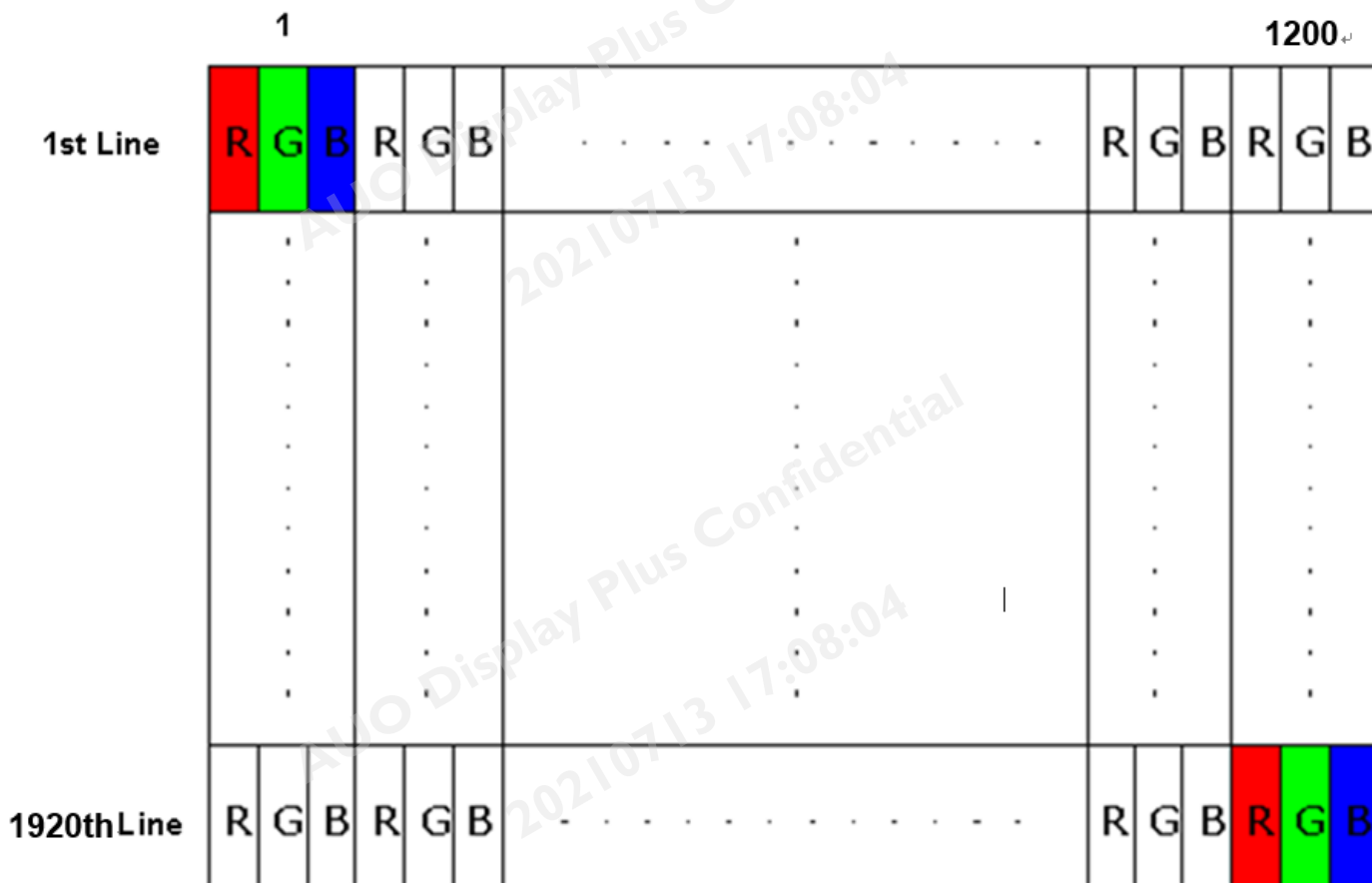

6.2 Integration Interface Requirement

6.2.1 Connector Description

Physical interface is described as for the connector on module.

These connectors are capable of accommodating the following signals and will be following components.

MIPI connector:

Connector Name / Designation	For Signal Connector
Manufacturer	HRS
Type / Part Number	FH34SRJ-40S-0.5SH or compatible
Mating Housing/Part Number	FPC

6.2.2 Pin Assignment

MIPI lane is a differential signal technology for LCD interface and high speed data transfer device.

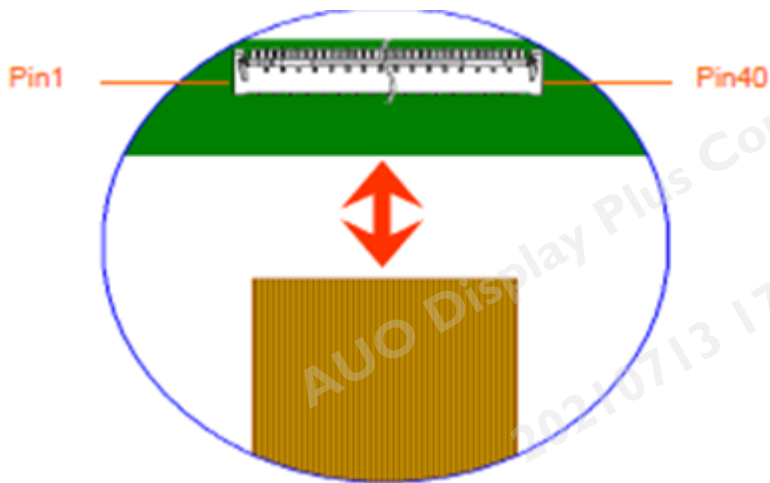

Pin	Symbol	Description
1	LED+	Anode for light bar
2	LED+	Anode for light bar
3	NC	No connection
4	LED1-	Cathode for light bar
5	LED2-	Cathode for light bar
6	LED3-	Cathode for light bar
7	NC	No connection
8	NC	No connection
9	NC	No connection
10	NC	No connection
11	NC	No connection
12	NC	No connection
13	ID	High
14	VDD	3.3V input power
15	VDD	3.3V input power
16	VDD	3.3V input power
17	NC	No connection
18	REZX	Device reset signal
19	LEDPWM_OUT	PWM control signal for LED driver(CABA)
20	GND	Ground
21	GND	Ground
22	NC	No connection
23	NC	No connection
24	NC	No connection
25	GND	Ground
26	D0+	MIPI differential data 0 input(Positive)

27	D0-	MIPI differential data 0 input(Negative)
28	GND	Ground
29	D1+	MIPI differential data 1 input(Positive)
30	D1-	MIPI differential data 1 input(Negative)
31	GND	Ground
32	CLK+	MIPI differential data CLK input(Positive)
33	CLK-	MIPI differential data CLK input(Negative)
34	GND	Ground
35	D2+	MIPI differential data 2 input(Positive)
36	D2-	MIPI differential data 2 input(Negative)
37	GND	Ground
38	D3+	MIPI differential data 3 input(Positive)
39	D3-	MIPI differential data 3 input(Negative)
40	GND	GND

6.3 Interface Timing

6.3.1 Timing Characteristics

Basically, interface timings should match the 1200 x 1920 /60 Hz manufacturing guide line timing.

Parameter		Symbol	Min.	Typ.	Max.	Unit
Frame Rate		---	---	60	---	Hz
Clock frequency		$1/T_{\text{Clock}}$	477	499	500	MHz
Vertical Section	Period	T_v	1981	1981	1982	T_{Line}
	Active	T_{vd}	1920			
	Blanking	T_{vb}	61	61	62	
Horizontal Section	Period	T_h	1275	1341	1342	T_{Clock}
	Active	T_{hd}	1200			
	Blanking	T_{hb}	75	141	142	

6.3.2 Timing diagram

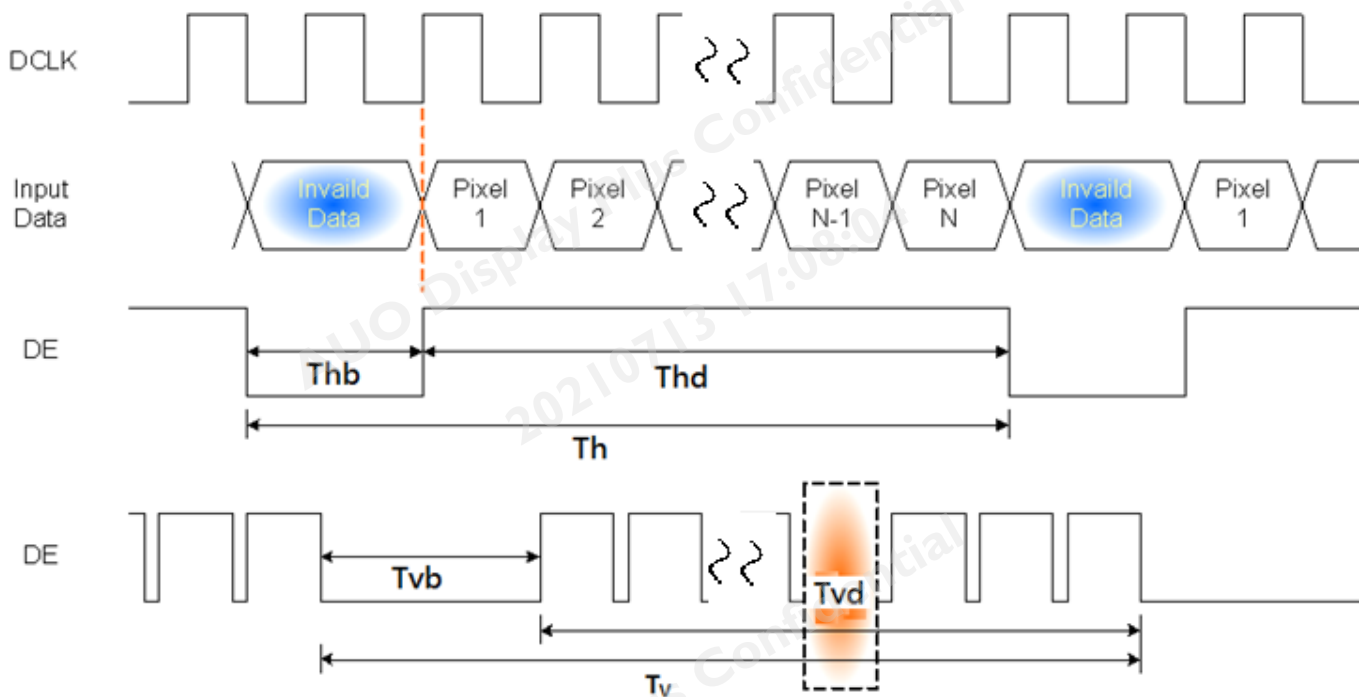

6.4 Power On/Off Sequence

6.4.1 Power On/Off Sequence

Power on/off sequence is as follows. Interface signals and LED on/off sequence are also shown in the chart.

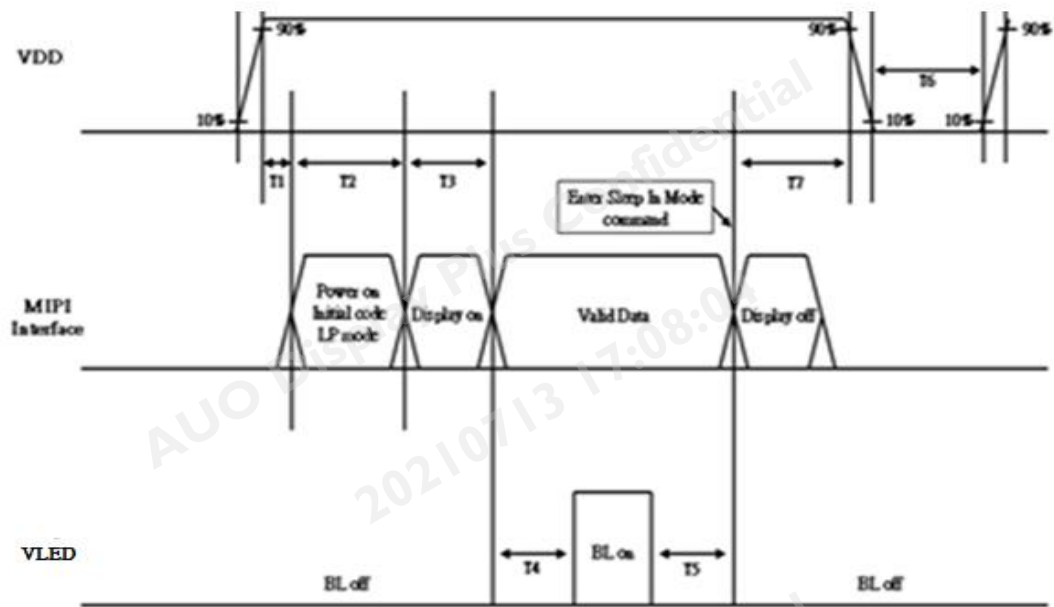

Parameter	Value			Unit	Remark
	Min.	Typ.	Max.		

T1	5			ms	
T2		0		ms	
T3		0		ms	
T4	200			ms	
T5	200			ms	
T6	200			ms	
T7	120			ms	

6.4.2 MIPI Command

NO	Type	Remark
1	Sleep in/ out	Sleep in:0x10, sleep out:0x11,
2	Display on/off	Display on:0x29 Display off:0x28

7. Panel Reliability Test

7.1 Vibration Test

Test Spec:

- Test method: Non-Operation
- Acceleration: 1.5 G
- Frequency: 10 - 500Hz Random
- Sweep: 30 Minutes each Axis (X, Y, Z)

7.2 Shock Test

Test Spec:

- Test method: Non-Operation
- Acceleration: 220 G , Half sine wave
- Active time: 2 ms
- Pulse: X,Y,Z .one time for each side

7.3 Reliability Test

Items	Required Condition	Note
Temperature	Ta= 40°C 90%RH, 240h	

Humidity Bias		
High Temperature Operation	Ta= 60°C Dry, 240h	
Low Temperature Operation	Ta= -10°C, 240h	
High Temperature Storage	Ta= 70°C, 240h	
Low Temperature Storage	Ta= -20°C, 240h	
Thermal Shock Test	Ta=-10°Cto 60°C, Duration at 30 min, 100 cycles	
ESD	Contact : ±4 KV Air : ±8 KV	Note 1

Note1: According to EN 61000-4-2 , ESD class B: Some performance degradation allowed. Self-recoverable.

No data lost, No hardware failures.

Remark: MTBF (Excluding the LED): 30,000 hours with a confidence level 90%

8. Mechanical Characteristics

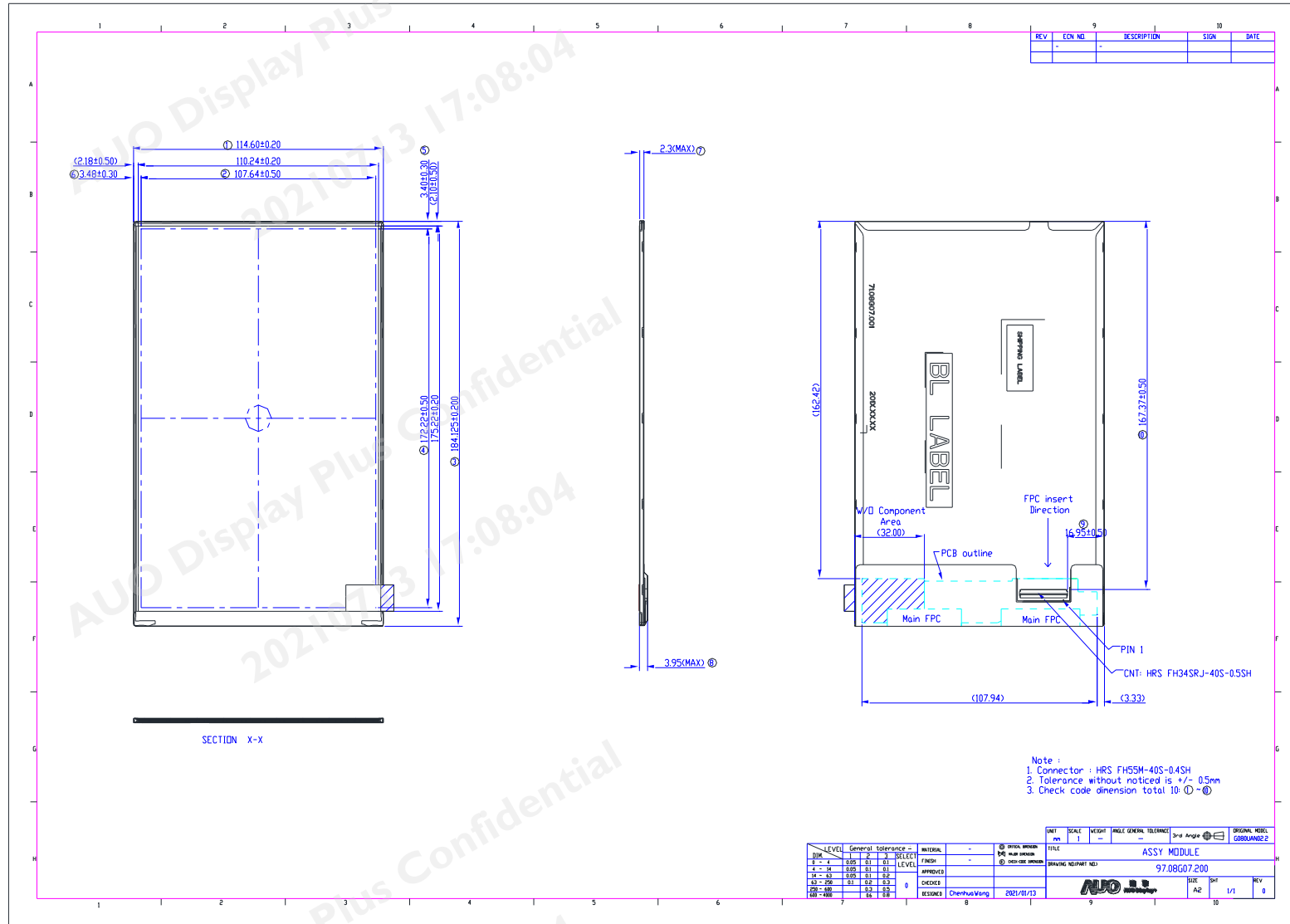

9. Shipping and Package

9.1 Shipping Label Format

Shipping label:



9.2 Carton Label

(a) AUO Standard Label

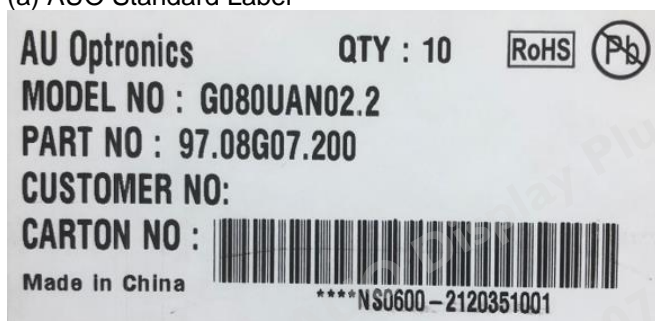

(b) Carton ROHS Label

产品中有毒有害物质或元素的名称及含量						
部件名称	有毒有害物质或元素					
	铅 (Pb)	汞 (Hg)	镉 (Cd)	六价铬 (Cr(VI))	多溴联苯 (PBB)	多溴二苯醚 (PBDE)
LCD PANEL	X	0	0	0	0	0

0: 表示有害有毒物质在该部件所有均质材料中的含量在 GB/T 26572-2011 标准规定的限量要求以下
X: 表示有害有毒物质至少在该部件的某一均质材料中的含量超出 GB/T 26572-2011 标准规定的限量要求。
X: 符合国推污染控制认证限用物质应用例外要求

9.3 Shipping Package of Palletizing Sequence

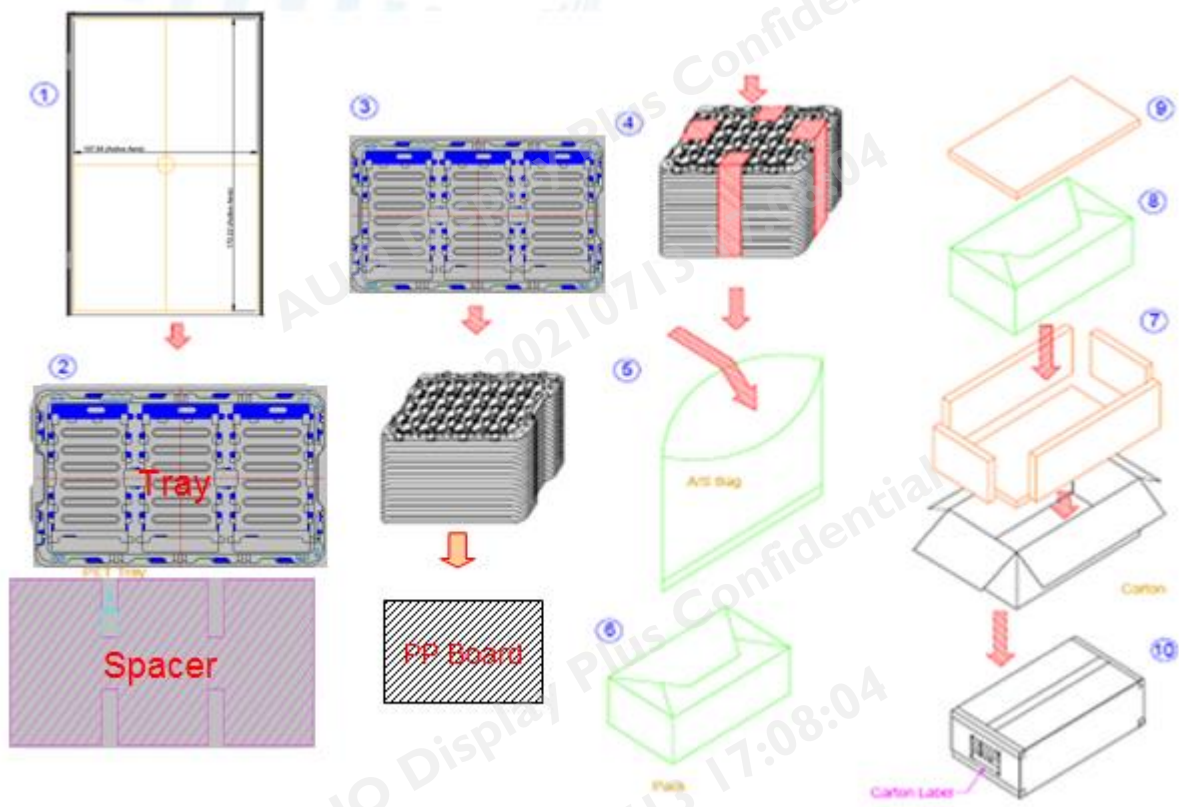

- 6 pcs/tray
- (11+1)trays/carton
- Total 66 pcs panel/carton
- Total carton weight : 10.2 Kg
- Carton type: 520*340*250mm
- PP Board : Put it on the bottom of the Tray