

# GNSS RTK Module

## TAU1308

Datasheet V1.4

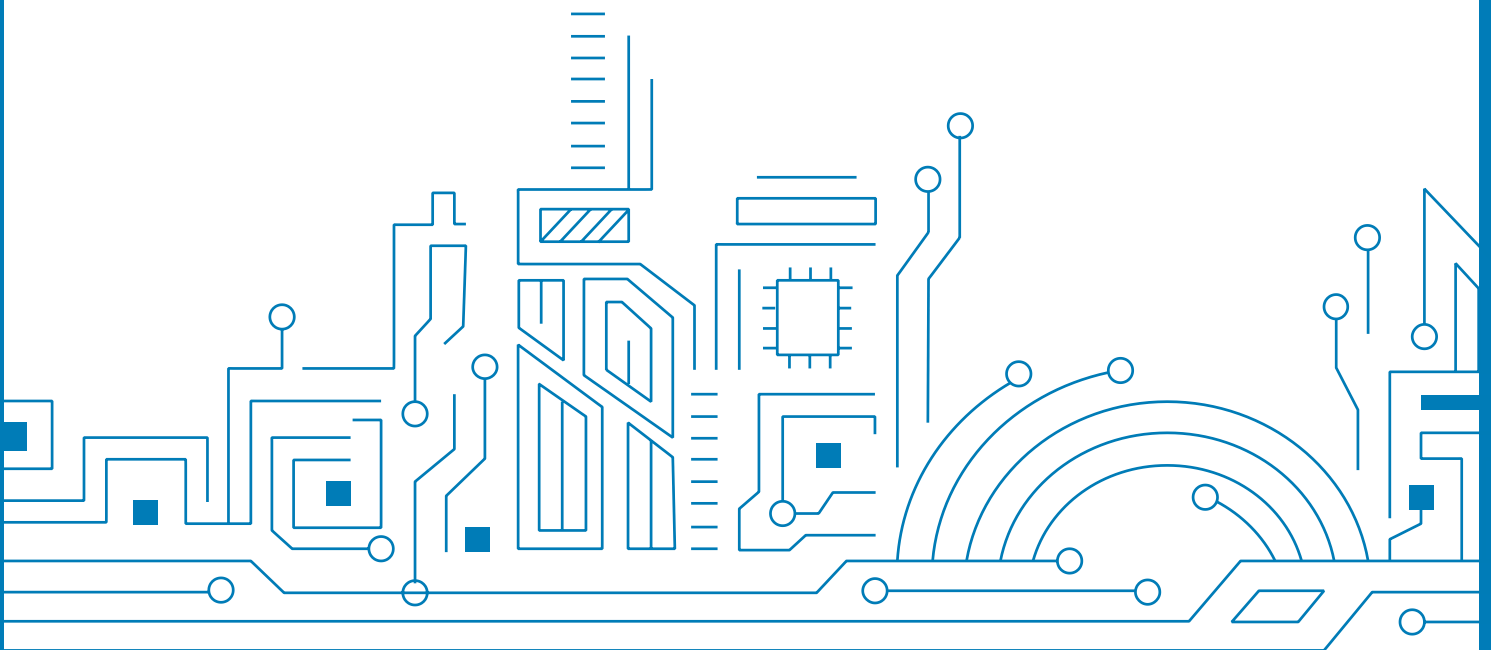

## Notice, Statement and Copyright

ALLYSTAR Technology offers this document as a service to its customers, to support application and engineering efforts that use the products designed by ALLYSTAR Technology. Products and specifications discussed herein are for reference purposes only. Performance characteristics listed in this document do not constitute a warranty or guarantee of product performance.

ALLYSTAR Technology assumes no liability or responsibility for any claims or damages arising out of the use of this document, or from the use of integrated circuits based on this document, including, but not limited to claims or damages based on infringement of patents, copyrights or other intellectual property rights.

This document contains proprietary technical information which is the property of ALLYSTAR Technology, copying of this document and giving it to others and using or communication of the contents thereof, are forbidden without express authority. Offenders are liable to the payment of damages. ALLYSTAR Technology reserves the right to make changes in its products, specifications and other information at any time without notice.

For more recent documents, please visit [www.allystar.com](http://www.allystar.com).

Copyright © Allystar Technology (Shenzhen) Co., Ltd. 2021. All rights reserved.

## About the Document

### ■ Basic info

<b>Document applies to</b>	TAU1308
<b>Document type</b>	Datasheet
<b>Revision and date</b>	V1.4/2021-07
<b>Product status</b>	Mass production

### ■ Product status description

<b>In development</b>	Objective specification. Revision may be released in later status.
<b>Engineering sample</b>	Product specifications tested on early. Revision may be released in later status.
<b>Preliminary</b>	Product specifications come from small production. Revision may be released in later status.
<b>Mass production</b>	Final product specification to mass market.

## TABLE OF CONTENT

<b>1</b>	<b>SYSTEM OVERVIEW .....</b>	<b>6</b>
1.1	Overview .....	6
1.2	Features .....	6
1.3	Module photo .....	6
1.4	Block diagram .....	7
1.5	Specifications .....	8
<b>2</b>	<b>PIN DESCRIPTION .....</b>	<b>9</b>
2.1	Pin assignment .....	9
2.2	Detailed pin descriptions .....	9
<b>3</b>	<b>ELECTRICAL CHARACTERISTICS .....</b>	<b>11</b>
3.1	Absolute maximum rating .....	11
3.2	IO Characteristics .....	11
3.2.1	PRRSTX and PRTRG .....	11
3.2.2	USB I/O .....	11
3.2.3	Others .....	12
3.3	DC characteristics .....	12
3.3.1	Operating Conditions .....	12
3.3.2	Power Consumption .....	12
<b>4</b>	<b>HARDWARE DESCRIPTION .....</b>	<b>13</b>
4.1	Connecting power .....	13
4.2	Power on/off Sequence .....	13
4.2.1	Initial system power on .....	13
4.2.2	Main power supply off/on in application .....	14
4.3	Antenna design .....	14
4.4	Reset and mode control .....	15
4.5	Serial interfaces .....	15
4.5.1	Default message .....	15
4.5.2	USB .....	16
4.5.3	SPI .....	16
4.5.4	I2C .....	16
<b>5</b>	<b>MECHANICAL SPECIFICATION .....</b>	<b>17</b>
<b>6</b>	<b>REFERENCE DESIGN .....</b>	<b>18</b>
6.1	Minimal Design .....	18
6.2	PCB Footprint Reference .....	18
6.3	Layout Notes .....	19
<b>7</b>	<b>PRODUCT PACKAGING AND HANDLING .....</b>	<b>20</b>
7.1	Packaging .....	20
7.1.1	Packaging Notes .....	20
7.1.2	Tape and Reel .....	20
7.1.3	Shipment Packaging .....	21
7.2	Storage .....	22
7.3	ESD Handling .....	22
7.3.1	ESD Handling Precautions .....	22
7.3.2	ESD protection measures .....	22
7.3.3	Moisture sensitivity level .....	22
<b>8</b>	<b>LABELING AND ORDERING INFORMATION .....</b>	<b>23</b>

8.1	Labeling .....	23
8.2	Ordering info .....	23
<b>9</b>	<b>RELATED DOCUMENTS .....</b>	<b>24</b>
<b>10</b>	<b>REVISION HISTORY .....</b>	<b>24</b>

### List of tables

Table 1	TAU1308 .....	6
Table 2	Specifications .....	8
Table 3	Detailed pin descriptions .....	9
Table 4	Absolute rating .....	11
Table 5	PRRSTX and PRTRG .....	11
Table 6	USB signal .....	11
Table 7	Others .....	12
Table 8	DC characteristics .....	12
Table 9	Power consumption .....	12
Table 10	ANT_BIAS current range and antenna status .....	14
Table 11	Default message .....	15
Table 12	Dimensions .....	17
Table 13	Packing hierarchy .....	20
Table 14	Labeling content .....	23
Table 15	Ordering codes .....	23

### List of figures

Figure 1	TAU1308 module photo .....	6
Figure 2	Block diagram .....	7
Figure 3	Pin assignment (top view) .....	9
Figure 4	Initial system power on sequence .....	13
Figure 5	Main power on sequence .....	14
Figure 6	Dimensions .....	17
Figure 7	Minimal application diagram .....	18
Figure 8	PCB Footprint Reference .....	18
Figure 9	Tape dimensions .....	20
Figure 10	Reel dimensions .....	21
Figure 11	Packaging .....	21

# 1 SYSTEM OVERVIEW

## 1.1 Overview

TAU1308 is developed on the base of HD9301 GNSS chip. It is a positioning system that combines GPS, BeiDou, GLONASS, Galileo, and QZSS to provide a high precision positioning and navigation solution. With built-in single-band RTK engine, TAU1308 can achieve centimeter-level position accuracy, which makes it suitable for the industrial and consumer fields.

## 1.2 Features

- Supports GPS, BDS, GLONASS, Galileo, and QZSS
- Centimeter-level GNSS positioning
- Integrated Real Time Kinematics (RTK)
- Active antenna short circuit protection
- Configurable peripheral IO pins
- Low power consumption
- Single supply with wide voltage range

**Table 1 TAU1308**

Product	GNSS						Features						Interfaces			Accuracy		Grade					
	Band (S/D/T)	GPS	BDS	GLONASS	Galileo	NavIC	Built-in LNA	Programmable (flash)	Data logging	D-GNSS	Oscillator	Raw Data	RTK	UART	I2C	USB	SPI	Meter	Sub-meter	Centimeter	Standard	Professional	Automotive
TAU1308-1216A00	S	●	●	●	●			●	●	●	T	●	●	○	○	○			●		●		

T= TCXO

○=Supported upon request with special FW

## 1.3 Module photo



**Figure 1 TAU1308 module photo**

## 1.4 Block diagram

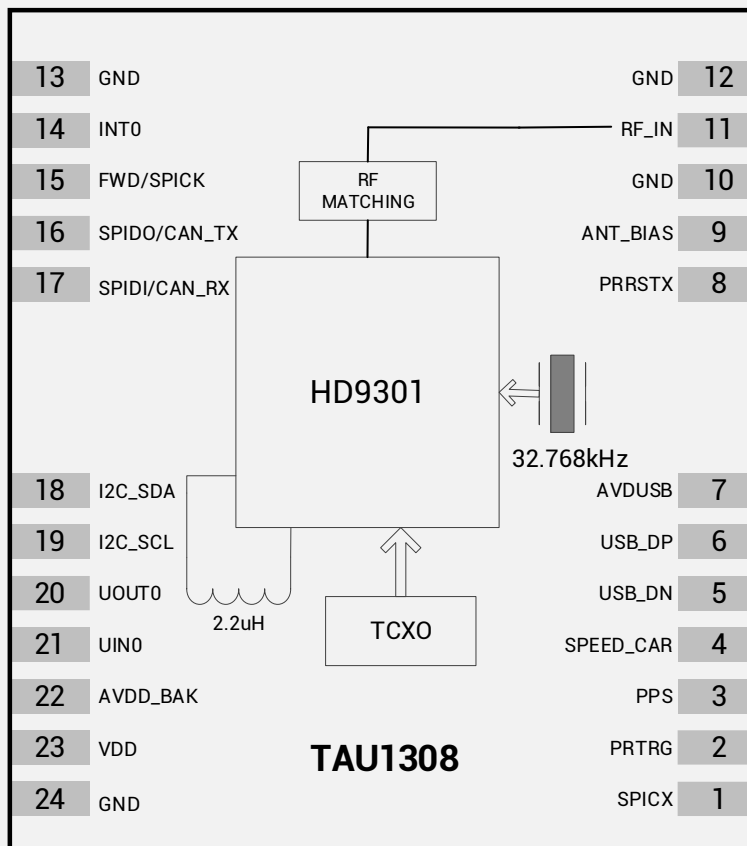

Figure 2 Block diagram

## 1.5 Specifications

**Table 2 Specifications**

Parameter	Specification	
GNSS tracking channels	40	
GNSS reception	GPS/QZSS: L1C/A BDS: B1I GLONASS: L1OF Galileo: E1	
Update rate	Maximum 10Hz	
Position accuracy <sup>[1]</sup>	GNSS	2.5 m CEP
	RTK	2.5 cm+1 ppm (V) 1.0 cm+1 ppm (H)
	D-GNSS	<1m CEP
Velocity & Time accuracy	GNSS	0.1 m/s CEP
	D-GNSS	0.05 m/s CEP
	1PPS	20 ns
Time to First Fix(TTFF)	Hot start	1 sec
	Cold start	28 secs
Convergence time	RTK	< 60 secs
Sensitivity	Cold start	-147 dBm
	Hot start	-153 dBm
	Reacquisition	-156 dBm
	Tracking & navigation	-160 dBm
Operating condition	Main voltage	2.0-3.6 V
	Digital I/O voltage	1.8-3.6 V
	Backup voltage	1.8-3.6 V
Power consumption	Operating(GNSS, L1)	32 mA @ 3.3 V
	Standby	13 uA
Interfaces	UART	1
	USB <sup>[2]</sup>	1
	SPI (master/slave) <sup>[2]</sup>	1
	I <sup>2</sup> C <sup>[2]</sup>	1
Protocol	RTCM 3.0/3.2/2.3/2.4x <sup>[3]</sup> NMEA 0183 Protocol Ver. /4.00/4.10 Cynosure GNSS Receiver Protocol	
Operating limit	Velocity	515 m/s
	Altitude	18,000 m
Operating temperature	-40°C ~ +85°C	
Storage temperature	-40°C ~ +85°C	
Dimensions	12.2mm x 16.0mm x 2.4mm	
Certification	RoHS, REACH, FCC, CE	

\* [1] Open sky, single band, demonstrated with a good external LNA

\* [2] Supported upon request with special FW

\* [3] RCTM 2.3/2.4 are supported upon request with special firmware.



## 2 PIN DESCRIPTION

### 2.1 Pin assignment

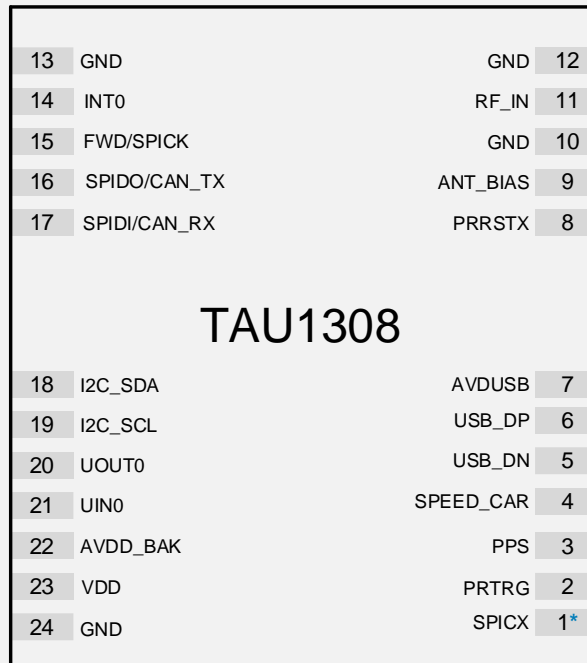

\* Pin 1 aligns to the circular hole on module cover.

**Figure 3 Pin assignment (top view)**

### 2.2 Detailed pin descriptions

**Table 3 Detailed pin descriptions**

Function	Symbol	No.	I/O	Description
Power	VDD	23	Power	Main power supply voltage.
	GND	10,12,13,24	VSS	Ground
	AVDD_BAK	22	Power	Backup power supply voltage input.
	AVDUSB	7	Power	USB power supply voltage.
Antenna	RF_IN	11	I	The connection to the antenna must be routed on the PCB. Use a controlled impedance of 50Ω to connect RF_IN to the antenna or the antenna connector.
	ANT_BIAS	9	O	RF section output voltage. The ANT_BIAS pin can be used to supply power to an external active antenna.
UART	UOUT0	20	O	UART0 serial data output.
	UINO	21	I	UART0 serial data input.
USB <sup>[1]</sup>	USB_DN	5	I/O	USB I/O line. USB bidirectional

	USB_DP	6	I/O	communication pin. Leave it floating if not used.
SPI <sup>[1]</sup>	SPICX	1	0	SPI chip select
	FWD/SPICK	15	0	SPI clock output.
	SPIDO/CAN_TX	16	0	SPI data output. Leave it floating if not used.
	SPIDI/CAN_RX <sup>1</sup>	17	I	SPI data input. Leave it floating if not used.
I2C <sup>[1]</sup>	I2C_SDA	18	I/O	I2C data. Leave it floating if not used.
	I2C_SCL	19	I/O	I2C clock. Leave it floating if not used.
System	PRTRG	2	I	Mode selection, or wake up signal input.
	PRRSTX	8	I	External reset, low active
	PPS	3	0	Configuration Time pulse signal (one pulse per second by default). Leave it floating if not used. Default is GPIO.
	SPEED_CAR <sup>[1]</sup>	4	I	Car speed pulse input. Leave it floating if not used.
	INT0	14	I	External interrupt pin. Leave it floating if not used.

\* [1] Supported upon request with special FW

## 3 ELECTRICAL CHARACTERISTICS

### 3.1 Absolute maximum rating

This product contains devices to protect the inputs from high static voltage damage. However, it is advisable to take appropriate precautions to avoid application of any voltage higher than the specified maximum rated voltages. Stresses above those listed under “Absolute Maximum Ratings” may cause permanent damage to the device.

**Table 4 Absolute rating**

Symbol	Parameter	Min.	Max.	Unit
VDD	Power supply voltage	-0.5	3.6	V
AVDD_BAK	Backup battery voltage	-0.5	3.6	V
AVDUSB	USB supply voltage	-0.5	3.6	V
V <sub>I</sub> max	Input pin voltage	-0.5	3.6	V
T <sub>storage</sub>	Storage temperature range	-40	85	°C
T <sub>solder</sub>	Solder reflow temperature	--	260	°C

### 3.2 IO Characteristics

#### 3.2.1 PRRSTX and PRTRG

**Table 5 PRRSTX and PRTRG**

Symbol	Parameter	Condition	Min.	Typ.	Max.	Unit
I <sub>Iz</sub>	Input leakage current	--	--	--	+/-1	uA
V <sub>IH</sub>	Input high voltage	--	AVDD_BAK*0.7	--	AVDD_BAK	V
V <sub>IL</sub>	Input low voltage	--	0	--	AVDD_BAK*0.3	V
C <sub>i</sub>	Input capacitance	--	--	--	10	pF
R <sub>PU</sub>	Pull-up resistance	--	18	--	84	kΩ

#### 3.2.2 USB I/O

**Table 6 USB signal**

Symbol	Parameter	Condition	Min.	Typ.	Max.	Unit
I <sub>Iz</sub>	Input leakage current	--	--	--	+/-10	uA
V <sub>IH</sub>	Input high voltage	--	AVDUSB*0.9	--	AVDUSB	V
V <sub>IL</sub>	Input low voltage	--	0	--	AVDUSB*0.1	V
V <sub>OH</sub>	Output high voltage	I <sub>OH</sub> =10 mA, AVDUSB =3.3V	2.35	--	--	V
V <sub>OL</sub>	Output low voltage	I <sub>OL</sub> =10 mA, AVDUSB =3.3V	--	--	0.5	V
R <sub>PUIDEL</sub>	Pull-up resistance, idle state	--	0.9	--	1.575	kΩ
R <sub>PUACTIVE</sub>	Pull-up resistance, active state	--	1.425	--	3.09	kΩ

### 3.2.3 Others

**Table 7 Others**

Symbol	Parameter	Condition	Min.	Typ.	Max.	Unit
I <sub>IZ</sub>	Input leakage current	--	--	--	+/-1	uA
V <sub>IH</sub>	Input high voltage	--	VDD*0.7	--	VDD	V
V <sub>IL</sub>	Input low voltage	--	0	--	VDD*0.3	V
V <sub>OH</sub>	Output high voltage	I <sub>OH</sub> =11.9 mA, VDD=3.3V	2.64	--	--	V
V <sub>OL</sub>	Output low voltage	I <sub>OL</sub> =7.9 mA, VDD=3.3V	--	--	0.4	V
C <sub>i</sub>	Input capacitance	--	--	--	11	pF
R <sub>PU</sub>	Pull-up resistance	-	35	--	84	kΩ

## 3.3 DC characteristics

### 3.3.1 Operating Conditions

**Table 8 DC characteristics**

Symbol	Parameter	Min.	Typ.	Max.	Unit
VDD	Power supply voltage	2.0	3.3	3.6	V
AVDD_BAK	Backup supply voltage	1.8	3.3	3.6	V
AVDUSB	USB supply voltage	2.6	3.3	3.6	V
I <sub>ANT_BIAS</sub>	ANT_BIAS output current	-	-	35	mA
V <sub>ANT_BIAS</sub>	ANT_BIAS output voltage	-	VDD-0.2	-	V
ICC <sub>max</sub>	Maximum operating current @ VDD	--	--	200	mA
T <sub>env</sub>	Operating temperature range	-40	--	85	°C

### 3.3.2 Power Consumption

**Table 9 Power consumption**

Symbol	Parameter	Measure Pin	Typ.	Unit
I <sub>CCR1</sub>	Average tracking current (GNSS, L1 only)	VDD <sup>[1]</sup>	32	mA
I <sub>CCDBM</sub>	Standby Mode	AVDD_BAK <sup>[2]</sup>	13	uA

\* [1] Condition: VDD=3.3V@Room Temperature; All Pins Open.

\* [2] Condition: AVDD\_BAK=3.3V@Room Temperature; All Pins Open.

## 4 HARDWARE DESCRIPTION

### 4.1 Connecting power

TAU1308 positioning module has two power supply pins: VDD and AVDD\_BAK. The main power is supplied through the VDD pin, and the backup power is supplied through the AVDD\_BAK pin. In order to ensure the positioning performance, please control the ripple of the module power supply. It is recommended to use the LDO above 200mA.

If the power for VDD pin is off, the real-time clock (RTC) and battery backed RAM (BBR) will be supplied through the AVDD\_BAK pin. Thus, orbit information and time can be maintained and will allow a Hot or Warm start. If no backup battery is connected, the module will perform a cold start at every power-up if no aiding data are sent to the receiver.

**Note:** If no backup supply is available, connect the AVDD\_BAK pin to VDD or leave it floating.

### 4.2 Power on/off Sequence

The module has two independent power domains (backup and main domain). In data backup mode, main power supply can be completely shut down for further power reduction for ultra-low power application.

#### 4.2.1 Initial system power on

When both backup and main supply power on from their off state, external reset (PRRSTX) must be active and hold more than 5ms after both backup supply and main supply reach the minimum operating voltage. Initial system power on sequence is illustrated in Figure 4.

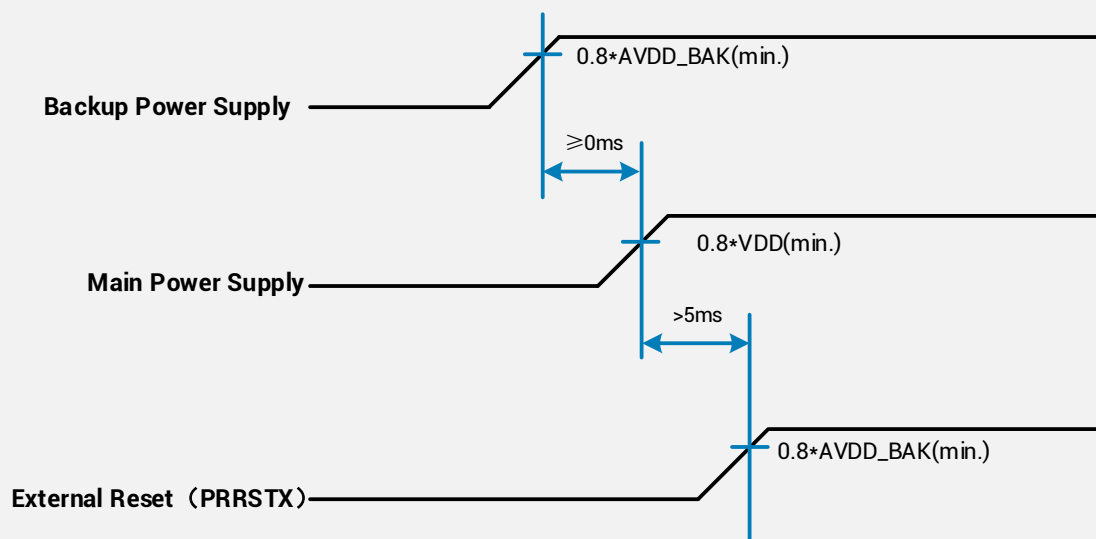

Figure 4 Initial system power on sequence

### 4.2.2 Main power supply off/on in application

If application intends to shut down main power supply (VDD) while keep backup power supply (AVDD\_BAK) alive to save backup data, the following rules should be applied:

External reset (PRRSTX) must be active when main power supply is under power off. In this case, external reset must be hold active more than 5ms after main power supply resumes to minimum operating voltage. Main power on sequence in application is illustrated in Figure 5.

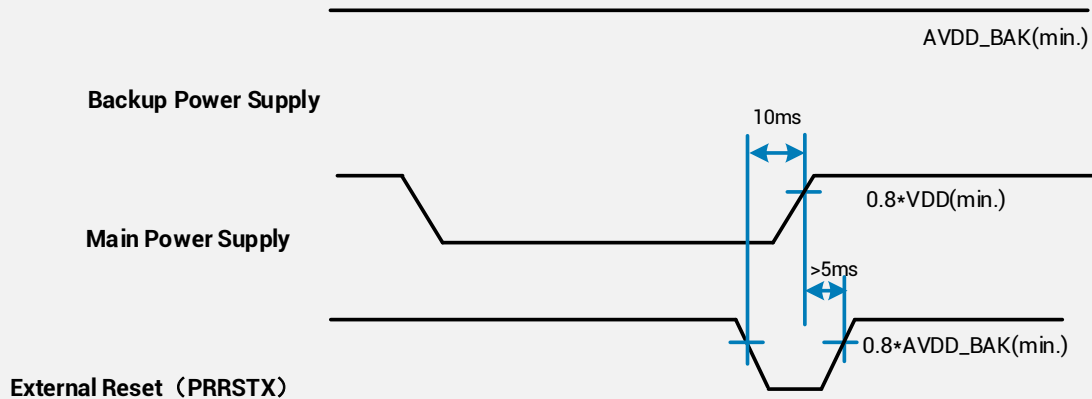

Figure 5 Main power on sequence

## 4.3 Antenna design

It is recommended to use an active antenna with gain less than 50dB and the noise figure less than 1.5dB. The module has built-in short circuit protection and open circuit detection functions, which can detect the status of normal connection, and send out antenna status prompt message in NMEA data.

- **Short circuit protection**
  - » The module includes internal short circuit antenna detection. Once an overcurrent is detected at the ANT\_BIAS port, the module will restrict the current output automatically to protect from damage.
- **Open circuit detection**
  - » The module can detect an open circuit in the antenna. Users can judge it from antenna status messages.

Table 10 ANT\_BIAS current range and antenna status

Antenna status	Status output	ANT_BIAS current range
Open circuit	OPEN	$0 < \text{ANT\_BIAS} \leq 1\text{mA}$
Regular circuit or open circuit	OK or OPEN	$1\text{mA} < \text{ANT\_BIAS} \leq 2\text{mA}$
Regular circuit	OK	$2\text{mA} < \text{ANT\_BIAS} \leq 40 \pm 5\text{mA}^{[1]}$
Short circuit	SHORT	$40 \pm 5\text{mA}^{[1]} < \text{ANT\_BIAS} < 55\text{mA}$

\* [1]  $\pm 5\text{mA}$  are differences between product batches.

**TIPs:**

1. Pulse width of the minimum detectable overshoot current should be more than 10uS.
2. NMEA message of antenna status output:
  - OPEN: \$GNTXT,01,01,01,**ANT\_OPEN**\*40
  - OK: \$GNTXT,01,01,01,**ANT\_OK**\*50
  - SHORT: \$GNTXT,01,01,01,**ANT\_SHORT**\*06

## 4.4 Reset and mode control

The operation mode of GNSS module is controlled by PRRSTX (nRESET) and PRTRG (BOOT) pin. While the module works in normal operation, leave PRRSTX and PRTRG pins floating if there is no system upgrading or reset demands.

- Keep PRTRG pin floating during system power-up or the external reset (PRRSTX from low to high), and the module will enter **User Normal Mode**.
- When the module powers up or PRRSTX from low to high, the module will execute an **external reset**. (If the power for AVDD\_BAK is always on, the external reset will not affect the ephemeris data in the backup domain)
- Drive PRTRG pin to low or connect PRTRG to GND directly (not by pull-down resistance) during system power-up or the external reset (PRRSTX from low to high), and the system enters **BootROM Command Mode** at PRTRG pin being released from low to floating state, and ready for firmware upgrading command.
- When connecting PRRSTX and PRTRG to any host IO, DO NOT use the pull-up or pull-down resistance.

## 4.5 Serial interfaces

### 4.5.1 Default message

**Table 11 Default message**

Interface	Settings
UART output	115200 baud, 8 data bits, no parity bit, 1 stop bit Configured to transmit both NMEA and HD Binary protocols, but only the following NMEA (and no HD Binary sentence) messages have been activated at start-up: GGA, GSA, GSV, RMC, ZDA, TXT-ANT
UART input	115200 baud, 8 data bits, no parity bit, 1 stop bit, autobauding disabled Automatically accepts following protocols without need of explicit configuration: HD binary sentence, NMEA, RTCM The GNSS receiver supports interleaved HD binary and NMEA messages.
Timepulse (1Hz Nav)	1 pulse per second, synchronized at rising edge, pulse length 100ms

\* Refer to *GNSS\_Protocol\_Specification* for information about other settings.

### 4.5.2 USB

USB version 2.0 FS compatible interface can be used for communication as an alternative to the UART.

- Supports USB 2.0 full speed
- Full Speed: 12Mbps
- Supports Windows XP/7/8/10 OS®

### 4.5.3 SPI

The Serial Peripheral Interface (SPI) supports SPI protocol. The SPI protocol is a full-duplex, synchronous and serial communication bus to external devices. Moreover, SPI supports master mode. SPI features:

- Full-duplex synchronous communication
- Master/slave mode is programmable
- The frequency of SPICK clock is programmable

### 4.5.4 I2C

The I2C interface is a serial input & output port, operating as a master & slave device.

- Master / Slave transmitting & receiving
- Speed support: 100Kps, 400Kps



## 5 MECHANICAL SPECIFICATION

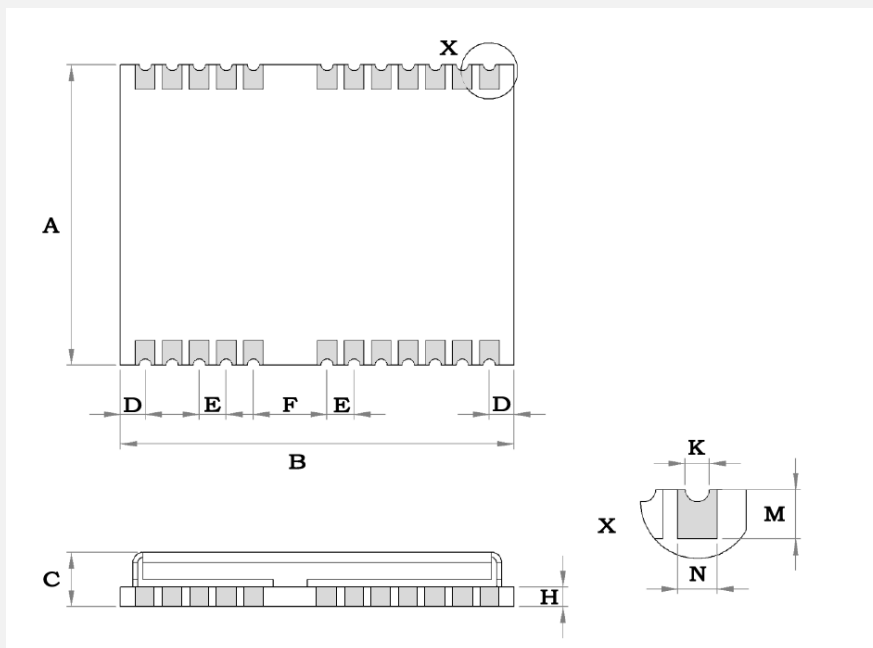

Figure 6 Dimensions

Table 12 Dimensions

Symbol	Min.(mm)	Typ.(mm)	Max.(mm)
A	12.0	12.2	12.4
B	15.8	16.0	16.2
C	2.2	2.4	2.6
D	0.9	1.0	1.3
E	1.0	1.1	1.2
F	2.9	3.0	3.1
H	--	0.8	--
K	0.4	0.5	0.6
M	0.8	0.9	1.0
N	0.7	0.8	0.9

## 6 REFERENCE DESIGN

### 6.1 Minimal Design

This is a minimal design for TAU1308 GNSS module as below. The 82nH inductor is used only when an active antenna is connected, and no need with a passive antenna. The characteristic impedance from RF\_IN pin to the antenna connector should be 50Ω.

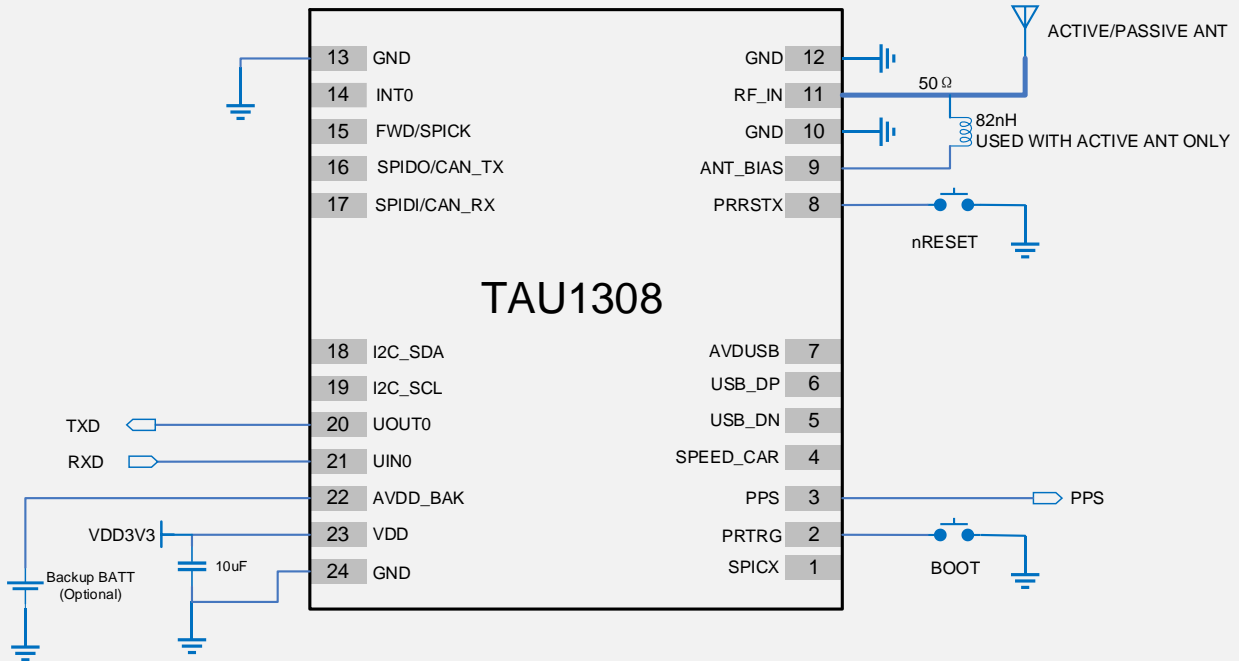

Figure 7 Minimal application diagram

### 6.2 PCB Footprint Reference

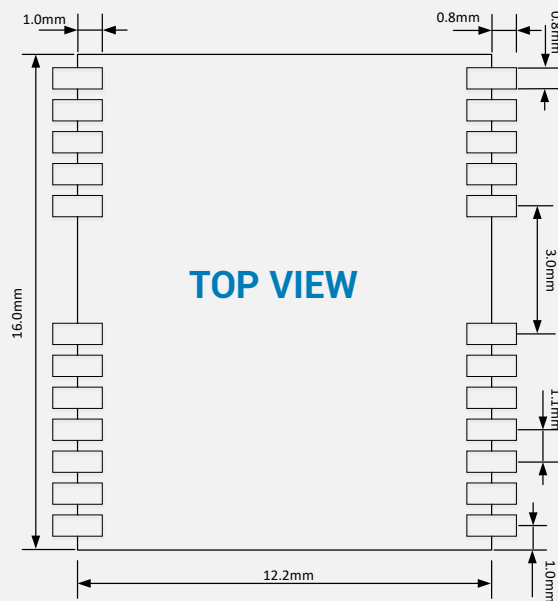

Figure 8 PCB Footprint Reference

### 6.3 Layout Notes

- (1) A decoupling capacitor should be placed close to VDD pin of the module, and the width of power routing should be more than 0.5mm;
- (2) The width of RF routing between RF port to antenna interface should be wider than 0.2mm. The characteristic impedance of RF routing between RF port to antenna interface should be controlled to 50Ω.
- (3) It is recommended that the routing from RF port to antenna interface refers to the second layer, and no routing are recommended on the layer.
- (4) Do not place the module close to any EMI source, like antenna, RF routing, DC/DC or power conductor, clock signal or other high-frequency switching signal, etc.





## 7 PRODUCT PACKAGING AND HANDLING

### 7.1 Packaging

#### 7.1.1 Packaging Notes

TAU1308 is a Moisture Sensitive Device (MSD) and Electrostatic Sensitive Device (ESD). During the packing and shipping, it is strictly required to take appropriate MSD handling instructions and precautions. The table below shows the general packing hierarchy for the standard shipment.

**Table 13 Packing hierarchy**

Module	Reel	Sealed bag	Shipping carton
			

#### 7.1.2 Tape and Reel

TAU1308 is delivered as hermetically sealed, reeled tapes in order to enable efficient production, production lot set-up and tear-down. The figure below shows the tape dimensions.

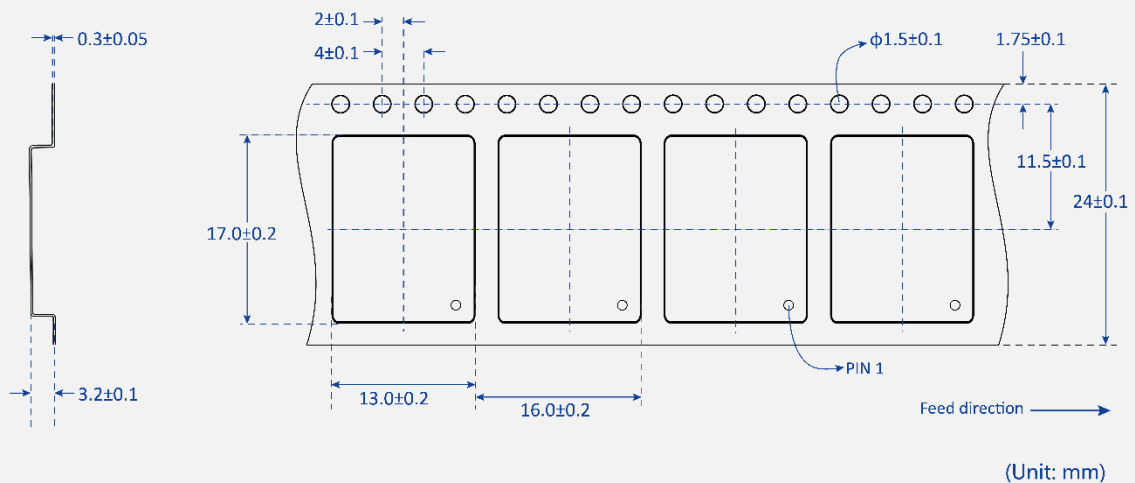

**Figure 9 Tape dimensions**

TAU1308 is deliverable in quantities of 1000pcs on a reel. The figure below shows the dimensions of reel for TAU1308.

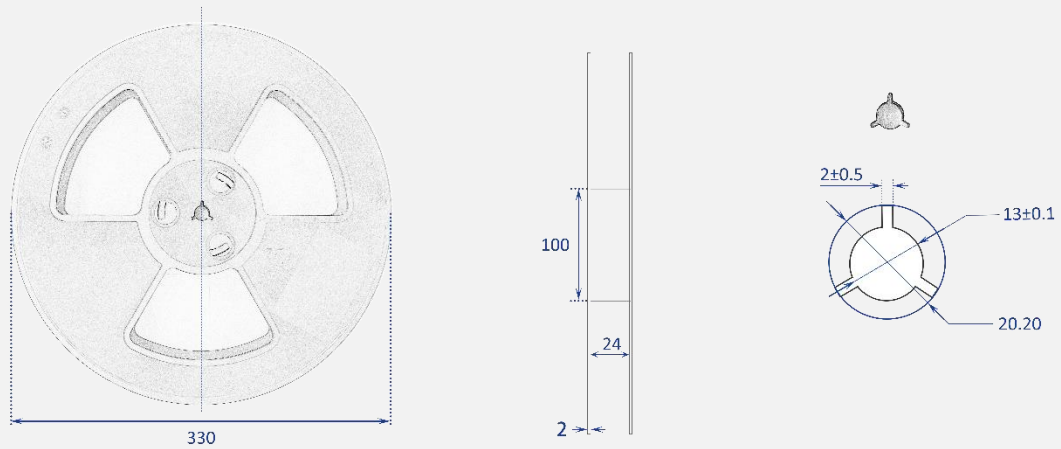

(Unit: mm)

**Figure 10 Reel dimensions**

### 7.1.3 Shipment Packaging

The reels of TAU1308 are packed in the sealed bags and shipped by shipping cartons. Up to five sealed bags (5000pcs in total) can be packed in one shipping carton.

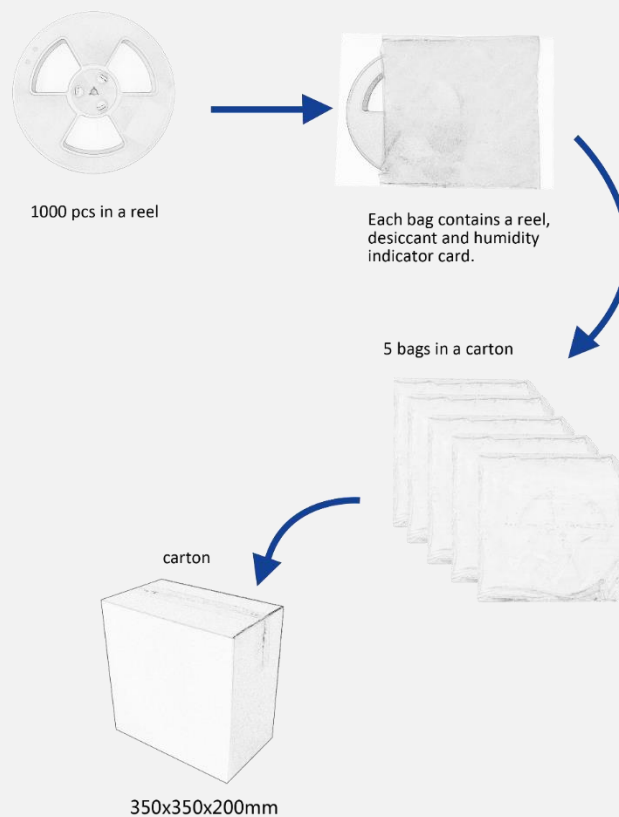

**Figure 11 Packaging**

## 7.2 Storage

In order to prevent moisture intake and protect against electrostatic discharge, TAU1308 is packaged together with a humidity indicator card and desiccant to absorb humidity.

## 7.3 ESD Handling

### 7.3.1 ESD Handling Precautions

TAU1308, which contains highly sensitive electronic circuitry, is an Electrostatic-sensitive Device (ESD). Observe precautions for handling! Failure to observe these precautions may result in severe damage to the GNSS module!

- Unless there is a galvanic coupling between the local GND (i.e. the workbench) and the PCB GND, then the first point of contact when handling the PCB must always be between the local GND and PCB GND.
- Before mounting an antenna patch, connect ground of the device.
- When handling the RF pin, do not come into contact with any charged capacitors and be careful when contacting materials that can develop charges (e.g. patch antenna ~10 pF, coax cable ~50 – 80 pF/m, soldering iron ...)
- To prevent electrostatic discharge through the RF input, do not touch any exposed antenna area. If there is any risk that such exposed antenna area is touched in non-ESD protected work area, implement proper ESD protection measures in the design.
- When soldering RF connectors and patch antennas to the receiver's RF pin, make sure to use an ESD safe soldering iron (tip).



### 7.3.2 ESD protection measures

The GNSS positioning module is sensitive to static electricity. Whenever handling the module, particular care must be exercised to reduce the risk of electrostatic charges. In addition to standard ESD safety practices, the following measures should be taken into account:

- 1) Adds ESD Diodes to the RF input part to prevent electrostatics discharge.
- 2) Do not touch any exposed antenna area.
- 3) Adds ESD Diodes to the UART interface.

### 7.3.3 Moisture sensitivity level

The Moisture Sensitivity Level (MSL) of the GNSS module is MSL4.

## 8 LABELING AND ORDERING INFORMATION

Labeling and ordering information help customers get more about Allystar products.

### 8.1 Labeling

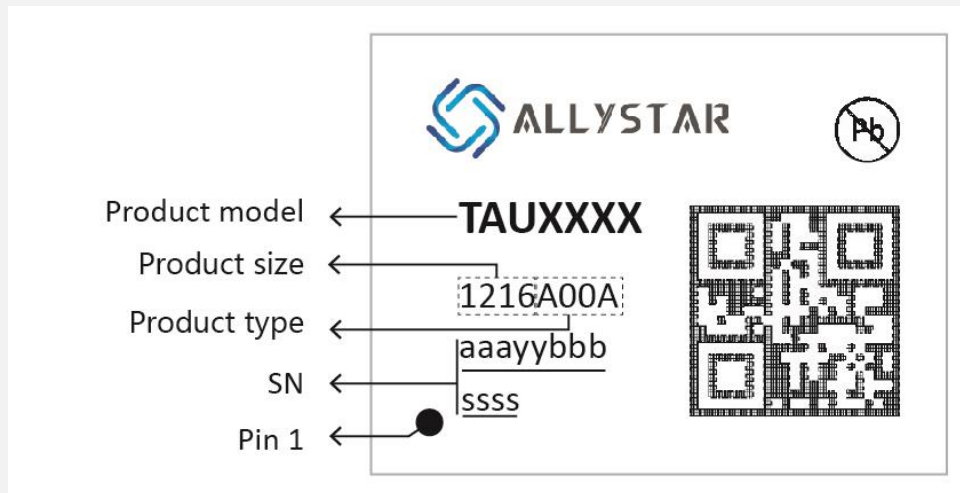

**Table 14 Labeling content**

Symbol	Explanation	Instance
TAUXXXX	Product model	TAU1308
1216A00A	1216 represents the product size.	1216A00
	A00 means the product type.	
	Second A refers to sales area code. Different code for different sales area.	E (for Europe market)
aaayybbbssss	Serial number	369190010001

### 8.2 Ordering info

**Table 15 Ordering codes**

Ordering No.	Product
TAU1308-1216A00E	Concurrent GNSS LCC Module, TCXO, ROM, 12.2*16mm, 1000 pieces/reel, Europe market.
TAU1308-1216A00H	Concurrent GNSS LCC Module, TCXO, ROM, 12.2*16mm, 1000 pieces/reel, India market.
TAU1308-1216A00R	Concurrent GNSS LCC Module, TCXO, ROM, 12.2*16mm, 1000 pieces/reel, Russia market.

## 9 RELATED DOCUMENTS

- [1] Satrack User Manual
- [2] Allystar Common Commands
- [3] Recommended Reflow Profile
- [4] GNSS\_Protocol\_Specification

## 10 REVISION HISTORY

Revision	Date	Reviser	Status / Comments
V1.0	2019-10-12	Vita Wu	Start version, first released
V1.1	2019-12-09	Vita Wu	Updates antenna gain in Section 4.2; Updates Section 6.3;
V1.2	2020-2-7	Vita Wu	Deletes RTK (V) position accuracy in Table 1; Updates the product name description in cover.
V1.3	2020-12	Vita Wu	<ol style="list-style-type: none"> <li>1. Updates MSL.</li> <li>2. Updates reference design;</li> <li>3. Updates operation power consumption;</li> <li>4. Updates sensitivity.</li> <li>5. Updates AVDD_BAK connectivity description in Section 4.1.</li> <li>6. Deletes SBAS support.</li> <li>7. Improves mechanical specification.</li> <li>8. Improves layout notes in Section 6.3.</li> <li>9. Clarifies power on/off sequence in Section 4.2.</li> <li>10. Deletes 1K resistor in the minimal design diagram.</li> <li>11. Localization.</li> <li>12. Other wordings improvements.</li> </ol>
V1.4	2021-07	Vita Wu	<p>Adds labeling and ordering info. Details default settings. Adds related document list. Adds document info section. Updates operative VDD to 2.0~3.6V. Adds power on/off sequence. Updates ANT_BIAS values.</p>





[www.allystar.com](http://www.allystar.com)



[info.gnss@allystar.com](mailto:info.gnss@allystar.com)



## Headquarters

Allystar Technology (Shenzhen) Co., Ltd.

Address: 201-2, 2F, Tower F, Xinghe World, No.1, Yabao Road, LongGang District, Shenzhen City, Guangdong Province, China.

## Calgary Office

Allystar Technology (Canada) Ltd.

Address: Unit 288, 3553 31 Street NW Calgary, Alberta, Canada T2L 2K7

