

FEATURES

1. Universal AC input 80~264VAC
2. Protections: Short circuit / Overload / Over voltage / Over temperature
3. 5"x3" miniature size
4. Refer to ANSI/AAMIES60601-1 and IEC/BSEN/EN60601-1 Medical Safety Certification(2xMOPP)
5. Cooling by free air convection for 250W and 420W with 25CFM forced air
6. No load power consumption < 0.5W by PS-ON control
7. 5Vdc standby, 12V fan supply, power good, power Fail and remote sense
8. Operated at an altitude of 5000 meters
9. 3 years warranty



**3 years
Warranty**

Specification

MODEL		RAOF420-20B12	RAOF420-20B15	RAOF420-20B24	RAOF420-20B27	RAOF420-20B36	RAOF420-20B48	
INPUT	VOLTAGE RANGE	80~264VAC (refer to 'static characteristic')						
	FREQUENCY RANGE	47~63Hz						
	POWER FACTOR	PF>0.94/230VAC		PF>0.98/115VAC at full load				
	EFFICIENCY(Typ.)	91.5%	92%	93%	93%	94%	94%	
	AC CURRENT(Typ.)	4.2A/115VAC 2.1A/230VAC						
	INRUSH CURRENT(Typ.)	35A/115VAC 70A/230VAC(cold start)						
	INRUSH CURRENT(Typ.)	Earth leakage current<200uA/264VAC 50Hz,touch current<70uA/264VAC						
OUTPUT	DC VOLTAGE	12V	15V	24V	27V	36V	48V	
	VOLTAGE ADJ.RANGE	11.4~12.6V	14.3~15.8V	22.8~25.2V	25.7~28.3V	34.2~37.8V	45.6~50.4V	
	RATED CURRENT	25CFM	35A	28A	17.5A	15.5A	11.6A	8.75A
		Convection	20.8A	16.7A	10.5A	9.3A	7A	5.3A
	RATED POWER	25CFM	420W	420W	420W	418.5W	417.6W	420W
		Convection	249.6W	250.5W	252W	251.1W	252W	254.4W
	RIPPLE&NOISE(max.)	120mVp-p	120mVp-p	150mVp-p	150mVp-p	200mVp-p	200mVp-p	
	VOLTAGE TOLERANCE	±3.0%	±3.0%	±2.0%	±2.0%	±1.0%	±1.0%	
	LINE REGULATION	±0.5%	±0.5%	±0.5%	±0.5%	±0.5%	±0.5%	
	LOAD REGULATION	±1.0%	±1.0%	±1.0%	±1.0%	±0.5%	±0.5%	
SETUP,RISE TIME	1000ms,50ms/230VAC		1500ms,50ms/115VAC at full load					
HOLD UP TIME(Typ.)	10ms/230VAC		10ms/115VAC at full load					
PROTECTION	OVER LOAD	105-135%rated output power Protection type:Hiccup mode,recovers automatically after fault condition is removed						
	OVER VOLTAGE	13.2~15.6V	16.5~19.5V	26.4~31.2V	29.7~35.1V	39.6~46.8V	52.8~62.4V	
		Protection type:shut down,recovers after repower on						
	OVER TEMPERATURE	Protection type:shut down,recovers automatically after fault condition is removed						
FUNCTION	5V STANDBY	5Vsb:5V@0.6A without fan,1A with fan 25CFM;tolerance 2%,ripple:150mVp-p(max.)						
	FAN SUPPLY	12V@0.5A for driving a fan;Tolerance-15%~-+10%at main output 35%rated current						
	REMOTE SENSE	When RS+and RS-are connected to the client,they have a remote voltage compensation effect						
	PS-ON INPUT SIGNAL	Power on:PS-ON="Hi"or"2~5V";Power off:PS-ON="Low"or"0~0.5V"						
	POWER GOOD/POWER FAIL	500ms>PG>10ms;The TTL signal goes high with 10ms to 500ms delay after power set up; The TTL signal goes low at least 1ms before Vo below 90%of rated value						

ENVIRONMENT	WORKING TEMP	-30~+70°C(Refer to"Derating curve")		
	WORKING TEMP,HUMIDITY	20~90%RH,non-condensing		
	WORKING HUMIDITY	-40~+85°C,10~95%RH,non-condensing		
	TEMP.COEFFICIENT	±0.03%(0~50°C)		
	VIBRATION	10-500Hz,2G10min./1 cycle,each along X、 Y、 Z axes		
	OPERATING ALTITUDE	5000m		
Safety and electromagnetic compatibility	Safety standards	Refer to UL62368-1,TUV EN62368-1,CCC GB4943.1,EN60601-1(2XMOPP)		
	Withstand voltage and isolation resistance	I/P-O/P:4KVac;100MΩ/500Vdc	/25°C/70%RH	
		I/P-FG:2KVac;100MΩ/500Vdc	/25°C/70%RH	
		O/P-FG:1.5KVac;100MΩ/500Vdc	/25°C/70%RH	
	Electromagnetic compatibility emission	Parameter	Standard	Test Level /Note
		Conducted emission	BS EN/EN55032(CISPR32),FCC PART 15/CISPR22,GB9254.1	Class B
		Radiated emission	BS EN/EN55032(CISPR32),FCC PART 15/CISPR22,GB9254.1	Class B
		Harmonic current	BS EN/EN61000-3-2,GB17625.1	Class A
		Voltage flicker	BS EN/EN61000-3-3	
	Electromagnetic compatibility immunity	BS EN/EN55035		
		Parameter	Standard	Test Level /Note
		ESD	BS EN/EN61000-4-2	Level 4,8KV air,Level 2,4KV contact,criteria A
RF field susceptibility		BS EN/EN61000-4-3	Level 3,criteria A	
EFT bursts		BS EN/EN61000-4-4	Level 3,criteria A	
Surge susceptibility		BS EN/EN61000-4-5	Level 4,2KV/L-N,4KV/L/N-FG	
Conducted susceptibility		BS EN/EN61000-4-6	Level 3,criteria A	
Magnetic field immunity		BS EN/EN61000-4-8	Level 4,criteria A	
Voltage dips and interruptions	BS EN/EN61000-4-11	>95%dip 0.5 periods,30%dip 25 periods,>95%interruptions 250 periods		
OTHERS	DIMENSION	PCB:127*76.2*35.5mm(L*W*H)		
	PACKING	0.37Kg;36pcs/14.3Kg/0.96CUFT		
NOTE	<p>1.All parameters NOT specially mentioned are measured at 230VAC input,rated load and 25°C of ambient temperature</p> <p>2.Ripple & noise are measured at 20MHz of bandwidth by using a 12"twisted pair-wire terminated with a 0.1uF&47uF parallel capacitor</p> <p>3.Tolerance:includes set up tolerance,line regulation and load regulation.</p> <p>4.Line regulation is measured from low line to high line at rated load.</p> <p>5.Load regulation is measured from 0% to 100% rated load</p> <p>6.Length of set up time is measured at cold first start,Turning ON/OFF the power supply very quickly may lead to increase of the set up time.</p> <p>7.The ambient temperature derating of 5°C/1000m is needed for operating altitude great than 2000m(6500ft)</p> <p>8.The power supply is considered a component which will be installed into a final equipment. All the EMC tests are been executed by mounting the unit on a 360mm*360mm metal plate with 1mm of thickness.The final equipment must be re-confirmed that it still meets EMC directives</p>			

Block diagram

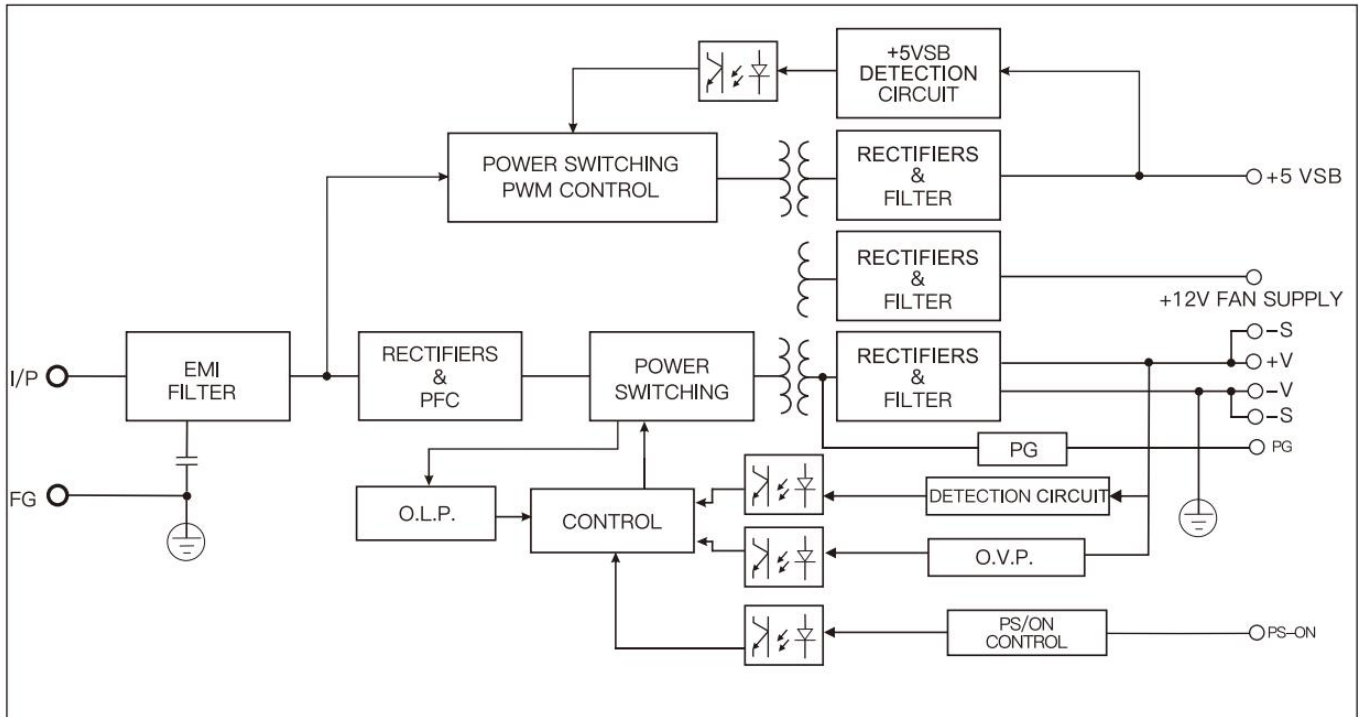

Derating curve

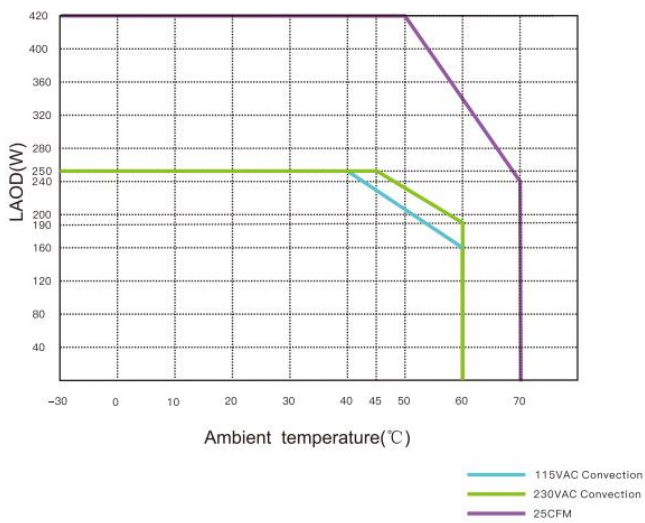

Static characteristics

