



**Preliminary Specification**  
**Final Specification**

|                   |                               |
|-------------------|-------------------------------|
| <b>Module</b>     | <b>5.7 Inch Color TFT-LCD</b> |
| <b>Model Name</b> | <b>G057VTN01.0</b>            |

| <b>Customer</b>                  | <b>Date</b> |
|----------------------------------|-------------|
| _____                            | _____       |
| <b>Checked &amp; Approved by</b> |             |
| _____                            | _____       |

Note: This Specification is subject to change without notice.

| <b>Approved by</b>  | <b>Date</b>       |
|---------------------|-------------------|
| <u>Leader Feng</u>  | <u>2012/03/05</u> |
| <b>Prepared by</b>  |                   |
| <u>Shiyen Cheng</u> | <u>2012/03/01</u> |

General Display Business Division / AU Optronics corporation

AUO Confidential For PROMATE Internal Use Only On 2015/01/09

## Contents

|   |    |
|---|----|
| 1. Operating Precautions .....                                  | 4  |
| 2. General Description .....                                    | 5  |
| 2.1 Display Characteristics .....                               | 5  |
| 2.2 Optical Characteristics .....                               | 6  |
| 3. Functional Block Diagram .....                               | 8  |
| 4. Absolute Maximum Ratings .....                               | 9  |
| 4.1 Absolute Ratings .....                                      | 9  |
| 4.2 Absolute Ratings of Environment .....                       | 9  |
| 5. Electrical Characteristics .....                             | 10 |
| 5.1 TFT-LCD Driving .....                                       | 10 |
| 5.2 Backlight Unit Driving .....                                | 11 |
| 6. Signal Characteristic .....                                  | 11 |
| 6.1 Pixel Format Image .....                                    | 11 |
| 6.2 Scanning Direction .....                                    | 12 |
| 6.3 The Input Data Format .....                                 | 12 |
| 6.4 TFT- LCD Interface Signal Description .....                 | 13 |
| 6.5 TFT- LCD Interface Timing .....                             | 15 |
| 6.6 LED Backlight Unit Interface Signal Description .....       | 16 |
| 6.7 Power ON/OFF Sequence .....                                 | 16 |
| 7. Connector & Pin Assignment .....                             | 17 |
| 7.1 TFT- LCD Signal (CN1): LCD Connector .....                  | 17 |
| 7.2 LED Backlight Unit (CN2): Backlight Connector .....         | 17 |
| 7.3 LED Light Bar Input (CN3): Light Bar Connector .....        | 18 |
| 7.4 PIN 1 definition of CN1 and CN2 .....                       | 19 |
| 8. Reliability Test Criteria .....                              | 20 |
| 9. Mechanical Characteristics .....                             | 21 |
| 10. Label and Packaging .....                                   | 22 |
| 10.1 Shipping Label (on the rear side of TFT-LCD display) ..... | 22 |
| 10.2 Carton Package .....                                       | 22 |
| 11 Safety .....   | 23 |
| 11.1 Keen Edge Requirements .....                               | 23 |
| 11.2 Materials .....  | 23 |
| 11.3 Capacitors .....   | 23 |
| 11.4 National Test Lab Requirement .....                        | 23 |

## Record of Revision

| Version and Date                 | Page       | Old description         | New Description   | Remark |
|----------------------------------|------------|-------------------------|---|--------|
| V 0.1<br>Mar, 01, 2012           | All        | Copied from G057VN01 V2 | First edition preliminary specifications                                |        |
| V 1.0 Final Spec<br>Oct 17, 2012 | 6<br>17.18 |                         | 1. Color/Chromaticity Coordinates defined<br>2. Connector model updated |        |
| V 1.1 Dec 11,<br>2014            | 11         |                         | Parameter guideline for LED   |        |

AUO Confidential For PROMATE Internal Use Only On 2015/01/09

## 1. Operating Precautions

- 1) Display area (Polarizer) of TFT-LCD Module is easily to be damaged, please be cautious and not to scratch it.
- 2) Be sure to power off your machine before connecting or disconnecting your signal cable to TFT-LCD Module.
- 3) Wipe off water drop on display area immediately. Long contact with water may cause discoloration or spots.
- 4) When the panel surface is soiled, wipe it with absorbent cotton or soft cloth.
- 5) Display area (Glass) of TFT-LCD Module may be broken or cracked if bump Module against hard object.
- 6) To avoid ESD (Electro Static Discharge) damage, be sure to ground yourself before handling TFT-LCD Module.
- 7) Do not open nor modify the TFT-LCD module assembly.
- 8) Do not press the reflector sheet at the back of the module to any direction.
- 9) In case if TFT-LCD module has to be put back into the packing container slot after it was taken out from the container, do not press the center of the LED Reflector edge. Instead, press at the far ends of the LED Reflector edge softly. Otherwise the TFT-LCD Module may be damaged.
- 10) When inserting or removing of your signal cable to TFT-LCD Module, be sure not to apply abnormal force (rotate, tilt...etc.) to the Connector of the TFT-LCD Module.
- 11) TFT-LCD Module is not allowed to be twisted & bent even force is added on module in a very short time. Please design your display product well to avoid external force applying to module by end-user directly.
- 12) Small amount of materials without flammability grade are used in the TFT-LCD module. The TFT-LCD module should be supplied by power complied with requirements of Limited Power Source (IEC60950 or UL1950), or be applied exemption.
- 13) Severe temperature condition may result in different luminance, response time.
- 14) Continuous operating TFT-LCD Module under high temperature environment may accelerate LED light bar exhaustion and reduce luminance dramatically.
- 15) The data on this specification sheet is applicable when TFT-LCD module is placed in landscape position.
- 16) Continuous displaying fixed pattern may induce image sticking. It's recommended to use screen saver or moving content periodically if fixed pattern is displayed on the screen.

## 2. General Description

G057VTN01.0 is designed for industrial display applications with VGA (640 x RGB x 480) resolution and 262k colors (RGB 6-bits). It is composed of a TFT-LCD panel, driver ICs, control and power supply circuits board and backlight unit including LED driver circuit. G057VTN01.0 offers CMOS interface for display signal input.

### 2.1 Display Characteristics

The following items are G057VTN01.0 characteristics summary at 25 °C (Room Temperature).

| Items                        | Unit  | Specifications  |
|------------------------------|-------|---|
| Screen Diagonal              | inch  | 5.7   |
| Active Area                  | mm    | 115.2(H) x 86.4(V)  |
| Pixels H x V                 |       | 640 x 3(RGB) x 480  |
| Pixel Pitch                  | mm    | 0.18 x 0.18   |
| Pixel Arrangement            |       | R.G.B. Vertical Stripe  |
| Display Mode                 |       | TN, Normally White  |
| Nominal Input Voltage VDD    | Volt  | 3.3 typ.  |
| Typical Power Consumption    | Watt  | 3.62W (LCD:0.5W/LED BLU: 3.12W)<br>@ All black pattern, Full Load and V <sub>LED</sub> =12V |
| Weight                       | Grams | 150g (typ.), 165g (max.)  |
| Physical Size                | mm    | 144.0(H)x 104.6(V) x 12.3(D) (typ.)   |
| Electrical Interface         |       | CMOS 6-bit Parallel RGB   |
| Surface Treatment            |       | Anti-Glare, Hardness 3H   |
| Support Color                |       | 262K colors   |
| The most suitable view angle |       | 12 o'clock  |
| Temperature Range            |       |   |
| Operating                    | °C    | -30 to +85  |
| Storage (Non-Operating)      | °C    | -30 to +85  |
| RoHS Compliance              |       | RoHS Compliance   |

## 2.2 Optical Characteristics

The optical characteristics are measured under stable conditions at 25 (Room Temperature).

| Item  | Unit              | Conditions  | Min.     | Typ.     | Max.   | Remark       |
|---|-------------------|---|----------|----------|--------|--------------|
| White Luminance                             | cd/m <sup>2</sup> | V <sub>LED</sub> = 12V, D <sub>PWM</sub> = 100%<br>(center point) | 400      | 530      | -      | Note 1       |
| Uniformity                                  | %                 | 5 Points  |          | -        | 1.3    | Note 1, 2, 3 |
| Contrast Ratio                              |                   |   | 500      | 800      | -      | Note 4       |
| Response Time                               | msec              | Rising  | -        | 15       | 20     | Note 5       |
|   | msec              | Falling   | -        | 10       | 15     |              |
|   | msec              | Rising + Falling  | -        | 25       | 35     |              |
| Viewing Angle                               | degree<br>degree  | Horizontal (Right)<br>CR = 10 (Left)                              | 70<br>70 | 80<br>80 | -<br>- | Note 6       |
|   | degree<br>degree  | Vertical (Upper)<br>CR = 10 (Lower)                               | 60<br>60 | 70<br>70 | -<br>- |              |
| Color / Chromaticity Coordinates (CIE 1931) |                   | White x   | 0.263    | 0.313    | 0.363  |              |
|   |                   | White y   | 0.279    | 0.329    | 0.379  |              |
|   |                   | Red x   | 0.491    | 0.541    | 0.591  |              |
|   |                   | Red y   | 0.263    | 0.313    | 0.363  |              |
|   |                   | Green x   | 0.277    | 0.327    | 0.377  |              |
|   |                   | Green y   | 0.549    | 0.599    | 0.649  |              |
|   |                   | Blue x  | 0.108    | 0.158    | 0.208  |              |
|   |                   | Blue y  | 0.075    | 0.125    | 0.175  |              |
| Color Gamut                                 | %                 |   | -        | 50       | -      |              |

Note 1: Measurement method

Equipment Pattern Generator, Power Supply, Digital Voltmeter, Luminance meter (SR\_3 or equivalent)

Aperture 1° with 50cm viewing distance

Test Point Center

Environment < 1 lux

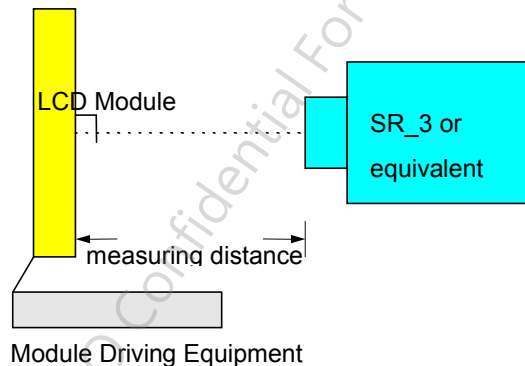

Note 2: Definition of 5 points position (Display active area: 115.2mm(W) x 86.4mm(H))

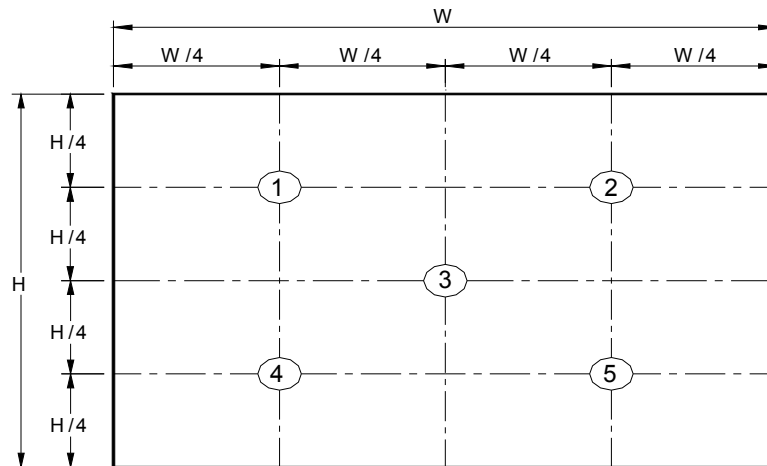

Note 3:

The luminance uniformity of 5 points is defined by dividing the maximum luminance value by the minimum luminance value at full white condition.

$$w_5 = \frac{\text{Maximum Brightness of five points}}{\text{Minimum Brightness of five points}}$$

Note 4: Definition of contrast ratio (CR):

$$\text{Contrast ratio (CR)} = \frac{\text{Brightness @ "White" state}}{\text{Brightness @ "Black" state}}$$

Note 5: Definition of response time:

The output signals of photo detector are measured when the input signals are changed from "White" to "Black" (falling time) and from "Black" to "White" (rising time), respectively. The response time interval definition is between 10% and 90% of amplitude. Please refer to the figure as below.

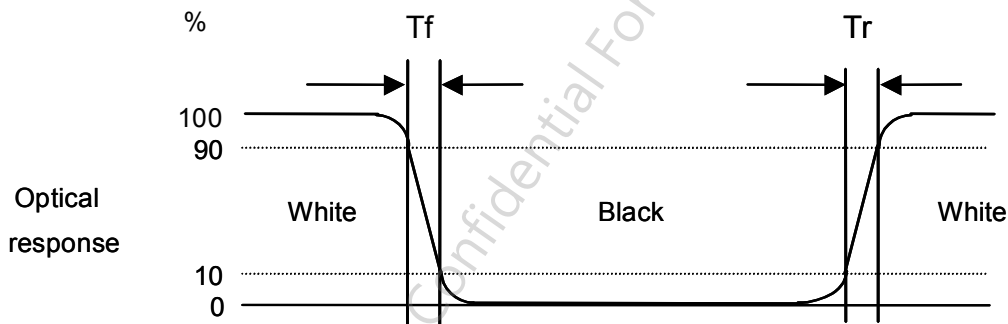

Note 6: Definition of viewing angle

Viewing angle is the measurement of contrast ratio 10, at the screen center, over 180° horizontal and 180° vertical range. The 180° horizontal ( $\theta_L$ ,  $\theta_R$ ) and 180° vertical ( $\phi_H$ ,  $\phi_L$ ) range are illustrated as following figure.

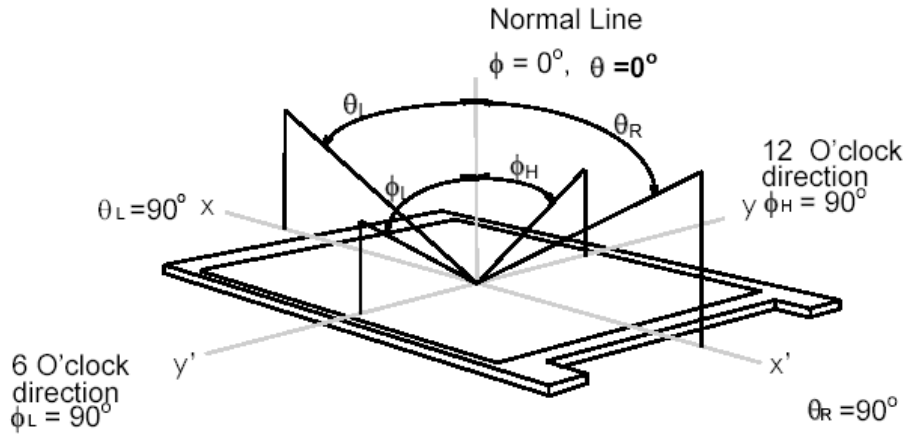

### 3. Functional Block Diagram

The following diagram shows the functional block of the G057VTN01.0 color TFT/LCD module.

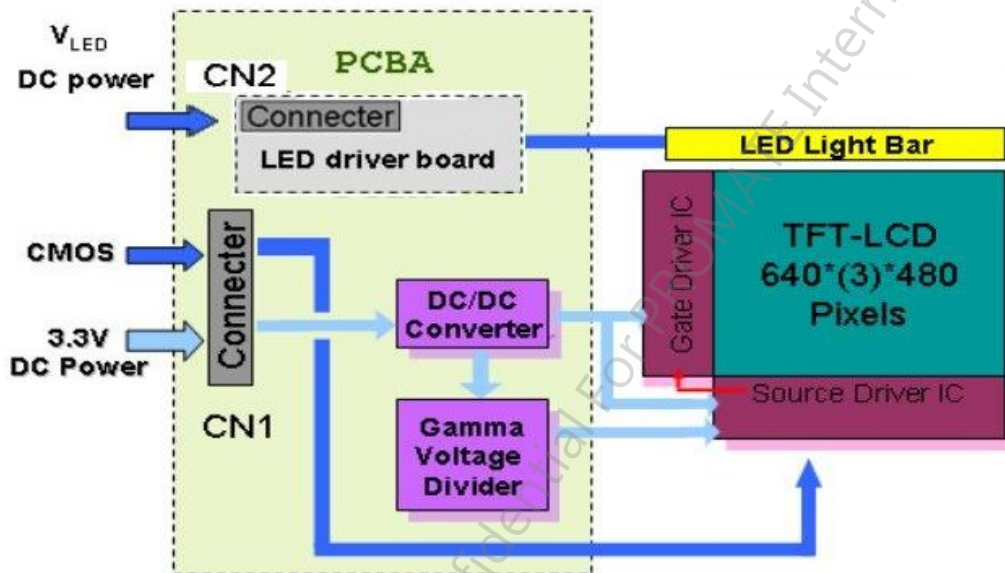



## 4. Absolute Maximum Ratings

### 4.1 Absolute Ratings

| Item                       | Symbol                  | Min   | Max   | Unit | Remark   |
|----------------------------|-------------------------|-------|-------|------|----------|
| Logic/LCD Drive Voltage    | VDD                     | - 0.3 | + 5.0 | Volt | Ta= 25°C |
| LCD Input Signal Voltage   | VIN                     | - 0.3 | + 5.0 | Volt | Ta= 25°C |
| LED BLU Drive Voltage      | V <sub>LED</sub>        | 0     | 23    | Volt | Ta= 25°C |
| LED On/Off Control Voltage | V <sub>LED On/Off</sub> | 0     | 20    | Volt | Ta= 25°C |
| LED Dimming Input Voltage  | V <sub>PWM</sub>        | 0     | 8     | Volt | Ta= 25°C |

### 4.2 Absolute Ratings of Environment

| Item                  | Symbol | Min | Max | Unit | Remark    |
|-----------------------|--------|-----|-----|------|-----------|
| Operating Temperature | TOP    | -30 | +85 |      | Note 1, 2 |
| Operation Humidity    | HOP    | 5   | 95  | %RH  | Note 1, 2 |
| Storage Temperature   | TST    | -30 | +85 |      | Note 1    |
| Storage Humidity      | HST    | 5   | 95  | %RH  | Note 1    |

Note 1: Maximum Wet-Bulb should be 39 and no condensation.

Note 2: Only operation is guaranteed. Optical performance should be evaluated at 25 only.

## 5. Electrical Characteristics

### 5.1 TFT-LCD Driving

#### 5.1.1 Power Specification

| Symbol | Parameter                                | Min | Typ | Max  | Units | Remark                                |
|--------|--|-----|-----|------|-------|---------------------------------------|
| VDD    | Logic/LCD Drive Voltage                  | 3.0 | 3.3 | 3.6  | Volt  |                                       |
| IDD    | VDD Current                              | -   | 150 | 165  | mA    | All Black Pattern (VDD=3.3V, at 60Hz) |
| PDD    | VDD Power                                | -   | 0.5 | 0.55 | Watt  | All Black Pattern (VDD=3.3V, at 60Hz) |
| VDDrp  | Allowable Logic/LCD Drive Ripple Voltage | -   | -   | 100  | mVp-p | All Black Pattern (VDD=3.3V, at 60Hz) |

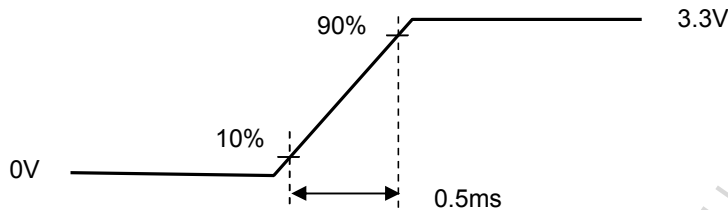

VDD rising time

#### 5.1.2 Signal Electrical Characteristics

Input signals shall be low or Hi-Z state when VDD is off.

| Parameter                               | Symbol | Min.            | Typ.   | Max. | Unit   | Remarks |
|---|--------|-----------------|--------|------|--------|---------|
| Logic Input Voltage for Display Signals | High   | V <sub>IH</sub> | 0.7VDD | -    | VDD    | Volt    |
|   | Low    | V <sub>IL</sub> | 0      | -    | 0.3VDD | Volt    |
| Input Voltage for RL/UD                 | High   | V <sub>IH</sub> | 0.7VDD | -    | VDD    | Volt    |
|   | Low    | V <sub>IL</sub> | 0      | -    | 0.3VDD | Volt    |

## 5.2 Backlight Unit Driving

### 5.2.1 Parameter guideline for LED

Following characteristics are measured under stable condition using a LED driving board at 25 (Room Temperature)

| Symbol            | Parameter                    | Min   | Typ  | Max   | Units | Remark                           |
|-------------------|------------------------------|-------|------|-------|-------|----------------------------------|
| $V_{LED}$         | Input Voltage                | 9     | 12   | 20    | Volt  |                                  |
| $I_{LED}$         | Input Current                | -     | 0.26 | 0.286 | A     | $V_{LED} = 12V, D_{PWM} = 100\%$ |
| $P_{LED}$         | Power Consumption            | 2.24  | 3.12 | 3.43  | Watt  | $V_{LED} = 12V, D_{PWM} = 100\%$ |
| $V_{PWM\ DIM}$    | Dimming control Voltage High | 2.0   | 3.3  | 5.0   | Volt  | Note 1,2                         |
|                   | Dimming control Voltage Low  | -     | -    | 0.2   | Volt  |                                  |
| $F_{PWM}$         | Dimming Frequency            | 200   | -    | 30K   | Hz    |                                  |
| $D_{PWM}$         | Dimming duty cycle           | 1     | -    | 100   | %     |                                  |
| $V_{LED\ On/Off}$ | On Control Voltage           | 2     | 3.3  | 5.5   | Volt  | Note 3, 4                        |
|                   | Off Control Voltage          | -     | -    | 0.8   | Volt  |                                  |
| $I_F$             | LED Forward Current          |       | 80   |       | mA    | $T_a = 25^{\circ}C$              |
| $V_F$             | LED Forward Voltage          |       | 32   | 40.0  |       | $I_F = 80mA, T_a = 25^{\circ}C$  |
| $P_{LED}$         | LED Power                    |       | 2.56 | 3.2   | Watt  |                                  |
| Operating Life    |                              | 50000 | -    | -     | Hrs   | Note 5, 6                        |

Note 1: PWM dimming function can be operated by PWM signal. PWM duty cycle can adjust white Luminance.

(PWM High: ON and PWM Low: OFF)

Note 2: PWM signal can not be floating and pull-down to ground when waiting.

Note 3: Enable ( $V_{LED\ On/Off}$ ) must be turned on late than  $V_{LED}$  and PWM Signal.

Note 4: Enable ( $V_{LED\ On/Off}$ ) must be turned off early than  $V_{LED}$  and PWM Signal.

Note 5: If G057VTN01.0 module is driven by high current or at high ambient temperature & humidity condition. The operating life will be reduced.

Note 6: Operating life means brightness goes down to 50% initial brightness. Minimum operating life time is estimated data.

Note 7: See Section 6.6 for LED Backlight Unit Interface Signal Description

## 6. Signal Characteristic

### 6.1 Pixel Format Image

Following figure shows the relationship between input signal and LCD pixel format.

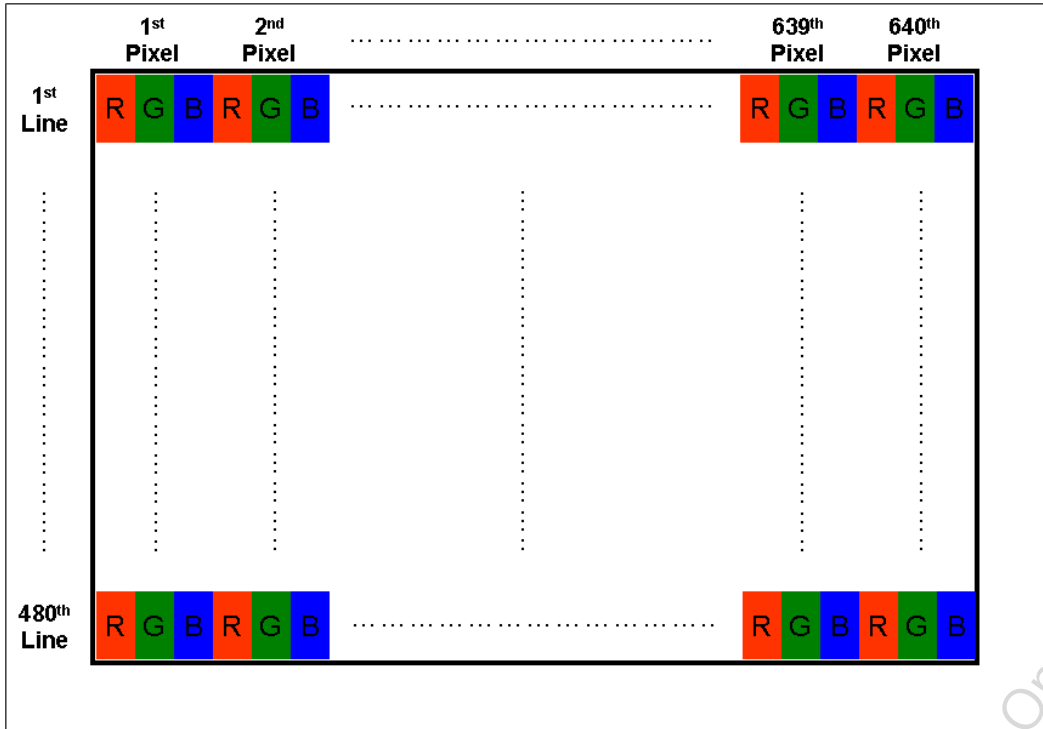

## 6.2 Scanning Direction

The following figures show the image seen from the front view. The arrow indicates the direction of scan.

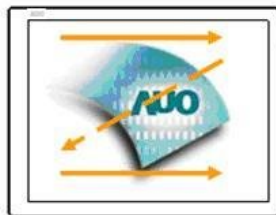

R/L=Low or NC; U/D=High or NC

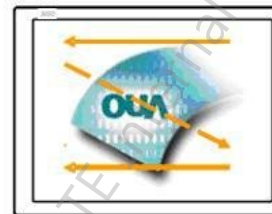

R/L=High; U/D=High or NC

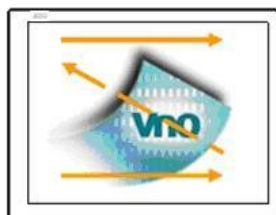

R/L=Low or NC; U/D=Low



R/L=High; U/D=Low

**Note 1: TFT-LCD interface signal description is shown in section 6.4.**

## 6.3 The Input Data Format

This product displays 262,144 colors in terms of the 64 grey levels on RGB respectively. The following table demonstrates the display of input data.

| Display colors  |         | Data signal (0 : Low level, 1: High level) |    |    |    |    |    |    |    |    |    |    |    |    |    |    |    |    |    |
|-----------------|---------|--|----|----|----|----|----|----|----|----|----|----|----|----|----|----|----|----|----|
|                 |         | R5   | R4 | R3 | R2 | R1 | R0 | G5 | G4 | G3 | G2 | G1 | G0 | B5 | B4 | B3 | B2 | B1 | B0 |
| Basic colors    | Black   | 0  | 0  | 0  | 0  | 0  | 0  | 0  | 0  | 0  | 0  | 0  | 0  | 0  | 0  | 0  | 0  | 0  | 0  |
|                 | Blue    | 0  | 0  | 0  | 0  | 0  | 0  | 0  | 0  | 0  | 0  | 0  | 0  | 1  | 1  | 1  | 1  | 1  | 1  |
|                 | Red     | 1  | 1  | 1  | 1  | 1  | 1  | 0  | 0  | 0  | 0  | 0  | 0  | 0  | 0  | 0  | 0  | 0  | 0  |
|                 | Magenta | 1  | 1  | 1  | 1  | 1  | 1  | 0  | 0  | 0  | 0  | 0  | 0  | 1  | 1  | 1  | 1  | 1  | 1  |
|                 | Green   | 0  | 0  | 0  | 0  | 0  | 0  | 1  | 1  | 1  | 1  | 1  | 1  | 0  | 0  | 0  | 0  | 0  | 0  |
|                 | Cyan    | 0  | 0  | 0  | 0  | 0  | 0  | 1  | 1  | 1  | 1  | 1  | 1  | 1  | 1  | 1  | 1  | 1  | 1  |
|                 | Yellow  | 1  | 1  | 1  | 1  | 1  | 1  | 1  | 1  | 1  | 1  | 1  | 1  | 0  | 0  | 0  | 0  | 0  | 0  |
|                 | White   | 1  | 1  | 1  | 1  | 1  | 1  | 1  | 1  | 1  | 1  | 1  | 1  | 1  | 1  | 1  | 1  | 1  | 1  |
| Red grayscale   | Black   | 0  | 0  | 0  | 0  | 0  | 0  | 0  | 0  | 0  | 0  | 0  | 0  | 0  | 0  | 0  | 0  | 0  | 0  |
|                 | Dark    | 0  | 0  | 0  | 0  | 0  | 1  | 0  | 0  | 0  | 0  | 0  | 0  | 0  | 0  | 0  | 0  | 0  | 0  |
|                 | ↑       |  |    |    |    |    |    |    |    |    |    |    |    |    |    |    |    |    |    |
|                 | ↓       |  |    |    |    |    |    |    |    |    |    |    |    |    |    |    |    |    |    |
|                 | bright  | 1  | 1  | 1  | 1  | 0  | 1  | 0  | 0  | 0  | 0  | 0  | 0  | 0  | 0  | 0  | 0  | 0  | 0  |
|                 | Red     | 1  | 1  | 1  | 1  | 1  | 0  | 0  | 0  | 0  | 0  | 0  | 0  | 0  | 0  | 0  | 0  | 0  | 0  |
| Green grayscale | Black   | 0  | 0  | 0  | 0  | 0  | 0  | 0  | 0  | 0  | 0  | 0  | 0  | 0  | 0  | 0  | 0  | 0  | 0  |
|                 | Dark    | 0  | 0  | 0  | 0  | 0  | 0  | 0  | 0  | 0  | 0  | 1  | 0  | 0  | 0  | 0  | 0  | 0  | 0  |
|                 | ↑       |  |    |    |    |    |    |    |    |    |    |    |    |    |    |    |    |    |    |
|                 | ↓       |  |    |    |    |    |    |    |    |    |    |    |    |    |    |    |    |    |    |
|                 | bright  | 0  | 0  | 0  | 0  | 0  | 0  | 1  | 1  | 1  | 1  | 0  | 1  | 0  | 0  | 0  | 0  | 0  | 0  |
|                 | Green   | 0  | 0  | 0  | 0  | 0  | 0  | 1  | 1  | 1  | 1  | 1  | 1  | 0  | 0  | 0  | 0  | 0  | 0  |
| Blue grayscale  | Black   | 0  | 0  | 0  | 0  | 0  | 0  | 0  | 0  | 0  | 0  | 0  | 0  | 0  | 0  | 0  | 0  | 0  | 0  |
|                 | Dark    | 0  | 0  | 0  | 0  | 0  | 0  | 0  | 0  | 0  | 0  | 0  | 0  | 0  | 0  | 0  | 0  | 0  | 1  |
|                 | ↑       |  |    |    |    |    |    |    |    |    |    |    |    |    |    |    |    |    |    |
|                 | ↓       |  |    |    |    |    |    |    |    |    |    |    |    |    |    |    |    |    |    |
|                 | bright  | 0  | 0  | 0  | 0  | 0  | 0  | 0  | 0  | 0  | 0  | 0  | 0  | 1  | 1  | 1  | 1  | 0  | 1  |
|                 | Blue    | 0  | 0  | 0  | 0  | 0  | 0  | 0  | 0  | 0  | 0  | 0  | 0  | 1  | 1  | 1  | 1  | 1  | 1  |

6.4 TFT- LCD Interface Signal Description

| PIN No. | Symbol | Pin Description   |
|---------|--------|---|
| 1       | GND    | Ground  |
| 2       | DOTCLK | Dot clock   |
| 3       | NC     | NC  |
| 4       | NC     | NC  |
| 5       | GND    | Ground  |
| 6       | R0     | Red data (LSB)  |
| 7       | R1     | Red data  |
| 8       | R2     | Red data  |
| 9       | R3     | Red data  |
| 10      | R4     | Red data  |
| 11      | R5     | Red data (MSB)  |
| 12      | GND    | Ground  |
| 13      | G0     | Green data (LSB)  |
| 14      | G1     | Green data  |
| 15      | G2     | Green data  |
| 16      | G3     | Green data  |
| 17      | G4     | Green data  |
| 18      | G5     | Green data (MSB)  |
| 19      | GND    | Ground  |
| 20      | B0     | Blue data (LSB)   |
| 21      | B1     | Blue data   |
| 22      | B2     | Blue data   |
| 23      | B3     | Blue data   |
| 24      | B4     | Blue data   |
| 25      | B5     | Blue data (MSB)   |
| 26      | GND    | Ground  |
| 27      | DE     | Data Enable Signal  |
| 28      | VDD    | Power supply (3.3V Typ. ONLY)   |
| 29      | VDD    | Power supply (3.3V Typ. ONLY)   |
| 30      | R/L    | Horizontal reverse scan<br>(Low or NC → Normal, High → Right & Left Reverse Scan) |
| 31      | U/D    | Vertical reverse scan<br>(High or NC → Normal, Low → Up & Down Reverse Scan)      |
| 32      | NC     | NC  |
| 33      | GND    | Ground  |

Note 1: "Low" stands for 0V. "High" stands for 3.3V. "NC" stands for "No Connection".

## 6.5 TFT- LCD Interface Timing

### 6.5.1 Timing Characteristics

DE mode only

| Signal                   | Symbol        | Min.      | Typ. | Max. | Unit | Remark      |               |
|--------------------------|---------------|-----------|------|------|------|-------------|---------------|
| Clock frequency (DOTCLK) | $1/T_{CLOCK}$ | 23.9      | 25.2 | 34.2 | MHz  | Note1       |               |
| Data                     | Setup Time    | $T_{dsu}$ | 8    | -    | -    | ns          | RL, GL, BL to |
|                          | Hold Time     | $T_{dhd}$ | 8    | -    | -    | ns          | DCLK          |
| DE                       | Setup Time    | $T_{esu}$ | 8    | -    | -    | ns          |               |
| Horizontal Section       | Period        | $T_H$     | 770  | 800  | 1000 | $T_{CLOCK}$ | Note1         |
|                          | Active        | $T_{HD}$  | 640  |      |      |             |               |
|                          | Blanking      | $T_{HB}$  | 130  | 160  | 360  |             |               |
| Vertical Section         | Period        | $T_V$     | 516  | 525  | 570  | $T_{LINE}$  | Note1         |
|                          | Active        | $T_{VD}$  | 480  |      |      |             |               |
|                          | Blanking      | $T_{VB}$  | 36   | 45   | 90   |             |               |

Note 1: Recommended frame rate is 60 Hz.

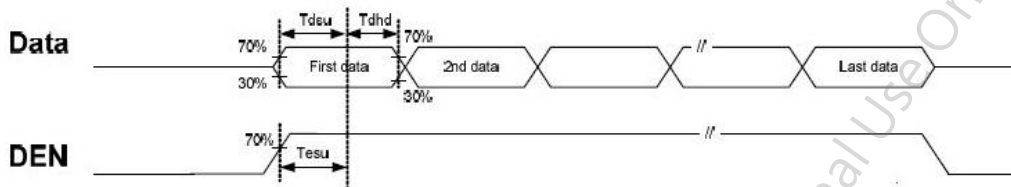

### 6.5.2 Input Timing Diagram

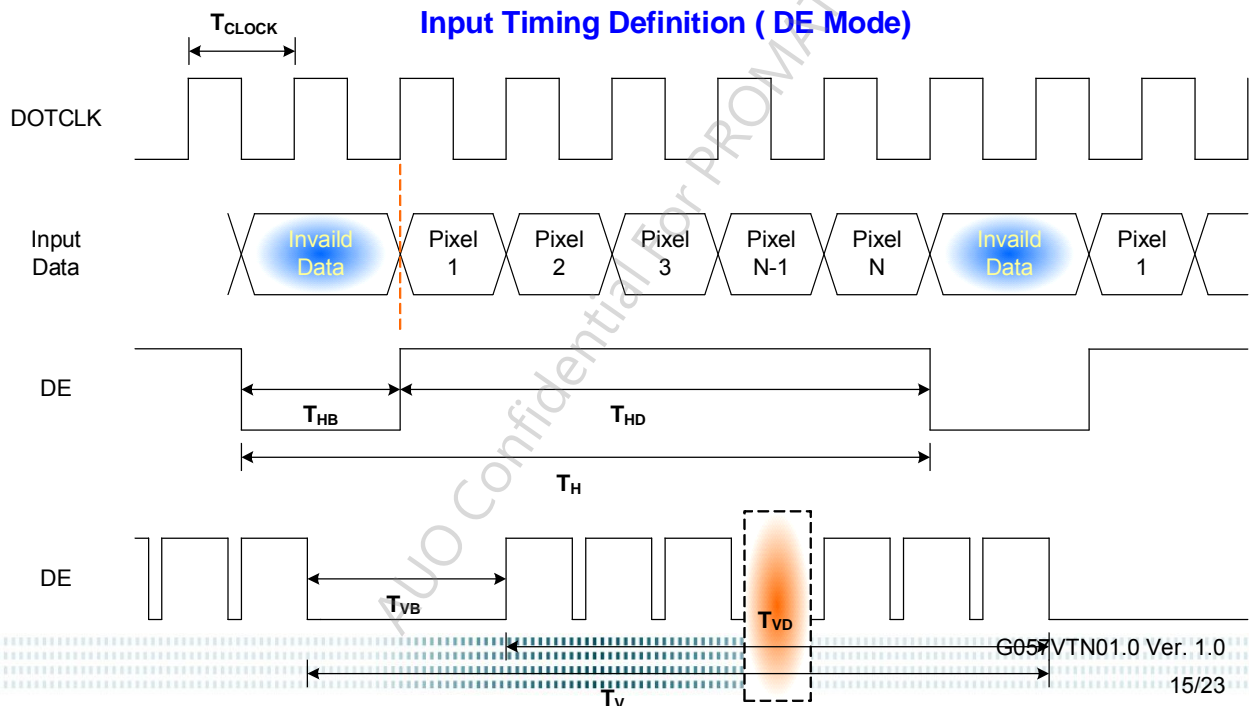

### 6.6 LED Backlight Unit Interface Signal Description

| Pin # | Symbol           | Pin Description      |
|-------|------------------|----------------------|
| 1     | V <sub>LED</sub> | 12V input            |
| 2     | V <sub>LED</sub> | 12V input            |
| 3     | GND              | Ground               |
| 4     | GND              | Ground               |
| 5     | PWM DIM          | 1~100% PWM dimming   |
| 6     | LED On/Off       | 0V-Off; 3.3~5V/NC-On |

Note 1: "NC" stands for "No Connection"

### 6.7 Power ON/OFF Sequence

VDD power, LCD interface signals and backlight on/off sequence are shown in the following chart. Signals from any system shall be Hi-Z state or low level when VDD is off.

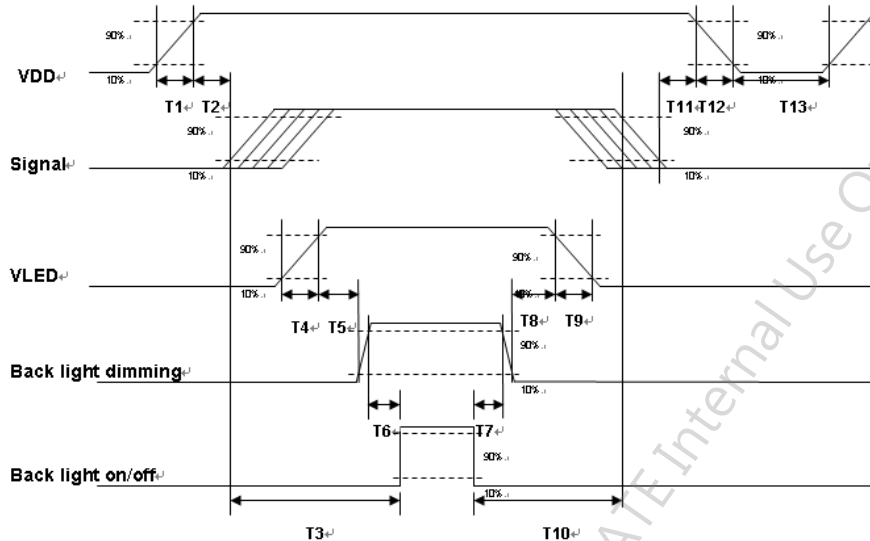

**Power ON/OFF sequence timing**

| Parameter | Value |      |      | Unit |
|-----------|-------|------|------|------|
|           | Min.  | Typ. | Max. |      |
| T1        | 0.5   | -    | 10   | [ms] |
| T2        | 30    | 40   | 50   | [ms] |
| T3        | 200   | -    | -    | [ms] |
| T4        | 0.5   | -    | 10   | [ms] |
| T5        | 10    | -    | -    | [ms] |
| T6        | 10    | -    | -    | [ms] |
| T7        | 0     | -    | -    | [ms] |
| T8        | 10    | -    | -    | [ms] |
| T9        | -     | -    | 10   | [ms] |
| T10       | 110   | -    | -    | [ms] |
| T11       | 0     | 18   | 50   | [ms] |
| T12       | -     | -    | 10   | [ms] |
| T13       | 1000  | -    | -    | [ms] |

ON/OFF sequence should be applied to avoid abnormal function in the display. Please make sure to turn off the power when you plug the cable into the input connector or pull the cable out of the connector.



## 7. Connector & Pin Assignment

### 7.1 TFT- LCD Signal (CN1): LCD Connector

|                               |                    |
|-------------------------------|--------------------|
| <b>Manufacturer</b>           | Starconn           |
| <b>Connector Model Number</b> | 089H33-000100-G2-R |

| Pin# | Symbol | Pin# | Symbol | Pin# | Symbol |
|------|--------|------|--------|------|--------|
| 1    | GND    | 12   | GND    | 23   | B3     |
| 2    | DOTCLK | 13   | G0     | 24   | B4     |
| 3    | NC     | 14   | G1     | 25   | B5     |
| 4    | NC     | 15   | G2     | 26   | GND    |
| 5    | GND    | 16   | G3     | 27   | DE     |
| 6    | R0     | 17   | G4     | 28   | VDD    |
| 7    | R1     | 18   | G5     | 29   | VDD    |
| 8    | R2     | 19   | GND    | 30   | R/L    |
| 9    | R3     | 20   | B0     | 31   | U/D    |
| 10   | R4     | 21   | B1     | 32   | NC     |
| 11   | R5     | 22   | B2     | 33   | GND    |

### 7.2 LED Backlight Unit (CN2): Backlight Connector

|                                      |                                  |
|--------------------------------------|----------------------------------|
| <b>Manufacturer</b>                  | JST                              |
| <b>Connector Model Number</b>        | SM06B-SRKS-G-TB (HF)             |
| <b>Mating Connector Model Number</b> | JST SHR-06V-BKHF-B or compatible |

| Pin # | Symbol           | Pin # | Symbol     |
|-------|------------------|-------|------------|
| 1     | V <sub>LED</sub> | 4     | GND        |
| 2     | V <sub>LED</sub> | 5     | PWM DIM    |
| 3     | GND              | 6     | LED ON/OFF |

### 7.3 LED Light Bar Input (CN3): Light Bar Connector

|                                      |                             |
|--------------------------------------|-----------------------------|
| <b>Manufacturer</b>                  | JST                         |
| <b>Connector Model Number</b>        | SM06B-SHLK-GTF(HF)          |
| <b>Mating Connector Model Number</b> | SM06B-SHLS-TF or compatible |

| Pin # | Symbol | Pin Description       | Cable color |
|-------|--------|-----------------------|-------------|
| 1     | AN1    | Channel 1 LED anode   | Red         |
| 2     | AN2    | Channel 2 LED anode   | Red         |
| 3     | AN3    | Channel 3 LED anode   | Red         |
| 4     | CA1    | Channel 1 LED cathode | White       |
| 5     | CA2    | Channel 2 LED cathode | Blue        |
| 6     | CA3    | Channel 3 LED cathode | Black       |

AUO Confidential For PROMATE Internal Use Only On 2015/01/09

## 7.4 PIN 1 definition of CN1、CN2 and CN3

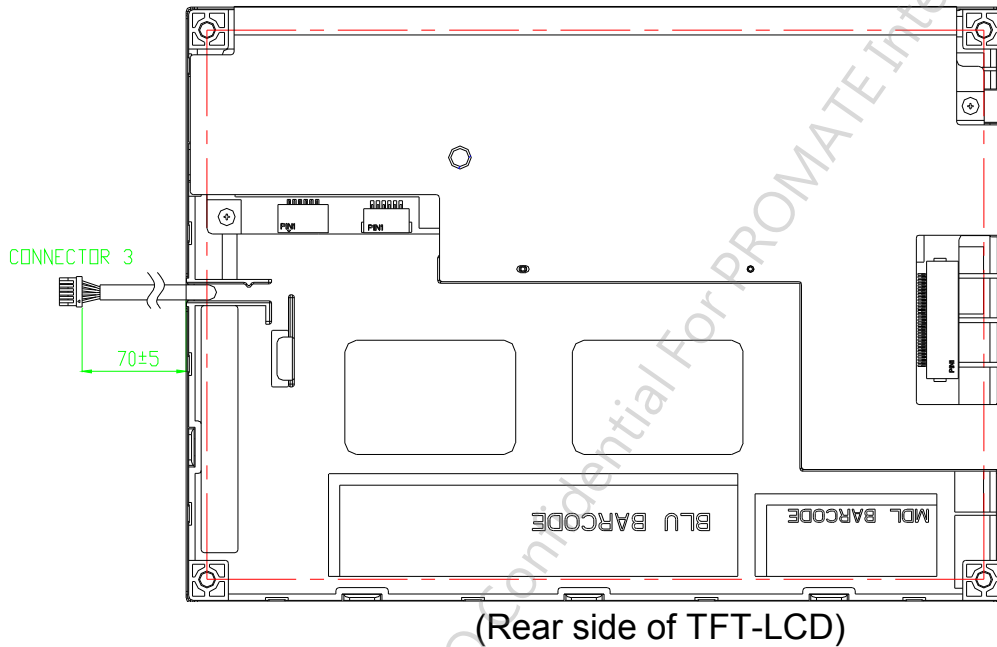
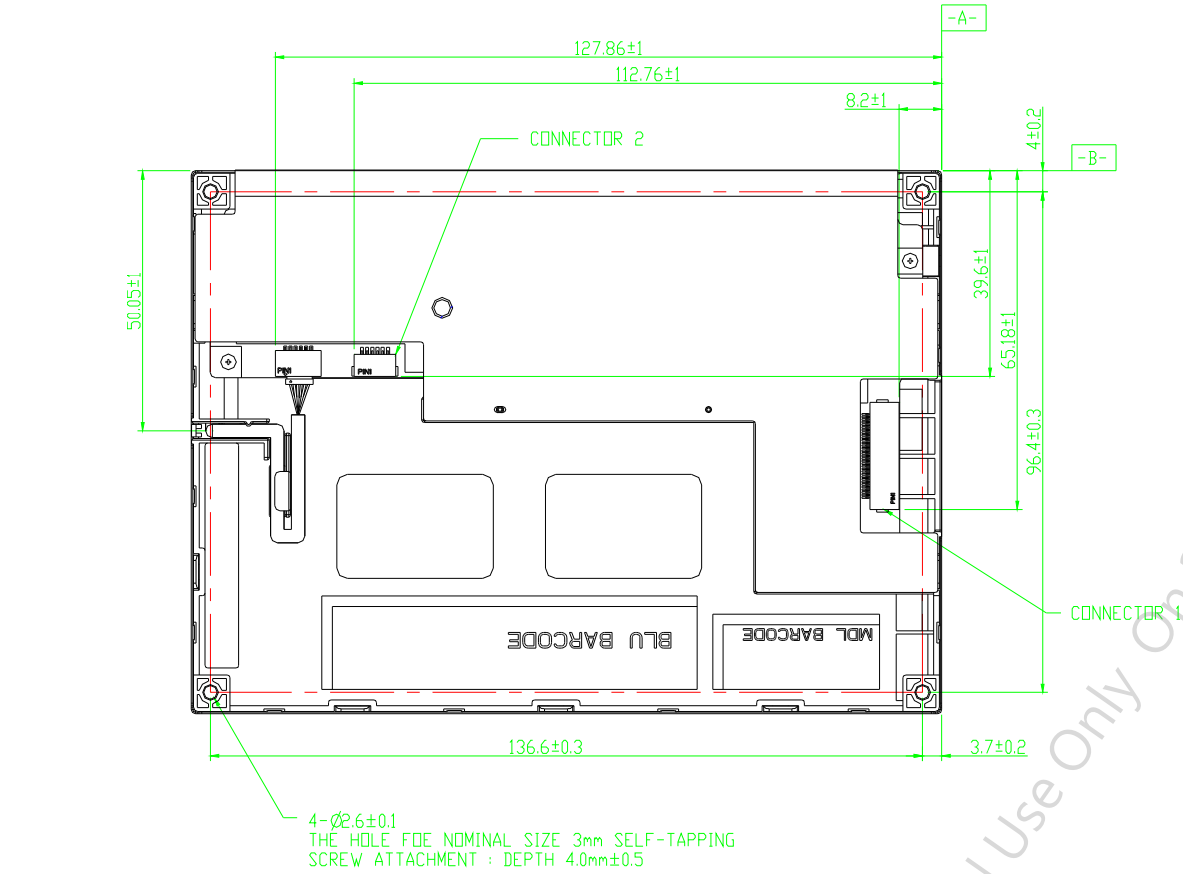

## 8. Reliability Test Criteria

| Items                             | Required Condition  | Remark   |
|-----------------------------------|---|----------|
| Temperature Humidity Bias         | 40 /90%,300Hr   | Note 2   |
| High Temperature Operation        | 85 ,300Hr   | Note 2   |
| Low Temperature Operation         | -30 ,300Hr  | Note 2   |
| High Temperature Storage          | 85 ,300 hours   | Note 2   |
| Low Temperature Storage           | -30 ,300 hours  | Note 2   |
| Thermal Shock Test                | -20 /30 min ,60 /30 min ,100cycles  | Note 2   |
| Hot Start Test                    | 85 /1 Hr (min.), power on/off per 5 minutes, repeat 5 times   | Note 2   |
| Cold Start Test                   | -30 /1 Hr (min.), power on/off per 5 minutes, repeat 5 times  | Note 2   |
| Shock Test<br>(Non-Operating)     | 50G,20ms,Half-sine wave, ( $\pm X$ , $\pm Y$ , $\pm Z$ )  | Note 2   |
| Vibration Test<br>(Non-Operating) | Sine wave : 6.8G , 10~400Hz , 280mins/axis , 0.6oct/min<br>Random : 3.3Grms , 5-500Hz , 30mins/axis   | Note 2   |
| ESD                               | Contact Discharge: $\pm 8KV$ , 150pF(330 $\Omega$ ) 1sec, 8 points, 25 times/point<br>Air Discharge: $\pm 15KV$ , 150pF(330 $\Omega$ ) 1sec, 8 points, 25 times/point | Note 1,2 |
| Attitude Test                     | Operating: 14,000 ft, Ramp: 2000 ft/min, 8hrs<br>Non-operating: 40,000 ft, Ramp: 2000 ft/min, 24hrs   | Note 2   |

Note1: According to EN61000-4-2 ESD class B criteria, some performance degradation is allowed. TFT-LCD module is self-recoverable, no data lost and no hardware failures after test.

Note2:

- Water condensation is not allowed for each test items.
- Each test is done by new TFT-LCD module. Don't use the same TFT-LCD module repeatedly for reliability test.
- The reliability test is performed only to examine the TFT-LCD module capability.
- To inspect TFT-LCD module after reliability test, please store it at room temperature and room humidity for 24 hours at least in advance.



G057VTN01.0

## 9. Mechanical Characteristics

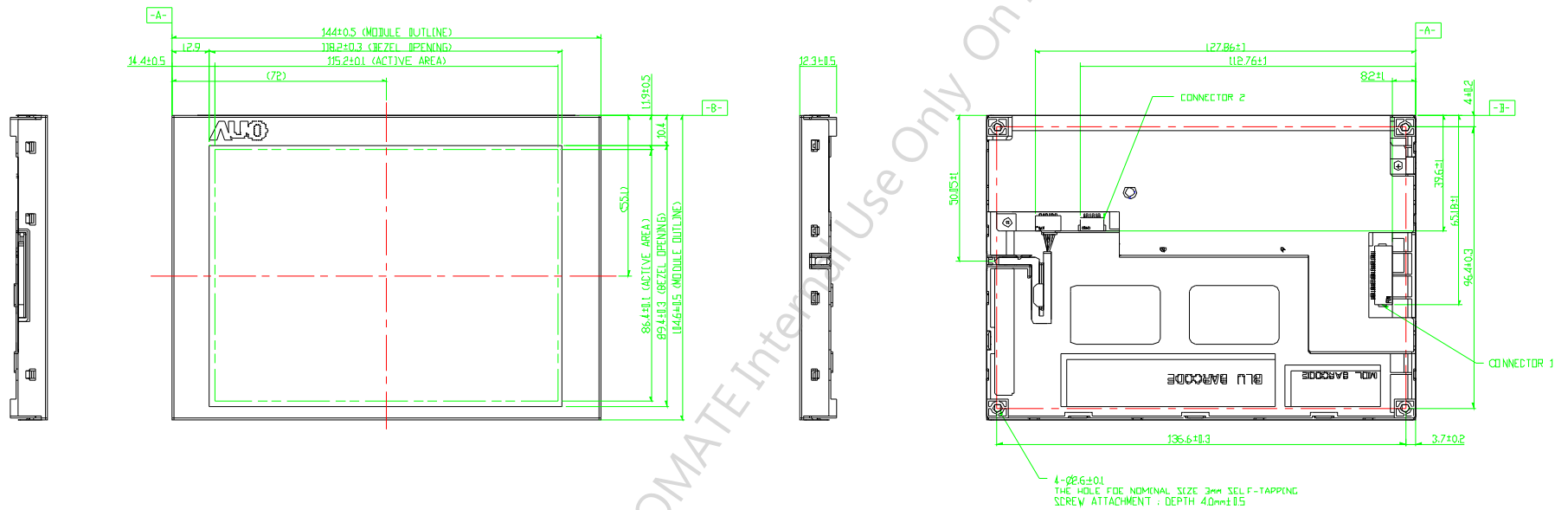

G057VTN01.0 Ver. 1.0

21/23

## 10. Label and Packaging

### 10.1 Shipping Label (on the rear side of TFT-LCD display)

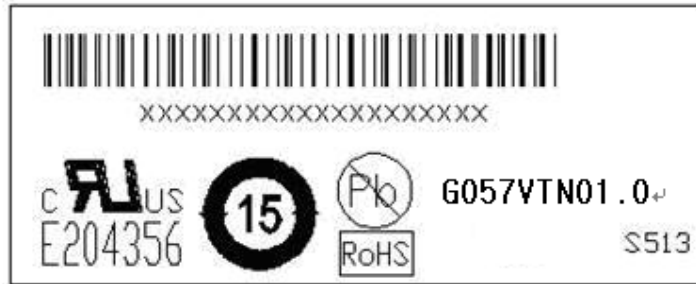

### 10.2 Carton Package

Max. capacity: 60 pieces TFT-LCD module per carton

Max. weight: 12.95 kg per carton

Outside dimension of carton: 520(L)mm\* 340(W)mm\* 250(H)mm

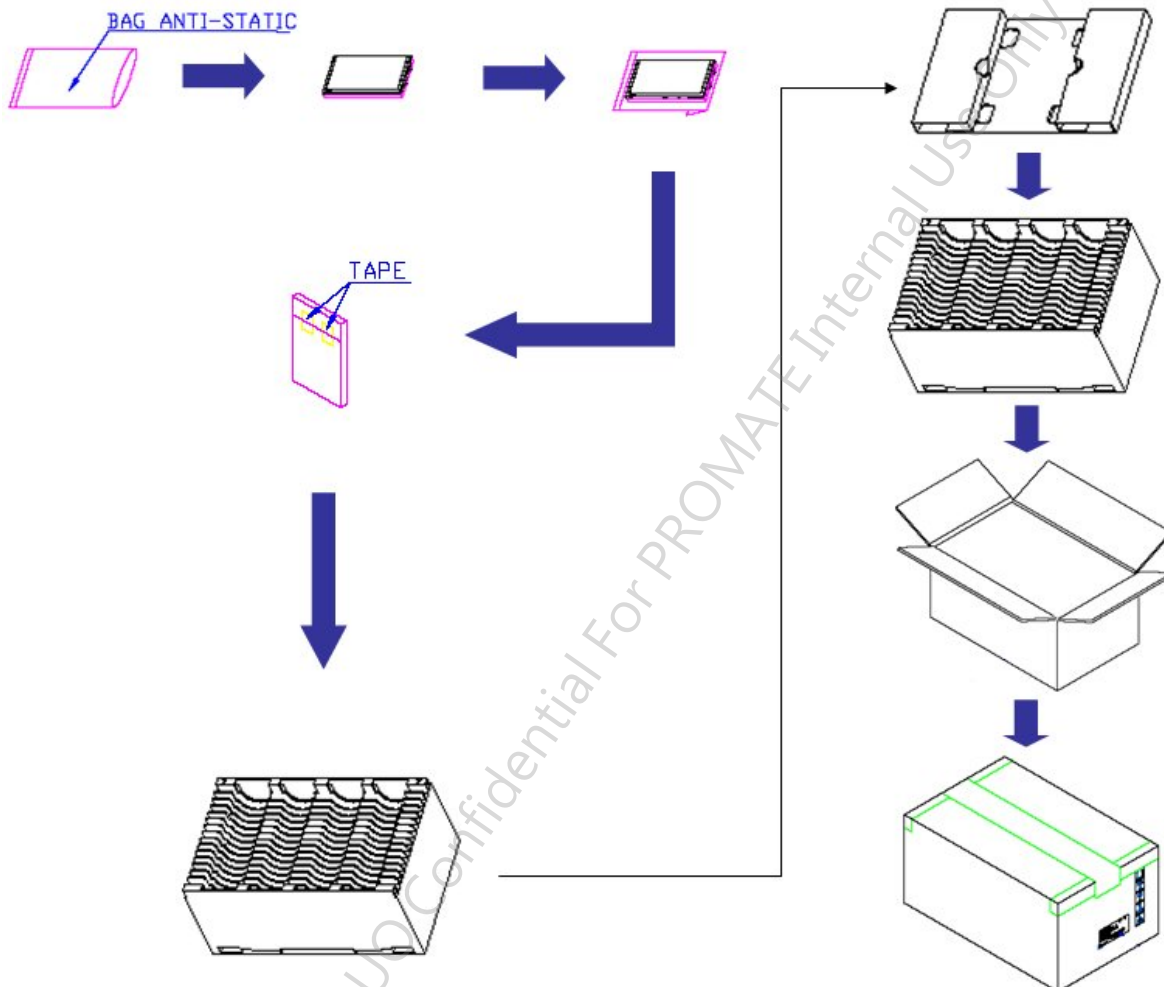

## 11 Safety

### 11.1 Keen Edge Requirements

There will be no keen edges or corners on the display assembly that could cause injury.

### 11.2 Materials

#### 11.2.1 Toxicity

There will be no carcinogenic materials used anywhere in the TFT-LCD module. If toxic materials are used, they will be reviewed and approved by the responsible AUO toxicologist.

#### 11.2.2 Flammability

All components including electrical components that do not meet the flammability grade UL94-V1 in the TFT-LCD Module will complete the flammability rating exception approval process.

The printed circuit board will be made from material rated 94-V1 or better. The actual UL flammability rating will be printed on the printed circuit board.

### 11.3 Capacitors

If any polarized capacitors are used in the TFT-LCD module, provisions will be made to keep them from being inserted backwards.

### 11.4 National Test Lab Requirement

The TFT-LCD Module will satisfy all requirements for compliance to UL 60950 (U.S.A. Information Technology Equipment).